

BEARINGS FOR THE CEMENT INDUSTRY

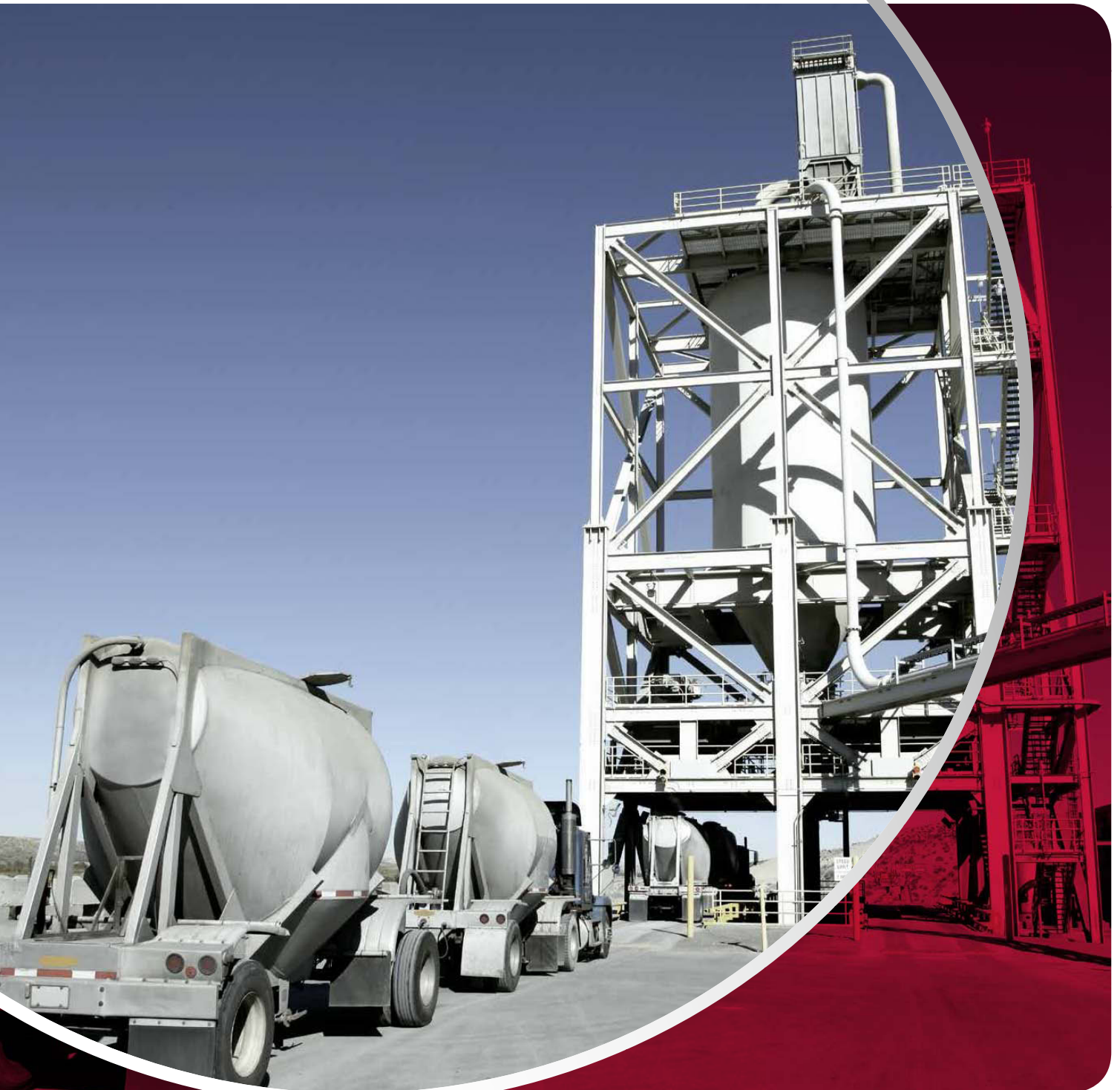

SUBSCRIBE TO NSK NEWSLETTER 

As one of the world's leading manufacturers of rolling bearings, linear technology components and steering systems, we can be found on almost every continent – with production facilities, sales offices and technology centres – because our customers appreciate short decision-making channels, prompt deliveries and local service.



The NSK company

NSK commenced operations as the first Japanese manufacturer of rolling bearings back in 1916. Ever since, we have been continuously expanding and improving not only our product portfolio but also our range of services for various industrial sectors. In this context, we develop technologies in the fields of rolling bearings, linear systems, components for the automotive industry and mechatronic systems. Our research and production facilities in Europe, Americas and Asia are linked together in a global technology network. Here

we concentrate not only on the development of new technologies, but also on the continuous optimisation of quality – at every process stage.

Among other things, our research activities include product design, simulation applications using a variety of analytical systems and the development of different steels and lubricants for rolling bearings.

Partnership based on trust – and trust based on quality

Total Quality by NSK: The synergies of our global network of NSK Technology Centres. Just one example of how we meet our requirements for high quality.

NSK is one of the leading companies with a long tradition in patent applications for machine parts. In our worldwide research centres, we not only concentrate on the development of new technologies, but also on the continual improvement of quality based on the integrated technology platform of

tribology, material technology, analysis and mechatronics.
More about NSK at www.nskeurope.com or call us on +44 (0)1636 605123



Cement Industry



Leaders in our field, we are not content simply to supply a range of products to meet the needs of today. At NSK we go much further: constantly challenging accepted thinking, exploring new and better methods of design and manufacture and, above all, looking beyond the needs of today to meet customers' requirements in the future.

Cement is one of the World's most important building materials – and its production one of the most severe processing environments, and so demands outstanding performance. NSK bearings provide the Cement and related industries with the reliability, sustainability and toughness required to withstand the critical processing factors of water, dust and grit, extreme temperatures, vibration and huge loads. Like other extreme processing and extraction industries, Cement machinery must continuously operate under these challenging conditions. NSK understands your production environments and maintenance issues, and that the solution to sustainable productivity lies in new technology.

As such our bearings are based on proprietary state-of-the-art technology, combined with the experience and knowledge from working with industry leaders. We have designed bearings to ensure your processes continue to run smoothly. NSK bearings exceed the limits of conventional bearings in terms of long operating life and high limiting speed to give you the toughness you require.

NSK Reliability helping you maintain your production momentum

NSK bearings offer the Cement industry plant operators and equipment manufacturers longer service life under some of the most challenging operating conditions. Maximising uptime and reducing maintenance costs for improved productivity at Cement plants. Durability and reliability are of paramount importance where failure of a single component can impact the entire Cement manufacturing process. Our superior bearings offer high performance with robust design, helping you improve profitability and productivity.

We continue to deliver the reliability required by Cement plants around the world.

Cement Industry Process

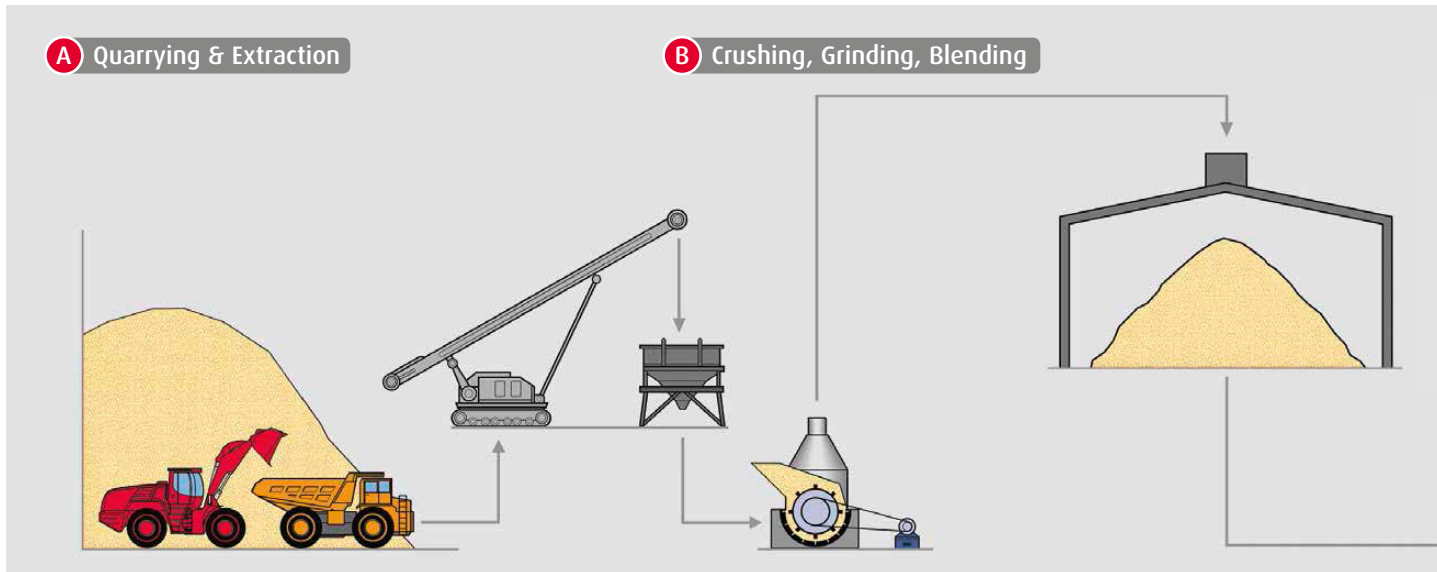

A Quarrying & Extraction

B Crushing, Grinding, Blending



Spherical Roller Bearings - EVB Series



Cylindrical Roller Bearings - EW and EM Series



Molded-Oil™ Bearings



Spherical Roller Bearings - HPS™ Series



Tapered Roller Bearings



Sealed Deep Groove Ball Bearings



Spherical Roller Bearings - CAM Series



Single Row Deep Groove Ball Bearings - HR Series



Self-Lube® Units



Long-life VS Spherical Roller Bearings



Angular Contact Ball Bearings - HPS™ Series



Mounted units



Angular Contact Ball Bearings - HPS™ Series



TF Series

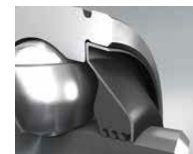

Triple Lip sealed



Sealed Deep Groove Ball Bearings



Needle Roller Bearings



Long-life Pinion Shaft with Cage & Roller Assembly

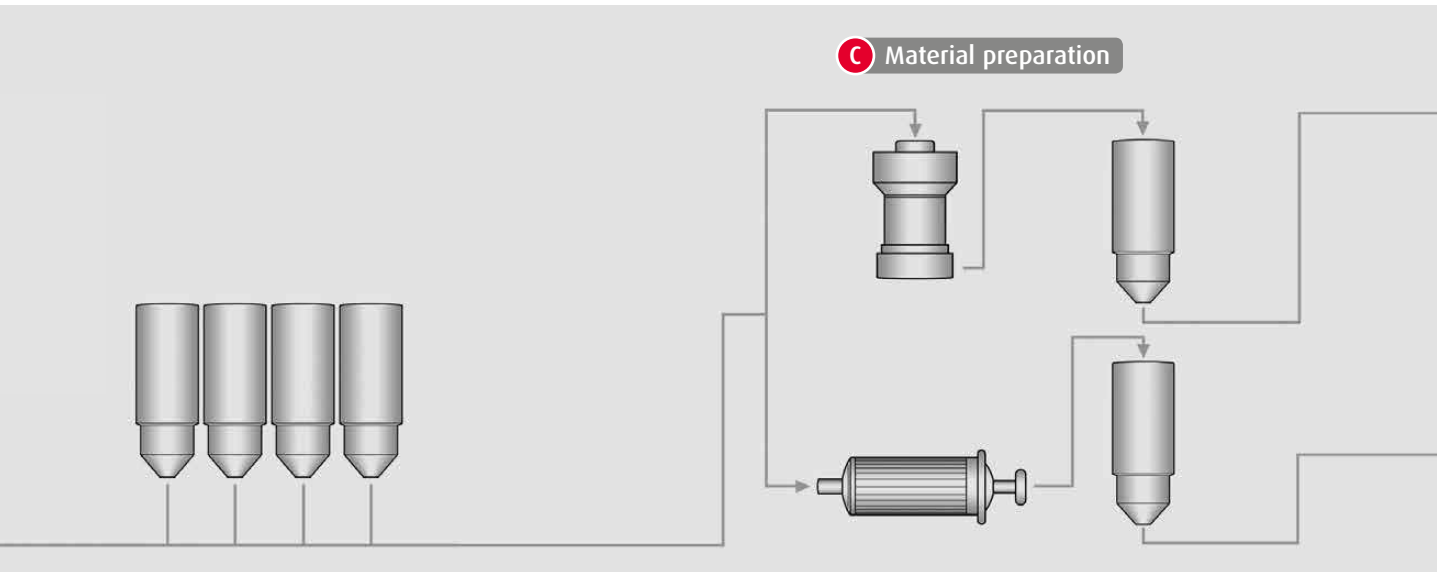

C Material preparation



Spherical Roller Bearings - HPS™ Series



Single Row Deep Groove Ball Bearings - HR Series



Spherical Roller Bearings - HPS™ Series



Long-life VS Spherical Roller Bearings



Double Row Angular Contact Ball Bearings



Cylindrical Roller Bearings - EW and EM Series



Integrated Bearing Assemblies



Cylindrical Roller Bearings - EW and EM Series



Tapered Roller Bearings



TF Series

D Pre-homogenisation

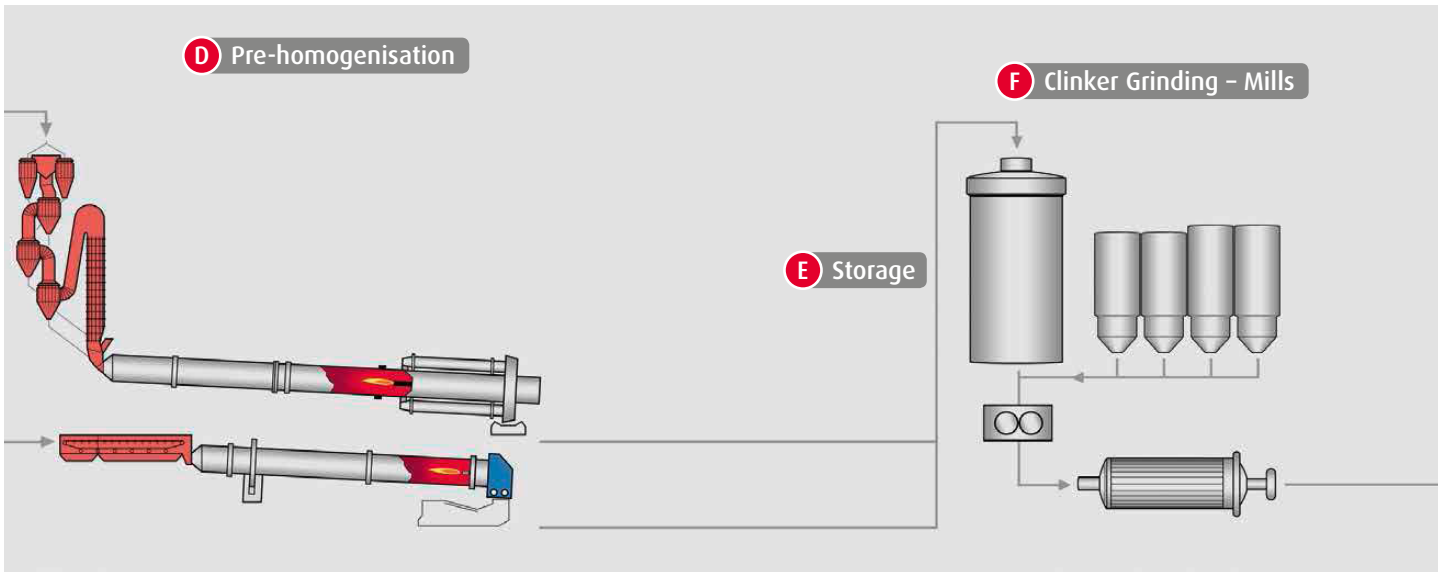

E Storage



Self-Lube® Units



Plummer Block Housings



Spherical Roller Bearings - HPS™ Series

F Clinker Grinding - Mills



Spherical Roller Bearings - HPS™ Series



Long-life VS Spherical Roller Bearings



Spherical Roller Bearings - CAM Series



Cylindrical Roller Bearings - EW and EM Series



Double-Row Tapered Roller Bearings



TF Series



Double Row Angular Contact Ball Bearings

G Conveying



Spherical Roller Bearings - HPS™ Series



Spherical Roller Bearings - CAM Series



G Conveying

H Packing & shipping

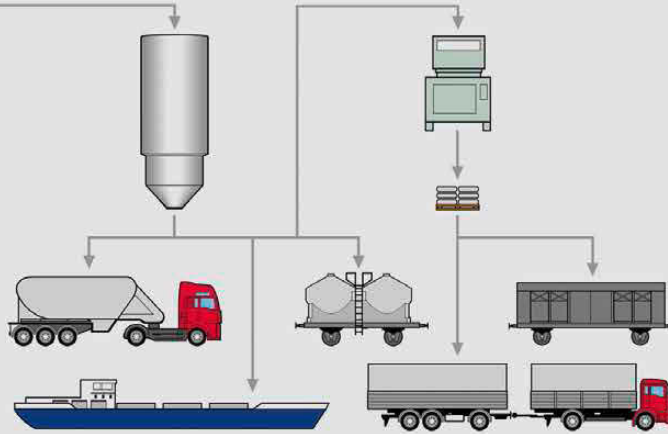

Self-Lube® Units



Tapered Roller Bearings



TF Series



Mounted units



TF Series



Sealed Deep Groove Ball Bearings



HLT Inserts



Self-Lube® Units



Single Row Deep Groove Ball Bearings - HR Series



HLT Inserts

H Packing & shipping



Angular Contact Ball Bearings - HPS™ Series



Spherical Roller Bearings - HPS™ Series



Mounted units



Cylindrical Roller Bearings - EW and EM Series



Molded-Oil™ Bearings

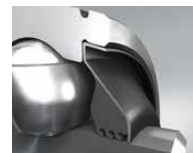

Triple Lip sealed

1. Features, Part Name, and Marking by Bearing Type



Spherical Roller Bearings – HPS™ Series

- › High load capacity
- › High limiting speed
- › High strength cage (steel or brass)
- › Low noise and vibration



Spherical Roller Bearings – CAM Series

- › Tough machined brass cage
- › Self-aligning ability with floating ring guide
- › Controlled roller skew
- › High dynamic and static load ratings
- › High speed performance – low operating temperature rise
- › High resistance to heavy & shock loading



Long-life VS Spherical Roller Bearings

- › Improved surface roughness on rollers, inner & outer ring
- › Specifically designed for Vibrating Screens
- › Load rating increased by 1.25 times
- › Dampened vibration
- › Better roller guidance & smooth running
- › Reduced bearing damage from slippage, surface fatigue, flaking



Spherical Roller Bearings – EVB Series

- › Extra capacity vibratory bearings
- › Heat stabilised up to 200°C
- › One-piece machined brass cage
- › Special ring tolerances to withstand vibration, shock loads & misalignment



Cylindrical Roller Bearings – EM Series

- › Extra capacity internal design
- › High strength brass cage – reduces wear and improves performance in vibrating equipment
- › Special cage pocket profiling improves oil / grease flow
- › 30% higher load rating than conventional bearings



Cylindrical Roller Bearings – EW Series

- › High radial load capacity
- › High speed applications
- › High strength pressed steel, machined brass or polyamide cage
- › Low noise & heat generation



Sealed Deep Groove Ball Bearings

- › Viton®* seals (black); Standard seals (brown)
- › High temperature Viton®* seals can run up to 200°C
- › Standard seals can run up to 120°C
- › Low noise level

* DuPont Performance Elastomers LLC



Single Row Deep Groove Ball Bearings – HR Series

- › Special internal design
- › Bigger rolling elements
- › Increased dynamic load rating
- › Increased life in operation
- › Interchangeable with the standard range
- › Extra clean Z steel as standard

Bearing Types



Self-Lube® Units

- › Range of diverse casting and pressed steel and thermoplastic housings
- › 3 main seal options – standard, triple lip, or flinger/standard
- › All cast housings supplied with re-greasing facility
- › Secure locking shaft for all speed, load and vibration conditions
- › Protector caps available



HLT inserts

- › Special internal geometry (cage & internal features) designed to operate at extreme temperatures
- › High performance Klüber grease operating at extreme temperatures (-40°C and +180°C)
- › Durable silicone rubber seals offer protection at extreme temperatures



Mounted Units

- › Sealed single-row ball bearing in a Pillow block or flanged housing
- › NSK units feature “flingers” that keep contaminants away
- › Housings available in ductile cast iron, cast steel or stainless steel
- › Variety of shaft locking mechanisms



Triple Lip Seal

- › Nitrile rubber triple lip seals
- › Longer life due to superior seal performance
- › Extended lubrication intervals – increases productivity of machines and reduces maintenance costs



Plummer Blocks

- › Split housing allows easy mounting and dis-mounting
- › Various sealing options available – V-ring seals, labyrinth or heavy duty taconite
- › Multi lubrication points



Integrated Bearing Assemblies

- › Bespoke Housings - High strength SG iron housing
- › Vibratory specification bearings:
50-60% vibration and noise reduction
- › Labyrinth & contact seals
- › Pre-greased & ready to fit – can be re-greased
- › Installation ease & benefits reduce in-house costs



Tapered Roller Bearings

- › Inch & metric sizes
- › Standard steel / carburised steel / HTF treatment
- › Custom-made sets with spacers



Double Row Taper Roller Bearings

- › Inch & metric sizes
- › Standard steel / carburised steel / HTF treatment
- › Also available with heavy-duty seals

Bearing Types



Molded-Oil™ Bearings

- › Grease-free property with no oil refilling
- › Operating life more than twice as long as grease lubrication (in water/dust contaminated environments)
- › Extended maintenance-free performance



TF Series

- › Innovative materials
- › Special heat treatment technology
- › Up to 10 times service life in contaminated lubrication
- › Up to 4 times service life at 160°C
- › 40% improvement on seizure resistance



Angular Contact Ball Bearings – HPS™ Series

- › Optimised internal design
- › High strength ball guided cage – available in brass, polyamide or L-PPS
- › High running accuracy P5 (ISO Class 5)
- › High load ratings
- › Universal facing as standard
- › 40 degree Contact Angle



Double Row Angular Contact Ball Bearings

- › High quality – Ultra clean steel
- › Steel or polyamide cage
- › Super finished raceways, minimises noise and improves lubricant distribution
- › Open or Shielded (ZZ or ZZ)
- › Sealed DDU or 2RS



Long-life Pinion shaft with cage & roller assembly

- › Compact & Lightweight
- › Special heat treatment to shaft & rollers
- › Mirror smooth finish on shaft & rollers ensures adequate oil film thickness
- › Reduces fatigue flaking and increased contamination resistance
- › Improves time between maintenance intervals



Needle Roller Bearings

- › Resin (Nylon 46) M type cage & roller assemblies
- › High durability even under heavy loads & misaligning operating conditions
- › Higher load capacity than conventional machined cages
- › Maintains inner cage strength at higher oil temperatures

Increasing efficiency – with AIP, the value-added programme from NSK

Incorrectly applied or selected bearings can lead to anything from a reduction in machine performance to failure of an entire system. We support you in solving these technical problems. The value-added programme AIP incorporates a comprehensive service package which enables you to design both productive operation and maintenance processes with increased efficiency and consequently better profitability. With AIP, you reduce your costs at every value-added stage.

Concentrated knowledge, many years of experience

Thanks to their in-depth technical knowledge and industry know-how, the experienced NSK application engineers are able to identify profitability potential and recommend appropriate measures. Our experts work according to a procedure which has been tested in practice and standardised – the value cycle. The ideally coordinated solution for your application is developed in close cooperation with them.

AIP services made to measure

The comprehensive range of AIP services is purposely designed to enhance efficiency and competitiveness. Your NSK expert will advise you about which measures can be derived from the examination results and will support you in implementing them. An app developed specially by NSK helps to collect data quickly on site and to perform calculations. Another app presents success stories from various branches of industry.



Cost Saver App

The cost savings calculator app enables potential cost savings to be calculated rapidly.



- › Stores Survey
- › Workshop Survey
- › Process Map
- › Bearing Cross Referencing



- › Application Reviews
- › Machine Design Support
- › OEM Part Conversion
- › Diagnostics



- › Product Training
- › Application of NSK Bearings
- › AIP Training
- › Industry Specific Training



- › Bearing Condition Analysis
- › Failed Bearing Analysis
- › Lubrication Analysis
- › Material & Dimensional Analysis

Discover how you can increase your profitability with the help of our value-added AIP programme and our high-quality products. **We will be pleased to send you our complete AIP brochure or contact you personally. Please email your enquiry to us at: aip@nsk.com**

Notes



A series of horizontal lines for writing notes, consisting of 20 evenly spaced lines.

NSK Sales Offices – Europe, Middle East and Africa

UK

NSK UK Ltd.
Northern Road, Newark
Nottinghamshire NG24 2JF
Tel. +44 (0) 1636 605123
Fax +44 (0) 1636 643276
info-uk@nsk.com

France & Benelux

NSK France S.A.S.
Quartier de l'Europe
2, rue Georges Guynemer
78283 Guyancourt Cedex
Tel. +33 (0) 1 30573939
Fax +33 (0) 1 30570001
info-fr@nsk.com

Germany, Austria, Switzerland, Nordic

NSK Deutschland GmbH
Harkortstraße 15
40880 Ratingen
Tel. +49 (0) 2102 4810
Fax +49 (0) 2102 4812290
info-de@nsk.com

Italy

NSK Italia S.p.A.
Via Garibaldi, 215
20024 Garbagnate
Milanese (MI)
Tel. +39 02 995 191
Fax +39 02 990 25 778
info-it@nsk.com

Middle East

NSK Bearings Gulf Trading Co.
JAFZA View 19, Floor 24 Office 2/3
Jebel Ali Downtown,
PO Box 262163
Dubai, UAE
Tel. +971 (0) 4 804 8205
Fax +971 (0) 4 884 7227
info-me@nsk.com

Poland & CEE

NSK Polska Sp. z o.o.
Warsaw Branch
Ul. Migdałowa 4/73
02-796 Warszawa
Tel. +48 22 645 15 25
Fax +48 22 645 15 29
info-pl@nsk.com

Russia

NSK Polska Sp. z o.o.
Russian Branch
Office 1 703, Bldg 29,
18th Line of Vasilievskiy Ostrov,
Saint-Petersburg, 199178
Tel. +7 812 3325071
Fax +7 812 3325072
info-ru@nsk.com

South Africa

NSK South Africa (Pty) Ltd.
25 Galaxy Avenue
Linbro Business Park
Sandton 2146
Tel. +27 (011) 458 3600
Fax +27 (011) 458 3608
nsk-sa@nsk.com

Spain

NSK Spain, S.A.
C/ Tarragona, 161 Cuerpo Bajo
2ª Planta, 08014 Barcelona
Tel. +34 93 2892763
Fax +34 93 4335776
info-es@nsk.com

Turkey

NSK Rulmanları Orta Doğu Tic. Ltd. Şti
19 Mayıs Mah. Atatürk Cad.
Ulya Engin İş Merkezi No: 68/3 Kat. 6
P.K.: 34736 - Kozyatağı - İstanbul
Tel. +90 216 4777111
Fax +90 216 4777174
turkey@nsk.com

Please also visit our website: www.nskeurope.com
Global NSK: www.nsk.com

