











# Rolling Bearings



<b>Technical Information</b>	<b>Pages</b> A7 ~A141	<b>Tech. Info.</b>
<b>Deep Groove Ball Brgs.</b>	B4 ~B45	
<b>Angular Contact Ball Brgs.</b>	B46 ~B71	
<b>Self-Aligning Ball Brgs.</b>	B72 ~B79	
<b>Cylindrical Roller Brgs.</b>	B80 ~B105	
<b>Tapered Roller Brgs.</b>	B106 ~B177	
<b>Spherical Roller Brgs.</b>	B178 ~B201	
<b>Thrust Brgs.</b>	B202 ~B239	Thrust Brgs.
<b>Needle Roller Brgs.</b>	B240 ~B275	
<b>Ball Brg. Units</b>	B276 ~B299	
<b>Plummer Blocks</b>	B300 ~B321	
<b>Cylindrical Roller Brgs. for Sheaves</b>	B322 ~B329	Sheaves
<b>Roll-Neck Brgs. (4-Rows) Railway Rolling Stock Brgs.</b>	B330 ~B341	Roll Neck Railway
<b>Balls and Rollers</b>	B342 ~B351	
<b>Accessories for Rolling Brgs.</b>	B352 ~B375	Sleeves 
<b>NSK Products and Appendices</b>	C1 ~C33	Appendices

---

# Rolling Bearings

---

CAT. No. E1102a

## **Introduction to Revised NSK Rolling Bearing Catalog (CAT.No.E1102a)**

We want to thank you for your interest in this edition of our Rolling Bearing Catalog. It has been revised with our customers in mind, and we hope it fills your needs.

Recently, technology has been advancing at a remarkable pace, and with it has come a host of new products in many fields including computers, office automation, audio-visual equipment, medical equipment, and many others. These striking innovations present a challenge to bearing manufacturers since there are ever increasing demand to offer bearings with higher performance, accuracy, and reliability. Manufacturers of diverse equipment have many different bearing requirements including higher speeds, less torque, less noise and vibration, zero maintenance, survival in harsh environments, integration into units, and many more.

This catalog was revised to reflect the growing number of NSK products and certain revisions in JIS and ISO and to better serve our customers. The first part contains general information about rolling bearings to facilitate selection of the most appropriate type. Next supplementary technical information is provided regarding bearing life, load ratings, limiting speeds, handling and mounting, lubrication, etc. Finally, the catalog presents extensive tables containing most bearing numbers and showing dimensions and pertinent design data listed in the order of increasing bore size. Data in the table are given in both the international Unit System (SI) and Engineering Unit System (Gravitational System of Units).

We hope this catalog will allow you to select the optimum bearing for your application. However, if assistance is required, please contact NSK, and the company's engineers and computer programs can quickly supply the information you need.



# 1. TYPES AND FEATURES OF ROLLING BEARINGS

## 1.1 Design and Classification

Rolling bearings generally consist of two rings, rolling elements, and a cage, and they are classified into radial bearings or thrust bearings depending on the direction of the main load. In addition, depending on the type of rolling elements, they are classified into ball bearings or roller bearings, and they are further segregated by differences in their design or specific purpose. The most common bearing types and nomenclature of bearing parts are shown in Fig.1.1, and a general classification of rolling bearings is shown in Fig. 1.2.

- (2) With the advancement of worldwide standardization, rolling bearings are internationally available and interchangeable.
- (3) Maintenance, replacement, and inspection are easy because the structure surrounding rolling bearings is simple.
- (4) Many rolling bearings are capable of taking both radial and axial loads simultaneously or independently.
- (5) Rolling bearings can be used under a wide range of temperatures.
- (6) Rolling bearings can be preloaded to produce a negative clearance and achieve greater rigidity.

## 1.2 Characteristics of Rolling Bearings

Compared with plain bearings, rolling bearings have the following major advantages:

- (1) Their starting torque or friction is low and the difference between the starting torque and running torque is small.

Furthermore, different types of rolling bearings have their own individual advantages. The features of the most common rolling bearings are described on Pages A10 to A12 and in Table 1.1 (Pages A14 and A15).

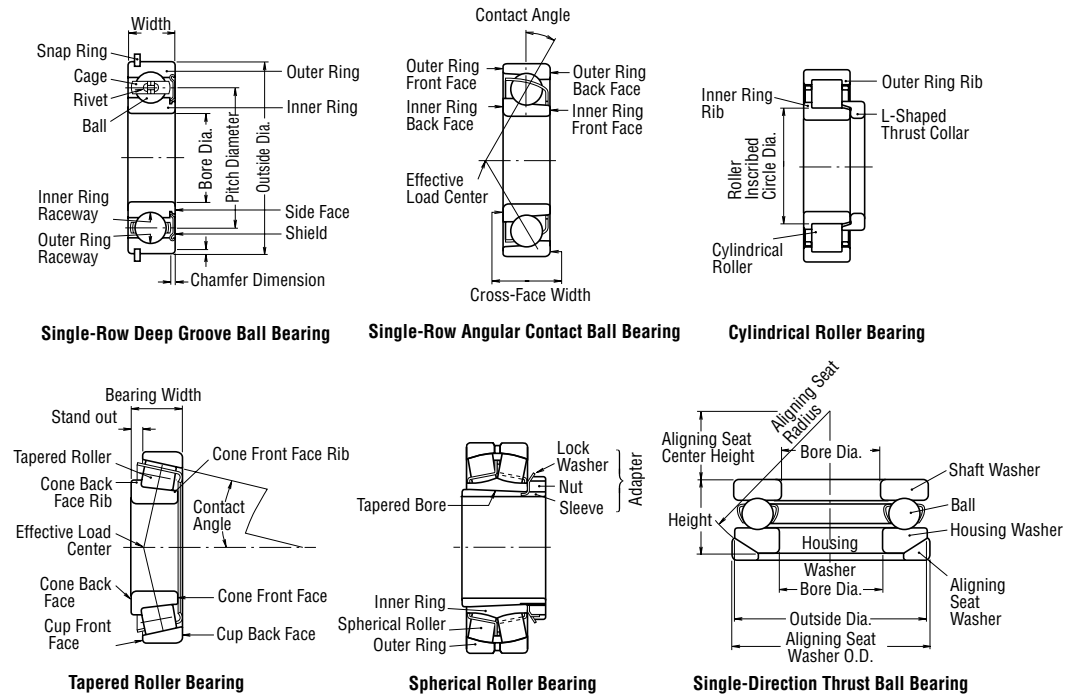

Fig. 1.1 Nomenclature for Bearing Parts

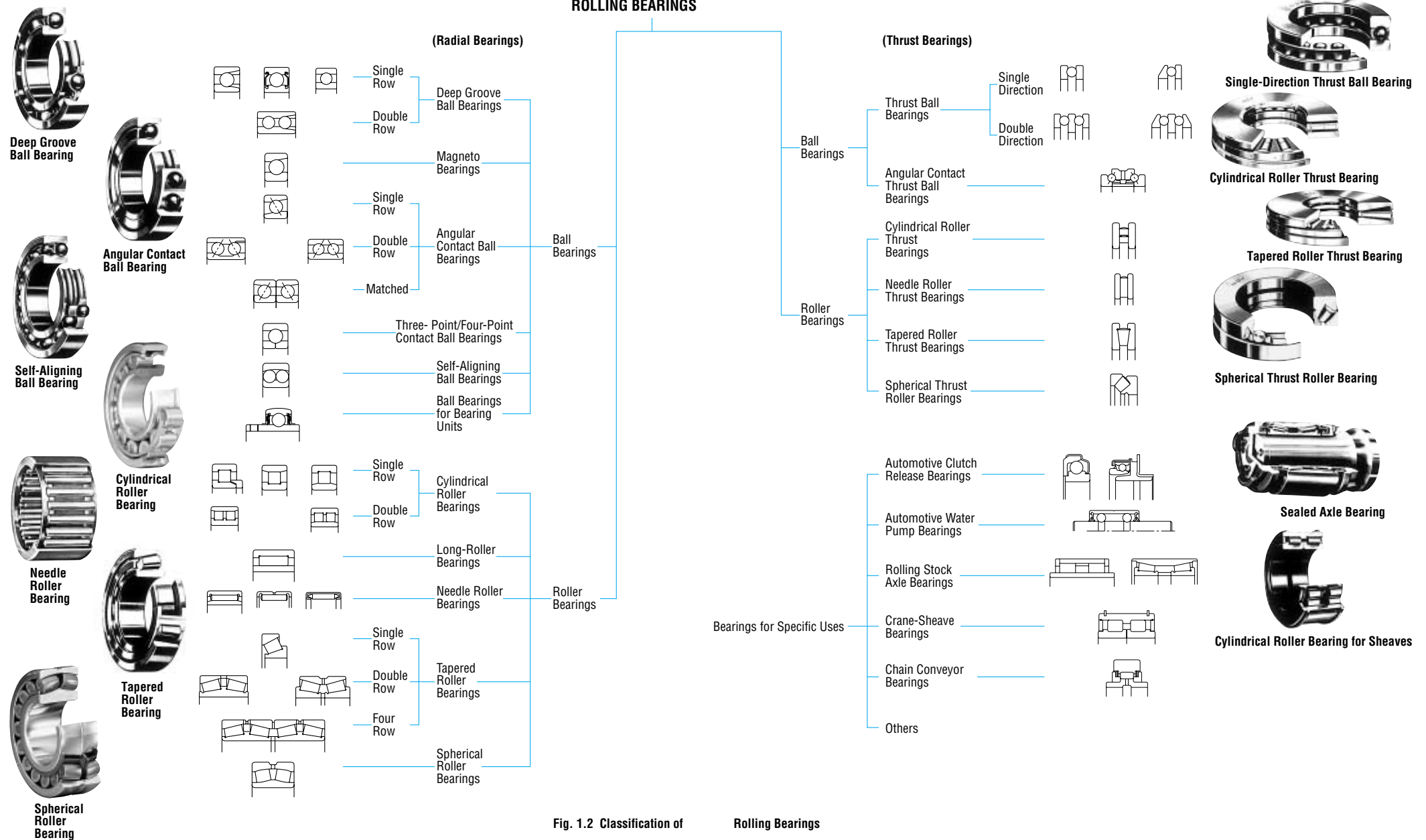
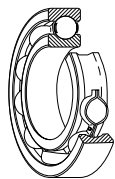

Fig. 1.2 Classification of Rolling Bearings

**Single-Row Deep Groove Ball Bearings**

Single-row deep groove ball bearings are the most common type of rolling bearings. Their use is very widespread. The raceway grooves on both the inner and outer rings have circular arcs of slightly larger radius than that of the balls. In addition to radial loads, axial loads can be imposed in either direction. Because of their low torque, they are highly suitable for applications where high speeds and low power loss are required. In addition to open type bearings, these bearings often have steel shields or rubber seals installed on one or both sides and are prelubricated with grease. Also, snap rings are sometimes used on the periphery. As to cages, pressed steel ones are the most common.



**Magneto Bearings**

The inner groove of magneto bearings is a little shallower than that of deep groove bearings. Since the outer ring has a shoulder on only one side, the outer ring may be removed. This is often advantageous for mounting. In general, two such bearings are used in duplex pairs. Magneto bearings are small bearings with a bore diameter of 4 to 20 mm and are mainly used for small magnetos, gyroscopes, instruments, etc. Pressed brass cages are generally used.

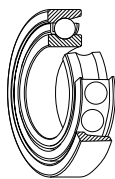

**Single-Row Angular Contact Ball Bearings**

Individual bearings of this type are capable of taking radial loads and also axial loads in one direction. Four contact angles of 15°, 25°, 30°, and 40° are available. The larger the contact angle, the higher the axial load capacity. For high speed operation, however, the smaller contact angles are preferred. Usually, two bearings are used in duplex pairs, and the clearance between them must be adjusted properly. Pressed-steel cages are commonly used, however, for high precision bearings with a contact angle less than 30°, polyamide resin cages are often used.

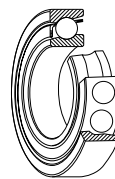

**Duplex Bearings**

A combination of two radial bearings is called a duplex pair. Usually, they are formed using angular contact ball bearings or tapered roller bearings. Possible combinations include face-to-face, which have the outer ring faces together (type DF), back-to-back (type DB), or both front faces in the same direction (type DT). DF and DB duplex bearings are capable of taking radial loads and axial loads in either direction. Type DT is used when there is a strong axial load in one direction and it is necessary to impose the load equally on each bearing.

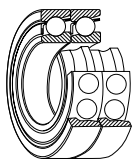

**Double-Row Angular Contact Ball Bearings**

Double-row angular contact ball bearings are basically two single-row angular contact ball bearings mounted back-to-back except that they have only one inner ring and one outer ring, each having raceways. They can take axial loads in either direction.

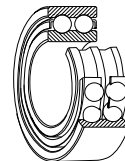

**Four-Point Contact Ball Bearings**

The inner and outer rings of four-point contact ball bearings are separable because the inner ring is split in a radial plane. They can take axial loads from either direction. The balls have a contact angle of 35° with each ring. Just one bearing of this type can replace a combination of face-to-face or back-to-back angular contact bearings. Machined brass cages are generally used.

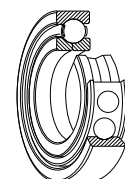

**Self-Aligning Ball Bearings**

The inner ring of this type of bearing has two raceways and the outer ring has a single spherical raceway with its center of curvature coincident with the bearing axis. Therefore, the axis of the inner ring, balls, and cage can deflect to some extent around the bearing center. Consequently, minor angular misalignment of the shaft and housing caused by machining or mounting error is automatically corrected. This type of bearing often has a tapered bore for mounting using an adapter sleeve.

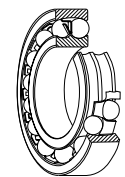

**Cylindrical Roller Bearings**

In bearings of this type, the cylindrical rollers are in linear contact with the raceways. They have a high radial load capacity and are suitable for high speeds. There are different types designated NU, NJ, NUP, N, NF for single-row bearings, and NNU, NN for double-row bearings depending on the design or absence of side ribs. The outer and inner rings of all types are separable. Some cylindrical roller bearings have no ribs on either the inner or outer ring, so the rings can move axially relative to each other. These can be used as free-end bearings. Cylindrical roller bearings, in which either the inner or outer rings has two ribs and the other ring has one, are capable of taking some axial load in one direction. Double-row cylindrical roller bearings have high radial rigidity and are used primarily for precision machine tools. Pressed steel or machined brass cages are generally used, but sometimes molded polyamide cages are also used.

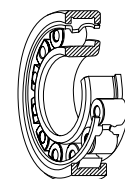



**Needle Roller Bearings**

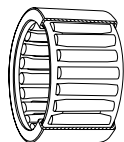

Needle roller bearings contain many slender rollers with a length 3 to 10 times their diameter. As a result, the ratio of the bearing outside diameter to the inscribed circle diameter is small, and they have a rather high radial load capacity. There are numerous types available, and many have no inner rings. The drawn-cup type has a pressed steel outer ring and the solid type has a machined outer ring. There are also cage and roller assemblies without rings. Most bearings have pressed steel cages, but some are without cages.

**Tapered Roller Bearings**

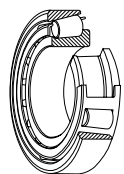

Bearings of this type use conical rollers guided by a back-face rib on the cone. These bearings are capable of taking high radial loads and also axial loads in one direction. In the HR series, the rollers are increased in both size and number giving it an even higher load capacity. They are generally mounted in pairs in a manner similar to single-row angular contact ball bearings. In this case, the proper internal clearance can be obtained by adjusting the axial distance between the cones or cups of the two opposed bearings. Since they are separable, the cone assemblies and cups can be mounted independently. Depending upon the contact angle, tapered roller bearings are divided into three types called the normal angle, medium angle, and steep angle. Double-row and four-row tapered roller bearings are also available. Pressed steel cages are generally used.

**Spherical Roller Bearings**

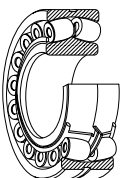

These bearings have barrel-shaped rollers between the inner ring, which has two raceways, and the outer ring which has one spherical raceway. Since the center of curvature of the outer ring raceway surface coincides with the bearing axis, they are self-aligning in a manner similar to that of self-aligning ball bearings. Therefore, if there is deflection of the shaft or housing or misalignment of their axes, it is automatically corrected so excessive force is not applied to the bearings. Spherical roller bearings can take, not only heavy radial loads, but also some axial loads in either direction. They have excellent radial load-carrying capacity and are suitable for use where there are heavy or impact loads. Some bearings have tapered bores and may be mounted directly on tapered shafts or cylindrical shafts using adapters or withdrawal sleeves. Pressed steel and machined brass cages are used.

**Single-Direction Thrust Ball Bearings**



Single-direction thrust ball bearings are composed of washer-like bearing rings with raceway grooves. The ring attached to the shaft is called the shaft washer (or inner ring) while that attached to the housing is called the housing washer (or outer ring).

**Double-Direction Thrust Ball Bearings**

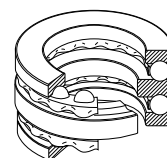

In double-direction thrust ball bearings, there are three rings with the middle one (center ring) being fixed to the shaft. There are also thrust ball bearings with an aligning seat washer beneath the housing washer in order to compensate for shaft misalignment or mounting error. Pressed steel cages are usually used in the smaller bearings and machined cages in the larger

**Spherical Thrust Roller Bearings**



These bearings have a spherical raceway in the housing washer and barrel-shaped rollers obliquely arranged around it. Since the raceway in the housing washer is spherical, these bearings are self-aligning. They have a very high axial load capacity and are capable of taking moderate radial loads when an axial load is applied. Pressed steel cages or machined brass cages are usually used.

Table 1. 1 Types and Characteristics

Features		Deep Groove Ball Bearings	Magneto Bearings	Angular Contact Ball Bearings	Double-Row Angular Contact Ball Bearings	Duplex Angular Contact Ball Bearings	Four-Point Contact Ball Bearings	Self-Aligning Ball Bearings	Cylindrical Roller Bearings	Double-Row Cylindrical Roller Bearings	Cylindrical Roller Bearings with Single Rib
Load Capacity	Radial Loads										
	Axial Loads										
	Combined Loads										
High Speeds											
High Accuracy											
Low Noise and Torque											
Rigidity											
Angular Misalignment											
Self-Aligning Capability											
Ring Separability											
Fixed-End Bearing											
Free-End Bearing											
Tapered Bore in Inner Ring											
Remarks			Two bearings are usually mounted in opposition.	Contact angles of 15°, 25°, 30°, and 40°. Two bearings are usually mounted in opposition. Clearance adjustment is necessary.		Combination of DF and DT pairs is possible, but use on free-end is not possible.	Contact angle of 35°		Including N type	Including NNU type	Including NF type
Page No.		B5 B31	B5 B28	B47	B47 B66	B47	B47 B68	B73	B81	B81 B106	B81

Excellent   
 Good   
 Fair   
 Poor   
 Impossible   
 One direction only   
 Two directions  
 ☆ Applicable    ★ Applicable, but it is necessary to allow shaft contraction/elongation at fitting surfaces of bearings.

of Rolling Bearings

Cylindrical Roller Bearings with Thrust Collars	Needle Roller Bearings	Tapered Roller Bearings	Double- and Multiple-Row Tapered Roller Bearings	Spherical Roller Bearings	Thrust Ball Bearings	Thrust Ball Bearings with Aligning Seat	Double-Direction Angular Contact Thrust Ball Bearings	Cylindrical Roller Thrust Bearings	Tapered Roller Thrust Bearings	Spherical Thrust Roller Bearings	Page No.
											—
											—
											—
											—
											A18 A37
											A19 A58 A81
											A19
											A19 A96
											A18 Blue pages of each brg. type
											A18
											A19 A20
											A20 ~A21
											A20 ~A27
											A80 A118 A122
Including NUP type			Two bearings are usually mounted in opposition. Clearance adjustment is necessary.								
Including NNU type			KH, KV types are also available but use on free-end is impossible.								
Including NF type											
Including needle roller thrust bearings											
To be used with oil lubrication											
B81	—	B111	B111 B172 B295	B179	B203	B203	B231	B203 B220	—	B203 B224	

## 2. BEARING SELECTION PROCEDURE

The number of applications for rolling bearings is almost countless and the operating conditions and environments also vary greatly. In addition, the diversity of operating conditions and bearing requirements continue to grow with the rapid advancement of technology. Therefore, it is necessary to study bearings carefully from many angles to select the best one from the thousands of types and sizes available.

Usually, a bearing type is provisionally chosen considering the operating conditions, mounting arrangement, ease of mounting in the machine, allowable space, cost, availability, and other factors.

Then the size of the bearing is chosen to satisfy the desired life requirement. When doing this, in addition to fatigue life, it is necessary to consider grease life, noise and vibration, wear, and other factors.

There is no fixed procedure for selecting bearings. It is good to investigate experience with similar applications and studies relevant to any special requirements for your specific application. When selecting bearings for new machines, unusual operating conditions, or harsh environments, please consult with NSK.

The following diagram (Fig.2.1) shows an example of the bearing selection procedure.

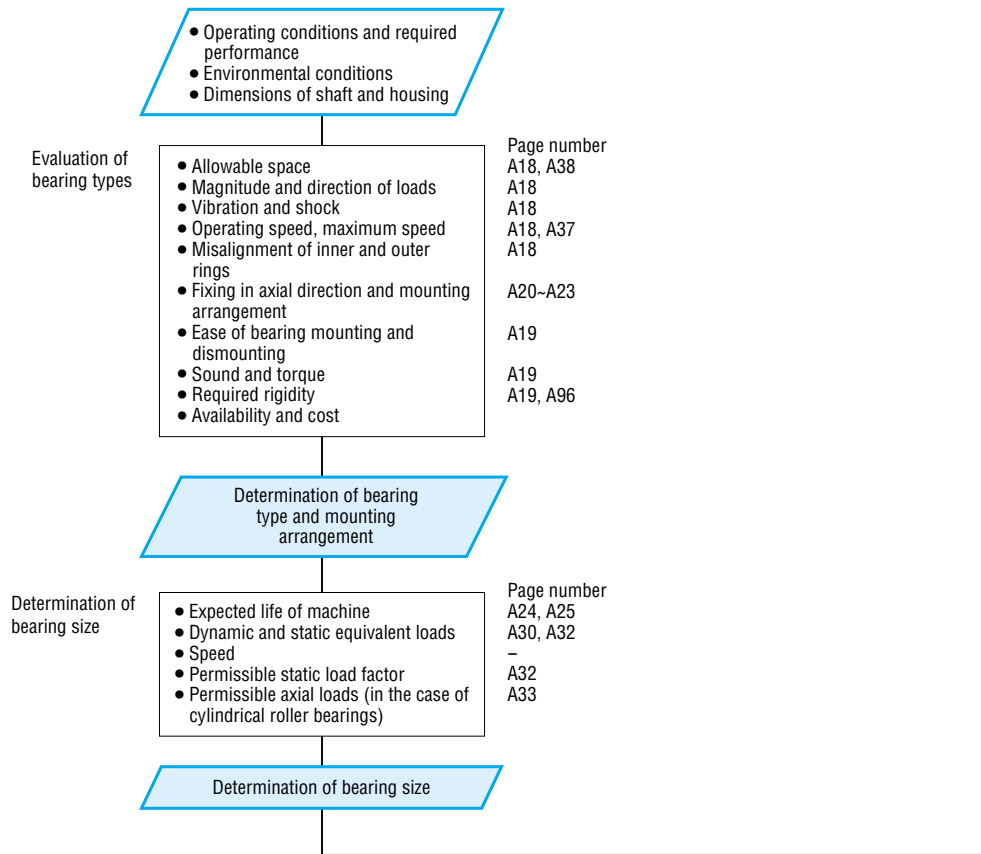
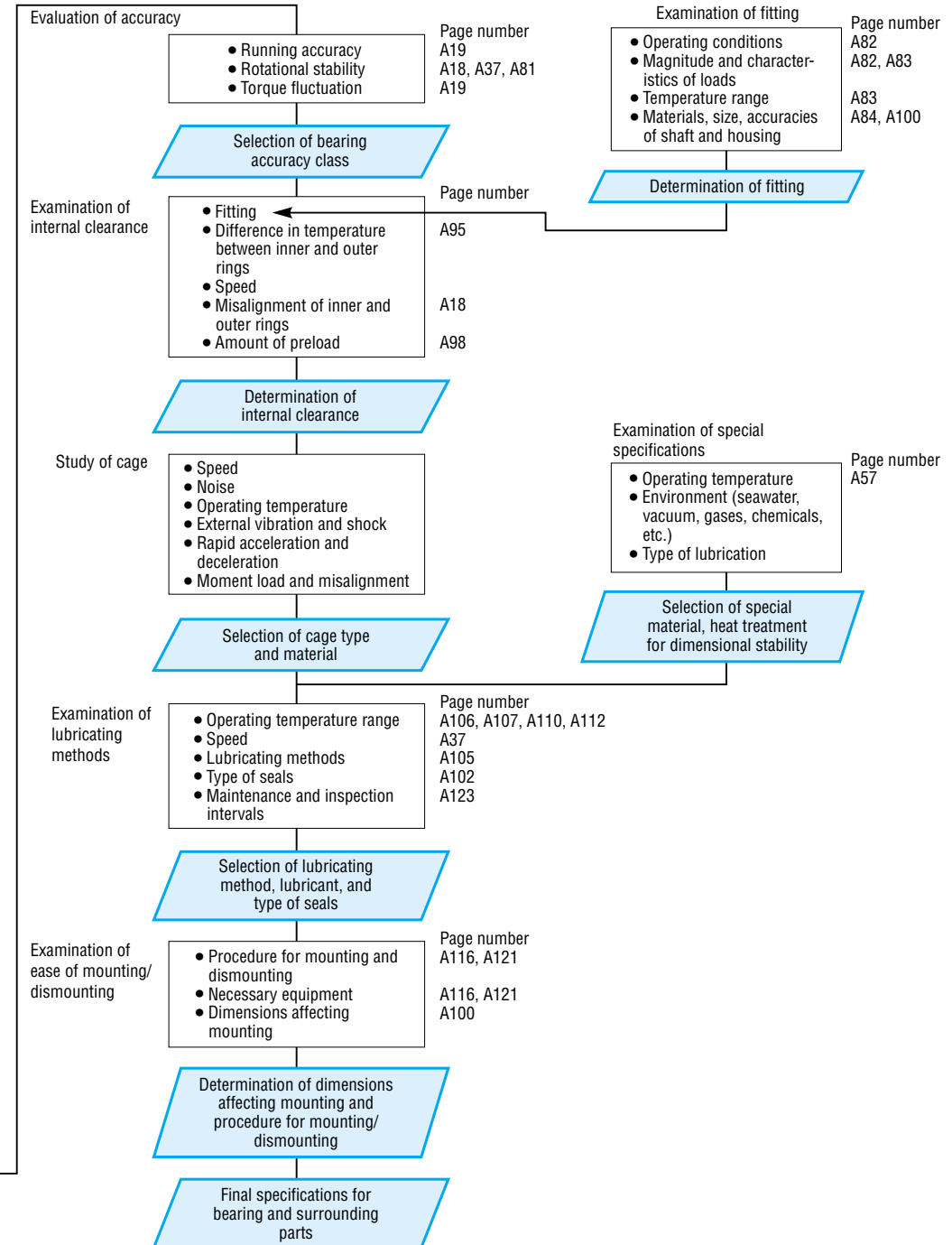

Fig. 2.1 Flow Chart for Selection of Rolling Bearings



### 3. SELECTION OF BEARING TYPES

#### 3.1 Allowable Bearing Space

The allowable space for a rolling bearing and its adjacent parts is generally limited so the type and size of the bearing must be selected within such limits. In most cases, the shaft diameter is fixed first by the machine design; therefore, the bearing is often selected based on its bore size. For rolling bearings, there are numerous standardized dimension series and types, and the selection of the optimum bearing from among them is necessary. Fig. 3.1 shows the dimension series of radial bearings and corresponding bearing types.

#### 3.2 Load Capacity and Bearing Types

The axial load carrying capacity of a bearing is closely related to the radial load capacity (see Page A24) in a manner that depends on the bearing design as shown in Fig. 3.2. This figure makes it clear that when bearings of the same dimension series are compared, roller bearings have a higher load capacity than ball bearings and are superior if shock loads exist.

#### 3.3 Permissible Speed and Bearing Types

The maximum speed of rolling bearings varies depending, not only the type of bearing, but also its size, type of cage, loads, lubricating method, heat dissipation, etc. Assuming the common oil bath lubrication method, the bearing types are roughly ranked from higher speed to lower as shown in Fig. 3.3.

#### 3.4 Misalignment of Inner/Outer Rings and Bearing Types

Because of deflection of a shaft caused by applied loads, dimensional error of the shaft and housing, and mounting errors, the inner and outer rings are slightly misaligned. The permissible misalignment varies depending on the bearing type and operating conditions, but usually it is a small angle less than 0.0012 radian (4'). When a large misalignment is expected, bearings having a self-aligning capability, such as self-aligning ball bearings, spherical roller bearings, and certain bearing units should be selected (Figs. 3.4 and 3.5).

Permissible bearing misalignment is given at the beginning of the dimensional tables for each bearing type.

#### 3.5 Rigidity and Bearing Types

When loads are imposed on a rolling bearing, some elastic deformation occurs in the contact areas between the rolling elements and raceways. The rigidity of the bearing is determined by the ratio of bearing load to the amount of elastic deformation of the inner and outer rings and rolling elements. For the main spindles of machine tools, it is necessary to have high rigidity of the bearings together with the rest of the spindle. Consequently, since roller bearings are deformed less by load, they are more often selected than ball bearings. When extra high rigidity is required, bearings are given a preload, which means that they have a negative clearance. Angular contact ball bearings and tapered roller bearings are often preloaded.

#### 3.6 Noise and Torque of Various Bearing Types

Since rolling bearings are manufactured with very high precision, noise and torque are minimal. For deep groove ball bearings and cylindrical roller bearings particularly, the noise level is sometimes specified depending on their purpose. For high precision miniature ball bearings, the starting torque is specified. Deep groove ball bearings are recommended for applications in which low noise and torque are required, such as motors and instruments.

#### 3.7 Running Accuracy and Bearing Types

For the main spindles of machine tools that require high running accuracy or high speed applications like superchargers, high precision bearings of Class 5, 4 or 2 are usually used. The running accuracy of rolling bearings is specified in various ways, and the specified accuracy classes vary depending on the bearing type. A comparison of the inner ring radial runout for the highest running accuracy specified for each bearing type is shown in Fig. 3.6.

For applications requiring high running accuracy, deep groove ball bearings, angular contact ball bearings, and cylindrical roller bearings are most suitable.

#### 3.8 Mounting and Dismounting of Various Bearing Types

Separable types of bearings like cylindrical roller bearings, needle roller bearings and tapered roller bearings are convenient for mounting and dismounting. For machines in which bearings are mounted and dismounted rather often for periodic inspection, these types of bearings are recommended. Also, self-aligning ball bearings and spherical roller bearings (small ones) with tapered bores can be mounted and dismounted relatively easily using sleeves.

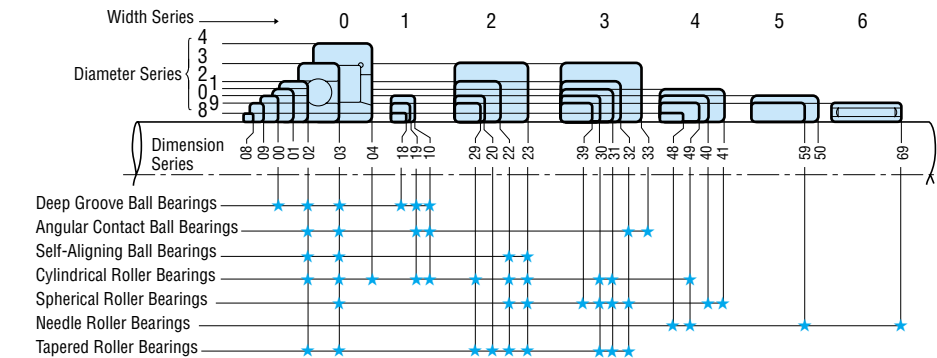

Fig. 3.1 Dimension Series of Radial Bearings

Bearing Type	Radial load capacity				Axial load capacity			
	1	2	3	4	1	2	3	4
Single-Row Deep Groove Ball Bearings	1	2	3	4	1	2	3	4
Single-Row Angular Contact Ball Bearings	1	2	3	4	1	2	3	4
Cylindrical Roller(*) Bearings	1	2	3	4	1	2	3	4
Tapered Roller Bearings	1	2	3	4	1	2	3	4
Spherical Roller Bearings	1	2	3	4	1	2	3	4

Note(\*) The bearings with ribs can take some axial loads.

Fig. 3.2 Relative Load Capacities of Various Bearing Types

Bearing Types	Relative permissible speed				
	1	4	7	10	13
Deep Groove Ball Bearings	1	4	7	10	13
Angular Contact Ball Bearings	1	4	7	10	13
Cylindrical Roller Bearings	1	4	7	10	13
Needle Roller Bearings	1	4	7	10	13
Tapered Roller Bearings	1	4	7	10	13
Spherical Roller Bearings	1	4	7	10	13
Thrust Ball Bearings	1	4	7	10	13

Remarks ——— Oil bath lubrication  
 - - - - - With special measures to increase speed limit

Fig. 3.3 Relative Permissible Speeds of Various Bearing Types

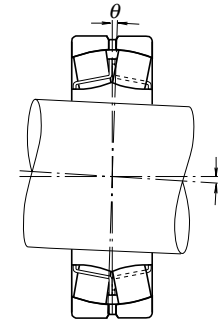

Fig. 3.4 Permissible Misalignment of Spherical Roller Bearings

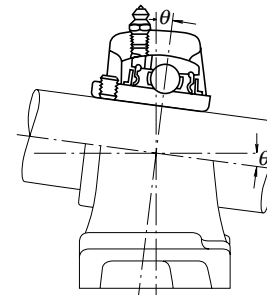

Fig. 3.5 Permissible Misalignment of Ball Bearing Units

Bearing Types	Highest accuracy specified	Tolerance comparison of inner ring radial runout				
		1	2	3	4	5
Deep Groove Ball Bearings	Class 2	1	2	3	4	5
Angular Contact Ball Bearings	Class 2	1	2	3	4	5
Cylindrical Roller Bearings	Class 2	1	2	3	4	5
Tapered Roller Bearings	Class 4	1	2	3	4	5
Spherical Roller Bearings	Normal	1	2	3	4	5

Fig. 3.6 Relative Inner Ring Radial Runout of Highest Accuracy Class for Various Bearing Types

# 4. SELECTION OF BEARING ARRANGEMENT

In general, shafts are supported by only two bearings. When considering the bearing mounting arrangement, the following items must be investigated:

- (1) Expansion and contraction of the shaft caused by temperature variations.
- (2) Ease of bearing mounting and dismounting.
- (3) Misalignment of the inner and outer rings caused by deflection of the shaft or mounting error.
- (4) Rigidity of the entire system including bearings and preloading method.
- (5) Capability to sustain the loads at their proper positions and to transmit them.

## 4.1 Fixed-End and Free-End Bearings

Among the bearings on a shaft, only one can be a "fixed-end" bearing that is used to fix the shaft axially. For this fixed-end bearing, a type which can carry both radial and axial loads must be selected.

Bearings other than the fixed-end one must be "free-end" bearings that carry only radial loads to relieve the shaft's thermal elongation and contraction.

If measures to relieve a shaft's thermal elongation and contraction are insufficient, abnormal axial loads are applied to the bearings, which can cause premature failure.

For free-end bearings, cylindrical roller bearings or needle roller bearings with separable inner and outer rings that are free to move axially (NU, N types, etc.) are recommended. When these types are used, mounting and dismounting are also easier.

When non-separable types are used as free-end bearings, usually the fit between the outer ring and housing is loose to allow axial movement of the running shaft together with the bearing. Sometimes, such elongation is relieved by a loose fitting between the inner ring and shaft.

When the distance between the bearings is short and the influence of the shaft elongation and contraction is negligible, two opposed angular contact ball bearings or tapered roller bearings are used. The axial clearance (possible axial movement) after the mounting is adjusted using nuts or shims.

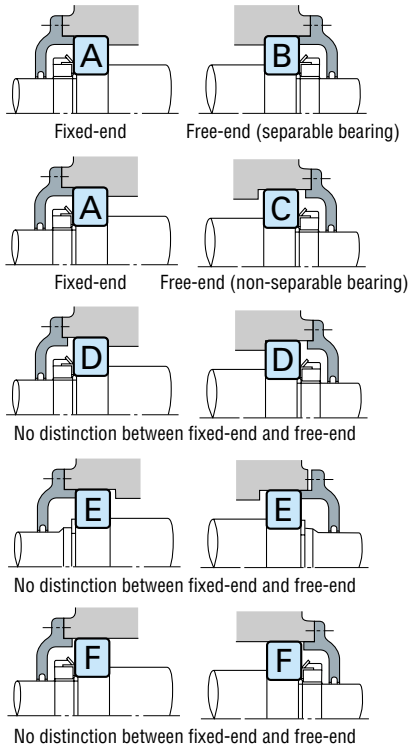

- BEARING A**
- Deep Groove Ball Bearing
  - Matched Angular Contact Ball Bearing
  - Double-Row Angular Contact Ball Bearing
  - Self-Aligning Ball Bearing
  - Cylindrical Roller Bearing with Ribs (NH, NUP types)
  - Double-Row Tapered Roller Bearing
  - Spherical Roller Bearing

- BEARING B**
- Cylindrical Roller Bearing (NU, N types)
  - Needle Roller Bearing (NA type, etc.)

- BEARING C(1)**
- Deep Groove Ball Bearing
  - Matched Angular Contact Ball Bearing (back-to-back)
  - Double-Row Angular Contact Ball Bearing
  - Self-Aligning Ball Bearing
  - Double-Row Tapered Roller Bearing (KBE type)
  - Spherical Roller Bearing

- BEARING D,E(2)**
- Angular Contact Ball Bearing
  - Tapered Roller Bearing
  - Magneto Bearing
  - Cylindrical Roller Bearing (NJ, NF types)

- BEARING F**
- Deep Groove Ball Bearing
  - Self-Aligning Ball Bearing
  - Spherical Roller Bearing

Notes: (1) In the figure, shaft elongation and contraction are relieved at the outside surface of the outer ring, but sometimes it is done at the bore.  
(2) For each type, two bearings are used in opposition.

The distinction between free-end and fixed-end bearings and some possible bearing mounting arrangements for various bearing types are shown in Fig. 4.1.

## 4.2 Example of Bearing Arrangements

Some representative bearing mounting arrangements considering preload and rigidity of the entire assembly, shaft elongation and contraction, mounting error, etc. are shown in Table 4.1.

**Table 4.1 Representative Bearing Mounting Arrangements and Application Examples**

Bearing Arrangements		Remarks	Application Examples
Fixed-end	Free-end		
		<ul style="list-style-type: none"> <li>○ This is a common arrangement in which abnormal loads are not applied to bearings even if the shaft expands or contracts.</li> <li>○ If the mounting error is small, this is suitable for high speeds.</li> </ul>	Medium size electric motors, blowers
		<ul style="list-style-type: none"> <li>○ This can withstand heavy loads and shock loads and can take some axial load.</li> <li>○ Every type of cylindrical roller bearing is separable. This is helpful when interference is necessary for both the inner and outer rings.</li> </ul>	Traction motors for rolling stock
		<ul style="list-style-type: none"> <li>○ This is used when loads are relatively heavy.</li> <li>○ For maximum rigidity of the fixed-end bearing, it is a back-to-back type.</li> <li>○ Both the shaft and housing must have high accuracy and the mounting error must be small.</li> </ul>	Table rollers for steel mills, main spindles of lathes
		<ul style="list-style-type: none"> <li>○ This is also suitable when interference is necessary for both the inner and outer rings. Heavy axial loads cannot be applied.</li> </ul>	Calender rolls of paper making machines, axles of diesel locomotives
		<ul style="list-style-type: none"> <li>○ This is suitable for high speeds and heavy radial loads. Moderate axial loads can also be applied.</li> <li>○ It is necessary to provide some clearance between the outer ring of the deep groove ball bearing and the housing bore in order to avoid subjecting it to radial loads.</li> </ul>	Reduction gears in diesel locomotives

**Fig. 4.1 Bearing Mounting Arrangements and Bearing Types**

Continued on next page

Table 4.1 Representative Bearing Mounting Arrangements and Application Examples (cont'd)

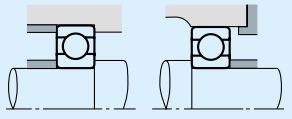
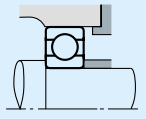
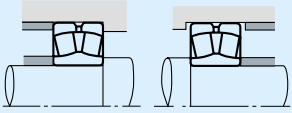
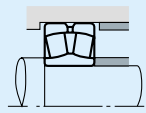
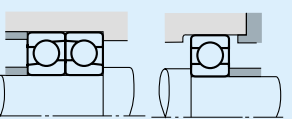
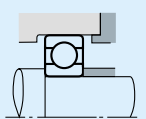
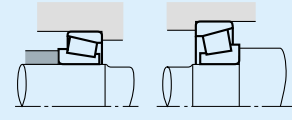
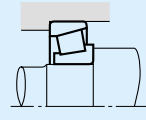
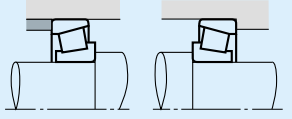
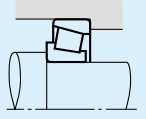
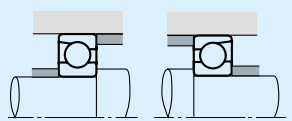
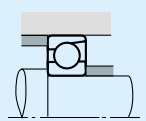
Bearing Arrangements		Remarks	Application Examples
Fixed-end	Free-end		
		<ul style="list-style-type: none"> <li>This is the most common arrangement.</li> <li>It can sustain not only radial loads, but moderate axial loads also.</li> </ul>	Double suction volute pumps, automotive transmissions
		<ul style="list-style-type: none"> <li>This is the most suitable arrangement when there is mounting error or shaft deflection.</li> <li>It is often used for general and industrial applications in which heavy loads are applied.</li> </ul>	Speed reducers, table rollers of steel mills, wheels for overhead travelling cranes
		<ul style="list-style-type: none"> <li>This is suitable when there are rather heavy axial loads in both directions.</li> <li>Double row angular contact bearings may be used instead of an arrangement of two angular contact ball bearings.</li> </ul>	Worm gear reducers
When there is no distinction between fixed-end and free-end		Remarks	Application Examples
		<ul style="list-style-type: none"> <li>This arrangement is widely used since it can withstand heavy loads and shock loads.</li> <li>The back-to-back arrangement is especially good when the distance between bearings is short and moment loads are applied.</li> <li>Front-to-front mounting makes mounting easier when interference is necessary for the inner ring. In general, this arrangement is good when there is mounting error.</li> <li>To use this arrangement with a preload, attention must be paid to the amount of preload and clearance adjustment.</li> </ul>	Pinion shafts of automotive differential gears, automotive front and rear axles, worm gear reducers
			
		<ul style="list-style-type: none"> <li>This is used at high speeds when radial loads are not so heavy and axial loads are relatively heavy.</li> <li>It provides good rigidity of the shaft by preloading.</li> <li>For moment loads, back-to-back mounting is better than front-to-front mounting.</li> </ul>	Grinding wheel shafts

Continued on next page

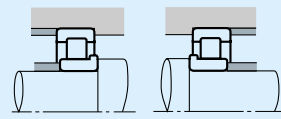
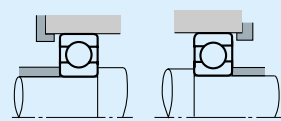
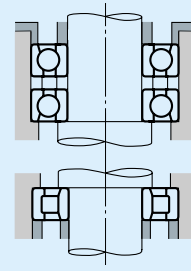
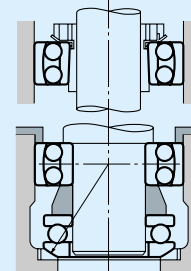
When there is no distinction between fixed-end and free-end	Remarks	Application Examples
 <p>NJ + NJ mounting</p>	<ul style="list-style-type: none"> <li>This can withstand heavy loads and shock loads.</li> <li>It can be used if interference is necessary for both the inner and outer rings.</li> <li>Care must be taken so the axial clearance doesn't become too small during running.</li> <li>NF type + NF type mounting is also possible.</li> </ul>	Final reduction gears of construction machines
	<ul style="list-style-type: none"> <li>Sometimes a spring is used at the side of the outer ring of one bearing.</li> </ul>	Small electric motors, small speed reducers, small pumps
Vertical arrangements		Application Examples
	<ul style="list-style-type: none"> <li>Matched angular contact ball bearings are on the fixed end.</li> <li>Cylindrical roller bearing is on the free end.</li> </ul>	Vertical electric motors
	<ul style="list-style-type: none"> <li>The spherical center of the self-aligning seat must coincide with that of the self-aligning ball bearing.</li> <li>The upper bearing is on the free end.</li> </ul>	Vertical openers (spinning and weaving machines)



## 5. SELECTION OF BEARING SIZE

### 5.1 Bearing Life

The various functions required of rolling bearings vary according to the bearing application. These functions must be performed for a prolonged period. Even if bearings are properly mounted and correctly operated, they will eventually fail to perform satisfactorily due to an increase in noise and vibration, loss of running accuracy, deterioration of grease, or fatigue flaking of the rolling surfaces.

Bearing life, in the broad sense of the term, is the period during which bearings continue to operate and to satisfy their required functions. This bearing life may be defined as noise life, abrasion life, grease life, or rolling fatigue life, depending on which one causes loss of bearing service.

Aside from the failure of bearings to function due to natural deterioration, bearings may fail when conditions such as heat-seizure, fracture, scoring of the rings, damage of the seals or the cage, or other damage occurs.

Conditions such as these should not be interpreted as normal bearing failure since they often occur as a result of errors in bearing selection, improper design or manufacture of the bearing surroundings, incorrect mounting, or insufficient maintenance.

#### 5.1.1 Rolling Fatigue Life and Basic Rating Life

When rolling bearings are operated under load, the raceways of their inner and outer rings and rolling elements are subjected to repeated cyclic stress. Because of metal fatigue of the rolling contact surfaces of the raceways and rolling elements, scaly particles may separate from the bearing material (Fig. 5.1). This phenomenon is called "flaking". Rolling fatigue life is represented by the total number of revolutions at which time the bearing surface will start flaking due to stress. This is called fatigue life. As shown in Fig. 5.2, even for seemingly identical bearings, which are of the same type, size, and material and receive the same heat treatment and other processing, the rolling fatigue life varies greatly even under identical operating conditions. This is because the flaking of materials due to fatigue is subject to many other variables. Consequently, "basic rating life", in which rolling fatigue life is treated as a statistical phenomenon, is used in preference to actual rolling fatigue life.

Suppose a number of bearings of the same type are operated individually under the same conditions. After a certain period of time, 10% of them fail as a result of flaking caused by rolling fatigue. The total number of revolutions at this point is defined as the basic rating life or, if the speed is constant, the basic rating life is often expressed by the total number of operating hours completed when 10% of the bearings become inoperable due to flaking.

In determining bearing life, basic rating life is often the only factor considered. However, other factors must also be taken into account. For example, the grease life

of grease-prelubricated bearings (refer to Section 12, Lubrication, Page A107) can be estimated. Since noise life and abrasion life are judged according to individual standards for different applications, specific values for noise or abrasion life must be determined empirically.

### 5.2 Basic Load Rating and Fatigue Life

#### 5.2.1 Basic Load Rating

The basic load rating is defined as the constant load applied on bearings with stationary outer rings that the inner rings can endure for a rating life of one million revolutions ( $10^6$  rev). The basic load rating of radial bearings is defined as a central radial load of constant direction and magnitude, while the basic load rating of thrust bearings is defined as an axial load of constant magnitude in the same direction as the central axis. The load ratings are listed under  $C_r$  for radial bearings and  $C_a$  for thrust bearings in the dimension tables.

#### 5.2.2 Machinery in which Bearings are Used and Projected Life

It is not advisable to select bearings with unnecessarily high load ratings, for such bearings may be too large and uneconomical. In addition, the bearing life alone should not be the deciding factor in the selection of bearings. The strength, rigidity, and design of the shaft



Fig. 5.1 Example of Flaking

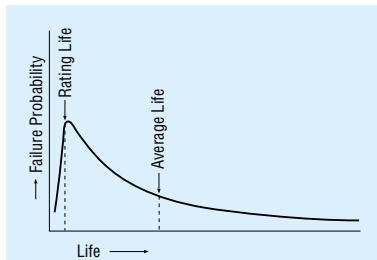

Fig. 5.2 Failure Probability and Bearing Life

Table 5.1 Fatigue Life Factor  $f_h$  for Various Bearing Applications

Operating Periods	Fatigue Life Factor $f_h$				
	~3	2~4	3~5	4~7	6~
Infrequently used or only for short periods	• Small motors for home appliances like vacuum cleaners and washing machines • Hand power tools	• Agricultural equipment			
Used only occasionally but reliability is important		• Motors for home heaters and air conditioners • Construction equipment	• Conveyors • Elevator cable sheaves		
Used intermittently for relatively long periods	• Rolling mill roll necks	• Small motors • Deck cranes • General cargo cranes • Pinion stands • Passenger cars	• Factory motors • Machine tools • Transmissions • Vibrating screens • Crushers	• Crane sheaves • Compressors • Specialized transmissions	
Used intermittently for more than eight hours daily		• Escalators	• Centrifugal separators • Air conditioning equipment • Blowers • Woodworking machines • Large motors • Axle boxes on railway rolling stock	• Mine hoists • Press flywheels • Railway traction motors • Locomotive axle boxes	• Paper making machines
Used continuously and high reliability is important					• Waterworks pumps • Electric power stations • Mine draining pumps

on which the bearings are to be mounted should also be considered. Bearings are used in a wide range of applications and the design life varies with specific applications and operating conditions. Table 5.1 gives an empirical fatigue life factor derived from customary operating experience for various machines. Also refer to Table 5.2.

#### 5.2.3 Selection of Bearing Size Based on Basic Load Rating

The following relation exists between bearing load and basic rating life:

$$\text{For ball bearings } L = \left(\frac{C}{P}\right)^3 \dots\dots\dots (5.1)$$

$$\text{For roller bearings } L = \left(\frac{C}{P}\right)^{10/3} \dots\dots\dots (5.2)$$

where  $L$ : Basic rating life ( $10^6$  rev)  
 $P$ : Bearing load (equivalent load) (N), {kgf}  
 .....(Refer to Page A30)  
 $C$ : Basic load rating (N), {kgf}  
 For radial bearings,  $C$  is written  $C_r$   
 For thrust bearings,  $C$  is written  $C_a$

In the case of bearings that run at a constant speed, it is convenient to express the fatigue life in terms of hours. In general, the fatigue life of bearings used in automobiles and other vehicles is given in terms of mileage.

By designating the basic rating life as  $L_h$  (h), bearing speed as  $n$  (rpm), fatigue life factor as  $f_h$ , and speed factor as  $f_n$ , the relations shown in Table 5.2 are obtained:

Table 5.2 Basic Rating Life, Fatigue Life Factor and Speed Factor

Life Parameters	Ball Bearings	Roller Bearings
Basic Rating Life	$L_h = \frac{10^6}{60n} \left(\frac{C}{P}\right)^3 = 500f_h^3$	$L_h = \frac{10^6}{60n} \left(\frac{C}{P}\right)^{10/3} = 500f_h^{10/3}$
Fatigue Life Factor	$f_h = f_n \frac{C}{P}$	$f_h = f_n \frac{C}{P}$
Speed Factor	$f_n = \left(\frac{10^6}{500 \times 60n}\right)^{1/3}$ $= (0.03n)^{-1/3}$	$f_n = \left(\frac{10^6}{500 \times 60n}\right)^{3/10}$ $= (0.03n)^{-3/10}$

$n, f_n$ .....Fig. 5.3 (See Page A26), Appendix Table 12 (See Page C24)

$L_h, f_h$ .....Fig. 5.4 (See Page A26), Appendix Table 13 (See Page C25)

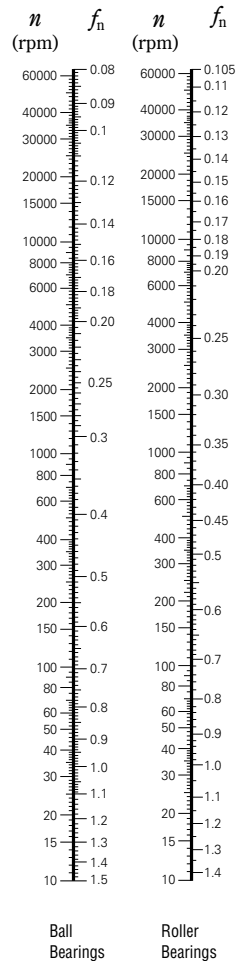

Fig. 5.3 Bearing Speed and Speed Factor

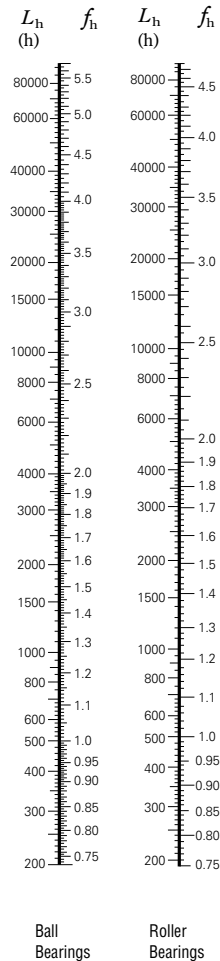

Fig. 5.4 Fatigue Life Factor and Fatigue Life

If the bearing load  $P$  and speed  $n$  are known, determine a fatigue life factor  $f_h$  appropriate for the projected life of the machine and then calculate the basic load rating  $C$  by means of the following equation.

$$C = \frac{f_h \cdot P}{f_n} \dots\dots\dots(5.3)$$

A bearing which satisfies this value of  $C$  should then be selected from the bearing tables.

**5.2.4 Temperature Adjustment for Basic Load Rating**

If rolling bearings are used at high temperature, the hardness of the bearing steel decreases. Consequently, the basic load rating, which depends on the physical properties of the material, also decreases. Therefore, the basic load rating should be adjusted for the higher temperature using the following equation:

$$C_t = f_t \cdot C \dots\dots\dots(5.4)$$

where  $C_t$ : Basic load rating after temperature correction (N), {kgf}

$f_t$ : Temperature factor (See Table 5.3.)

$C$ : Basic load rating before temperature adjustment (N), {kgf}

If large bearings are used at higher than 120°C, they must be given special dimensional stability heat treatment to prevent excessive dimensional changes. The basic load rating of bearings given such special dimensional stability heat treatment may become lower than the basic load rating listed in the bearing tables.

Table 5.3 Temperature Factor  $f_t$

Bearing Temperature °C	125	150	175	200	250
Temperature Factor $f_t$	1.00	1.00	0.95	0.90	0.75

**5.2.5 Correction of Basic Rating Life**

As described previously, the basic equations for calculating the basic rating life are as follows:

For ball bearings  $L_{10} = \left(\frac{C}{P}\right)^3 \dots\dots\dots(5.5)$

For roller bearings  $L_{10} = \left(\frac{C}{P}\right)^{\frac{10}{3}} \dots\dots\dots(5.6)$

The  $L_{10}$  life is defined as the basic rating life with a statistical reliability of 90%. Depending on the machines in which the bearings are used, sometimes a reliability higher than 90% may be required. However, recent improvements in bearing material have greatly extended the fatigue life. In addition, the development of the Elasto-Hydrodynamic Theory of Lubrication proves that the thickness of the lubricating film in the contact zone between rings and rolling elements greatly influences bearing life. To reflect such improvements in the calculation of fatigue life, the basic rating life is adjusted using the following adjustment factors:

$$L_{na} = a_1 a_2 a_3 L_{10} \dots\dots\dots(5.7)$$

where  $L_{na}$ : Adjusted rating life in which reliability, material improvements, lubricating conditions, etc. are considered

$L_{10}$ : Basic rating life with a reliability of 90%

$a_1$ : Life adjustment factor for reliability

$a_2$ : Life adjustment factor for special bearing properties

$a_3$ : Life adjustment factor for operating conditions

The life adjustment factor for reliability,  $a_1$ , is listed in Table 5.4 for reliabilities higher than 90%.

The life adjustment factor for special bearing properties,  $a_2$ , is used to reflect improvements in bearing steel.

NSK now uses vacuum degassed bearing steel, and the results of tests by NSK show that life is greatly improved when compared with earlier materials. The basic load ratings  $C_r$  and  $C_a$  listed in the bearing tables were calculated considering the extended life achieved by improvements in materials and manufacturing techniques. Consequently, when estimating life using Equation (5.7), it is sufficient to assume that is greater than one.

Table 5.4 Reliability Factor  $a_1$

Reliability (%)	90	95	96	97	98	99
$a_1$	1.00	0.62	0.53	0.44	0.33	0.21

The life adjustment factor for operating conditions  $a_3$  is used to adjust for various factors, particularly lubrication. If there is no misalignment between the inner and outer rings and the thickness of the lubricating film in the contact zones of the bearing is sufficient, it is possible for  $a_3$  to be greater than one; however,  $a_3$  is less than one in the following cases:

- When the viscosity of the lubricant in the contact zones between the raceways and rolling elements is low.
- When the circumferential speed of the rolling elements is very slow.
- When the bearing temperature is high.
- When the lubricant is contaminated by water or foreign matter.
- When misalignment of the inner and outer rings is excessive.

It is difficult to determine the proper value for  $a_3$  for specific operating conditions because there are still many unknowns. Since the special bearing property factor  $a_2$  is also influenced by the operating conditions, there is a proposal to combine  $a_2$  and  $a_3$  into one quantity ( $a_2 \times a_3$ ), and not consider them independently. In this case, under normal lubricating and operating conditions, the product ( $a_2 \times a_3$ ) should be assumed equal to one. However, if the viscosity of the lubricant is too low, the value drops to as low as 0.2.

If there is no misalignment and a lubricant with high viscosity is used so sufficient fluid-film thickness is secured, the product of ( $a_2 \times a_3$ ) may be about two.

When selecting a bearing based on the basic load rating, it is best to choose an  $a_1$  reliability factor appropriate for the projected use and an empirically determined  $C/P$  or  $f_h$  value derived from past results for lubrication, temperature, mounting conditions, etc. in similar machines.

The basic rating life equations (5.1), (5.2), (5.5), and (5.6) give satisfactory results for a broad range of bearing loads. However, extra heavy loads may cause detrimental plastic deformation at ball/raceway contact points. When  $P_r$  exceeds  $C_{or}$  (Basic static load rating) or 0.5  $C_r$ , whichever is smaller, for radial bearings or  $P_a$  exceeds 0.5  $C_a$  for thrust bearings, please consult NSK to establish the applicability of the rating fatigue life equations.



5.3 Calculation of Bearing Loads

The loads applied on bearings generally include the weight of the body to be supported by the bearings, the weight of the revolving elements themselves, the transmission power of gears and belting, the load produced by the operation of the machine in which the bearings are used, etc. These loads can be theoretically calculated, but some of them are difficult to estimate. Therefore, it becomes necessary to correct the estimated using empirically derived data.

5.3.1 Load Factor

When a radial or axial load has been mathematically calculated, the actual load on the bearing may be greater than the calculated load because of vibration and shock present during operation of the machine. The actual load may be calculated using the following equation:

$$\left. \begin{aligned} F_r &= f_w \cdot F_{rc} \\ F_a &= f_w \cdot F_{ac} \end{aligned} \right\} \dots\dots\dots (5.8)$$

where  $F_r, F_a$  : Loads applied on bearing (N), {kgf}

$F_{rc}, F_{ac}$  : Theoretically calculated load (N), {kgf}

$f_w$  : Load factor

The values given in Table 5.5 are usually used for the load factor  $f_w$ .

5.3.2 Bearing Loads in Belt or Chain Transmission Applications

The force acting on the pulley or sprocket wheel when power is transmitted by a belt or chain is calculated using the following equations.

$$\left. \begin{aligned} M &= 9\,550\,000H / n \dots (N \cdot mm) \\ &= 974\,000H / n \dots \{kgf \cdot mm\} \end{aligned} \right\} \dots\dots\dots (5.9)$$

$$P_k = M / r \dots\dots\dots (5.10)$$

where  $M$  : Torque acting on pulley or sprocket wheel (N · mm), {kgf · mm}

$P_k$  : Effective force transmitted by belt or chain (N), {kgf}

$H$  : Power transmitted (kW)

$n$  : Speed (rpm)

$r$  : Effective radius of pulley or sprocket wheel (mm)

When calculating the load on a pulley shaft, the belt tension must be included. Thus, to calculate the actual load  $K_b$  in the case of a belt transmission, the effective transmitting power is multiplied by the belt factor  $f_b$ , which represents the belt tension. The values of the belt factor  $f_b$  for different types of belts are shown in Table 5.6.

$$K_b = f_b \cdot P_k \dots\dots\dots (5.11)$$

In the case of a chain transmission, the values corresponding to  $f_b$  should be 1.25 to 1.5.

5.3.3 Bearing Loads in Gear Transmission Applications

The loads imposed on gears in gear transmissions vary according to the type of gears used. In the simplest case of spur gears, the load is calculated as follows:

$$\left. \begin{aligned} M &= 9\,550\,000H / n \dots (N \cdot mm) \\ &= 974\,000H / n \dots \{kgf \cdot mm\} \end{aligned} \right\} \dots\dots\dots (5.12)$$

$$P_k = M / r \dots\dots\dots (5.13)$$

$$S_k = P_k \tan \theta \dots\dots\dots (5.14)$$

$$K_c = \sqrt{P_k^2 + S_k^2} = P_k \sec \theta \dots\dots\dots (5.15)$$

where  $M$  : Torque applied to gear (N · mm), {kgf · mm}

$P_k$  : Tangential force on gear (N), {kgf}

$S_k$  : Radial force on gear (N), {kgf}

$K_c$  : Combined force imposed on gear (N), {kgf}

$H$  : Power transmitted (kW)

$n$  : Speed (rpm)

$r$  : Pitch circle radius of drive gear (mm)

$\theta$  : Pressure angle

In addition to the theoretical load calculated above, vibration and shock (which depend on how accurately the gear is finished) should be included using the gear factor  $f_g$  by multiplying the theoretically calculated load by this factor.

The values of  $f_g$  should generally be those in Table 5.7. When vibration from other sources accompanies gear operation, the actual load is obtained by multiplying the load factor by this gear factor.

Table 5.7 Values of Gear Factor  $f_g$

Gear Finish Accuracy	$f_g$
Precision ground gears	1 ~ 1.1
Ordinary machined gears	1.1 ~ 1.3

5.3.4 Load Distribution on Bearings

In the simple examples shown in Figs. 5.5 and 5.6. The radial loads on bearings I and II can be calculated using the following equations:

$$F_{CI} = \frac{b}{c} K \dots\dots\dots (5.16)$$

$$F_{CII} = \frac{a}{c} K \dots\dots\dots (5.17)$$

where  $F_{CI}$  : Radial load applied on bearing I (N), {kgf}

$F_{CII}$  : Radial load applied on bearing II (N), {kgf}

$K$  : Shaft load (N), {kgf}

When these loads are applied simultaneously, first the radial load for each should be obtained, and then, the sum of the vectors may be calculated according to the load direction.

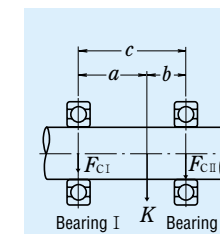

Fig. 5.5 Radial Load Distribution (1)

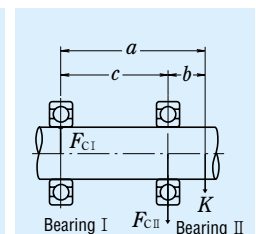

Fig. 5.6 Radial Load Distribution (2)

Table 5.5 Values of Load Factor  $f_w$

Operating Conditions	Typical Applications	$f_w$
Smooth operation free from shocks	Electric motors, Machine tools, Air conditioners	1 ~ 1.2
Normal operation	Air blowers, Compressors, Elevators, Cranes, Paper making machines	1.2 ~ 1.5
Operation accompanied by shock and vibration	Construction equipment, Crushers, Vibrating screens, Rolling mills	1.5 ~ 3

Table 5.6 Belt Factor  $f_b$

Type of Belt	$f_b$
Toothed belts	1.3 ~ 2
V belts	2 ~ 2.5
Flat belts with tension pulley	2.5 ~ 3
Flat belts	4 ~ 5

5.3.5 Average of Fluctuating Load

When the load applied on bearings fluctuates, an average load which will yield the same bearing life as the fluctuating load should be calculated.

(1) When the relation between load and rotating speed is divided into the following steps (Fig. 5.7)

Load  $F_1$  : Speed  $n_1$  ; Operating time  $t_1$

Load  $F_2$  : Speed  $n_2$  ; Operating time  $t_2$

⋮

Load  $F_n$  : Speed  $n_n$  ; Operating time  $t_n$

Then, the average load  $F_m$  may be calculated using the following equation:

$$F_m = \sqrt[p]{\frac{F_1^p n_1 t_1 + F_2^p n_2 t_2 + \dots + F_n^p n_n t_n}{n_1 t_1 + n_2 t_2 + \dots + n_n t_n}} \dots\dots\dots (5.18)$$

where  $F_m$  : Average fluctuating load (N), {kgf}

$p = 3$  for ball bearings

$p = 10/3$  for roller bearings

The average speed  $n_m$  may be calculated as follows:

$$n_m = \frac{n_1 t_1 + n_2 t_2 + \dots + n_n t_n}{t_1 + t_2 + \dots + t_n} \dots\dots\dots(5.19)$$

(2) When the load fluctuates almost linearly (Fig. 5.8), the average load may be calculated as follows:

$$F_m \doteq \frac{1}{3} (F_{\min} + 2F_{\max}) \dots\dots\dots(5.20)$$

where  $F_{\min}$ : Minimum value of fluctuating load (N), {kgf}

$F_{\max}$ : Maximum value of fluctuating load (N), {kgf}

(3) When the load fluctuation is similar to a sine wave (Fig. 5.9), an approximate value for the average load  $F_m$  may be calculated from the following equation:

In the case of Fig. 5.9 (a)

$$F_m \doteq 0.65 F_{\max} \dots\dots\dots(5.21)$$

In the case of Fig. 5.9 (b)

$$F_m \doteq 0.75 F_{\max} \dots\dots\dots(5.22)$$

(4) When both a rotating load and a stationary load are applied (Fig. 5.10).

$F_R$ : Rotating load (N), {kgf}

$F_S$ : Stationary load (N), {kgf}

An approximate value for the average load  $F_m$  may be calculated as follows:

a) Where  $F_R \geq F_S$

$$F_m \doteq F_R + 0.3F_S + 0.2 \frac{F_S^2}{F_R} \dots\dots\dots(5.23)$$

b) Where  $F_R < F_S$

$$F_m \doteq F_S + 0.3F_R + 0.2 \frac{F_R^2}{F_S} \dots\dots\dots(5.24)$$

### 5.4 Equivalent Load

In some cases, the loads applied on bearings are purely radial or axial loads; however, in most cases, the loads are a combination of both. In addition, such loads usually fluctuate in both magnitude and direction. In such cases, the loads actually applied on bearings cannot be used for bearing life calculations; therefore, a hypothetical load that has a constant magnitude and passes through the center of the bearing, and will give the same bearing life that the bearing would attain under actual conditions of load and rotation should be estimated. Such a hypothetical load is called the equivalent load.

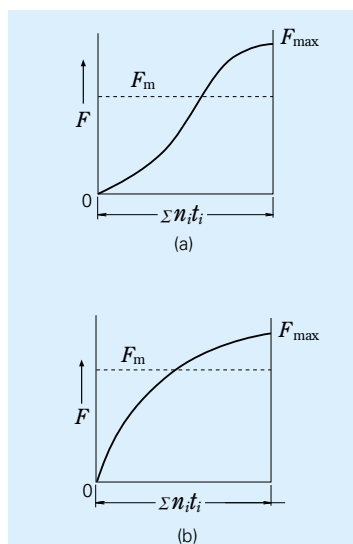

Fig. 5.9 Sinusoidal Load Variation

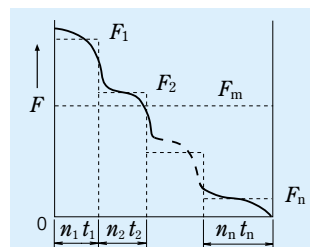

Fig. 5.7 Incremental Load Variation

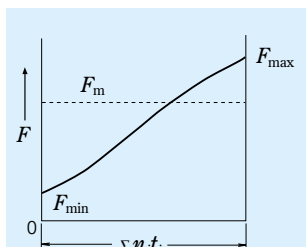

Fig. 5.8 Simple Load Fluctuation

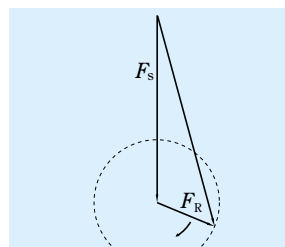

Fig. 5.10 Rotating Load and Stationary Load

#### 5.4.1 Calculation of Equivalent Loads

The equivalent load on radial bearings may be calculated using the following equation:

$$P = XF_r + YF_a \dots\dots\dots(5.25)$$

where  $P$ : Equivalent Load (N), {kgf}

$F_r$ : Radial load (N), {kgf}

$F_a$ : Axial load (N), {kgf}

$X$ : Radial load factor

$Y$ : Axial load factor

The values of  $X$  and  $Y$  are listed in the bearing tables. The equivalent radial load for radial roller bearings with  $\alpha = 0^\circ$  is

$$P = F_r$$

In general, thrust ball bearings cannot take radial loads, but spherical thrust roller bearings can take some radial loads. In this case, the equivalent load may be calculated using the following equation:

$$P = F_a + 1.2F_r \dots\dots\dots(5.26)$$

where  $\frac{F_r}{F_a} \leq 0.55$

#### 5.4.2 Axial Load Components in Angular Contact Ball Bearings and Tapered Roller Bearings

The effective load center of both angular contact ball bearings and tapered roller bearings is at the point of intersection of the shaft center line and a line representing the load applied on the rolling element by the outer ring as shown in Fig. 5.11. This effective load

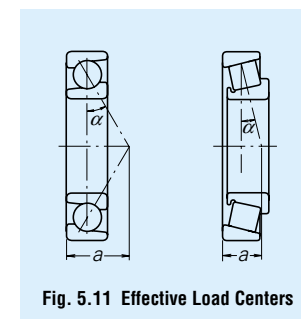

Fig. 5.11 Effective Load Centers

center for each bearing is listed in the bearing tables. When radial loads are applied to these types of bearings, a component of load is produced in the axial direction. In order to balance this component load, bearings of the same type are used in pairs, placed face to face or back to back. These axial loads can be calculated using the following equation:

$$F_{ai} = \frac{0.6}{Y} F_r \dots\dots\dots(5.27)$$

where  $F_{ai}$ : Component load in the axial direction (N), {kgf}

$F_r$ : Radial load (N), {kgf}

$Y$ : Axial load factor

Assume that radial loads  $F_{rI}$  and  $F_{rII}$  are applied on bearings I and II (Fig. 5.12) respectively, and an external axial load  $F_{ae}$  is applied as shown. If the axial load factors are  $Y_I, Y_{II}$  and the radial load factor is  $X$ , then the equivalent loads  $P_I, P_{II}$  may be calculated as follows:

where  $F_{ae} + \frac{0.6}{Y_{II}} F_{rII} \geq \frac{0.6}{Y_I} F_{rI}$

$$P_I = XF_{rI} + Y_I \left( F_{ae} + \frac{0.6}{Y_{II}} F_{rII} \right) \dots\dots\dots(5.28)$$

$$P_{II} = F_{rII}$$

where  $F_{ae} + \frac{0.6}{Y_{II}} F_{rII} < \frac{0.6}{Y_I} F_{rI}$

$$P_I = F_{rI}$$

$$P_{II} = XF_{rII} + Y_{II} \left( \frac{0.6}{Y_I} F_{rI} - F_{ae} \right) \dots\dots\dots(5.29)$$

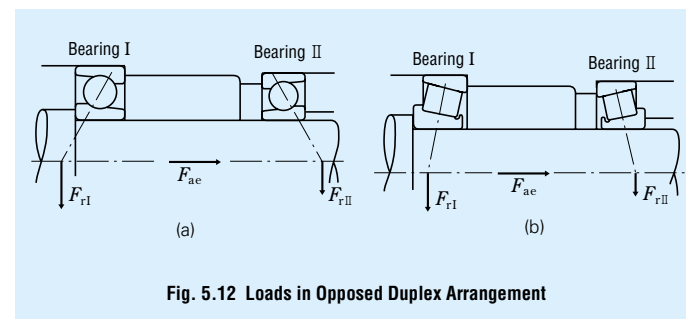

Fig. 5.12 Loads in Opposed Duplex Arrangement

**5.5 Static Load Ratings and Static Equivalent Loads**

**5.5.1 Static Load Ratings**

When subjected to an excessive load or a strong shock load, rolling bearings may incur a local permanent deformation of the rolling elements and permanent deformation of the rolling elements and raceway surface if the elastic limit is exceeded. The nonelastic deformation increases in area and depth as the load increases, and when the load exceeds a certain limit, the smooth running of the bearing is impeded. The basic static load rating is defined as that static load which produces the following calculated contact stress at the center of the contact area between the rolling element subjected to the maximum stress and the raceway surface.

- For self-aligning ball bearings 4 600MPa  
{469kgf/mm<sup>2</sup>}
- For other ball bearings 4 200MPa  
{428kgf/mm<sup>2</sup>}
- For roller bearings 4 000MPa  
{408kgf/mm<sup>2</sup>}

In this most heavily stressed contact area, the sum of the permanent deformation of the rolling element and that of the raceway is nearly 0.0001 times the rolling element's diameter. The basic static load rating  $C_o$  is written  $C_{or}$  for radial bearings and  $C_{oa}$  for thrust bearings in the bearing tables. In addition, following the modification of the criteria for basic static load rating by ISO, the new  $C_o$  values for NSK's ball bearings became about 0.8 to 1.3 times the past values and those for roller bearings about 1.5 to 1.9 times. Consequently, the values of permissible static load factor  $f_s$  have also changed, so please pay attention to this.

**5.5.2 Static Equivalent Loads**

The static equivalent load is a hypothetical load that produces a contact stress equal to the above maximum stress under actual conditions, while the bearing is stationary (including very slow rotation or oscillation), in the area of contact between the most heavily stressed rolling element and bearing raceway. The static radial load passing through the bearing center is taken as the static equivalent load for radial bearings, while the static axial load in the direction coinciding with the central axis is taken as the static equivalent load for thrust bearings.

(a) Static equivalent load on radial bearings

The greater of the two values calculated from the following equations should be adopted as the static equivalent load on radial bearings.

$$P_o = X_o F_r + Y_o F_a \dots\dots\dots(5.30)$$

$$P_o = F_r \dots\dots\dots(5.31)$$

where  $P_o$  : Static equivalent load (N), {kgf}  
 $F_r$  : Radial load (N), {kgf}  
 $F_a$  : Axial load (N), {kgf}  
 $X_o$  : Static radial load factor  
 $Y_o$  : Static axial load factor

(b) Static equivalent load on thrust bearings

$$P_o = X_o F_r + F_a \quad \alpha \neq 90^\circ \dots\dots\dots(5.32)$$

where  $P_o$  : Static equivalent load (N), {kgf}  
 $\alpha$  : Contact angle

When  $F_a < X_o F_r$ , this equation becomes less accurate. The values of  $X_o$  and  $Y_o$  for Equations (5.30) and (5.32) are listed in the bearing tables.

The static equivalent load for thrust roller bearings with

$$\alpha = 90^\circ \text{ is } P_o = F_a$$

**5.5.3 Permissible Static Load Factor**

The permissible static equivalent load on bearings varies depending on the basic static load rating and also their application and operating conditions. The permissible static load factor  $f_s$  is a safety factor that is applied to the basic static load rating, and it is defined by the ratio in Equation (5.33). The generally recommended values of  $f_s$  are listed in Table 5.8. Conforming to the modification of the static load rating, the values of  $f_s$  were revised, especially for bearings for which the values of  $C_o$  were increased, please keep this in mind when selecting bearings.

$$f_s = \frac{C_o}{P_o} \dots\dots\dots(5.33)$$

where  $C_o$  : Basic static load rating (N), {kgf}  
 $P_o$  : Static equivalent load (N), {kgf}

For spherical thrust roller bearings, the values of  $f_s$  should be greater than 4.

**Table 5.8 Values of Permissible Static Load Factor  $f_s$**

Operating Conditions	Lower Limit of $f_s$	
	Ball Bearings	Roller Bearings
Low-noise applications	2	3
Bearings subjected to vibration and shock loads	1.5	2
Standard operating conditions	1	1.5

**5.6 Maximum Permissible Axial Loads for Cylindrical Roller Bearings**

Cylindrical roller bearings having inner and outer rings with ribs, loose ribs or thrust collars are capable of sustaining radial loads and limited axial loads simultaneously. The maximum permissible axial load is limited by an abnormal temperature rise or heat seizure due to sliding friction between the end faces of the rollers and rib face.

The maximum permissible axial load for bearings of diameter series 3 that are continuously loaded and lubricated with grease or oil is shown in Fig. 5.13.

Grease lubrication (Empirical equation)

$$C_A = 9.8f \left\{ \frac{900(kd)^2}{n+1500} - 0.023 \times (kd)^{2.5} \right\} \dots\dots(5.34)$$

$$= f \left\{ \frac{900(kd)^2}{n+1500} - 0.023 \times (kd)^{2.5} \right\} \dots\dots\{kgf\}$$

Oil lubrication (Empirical equation)

$$C_A = 9.8f \left\{ \frac{490(kd)^2}{n+1000} - 0.000135 \times (kd)^{3.4} \right\} \dots\dots(5.35)$$

$$= f \left\{ \frac{490(kd)^2}{n+1000} - 0.000135 \times (kd)^{3.4} \right\} \dots\dots\{kgf\}$$

where  $C_A$  : Permissible axial load (N), {kgf}  
 $d$  : Bearing bore diameter (mm)  
 $n$  : Speed (rpm)

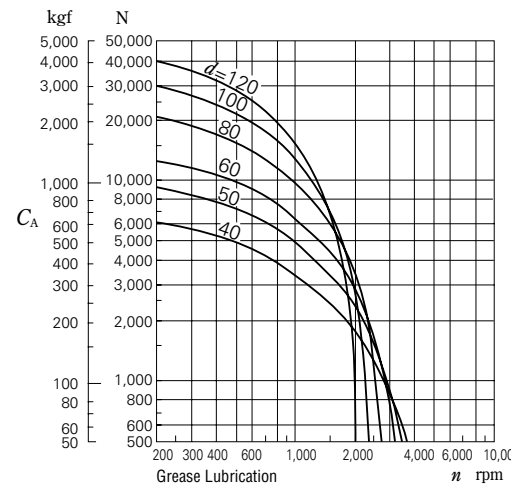

$f$ : Load Factor		$k$ : Size Factor	
Loading Interval	Value of $f$	Diameter series	Value of $k$
Continuous	1	2	0.75
Intermittent	2	3	1
Short time only	3	4	1.2

In addition, for cylindrical roller bearings to have a stable axial-load carrying capacity, the following precautions are required for the bearings and their surroundings:

- When axial loads are applied, radial loads must also be applied.
- Sufficient lubricant must exist between the roller end faces and ribs.
- Superior extreme-pressure grease must be used.
- Sufficient running-in should be done.
- The mounting accuracy must be good.
- The radial clearance should not be more than necessary.

In cases where the bearing speed is extremely slow, the speed exceeds the limiting speed by more than 50%, or the bore diameter is more than 200mm, careful study is necessary for each case regarding lubrication, cooling, etc. In such a case, please consult with NSK.

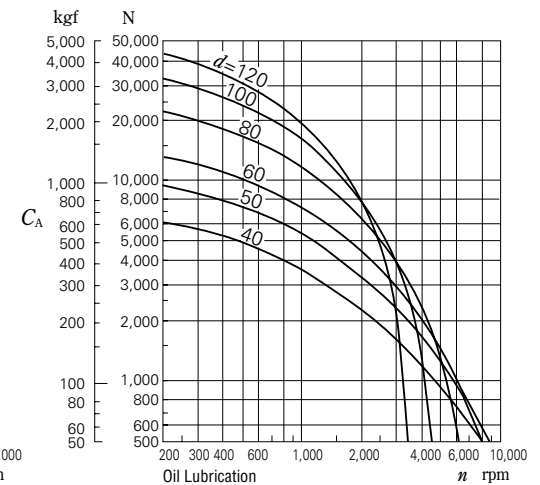

**Fig. 5.13 Permissible Axial Load for Cylindrical Roller Bearings**  
 For Diameter Series 3 bearings ( $k=1.0$ ) operating under a continuous load and lubricated with grease or oil.

5.7 Examples of Bearing Calculations

(Example 1)

Obtain the fatigue life factor  $f_h$  of single-row deep groove ball bearing **6208** when it is used under a radial load  $F_r=2\,500\text{ N}$ , {255kgf} and speed  $n=900\text{rpm}$ .

The basic load rating  $C_r$  of **6208** is 29 100N, {2970kgf} (Bearing Table, Page B10). Since only a radial load is applied, the equivalent load  $P$  may be obtained as follows:

$$P = F_r = 2\,500\text{ N}, \{255\text{kgf}\}$$

Since the speed is  $n = 900\text{rpm}$ , the speed factor  $f_n$  can be obtained from the equation in Table 5.2 (Page A25) or Fig. 5.3(Page A26).

$$f_n = 0.333$$

The fatigue life factor  $f_h$ , under these conditions, can be calculated as follows:

$$f_h = f_n \frac{C_r}{P} = 0.333 \times \frac{29\,100}{2\,500} = 3.88$$

This value is suitable for industrial applications, air conditioners being regularly used, etc., and according to the equation in Table 5.2 or Fig. 5.4 (Page A26), it corresponds approximately to 29 000 hours of service life.

(Example 2)

Select a single-row deep groove ball bearing with a bore diameter of 50 mm and outside diameter under 100 mm that satisfies the following conditions:

Radial load  $F_r = 3\,000\text{ N}$ , {306kgf}

Speed  $n = 1\,900\text{rpm}$

Basic rating life  $L_h \geq 10\,000\text{h}$

The fatigue life factor  $f_h$  of ball bearings with a rating fatigue life longer than 10 000 hours is  $f_h \geq 2.72$ . Because  $f_n = 0.26$ ,  $P = F_r = 3\,000\text{ N}$ , {306kgf}

$$f_h = f_n \frac{C_r}{P} = 0.26 \times \frac{C_r}{3\,000} \geq 2.72$$

therefore,  $C_r \geq 2.72 \times \frac{3\,000}{0.26} = 31\,380\text{ N}$ , {3200kgf}

Among the data listed in the bearing table on Page B12, **6210** should be selected as one that satisfies the above conditions.

(Example 3)

Obtain  $C_r/P$  or fatigue life factor  $f_h$  when an axial load  $F_a=1\,000\text{ N}$ , {102kgf} is added to the conditions of (Example 1)

When the radial load  $F_r$  and axial load  $F_a$  are applied on single-row deep groove ball bearing **6208**, the dynamic equivalent load  $P$  should be calculated in accordance with the following procedure.

Obtain the radial load factor  $X$ , axial load factor  $Y$  and constant  $e$  obtainable, depending on the magnitude of  $f_o F_a / C_{or}$ , from the table above the single-row deep groove ball bearing table.

The basic static load rating  $C_{or}$  of ball bearing **6208** is 17 900 N, {1 820kgf} (Page B10)

$$f_o F_a / C_{or} = 14.0 \times 1\,000 / 17\,900 = 0.782$$

$$e \approx 0.26$$

and  $F_a / F_r = 1\,000 / 2\,500 = 0.4 > e$

$$X = 0.56$$

$Y = 1.67$  (the value of  $Y$  is obtained by linear interpolation)

Therefore, the dynamic equivalent load  $P$  is

$$\begin{aligned} P &= XF_r + YF_a \\ &= 0.56 \times 2\,500 + 1.67 \times 1\,000 \\ &= 3\,070\text{ N}, \{313\text{kgf}\} \end{aligned}$$

$$\frac{C_r}{P} = \frac{29\,100}{3\,070} = 9.48$$

$$f_h = f_n \frac{C_r}{P} = 0.333 \times \frac{29\,100}{3\,070} = 3.16$$

This value of  $f_h$  corresponds approximately to 15 800 hours for ball bearings.

(Example 4)

Select a spherical roller bearing of series 231 satisfying the following conditions:

Radial load  $F_r = 45\,000\text{ N}$ , {4 950kgf}

Axial load  $F_a = 8\,000\text{ N}$ , {816kgf}

Speed  $n = 500\text{rpm}$

Basic rating life  $L_h \geq 30\,000\text{h}$

The value of the fatigue life factor  $f_h$ , which makes  $L_h \geq 30\,000\text{h}$  is bigger than 3.45 from Fig. 5.4 (Page A26).

The dynamic equivalent load  $P$  of spherical roller bearings is given by:

when  $F_a / F_r \leq e$

$$P = XF_r + YX_a = F_r + Y_3 F_a$$

when  $F_a / F_r > e$

$$\begin{aligned} P &= XF_r + YF_a = 0.67 F_r + Y_2 F_a \\ F_a / F_r &= 8\,000 / 45\,000 = 0.18 \end{aligned}$$

We can see in the bearing table that the value of  $e$  is about 0.3 and that of  $Y_3$  is about 2.2 for bearings of series 231:

$$\begin{aligned} \text{Therefore, } P &= XF_r + YF_a = F_r + Y_3 F_a \\ &= 45\,000 + 2.2 \times 8\,000 \\ &= 62\,600\text{ N}, \{6\,380\text{kgf}\} \end{aligned}$$

From the fatigue life factor  $f_h$ , the basic load rating can be obtained as follows:

$$f_h = f_n \frac{C_r}{P} = 0.444 \times \frac{C_r}{62\,600} \geq 3.45$$

consequently,  $C_r \geq 490\,000\text{ N}$ , {50 000kgf}

Among spherical roller bearings of series 231 satisfying this value of  $C_r$ , the smallest is **23126CE4** ( $C_r = 505\,000\text{ N}$ , {51 500kgf})

Once the bearing is determined, substitute the value of  $Y_3$  in the equation and obtain the value of  $P$ .

$$\begin{aligned} P &= F_r + Y_3 F_a = 45\,000 + 2.4 \times 8\,000 \\ &= 64\,200\text{ N}, \{6\,550\text{kgf}\} \end{aligned}$$

$$\begin{aligned} L_h &= 500 \left( f_n \frac{C_r}{P} \right)^{\frac{10}{3}} \\ &= 500 \left( 0.444 \times \frac{505\,000}{64\,200} \right)^{\frac{10}{3}} \\ &= 500 \times 3.49^{\frac{10}{3}} \approx 32\,000\text{h} \end{aligned}$$

(Example 5)

Assume that tapered roller bearings **HR30305DJ** and **HR30206J** are used in a back-to-back arrangement as shown in Fig. 5.14, and the distance between the cup back faces is 50mm.

Calculate the basic rating life of each bearing when beside the radial load  $F_r = 5\,500\text{ N}$ , {561kgf}, axial load  $F_{ae} = 2\,000\text{ N}$ , {204kgf} are applied to **HR30305DJ** as shown in Fig. 5.14. The speed is 600rpm.

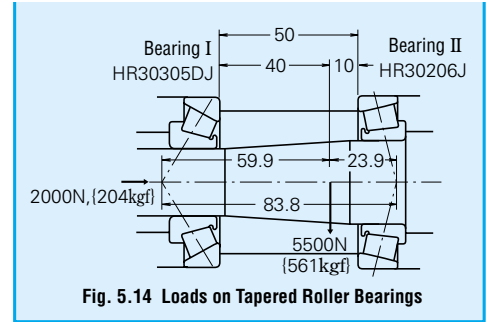

Fig. 5.14 Loads on Tapered Roller Bearings

To distribute the radial load  $F_r$  on bearings I and II, the effective load centers must be located for tapered roller bearings. Obtain the effective load center  $a$  for bearings I and II from the bearing table, then obtain the relative position of the radial load  $F_r$  and effective load centers. The result will be as shown in Fig. 5.14. Consequently, the radial load applied on bearings I (**HR30305DJ**) and II (**HR30206J**) can be obtained from the following equations:

$$F_{rI} = 5\,500 \times \frac{23.9}{83.8} = 1\,569\text{ N}, \{160\text{kgf}\}$$

$$F_{rII} = 5\,500 \times \frac{59.9}{83.8} = 3\,931\text{ N}, \{401\text{kgf}\}$$

From the data in the bearing table, the following values are obtained;

Bearings	Basic dynamic load rating $C_r$ (N) {kgf}	Axial load factor $Y_1$	Constant $e$
Bearing I ( <b>HR30305DJ</b> )	38 000 {3 900}	$Y_1 = 0.73$	0.83
Bearing II ( <b>HR30206J</b> )	43 000 {4 400}	$Y_1 = 1.6$	0.38

When radial loads are applied on tapered roller bearings, an axial load component is produced, which must be considered to obtain the dynamic equivalent radial load (Refer to Paragraph 5.4.2, Page A31).



$$F_{ae} + \frac{0.6}{Y_{II}} F_{rII} = 2\,000 + \frac{0.6}{1.6} \times 3\,931 = 3\,474\text{N}, \{354\text{kgf}\}$$

$$\frac{0.6}{Y_I} F_{rI} = \frac{0.6}{0.73} \times 1\,569 = 1\,290\text{N}, \{132\text{kgf}\}$$

Therefore, with this bearing arrangement, the axial load

$F_{ae} + \frac{0.6}{Y_{II}} F_{rII}$  is applied on bearing I but not on bearing II.

For bearing I

$$F_{rI} = 1\,569\text{N}, \{160\text{kgf}\}$$

$$F_{aI} = 3\,474\text{N}, \{354\text{kgf}\}$$

since  $F_{aI} / F_{rI} = 2.2 > e = 0.83$

the dynamic equivalent load  $P_I = XF_{rI} + Y_I F_{aI}$

$$= 0.4 \times 1\,569 + 0.73 \times 3\,474$$

$$= 3\,164\text{N}, \{323\text{kgf}\}$$

The fatigue life factor  $f_h = f_n \frac{C_r}{P_I}$

$$= \frac{0.42 \times 38\,000}{3\,164} = 5.04$$

and the rating fatigue life  $L_h = 500 \times 5.04^{\frac{10}{3}} = 109\,750\text{h}$

For bearing II

since  $F_{rII} = 3\,931\text{N}, \{401\text{kgf}\}, F_{aII} = 0$

the dynamic equivalent load

$$P_{II} = F_{rII} = 3\,931\text{N}, \{401\text{kgf}\}$$

the fatigue life factor

$$f_h = f_n \frac{C_r}{P_{II}} = \frac{0.42 \times 43\,000}{3\,931} = 4.59$$

and the rating fatigue life  $L_h = 500 \times 4.59^{\frac{10}{3}} = 80\,400\text{h}$  are obtained.

Remarks For face-to-face arrangements (DF type), please contact NSK.

In this application, heavy loads, shocks, and shaft deflection are expected; therefore, spherical roller bearings are appropriate.

The following spherical roller bearings satisfy the above size limitation (refer to Page B192)

d	D	B	Bearing No.	Basic dynamic load rating $C_r$ (N)	Constant Factor $e$	Factor $Y_3$
300	420	90	<b>23960 CAE4</b>	1 230 000	0.19	3.5
	460	118	<b>23060 CAE4</b>	1 920 000	0.24	2.8
	460	160	<b>24060 CAE4</b>	2 310 000	0.32	2.1
500	160		<b>23160 CAE4</b>	2 670 000	0.31	2.2
	200		<b>24160 CAE4</b>	3 100 000	0.38	1.8

since  $F_a / F_r = 0.20 < e$   
the dynamic equivalent load  $P$  is

$$P = F_r + Y_3 F_a$$

Judging from the fatigue life factor  $f_h$  in Table 5.1 and examples of applications (refer to Page A25), a value of  $f_h$ , between 3 and 5 seems appropriate.

$$f_h = f_n \frac{C_r}{P} = \frac{0.444 C_r}{F_r + Y_3 F_a} = 3 \sim 5$$

Assuming that  $Y_3 = 2.1$ , then the necessary basic load rating  $C_r$  can be obtained

$$C_r = \frac{(F_r + Y_3 F_a) \times (3 \sim 5)}{0.444} = \frac{(245\,000 + 2.1 \times 49\,000) \times (3 \sim 5)}{0.444} = 2\,350\,000 \sim 3\,900\,000\text{N}, \{240\,000 \sim 400\,000\text{kgf}\}$$

The bearings which satisfy this range are **23160CAE4**, and **24160CAE4**.

## 6. LIMITING SPEED

The speed of rolling bearings is subject to certain limits. When bearings are operating, the higher the speed, the higher the bearing temperature due to friction. The limiting speed is the empirically obtained value for the maximum speed at which bearings can be continuously operated without failing from seizure or generation of excessive heat. Consequently, the limiting speed of bearings varies depending on such factors as bearing type and size, cage form and material, load, lubricating method, and heat dissipating method including the design of the bearing's surroundings.

The limiting speeds for bearings lubricated by grease and oil are listed in the bearing tables. The limiting speeds in the tables are applicable to bearings of standard design and subjected to normal loads, i. e.  $C/P \geq 12$  and  $F_a/F_r \leq 0.2$  approximately. The limiting speeds for oil lubrication listed in the bearing tables are for conventional oil bath lubrication.

Some types of lubricants are not suitable for high speed, even though they may be markedly superior in other respects. When speeds are more than 70 percent of the listed limiting speed, it is necessary to select an oil or grease which has good high speed characteristics.

(Refer to)

Table 12.2 Grease Properties (Pages A110 and 111)

Table 12.5 Example of Selection of Lubricant for Bearing Operating Conditions (Page A113)

Table 15.8 Brands and Properties of Lubricating Grease (Pages A138 to A141)

### 6.1 Correction of Limiting Speed

When the bearing load  $P$  exceeds 8% of the basic load rating  $C$ , or when the axial load  $F_a$  exceeds 20% of the radial load  $F_r$ , the limiting speed must be corrected by multiplying the limiting speed found in the bearing tables by the correction factor shown in Figs. 6.1 and 6.2.

When the required speed exceeds the limiting speed of the desired bearing; then the accuracy grade, internal clearance, cage type and material, lubrication, etc., must be carefully studied in order to select a bearing capable of the required speed. In such a case, forced-circulation oil lubrication, jet lubrication, oil mist lubrication, or oil-air lubrication must be used.

If all these conditions are considered. The maximum permissible speed may be corrected by multiplying the limiting speed found in the bearing tables by the correction factor shown in Table 6.1. It is recommended that NSK be consulted regarding high speed applications.

### 6.2 Limiting Speed for Rubber Contact Seals for Ball Bearings

The maximum permissible speed for contact rubber sealed bearings (DDU type) is determined mainly by the sliding surface speed of the inner circumference of the seal. Values for the limiting speed are listed in the bearing tables.

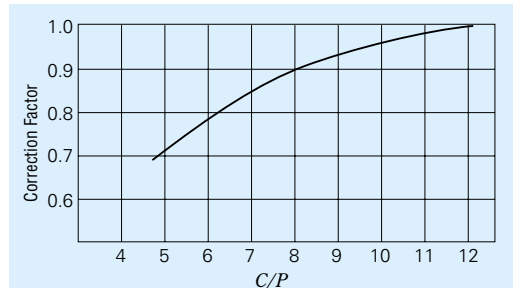

Fig. 6.1 Limiting Speed Correction Factor Variation with Load Ratio

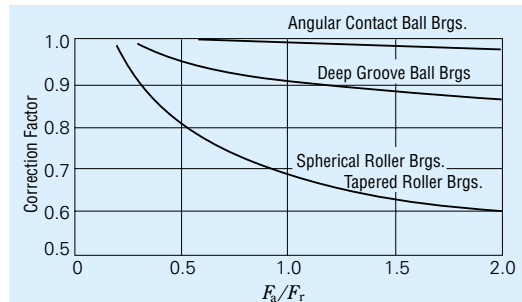

Fig. 6.2 Limiting Speed Correction Factor for Combined Radial and Axial Loads

Table 6.1 Limiting Speed Correction Factor for High-Speed Applications

Bearing Types	Correction Factor
Cylindrical Roller Brgs.(single row)	2
Needle Roller Brgs.(except broad width)	2
Tapered Roller Brgs.	2
Spherical Roller Brgs.	1.5
Deep Groove Ball Brgs.	2.5
Angular Contact Ball Brgs.(except matched bearings)	1.5

**(Example 6)**  
Select a bearing for a speed reducer under the following conditions:  
Operating conditions  
Radial load  $F_r = 245\,000\text{ N}, \{25\,000\text{kgf}\}$   
Axial load  $F_a = 49\,000\text{N}, \{5\,000\text{kgf}\}$   
Speed  $n = 500\text{rpm}$   
Size limitation  
Shaft diameter: 300mm  
Bore of housing: Less than 500mm

# 7. BOUNDARY DIMENSIONS AND IDENTIFYING NUMBERS FOR BEARINGS

## 7.1 Boundary Dimensions and Dimensions of Snap Ring Grooves

### 7.1.1 Boundary Dimensions

The boundary dimensions of rolling bearings, which are shown in Figs.7.1 through 7.5, are the dimensions that define their external geometry. They include bore diameter  $d$ , outside diameter  $D$ , width  $B$ , bearing width (or height)  $T$ , chamfer dimension  $r$ , etc. It is necessary to know all of these dimensions when mounting a bearing on a shaft and in a housing. These boundary dimensions have been internationally standardized (ISO15) and adopted by JIS B 1512 (Boundary Dimensions of Rolling Bearings).

The boundary dimensions and dimension series of radial bearings, tapered roller bearings, and thrust bearings are listed in Table 7.1 to 7.3 (Pages A40 to A49).

In these boundary dimension tables, for each bore number, which prescribes the bore diameter, other boundary dimensions are listed for each diameter series and dimension series. A very large number of series are possible; however, not all of them are commercially available so more can be added in the future. Across the top of each bearing table (7.1 to 7.3), representative bearing types and series symbols are shown (refer to Table 7.5, Bearing Series Symbols, Page A55).

The relative cross-sectional dimensions of radial bearings (except tapered roller bearings) and thrust bearings for the various series classifications are shown in Figs. 7.6 and 7.7 respectively.

### 7.1.2 Dimensions of Snap Ring Grooves and Locating Snap Rings

The dimensions of Snap ring grooves in the outer surfaces of bearings are specified by ISO 464. Also, the dimensions and accuracy of the locating snap rings themselves are specified by ISO 464. The dimensions of snap ring grooves and locating snap ring for bearings of diameter series 8, 9, 0, 2, 3, and 4, are shown in Table 7.4 (Pages A50 to A53).

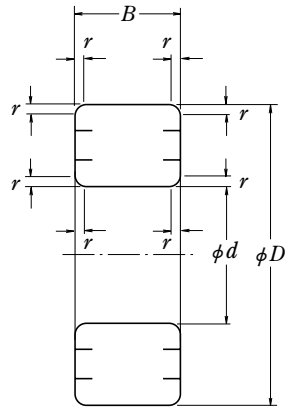

Fig. 7.1 Boundary Dimensions of Radial Ball and Roller Bearings

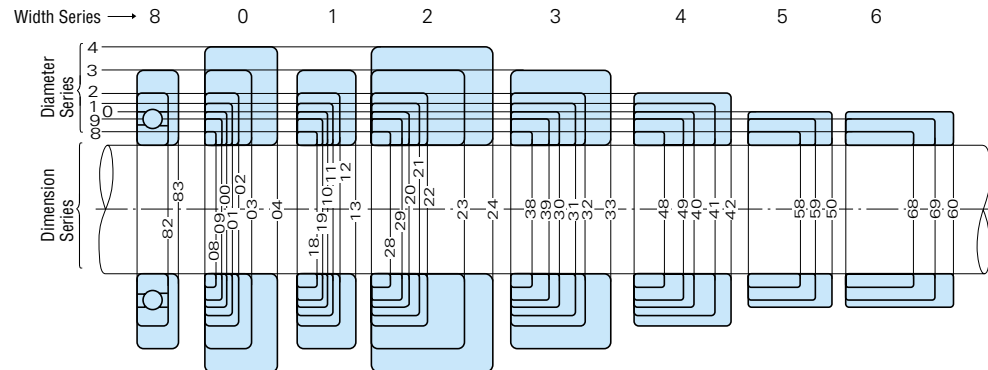

Fig. 7.6 Comparison of Cross Sections of Radial Bearings (except Tapered Roller Bearings) for various Dimensional Series

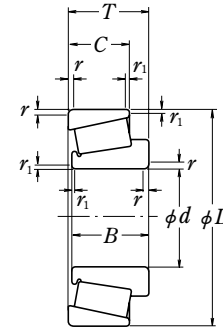

Fig. 7.2 Tapered Roller Bearings

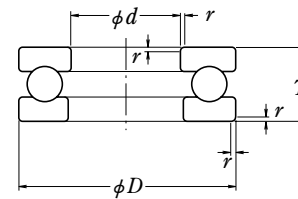

Fig. 7.3 Single-Direction Thrust Ball Bearings

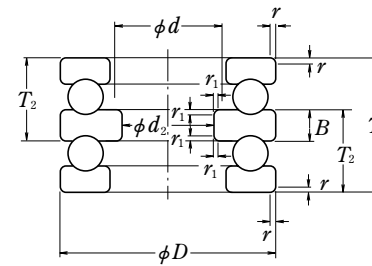

Fig. 7.4 Double-Direction Thrust Ball Bearings

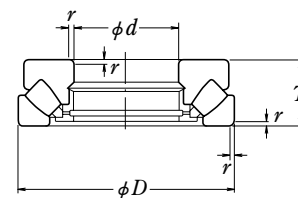

Fig. 7.5 Spherical Thrust Roller Bearings

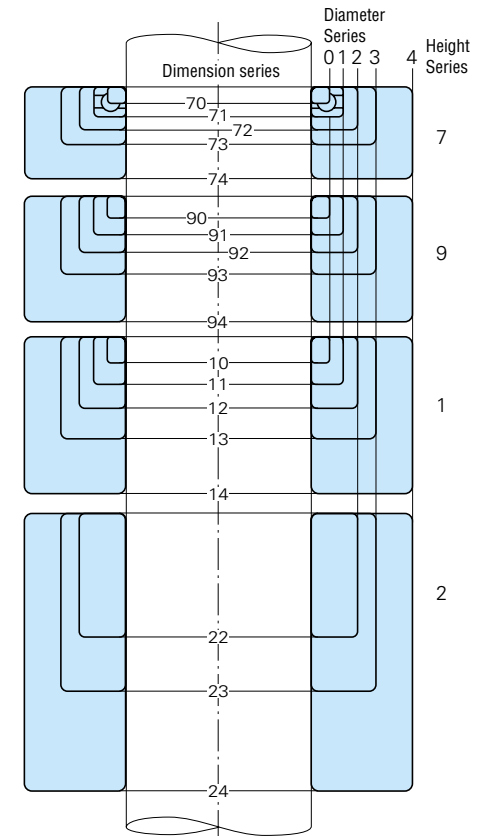

Fig. 7.7 Comparison of Cross Sections of Thrust Bearings (except Diameter Series 5) for Various Dimension Series









Table 7. 3 Boundary Dimensions of

Thrust Ball Brgs.		511										512					522				
Spherical Thrust Roller Brgs.												292									
Bore Number	d	Diameter Series 0					Diameter Series 1					Diameter Series 2									
		Dimension Series			r (min)	Dimension Series			r (min)	Dimension Series					r (min)	r <sub>1</sub> (min)					
		70	90	10		71	91	11		72	92	12	22	22							
		T			T			T					Central Washer								
D	T			D	T			D	T					d <sub>2</sub>	B						
4	4	12	4	—	6	0.3	—	—	—	—	16	6	—	8	—	—	—	0.3	—		
6	6	16	5	—	7	0.3	—	—	—	—	20	6	—	9	—	—	—	0.3	—		
8	8	18	5	—	7	0.3	—	—	—	—	22	6	—	9	—	—	—	0.3	—		
00	10	20	5	—	7	0.3	24	6	—	9	0.3	26	7	—	11	—	—	0.6	—		
01	12	22	5	—	7	0.3	26	6	—	9	0.3	28	7	—	11	—	—	0.6	—		
02	15	26	5	—	7	0.3	28	6	—	9	0.3	32	8	—	12	22	10	5	0.6	0.3	
03	17	28	5	—	7	0.3	30	6	—	9	0.3	35	8	—	12	—	—	0.6	—		
04	20	32	6	—	8	0.3	35	7	—	10	0.3	40	9	—	14	26	15	6	0.6	0.3	
05	25	37	6	—	8	0.3	42	8	—	11	0.6	47	10	—	15	28	20	7	0.6	0.3	
06	30	42	6	—	8	0.3	47	8	—	11	0.6	52	10	—	16	29	25	7	0.6	0.3	
07	35	47	6	—	8	0.3	52	8	—	12	0.6	62	12	—	18	34	30	8	1	0.3	
08	40	52	6	—	9	0.3	60	9	—	13	0.6	68	13	—	19	36	30	9	1	0.6	
09	45	60	7	—	10	0.3	65	9	—	14	0.6	73	13	—	20	37	35	9	1	0.6	
10	50	65	7	—	10	0.3	70	9	—	14	0.6	78	13	—	22	39	40	9	1	0.6	
11	55	70	7	—	10	0.3	78	10	—	16	0.6	90	16	21	25	45	45	10	1	0.6	
12	60	75	7	—	10	0.3	85	11	—	17	1	95	16	21	26	46	50	10	1	0.6	
13	65	80	7	—	10	0.3	90	11	—	18	1	100	16	21	27	47	55	10	1	0.6	
14	70	85	7	—	10	0.3	95	11	—	18	1	105	16	21	27	47	55	10	1	1	
15	75	90	7	—	10	0.3	100	11	—	19	1	110	16	21	27	47	60	10	1	1	
16	80	95	7	—	10	0.3	105	11	—	19	1	115	16	21	28	48	65	10	1	1	
17	85	100	7	—	10	0.3	110	11	—	19	1	125	18	24	31	55	70	12	1	1	
18	90	105	7	—	10	0.3	120	14	—	22	1	135	20	27	35	62	75	14	1.1	1	
20	100	120	9	—	14	0.6	135	16	21	25	1	150	23	30	38	67	85	15	1.1	1	
22	110	130	9	—	14	0.6	145	16	21	25	1	160	23	30	38	67	95	15	1.1	1	
24	120	140	9	—	14	0.6	155	18	24	31	1	170	23	30	39	68	100	15	1.1	1.1	
26	130	150	9	—	14	0.6	170	18	24	30	1	190	27	36	45	80	110	18	1.5	1.1	
28	140	160	9	—	14	0.6	180	18	24	31	1	200	27	36	46	81	120	18	1.5	1.1	
30	150	170	9	—	14	0.6	190	18	24	31	1	215	29	39	50	89	130	20	1.5	1.1	
32	160	180	9	—	14	0.6	200	18	24	31	1	225	29	39	51	90	140	20	1.5	1.1	
34	170	190	9	—	14	0.6	215	20	27	34	1.1	240	32	42	55	97	150	21	1.5	1.1	
36	180	200	9	—	14	0.6	225	20	27	34	1.1	250	32	42	56	98	150	21	1.5	2	
38	190	215	11	—	17	1	240	23	30	37	1.1	270	36	48	62	109	160	24	2	2	
40	200	225	11	—	17	1	250	23	30	37	1.1	280	36	48	62	109	170	24	2	2	
44	220	250	14	—	22	1	270	23	30	37	1.1	300	36	48	63	110	190	24	2	2	
48	240	270	14	—	22	1	300	27	36	45	1.5	340	45	60	78	—	—	—	2.1	—	
52	260	290	14	—	22	1	320	27	36	45	1.5	360	45	60	79	—	—	—	2.1	—	
56	280	310	14	—	22	1	350	32	42	53	1.5	380	45	60	80	—	—	—	2.1	—	
60	300	340	18	24	30	1	380	36	48	62	2	420	54	73	95	—	—	—	3	—	
64	320	360	18	24	30	1	400	36	48	63	2	440	54	73	95	—	—	—	3	—	

Remarks 1. Dimension Series 22, 23, and 24 are double direction bearings.  
2. The maximum permissible outside diameter of shaft and central washers and minimum permissible bore diameter of housing washers are omitted here. (Refer to the bearing tables for Thrust Bearings).

Thrust Bearings (Flat Seats) — 1 —

Units: mm

Spherical Thrust Roller Brgs.		513										523					514					524					Thrust Ball Brgs.	
Spherical Thrust Roller Brgs.		293															294										Spherical Thrust Roller Brgs.	
Bore Number	d	Diameter Series 3										Diameter Series 4										Diameter Series 5					Bore Number	
		Dimension Series					r (min)	r <sub>1</sub> (min)	Dimension Series					r (min)	r <sub>1</sub> (min)	Dimension Series		r (min)										
		73	93	13	23	23			74	94	14	24	24			95												
		T					Central Washer		T					Central Washer		T												
D	T					d <sub>2</sub>	B	D	T					d <sub>2</sub>	B	D	T	d										
20	7	—	11	—	—	—	0.6	—	—	—	—	—	—	—	—	—	—	—	—	—	—	—	—	4	4			
24	8	—	12	—	—	—	0.6	—	—	—	—	—	—	—	—	—	—	—	—	—	—	—	—	6	6			
26	8	—	12	—	—	—	0.6	—	—	—	—	—	—	—	—	—	—	—	—	—	—	—	—	8	8			
30	9	—	14	—	—	—	0.6	—	—	—	—	—	—	—	—	—	—	—	—	—	—	—	—	10	00			
32	9	—	14	—	—	—	0.6	—	—	—	—	—	—	—	—	—	—	—	—	—	—	—	—	12	01			
37	10	—	15	—	—	—	0.6	—	—	—	—	—	—	—	—	—	—	—	—	—	—	—	—	15	02			
40	10	—	16	—	—	—	0.6	—	—	—	—	—	—	—	—	—	—	—	—	—	—	—	—	17	03			
47	12	—	18	—	—	—	1	—	—	—	—	—	—	—	—	—	—	—	—	—	—	—	—	20	04			
52	12	—	18	34	20	8	1	0.3	60	16	21	24	45	15	11	1	0.6	52	21	1	1	17	03	25	05			
60	14	—	21	38	25	9	1	0.3	70	18	24	28	52	20	12	1	0.6	85	34	1.1	1	30	06	35	07			
68	15	—	24	44	30	10	1	0.3	80	20	27	32	59	25	14	1.1	0.6	100	39	1.1	1	35	07	40	08			
78	17	22	26	49	30	12	1	0.6	90	23	30	36	65	30	15	1.1	0.6	110	42	1.5	1	40	08	45	09			
85	18	24	28	52	35	12	1	0.6	100	25	34	39	72	35	17	1.1	0.6	120	45	2	1	45	09	50	10			
95	20	27	31	58	40	14	1.1	0.6	110	27	36	43	78	40	18	1.5	0.6	135	51	2	1	50	10	55	11			
105	23	30	35	64	45	15	1.1	0.6	120	29	39	48	87	45	20	1.5	0.6	150	58	2.1	1	55	11	60	12			
110	23	30	35	64	50	15	1.1	0.6	130	32	42	51	93	50	21	1.5	0.6	160	60	2.1	1	60	12	65	13			
115	23	30	36	65	55	15	1.1	0.6	140	34	45	56	101	50	23	2	1	170	63	2.1	1	65	13	70	14			
125	25	34	40	72	55	16	1.1	1	150	36	48	60	107	55	24	2	1	180	67	3	1	70	14	75	15			
135	27	36	44	79	60	18	1.5	1	160	38	51	65	115	60	26	2	1	190	69	3	1	75	15	80	16			
140	27	36	44	79	65	18	1.5	1	170	41	54	68	120	65	27	2.1	1	200	73	3	1	80	16	85	17			
150	29	39	49	87	70	19	1.5	1	180	42	58	72	128	65	29	2.1	1.1	215	78	4	1	85	17	90	18			
155	29	39	50	88	75	19	1.5	1	190	45	60	77	135	70	30	2.1	1.1	225	82	4	1	90	18	95	19			
170	32	42	55	97	85	21	1.5	1	210	50	67	85	150	80	33	3	1.1	250	90	4	1	100	20	100	20			
190	36	48	63	110	95	24	2	1	230	54	73	95	166	90	37	3	1.1	270	95	5	1	110	22	110	22			
210	41	54	70	123	100	27	2.1	1.1	250	58	78	102	177	95	40	4	1.5	300	109	5	1	120	24	120	24			
225	42	58	75	130	110	30	2.1	1.1	270	63	85	110	192	100	42	4	2	320	115	5	1	130	26	130	26			
240	45	60	80	140	120	31	2.1	1.1	280	63	85																	

Table 7. 3 Boundary Dimensions of

Thrust Ball Brgs.								511						512		522								
Spherical Thrust Roller Brgs.										292														
Bore Number	d	Diameter Series 0					Diameter Series 1					Diameter Series 2								d	Bore Number			
		Dimension Series			r (min)	Dimension Series			r (min)	Dimension Series								r (min)	r <sub>1</sub> (min)					
		D	70	90		10	D	71		91	11	D	72	92	12	22	22					r (min)	r <sub>1</sub> (min)	
			T			T				T			Central Washer											
												d <sub>2</sub> B												
68	340	380	18	24	30	1	420	36	48	64	2	460	54	73	96	—	—	—	3	—				
72	360	400	18	24	30	1	440	36	48	65	2	500	63	85	110	—	—	—	4	—				
76	380	420	18	24	30	1	460	36	48	65	2	520	63	85	112	—	—	—	4	—				
80	400	440	18	24	30	1	480	36	48	65	2	540	63	85	112	—	—	—	4	—				
84	420	460	18	24	30	1	500	36	48	65	2	580	73	95	130	—	—	—	5	—				
88	440	480	18	24	30	1	540	45	60	80	2.1	600	73	95	130	—	—	—	5	—				
92	460	500	18	24	30	1	560	45	60	80	2.1	620	73	95	130	—	—	—	5	—				
96	480	520	18	24	30	1	580	45	60	80	2.1	650	78	103	135	—	—	—	5	—				
/500	500	540	18	24	30	1	600	45	60	80	2.1	670	78	103	135	—	—	—	5	—				
/530	530	580	23	30	38	1.1	640	50	67	85	3	710	82	109	140	—	—	—	5	—				
/560	560	610	23	30	38	1.1	670	50	67	85	3	750	85	115	150	—	—	—	5	—				
/600	600	650	23	30	38	1.1	710	50	67	85	3	800	90	122	160	—	—	—	5	—				
/630	630	680	23	30	38	1.1	750	54	73	95	3	850	100	132	175	—	—	—	6	—				
/670	670	730	27	36	45	1.5	800	58	78	105	4	900	103	140	180	—	—	—	6	—				
/710	710	780	32	42	53	1.5	850	63	85	112	4	950	109	145	190	—	—	—	6	—				
/750	750	820	32	42	53	1.5	900	67	90	120	4	1000	112	150	195	—	—	—	6	—				
/800	800	870	32	42	53	1.5	950	67	90	120	4	1060	118	155	205	—	—	—	7.5	—				
/850	850	920	32	42	53	1.5	1000	67	90	120	4	1120	122	160	212	—	—	—	7.5	—				
/900	900	980	36	48	63	2	1060	73	95	130	5	1180	125	170	220	—	—	—	7.5	—				
/950	950	1030	36	48	63	2	1120	78	103	135	5	1250	136	180	236	—	—	—	7.5	—				
/1000	1000	1090	41	54	70	2.1	1180	82	109	140	5	1320	145	190	250	—	—	—	9.5	—				
/1060	1060	1150	41	54	70	2.1	1250	85	115	150	5	1400	155	206	265	—	—	—	9.5	—				
/1120	1120	1220	45	60	80	2.1	1320	90	122	160	5	1460	—	206	—	—	—	—	9.5	—				
/1180	1180	1280	45	60	80	2.1	1400	100	132	175	6	1520	—	206	—	—	—	—	9.5	—				
/1250	1250	1360	50	67	85	3	1460	—	175	5	1610	—	216	—	—	—	—	—	9.5	—				
/1320	1320	1440	—	—	95	3	1540	—	175	6	1700	—	228	—	—	—	—	—	9.5	—				
/1400	1400	1520	—	—	95	3	1630	—	180	6	1790	—	234	—	—	—	—	—	12	—				
/1500	1500	1630	—	—	105	4	1750	—	195	6	1920	—	252	—	—	—	—	—	12	—				
/1600	1600	1730	—	—	105	4	1850	—	195	6	2040	—	264	—	—	—	—	—	15	—				
/1700	1700	1840	—	—	112	4	1970	—	212	7.5	2160	—	276	—	—	—	—	—	15	—				
/1800	1800	1950	—	—	120	4	2080	—	220	7.5	2280	—	288	—	—	—	—	—	15	—				
/1900	1900	2060	—	—	130	5	2180	—	220	7.5	—	—	—	—	—	—	—	—	—	—				
/2000	2000	2160	—	—	130	5	2300	—	236	7.5	—	—	—	—	—	—	—	—	—	—				
/2120	2120	2300	—	—	140	5	2430	—	243	7.5	—	—	—	—	—	—	—	—	—	—				
/2240	2240	2430	—	—	150	5	2570	—	258	9.5	—	—	—	—	—	—	—	—	—	—				
/2360	2360	2550	—	—	150	5	2700	—	265	9.5	—	—	—	—	—	—	—	—	—	—				
/2500	2500	2700	—	—	160	5	2850	—	272	9.5	—	—	—	—	—	—	—	—	—	—				

Remarks 1. Dimension Series 22, 23, and 24 are double direction bearings.  
 2. The maximum permissible outside diameter of shaft and central washers and minimum permissible bore diameter of housing washers are omitted here. (Refer to the bearings tables for Thrust Bearings).

Thrust Bearings (Flat Seats) — 2 —

Units: mm

				513		523						514		524				Thrust Ball Brgs.					
				293						294								Spherical Thrust Roller Brgs.					
Bore Number	d	Diameter Series 3								Diameter Series 4								Diameter Series 5		d	Bore Number		
		Dimension Series					r (min)	r <sub>1</sub> (min)	Dimension Series					r (min)	r <sub>1</sub> (min)	D	r (min)						
		D	73	93	13	23			23	D	74	94	14					24	24			D	95
			T						Central Washer		T							Central Washer					
				d <sub>2</sub> B						d <sub>2</sub> B													
540	90	122	160	—	—	—	5	—	620	125	170	220	—	—	—	7.5	—	750	243	12	340	68	
560	90	122	160	—	—	—	5	—	640	125	170	220	—	—	—	7.5	—	780	250	12	360	72	
600	100	132	175	—	—	—	6	—	670	132	175	224	—	—	—	7.5	—	820	265	12	380	76	
620	100	132	175	—	—	—	6	—	710	140	185	243	—	—	—	7.5	—	850	272	12	400	80	
650	103	140	180	—	—	—	6	—	730	140	185	243	—	—	—	7.5	—	900	290	15	420	84	
680	109	145	190	—	—	—	6	—	780	155	206	265	—	—	—	9.5	—	950	308	15	440	88	
710	112	150	195	—	—	—	6	—	800	155	206	265	—	—	—	9.5	—	980	315	15	460	92	
730	112	150	195	—	—	—	6	—	850	165	224	290	—	—	—	9.5	—	1000	315	15	480	96	
750	112	150	195	—	—	—	6	—	870	165	224	290	—	—	—	9.5	—	1060	335	15	500	/500	
800	122	160	212	—	—	—	7.5	—	920	175	236	308	—	—	—	9.5	—	1090	335	15	530	/530	
850	132	175	224	—	—	—	7.5	—	980	190	250	335	—	—	—	12	—	1150	355	15	560	/560	
900	136	180	236	—	—	—	7.5	—	1030	195	258	335	—	—	—	12	—	1220	375	15	600	/600	
950	145	190	250	—	—	—	9.5	—	1090	206	280	365	—	—	—	12	—	1280	388	15	630	/630	
1000	150	200	258	—	—	—	9.5	—	1150	218	290	375	—	—	—	15	—	1320	388	15	670	/670	
1060	160	212	272	—	—	—	9.5	—	1220	230	308	400	—	—	—	15	—	1400	412	15	710	/710	
1120	165	224	290	—	—	—	9.5	—	1280	236	315	412	—	—	—	15	—	—	—	—	750	/750	
1180	170	230	300	—	—	—	9.5	—	1360	250	335	438	—	—	—	15	—	—	—	—	800	/800	
1250	180	243	315	—	—	—	12	—	1440	—	354	—	—	—	—	15	—	—	—	—	850	/850	
1320	190	250	335	—	—	—	12	—	1520	—	372	—	—	—	—	15	—	—	—	—	900	/900	
1400	200	272	355	—	—	—	12	—	1600	—	390	—	—	—	—	15	—	—	—	—	950	/950	
1460	—	276	—	—	—	—	12	—	1670	—	402	—	—	—	—	15	—	—	—	—	1000	/1000	
1540																							

Table 7. 4 Dimensions of Snap Ring Grooves and Locating Snap Rings — (1)  
Bearings of Dimension Series 18 and 19

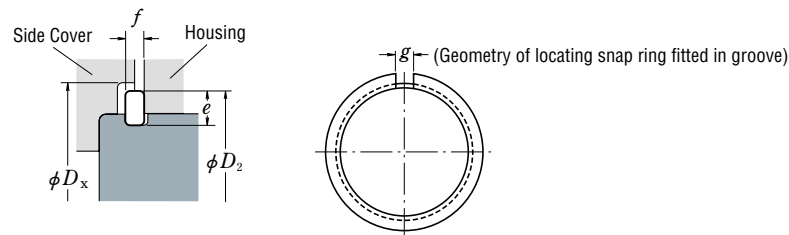
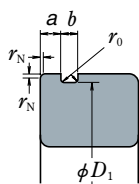

Units: mm

Applicable Bearings		Snap Ring Groove									
<i>d</i>		<i>D</i>	Snap Ring Groove Diameter <i>D</i> <sub>1</sub>		Snap Ring Groove Position <i>a</i>				Snap Ring Groove Width <i>b</i>		Radius of Bottom Corners <i>r</i> <sub>0</sub>
					Bearing Dimension Series						
					18		19				
Dimension Series				max	min	max	min	max	min	max	
18	19	max	min	max	min	max	min	max	min	max	
—	10	22	20.8	20.5	—	—	1.05	0.9	1.05	0.8	0.2
—	12	24	22.8	22.5	—	—	1.05	0.9	1.05	0.8	0.2
—	15	28	26.7	26.4	—	—	1.3	1.15	1.2	0.95	0.25
—	17	30	28.7	28.4	—	—	1.3	1.15	1.2	0.95	0.25
20	—	32	30.7	30.4	1.3	1.15	—	—	1.2	0.95	0.25
22	—	34	32.7	32.4	1.3	1.15	—	—	1.2	0.95	0.25
25	20	37	35.7	35.4	1.3	1.15	1.7	1.55	1.2	0.95	0.25
—	22	39	37.7	37.4	—	—	1.7	1.55	1.2	0.95	0.25
28	—	40	38.7	38.4	1.3	1.15	—	—	1.2	0.95	0.25
30	25	42	40.7	40.4	1.3	1.15	1.7	1.55	1.2	0.95	0.25
32	—	44	42.7	42.4	1.3	1.15	—	—	1.2	0.95	0.25
—	28	45	43.7	43.4	—	—	1.7	1.55	1.2	0.95	0.25
35	30	47	45.7	45.4	1.3	1.15	1.7	1.55	1.2	0.95	0.25
40	32	52	50.7	50.4	1.3	1.15	1.7	1.55	1.2	0.95	0.25
—	35	55	53.7	53.4	—	—	1.7	1.55	1.2	0.95	0.25
45	—	58	56.7	56.4	1.3	1.15	—	—	1.2	0.95	0.25
—	40	62	60.7	60.3	—	—	1.7	1.55	1.2	0.95	0.25
50	—	65	63.7	63.3	1.3	1.15	—	—	1.2	0.95	0.25
—	45	68	66.7	66.3	—	—	1.7	1.55	1.2	0.95	0.25
55	50	72	70.7	70.3	1.7	1.55	1.7	1.55	1.2	0.95	0.25
60	—	78	76.2	75.8	1.7	1.55	—	—	1.6	1.3	0.4
—	55	80	77.9	77.5	—	—	2.1	1.9	1.6	1.3	0.4
65	60	85	82.9	82.5	1.7	1.55	2.1	1.9	1.6	1.3	0.4
70	65	90	87.9	87.5	1.7	1.55	2.1	1.9	1.6	1.3	0.4
75	—	95	92.9	92.5	1.7	1.55	—	—	1.6	1.3	0.4
80	70	100	97.9	97.5	1.7	1.55	2.5	2.3	1.6	1.3	0.4
—	75	105	102.6	102.1	—	—	2.5	2.3	1.6	1.3	0.4
85	80	110	107.6	107.1	2.1	1.9	2.5	2.3	1.6	1.3	0.4
90	—	115	112.6	112.1	2.1	1.9	—	—	1.6	1.3	0.4
95	85	120	117.6	117.1	2.1	1.9	3.3	3.1	1.6	1.3	0.4
100	90	125	122.6	122.1	2.1	1.9	3.3	3.1	1.6	1.3	0.4
105	95	130	127.6	127.1	2.1	1.9	3.3	3.1	1.6	1.3	0.4
110	100	140	137.6	137.1	2.5	2.3	3.3	3.1	2.2	1.9	0.6
—	105	145	142.6	142.1	—	—	3.3	3.1	2.2	1.9	0.6
120	110	150	147.6	147.1	2.5	2.3	3.3	3.1	2.2	1.9	0.6
130	120	165	161.8	161.3	3.3	3.1	3.7	3.5	2.2	1.9	0.6
140	—	175	171.8	171.3	3.3	3.1	—	—	2.2	1.9	0.6
—	130	180	176.8	176.3	—	—	3.7	3.5	2.2	1.9	0.6
150	140	190	186.8	186.3	3.3	3.1	3.7	3.5	2.2	1.9	0.6
160	—	200	196.8	196.3	3.3	3.1	—	—	2.2	1.9	0.6

Locating Snap Ring						Side Cover	
Locating Snap Ring Number	Cross Sectional Height		Thickness		Geometry of snap ring fitted in groove (Reference)		Stepped Bore Diameter (Reference) <i>D</i> <sub>x</sub>
	<i>e</i>		<i>f</i>		Slit Width <i>g</i>	Snap Ring Outside Diameter <i>D</i> <sub>2</sub>	
	max	min	max	min			
	max	min	max	min	approx	max	min
NR 1022	2.0	1.85	0.7	0.6	2	24.8	25.5
NR 1024	2.0	1.85	0.7	0.6	2	26.8	27.5
NR 1028	2.05	1.9	0.85	0.75	3	30.8	31.5
NR 1030	2.05	1.9	0.85	0.75	3	32.8	33.5
NR 1032	2.05	1.9	0.85	0.75	3	34.8	35.5
NR 1034	2.05	1.9	0.85	0.75	3	36.8	37.5
NR 1037	2.05	1.9	0.85	0.75	3	39.8	40.5
NR 1039	2.05	1.9	0.85	0.75	3	41.8	42.5
NR 1040	2.05	1.9	0.85	0.75	3	42.8	43.5
NR 1042	2.05	1.9	0.85	0.75	3	44.8	45.5
NR 1044	2.05	1.9	0.85	0.75	4	46.8	47.5
NR 1045	2.05	1.9	0.85	0.75	4	47.8	48.5
NR 1047	2.05	1.9	0.85	0.75	4	49.8	50.5
NR 1052	2.05	1.9	0.85	0.75	4	54.8	55.5
NR 1055	2.05	1.9	0.85	0.75	4	57.8	58.5
NR 1058	2.05	1.9	0.85	0.75	4	60.8	61.5
NR 1062	2.05	1.9	0.85	0.75	4	64.8	65.5
NR 1065	2.05	1.9	0.85	0.75	4	67.8	68.5
NR 1068	2.05	1.9	0.85	0.75	5	70.8	72
NR 1072	2.05	1.9	0.85	0.75	5	74.8	76
NR 1078	3.25	3.1	1.12	1.02	5	82.7	84
NR 1080	3.25	3.1	1.12	1.02	5	84.4	86
NR 1085	3.25	3.1	1.12	1.02	5	89.4	91
NR 1090	3.25	3.1	1.12	1.02	5	94.4	96
NR 1095	3.25	3.1	1.12	1.02	5	99.4	101
NR 1100	3.25	3.1	1.12	1.02	5	104.4	106
NR 1105	4.04	3.89	1.12	1.02	5	110.7	112
NR 1110	4.04	3.89	1.12	1.02	5	115.7	117
NR 1115	4.04	3.89	1.12	1.02	5	120.7	122
NR 1120	4.04	3.89	1.12	1.02	7	125.7	127
NR 1125	4.04	3.89	1.12	1.02	7	130.7	132
NR 1130	4.04	3.89	1.12	1.02	7	135.7	137
NR 1140	4.04	3.89	1.7	1.6	7	145.7	147
NR 1145	4.04	3.89	1.7	1.6	7	150.7	152
NR 1150	4.04	3.89	1.7	1.6	7	155.7	157
NR 1165	4.85	4.7	1.7	1.6	7	171.5	173
NR 1175	4.85	4.7	1.7	1.6	10	181.5	183
NR 1180	4.85	4.7	1.7	1.6	10	186.5	188
NR 1190	4.85	4.7	1.7	1.6	10	196.5	198
NR 1200	4.85	4.7	1.7	1.6	10	206.5	208

Remarks The minimum permissible chamfer dimensions *r*<sub>N</sub> on the snap-ring-groove side of the outer rings are as follows:

Dimension series 18 : For outside diameters of 78mm and less, use 0.3mm chamfer.

For all others exceeding 78mm, use 0.5mm chamfer.

Dimension series 19 : For outside diameters of 24mm and less, use 0.2mm chamfer.

For 47mm and less, use 0.3mm chamfer.

For all others exceeding 47mm, use 0.5mm chamfer.

Table 7. 4 Dimensions of Snap Ring Grooves and Locating Snap Rings — (2)  
Bearing of Diameter Series 0, 2, 3, and 4

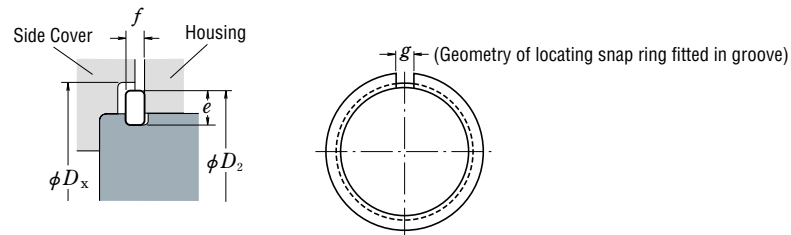
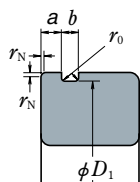

Units: mm

Applicable Bearings				Snap Ring Groove									
d Diameter Series				D	Snap Ring Groove Diameter D <sub>1</sub>		Snap Ring Groove Position a				Snap Ring Groove Width b		Radius of Bottom Corners r <sub>0</sub>
							Bearing Diameter Series						
							0		2, 3, 4				
0	2	3	4	max	min	max	min	max	min	max	min	max	
10	—	—	—	26	24.5	24.25	1.35	1.19	—	—	1.17	0.87	0.2
12	—	—	—	28	26.5	26.25	1.35	1.19	—	—	1.17	0.87	0.2
—	10	9	8	30	28.17	27.91	—	—	2.06	1.9	1.65	1.35	0.4
15	12	—	9	32	30.15	29.9	2.06	1.9	2.06	1.9	1.65	1.35	0.4
17	15	10	—	35	33.17	32.92	2.06	1.9	2.06	1.9	1.65	1.35	0.4
—	—	12	10	37	34.77	34.52	—	—	2.06	1.9	1.65	1.35	0.4
—	—	17	—	40	38.1	37.85	—	—	2.06	1.9	1.65	1.35	0.4
20	—	15	12	42	39.75	39.5	2.06	1.9	2.06	1.9	1.65	1.35	0.4
22	—	—	—	44	41.75	41.5	2.06	1.9	—	—	1.65	1.35	0.4
25	20	17	—	47	44.6	44.35	2.06	1.9	2.46	2.31	1.65	1.35	0.4
—	—	—	—	50	47.6	47.35	—	—	2.46	2.31	1.65	1.35	0.4
28	25	20	15	52	49.73	49.48	2.06	1.9	2.46	2.31	1.65	1.35	0.4
30	—	—	—	55	52.6	52.35	2.08	1.88	—	—	1.65	1.35	0.4
—	—	22	—	56	53.6	53.35	—	—	2.46	2.31	1.65	1.35	0.4
32	28	—	—	58	55.6	55.35	2.08	1.88	2.46	2.31	1.65	1.35	0.4
35	30	25	17	62	59.61	59.11	2.08	1.88	3.28	3.07	2.2	1.9	0.6
—	—	—	—	65	62.6	62.1	—	—	3.28	3.07	2.2	1.9	0.6
40	—	28	—	68	64.82	64.31	2.49	2.29	3.28	3.07	2.2	1.9	0.6
—	35	30	20	72	68.81	68.3	—	—	3.28	3.07	2.2	1.9	0.6
45	—	32	—	75	71.83	71.32	2.49	2.29	3.28	3.07	2.2	1.9	0.6
50	40	35	25	80	76.81	76.3	2.49	2.29	3.28	3.07	2.2	1.9	0.6
—	—	—	—	85	81.81	81.31	—	—	3.28	3.07	2.2	1.9	0.6
55	50	40	30	90	86.79	86.28	2.87	2.67	3.28	3.07	3	2.7	0.6
60	—	—	—	95	91.82	91.31	2.87	2.67	—	—	3	2.7	0.6
65	55	45	35	100	96.8	96.29	2.87	2.67	3.28	3.07	3	2.7	0.6
70	60	50	40	110	106.81	106.3	2.87	2.67	3.28	3.07	3	2.7	0.6
75	—	—	—	115	111.81	111.3	2.87	2.67	—	—	3	2.7	0.6
—	65	55	45	120	115.21	114.71	—	—	4.06	3.86	3.4	3.1	0.6
80	70	—	—	125	120.22	119.71	2.87	2.67	4.06	3.86	3.4	3.1	0.6
85	75	60	50	130	125.22	124.71	2.87	2.67	4.06	3.86	3.4	3.1	0.6
90	80	65	55	140	135.23	134.72	3.71	3.45	4.9	4.65	3.4	3.1	0.6
95	—	—	—	145	140.23	139.73	3.71	3.45	—	—	3.4	3.1	0.6
100	85	70	60	150	145.24	144.73	3.71	3.45	4.9	4.65	3.4	3.1	0.6
105	90	75	65	160	155.22	154.71	3.71	3.45	4.9	4.65	3.4	3.1	0.6
110	95	80	—	170	163.65	163.14	3.71	3.45	5.69	5.44	3.8	3.5	0.6
120	100	85	70	180	173.66	173.15	3.71	3.45	5.69	5.44	3.8	3.5	0.6
—	—	—	—	190	183.64	183.13	—	—	5.69	5.44	3.8	3.5	0.6
130	110	95	80	200	193.65	193.14	5.69	5.44	5.69	5.44	3.8	3.5	0.6

**Note** (1) The locating snap rings and snap ring grooves of these bearings are not specified by ISO.  
**Remarks** 1. The dimensions of these snap ring grooves are not applicable to bearings of dimension series 00, 82, and 83.  
 2. The minimum permissible chamfer dimension r<sub>N</sub> on the snap-ring side of outer rings is 0.5mm. However, for bearings of diameter series 0 having outside diameters 35mm and below, it is 0.3mm.

Locating Snap Ring							Side Cover
Locating Snap Ring Number	Cross Sectional Height		Thickness		Geometry of snap ring fitted in groove (Reference)		Stepped Bore Diameter (Reference) D <sub>X</sub>
	e		f		Slit Width g	Snap Ring Outside Diameter D <sub>2</sub>	
	max	min	max	min			
NR 26 (1)	2.06	1.91	0.84	0.74	3	28.7	29.4
NR 28 (1)	2.06	1.91	0.84	0.74	3	30.7	31.4
NR 30	3.25	3.1	1.12	1.02	3	34.7	35.5
NR 32	3.25	3.1	1.12	1.02	3	36.7	37.5
NR 35	3.25	3.1	1.12	1.02	3	39.7	40.5
NR 37	3.25	3.1	1.12	1.02	3	41.3	42
NR 40	3.25	3.1	1.12	1.02	3	44.6	45.5
NR 42	3.25	3.1	1.12	1.02	3	46.3	47
NR 44	3.25	3.1	1.12	1.02	3	48.3	49
NR 47	4.04	3.89	1.12	1.02	4	52.7	53.5
NR 50	4.04	3.89	1.12	1.02	4	55.7	56.5
NR 52	4.04	3.89	1.12	1.02	4	57.9	58.5
NR 55	4.04	3.89	1.12	1.02	4	60.7	61.5
NR 56	4.04	3.89	1.12	1.02	4	61.7	62.5
NR 58	4.04	3.89	1.12	1.02	4	63.7	64.5
NR 62	4.04	3.89	1.7	1.6	4	67.7	68.5
NR 65	4.04	3.89	1.7	1.6	4	70.7	71.5
NR 68	4.85	4.7	1.7	1.6	5	74.6	76
NR 72	4.85	4.7	1.7	1.6	5	78.6	80
NR 75	4.85	4.7	1.7	1.6	5	81.6	83
NR 80	4.85	4.7	1.7	1.6	5	86.6	88
NR 85	4.85	4.7	1.7	1.6	5	91.6	93
NR 90	4.85	4.7	2.46	2.36	5	96.5	98
NR 95	4.85	4.7	2.46	2.36	5	101.6	103
NR 100	4.85	4.7	2.46	2.36	5	106.5	108
NR 110	4.85	4.7	2.46	2.36	5	116.6	118
NR 115	4.85	4.7	2.46	2.36	5	121.6	123
NR 120	7.21	7.06	2.82	2.72	7	129.7	131.5
NR 125	7.21	7.06	2.82	2.72	7	134.7	136.5
NR 130	7.21	7.06	2.82	2.72	7	139.7	141.5
NR 140	7.21	7.06	2.82	2.72	7	149.7	152
NR 145	7.21	7.06	2.82	2.72	7	154.7	157
NR 150	7.21	7.06	2.82	2.72	7	159.7	162
NR 160	7.21	7.06	2.82	2.72	7	169.7	172
NR 170	9.6	9.45	3.1	3	10	182.9	185
NR 180	9.6	9.45	3.1	3	10	192.9	195
NR 190	9.6	9.45	3.1	3	10	202.9	205
NR 200	9.6	9.45	3.1	3	10	212.9	215

7.2 Formulation of Bearing Numbers

Bearing numbers are alphanumeric combinations that indicate the bearing type, boundary dimensions, dimensional and running accuracies, internal clearance, and other related specifications. They consist of basic numbers and supplementary symbols. The boundary dimensions of commonly used bearings mostly conform to the organizational concept of ISO, and the bearing numbers of these standard bearings are specified by JIS B 1513 (Bearing Numbers for Rolling Bearings). Due to a need for more detailed classification, NSK uses auxiliary symbols other than those specified by JIS.

Bearing numbers consist of a basic number and supplementary symbols. The basic number indicates the bearing series(type) and the width and diameter series as shown in Table 7.5. Basic numbers, supplementary symbols, and the meanings of common numbers and symbols are listed in Table 7.6 (Pages A56 and A57). The contact angle symbols and other supplementary designations are shown in successive columns from left to right in Table 7.6. For reference, some examples of bearing designations are shown here:

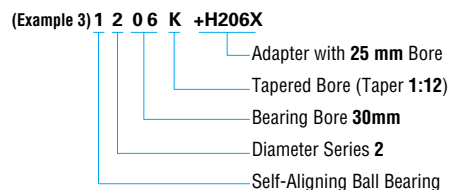
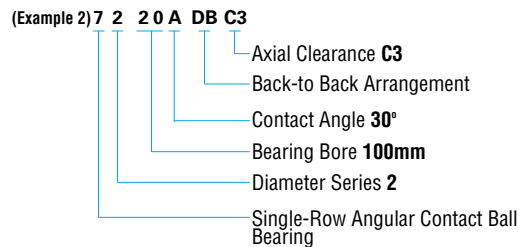
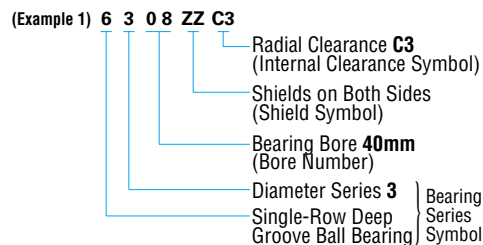
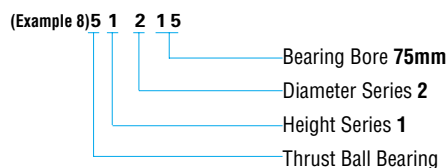
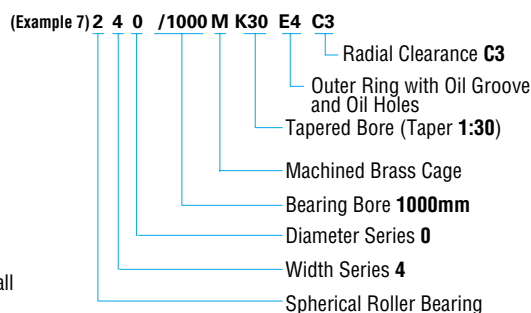
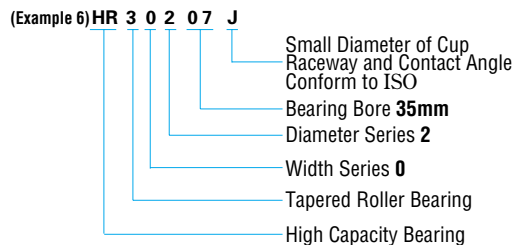
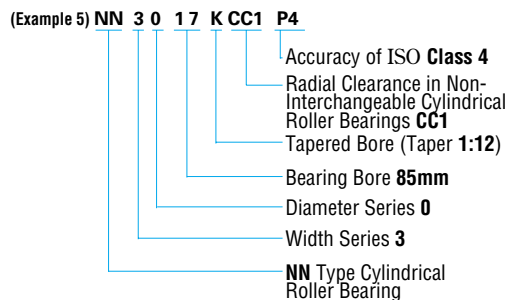
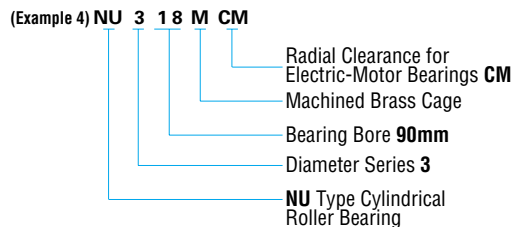

Table 7.5 Bearing Series Symbols

Bearing Type	Bearing Series Symbols	Type Symbols	Dimension Symbols			
			Width Symbols	Diameter Symbols		
Single-Row Deep Groove Ball Bearings	<b>68</b> <b>69</b> <b>60</b> <b>62</b> <b>63</b>	6 6 6 6 6	(1) (1) (1) (0) (0)	8 9 0 2 3		
Single-Row Angular Contact Ball Bearings	<b>79</b> <b>70</b> <b>72</b> <b>73</b>	7 7 7 7	(1) (1) (0) (0)	9 0 2 3		
Self-Aligning Ball Bearings	<b>12</b> <b>13</b> <b>22</b> <b>23</b>	1 1 (1) (1)	(0) (0) 2 2	2 3 2 3		
Single-Row Cylindrical Roller Bearings	<b>NU10</b> <b>NU2</b> <b>NU22</b> <b>NU3</b> <b>NU23</b> <b>NU4</b>	NU NU NU NU NU NU	1 (0) 2 (0) 2 (0)	0 2 2 3 3 4		
	<b>NJ2</b> <b>NJ22</b> <b>NJ3</b> <b>NJ23</b> <b>NJ4</b>	NJ NJ NJ NJ NJ	(0) 2 (0) 2 (0)	2 2 3 3 4		
	<b>NUP2</b> <b>NUP22</b> <b>NUP3</b> <b>NUP23</b> <b>NUP4</b>	NUP NUP NUP NUP NUP	(0) 2 (0) 2 (0)	2 2 3 3 4		
	<b>N10</b> <b>N2</b> <b>N3</b> <b>N4</b>	N N N N	1 (0) (0) (0)	0 2 3 4		
	<b>NF2</b> <b>NF3</b> <b>NF4</b>	NF NF NF	(0) (0) (0)	2 3 4		
	Tapered Roller Bearings	<b>329</b> <b>320</b> <b>330</b> <b>331</b> <b>302</b> <b>322</b> <b>332</b> <b>303</b> <b>323</b>	3 3 3 3 3 3 3 3 3	2 3 3 3 0 2 3 0 2	9 0 0 1 2 2 2 3 3	
		<b>230</b> <b>231</b> <b>222</b> <b>232</b> <b>213</b> (1) <b>223</b>	2 2 2 2 2 2	3 3 2 3 0 2	0 1 2 2 3 3	
		Spherical Roller Bearings	<b>511</b> <b>512</b> <b>513</b> <b>514</b>	5 5 5 5	1 1 1 1	1 2 3 4
			<b>522</b> <b>523</b> <b>524</b>	5 5 5	2 2 2	2 3 4
			Thrust Ball Bearings with Flat Seats	<b>292</b> <b>293</b> <b>294</b>	2 2 2	9 9 9

Note (1) Bearing Series Symbol 213 should logically be 203, but customarily it is numbered 213.  
Remarks Numbers in ( ) in the column of width symbols are usually omitted from the bearing number.

Table 7.6 Formulation of

Basic Numbers																					
Bearing Series Symbols <sup>(1)</sup>		Bore Number		Contact Angle Symbol		Internal Design Symbol		Material Symbol		Cage Symbol		External Features									
Symbol	Meaning	Symbol	Meaning	Symbol	Meaning	Symbol	Meaning	Symbol	Meaning	Symbol	Meaning	Symbol	Meaning								
68	Single-Row Deep Groove Ball Bearings	1	Bearing Bore 1mm	A	(Angular Contact Ball Bearings)	A	Internal Design Differs from Standard One	g	Case-Hardened Steel Used in Rings, Rolling Elements	M	Machined Brass Cage	Z	Shield on One Side Only								
69	Single-Row Angular Contact Ball Bearings	2	2		J	Smaller Diameter of Outer Ring Raceway, Contact Angle, and Outer Ring Width of Tapered Roller Bearings Conform to ISO	J		Smaller Diameter of Outer Ring Raceway, Contact Angle, and Outer Ring Width of Tapered Roller Bearings Conform to ISO		h	Stainless Steel Used in Rings, Rolling Elements	W	Pressed Steel Cage	ZS	Shield on One Side Only					
70	Single-Row Angular Contact Ball Bearings	3	3		A5	Standard Contact Angle of 25°	W		Pressed Steel Cage		h	Stainless Steel Used in Rings, Rolling Elements	W	Pressed Steel Cage	ZZ	Shields on Both Sides					
72	Self-Aligning Ball Bearings	9	9	B	Standard Contact Angle of 40°	B	Standard Contact Angle of 40°	h	Stainless Steel Used in Rings, Rolling Elements	T	Synthetic Resin Cage	DU	Contact Rubber Seal on One Side Only								
73	Self-Aligning Ball Bearings	00	10		02		15				03	17	DU	Contact Rubber Seal on One Side Only	DDU	Contact Rubber Seals on Both Sides	ZZS	Shields on Both Sides			
12	Cylindrical Roller Bearings	01	12		02		15				03	17	DU	Contact Rubber Seal on One Side Only	DDU	Contact Rubber Seals on Both Sides	ZZS	Shields on Both Sides			
13	Cylindrical Roller Bearings	02	15	C	Standard Contact Angle of 15°	C	(For High Capacity Bearings)	h	Stainless Steel Used in Rings, Rolling Elements	V	Without Cage	DU	Contact Rubber Seal on One Side Only								
22	Cylindrical Roller Bearings	03	17		02		15				03	17	DU	Contact Rubber Seal on One Side Only	DDU	Contact Rubber Seals on Both Sides	ZZS	Shields on Both Sides			
NU10	Cylindrical Roller Bearings	/22	22		02		15				03	17	DU	Contact Rubber Seal on One Side Only	DDU	Contact Rubber Seals on Both Sides	ZZS	Shields on Both Sides			
NJ 2	Cylindrical Roller Bearings	/28	28	CA	(Tapered Roller Bearings)	CA	Spherical Roller Bearings	h	Stainless Steel Used in Rings, Rolling Elements	V	Without Cage	DU	Contact Rubber Seal on One Side Only								
N 3	Cylindrical Roller Bearings	/32	32									02	15	03	17	DU	Contact Rubber Seal on One Side Only	DDU	Contact Rubber Seals on Both Sides	ZZS	Shields on Both Sides
NN 30	Cylindrical Roller Bearings	/32	32									02	15	03	17	DU	Contact Rubber Seal on One Side Only	DDU	Contact Rubber Seals on Both Sides	ZZS	Shields on Both Sides
NA48	Needle Roller Bearings	04 <sup>(2)</sup>	20	Omitted	Contact Angle Less than 17°	EA	Spherical Roller Bearings	h	Stainless Steel Used in Rings, Rolling Elements	V	Without Cage	DU	Contact Rubber Seal on One Side Only								
NA49	Needle Roller Bearings	05	25									02	15	03	17	DU	Contact Rubber Seal on One Side Only	DDU	Contact Rubber Seals on Both Sides	ZZS	Shields on Both Sides
NA69	Needle Roller Bearings	06	30									02	15	03	17	DU	Contact Rubber Seal on One Side Only	DDU	Contact Rubber Seals on Both Sides	ZZS	Shields on Both Sides
320	Tapered Roller Bearings	08	440	C	Contact Angle about 20°	E	Cylindrical Roller Bearings	h	Stainless Steel Used in Rings, Rolling Elements	V	Without Cage	DU	Contact Rubber Seal on One Side Only								
322	Tapered Roller Bearings	09	450									02	15	03	17	DU	Contact Rubber Seal on One Side Only	DDU	Contact Rubber Seals on Both Sides	ZZS	Shields on Both Sides
323	Tapered Roller Bearings	10	500									02	15	03	17	DU	Contact Rubber Seal on One Side Only	DDU	Contact Rubber Seals on Both Sides	ZZS	Shields on Both Sides
230	Spherical Roller Bearings	92	460	D	Contact Angle about 28°	E	Spherical Thrust Roller Bearings	h	Stainless Steel Used in Rings, Rolling Elements	V	Without Cage	DU	Contact Rubber Seal on One Side Only								
222	Spherical Roller Bearings	96	480									02	15	03	17	DU	Contact Rubber Seal on One Side Only	DDU	Contact Rubber Seals on Both Sides	ZZS	Shields on Both Sides
223	Spherical Roller Bearings	/500	500									02	15	03	17	DU	Contact Rubber Seal on One Side Only	DDU	Contact Rubber Seals on Both Sides	ZZS	Shields on Both Sides
511	Thrust Ball Bearing with Flat Seats	/530	530	HR <sup>(4)</sup>	Tapered Roller Bearings	E	Spherical Thrust Roller Bearings	h	Stainless Steel Used in Rings, Rolling Elements	V	Without Cage	DU	Contact Rubber Seal on One Side Only								
512	Thrust Ball Bearing with Flat Seats	/560	560									02	15	03	17	DU	Contact Rubber Seal on One Side Only	DDU	Contact Rubber Seals on Both Sides	ZZS	Shields on Both Sides
513	Thrust Ball Bearing with Flat Seats	/560	560									02	15	03	17	DU	Contact Rubber Seal on One Side Only	DDU	Contact Rubber Seals on Both Sides	ZZS	Shields on Both Sides
292	Spherical Thrust Roller Bearings	/2 360	2 360	HR <sup>(4)</sup>	Tapered Roller Bearings	E	Spherical Thrust Roller Bearings	h	Stainless Steel Used in Rings, Rolling Elements	V	Without Cage	DU	Contact Rubber Seal on One Side Only								
293	Spherical Thrust Roller Bearings	/2 500	2 500									02	15	03	17	DU	Contact Rubber Seal on One Side Only	DDU	Contact Rubber Seals on Both Sides	ZZS	Shields on Both Sides
294	Spherical Thrust Roller Bearings	/2 500	2 500									02	15	03	17	DU	Contact Rubber Seal on One Side Only	DDU	Contact Rubber Seals on Both Sides	ZZS	Shields on Both Sides

Symbols and Numbers Conform to JIS<sup>(1)</sup>

NSK Symbol

NSK Symbol

Marked on Bearings

Not Marked on Bearings

- Notes** <sup>(1)</sup> Bearing Series Symbols conform to Table 7.5.  
<sup>(2)</sup> For basic numbers of tapered roller bearings in ISO's new series, refer to Page B111.  
<sup>(3)</sup> For Bearing Bore Numbers 04 through 96, five times the bore number gives the bore size (mm) (except double-direction thrust ball bearings).  
<sup>(4)</sup> HR is prefix to bearing series symbols.

Bearing Numbers

Auxiliary Symbols													
Symbol		Arrangement Symbol		Internal Clearance Symbol		Tolerance Class Symbol		Special Specification Symbol		Spacer or Sleeve Symbol		Grease Symbol	
Symbol for Design of Rings	Symbol Meaning	Symbol	Meaning	Symbol	Meaning (radial clearance)	Symbol	Meaning	Symbol	Meaning	Symbol	Meaning	Symbol	Meaning
K	Tapered Bore of Inner Ring (Taper 1:12)	DB	Back-to-Back Arrangement	C1	Clearance Less than C2	Omitted	ISO Normal	(Bearings treated for Dimensional Stabilization)	+K	Bearings with Outer Ring Spacers	AV2	Shell Alvania Grease No. 2	
				C2	Clearance Less than CN								
K30	Tapered Bore of Inner Ring (Taper 1:30)	DF	Face-to-Face Arrangement	Omitted	CN Clearance	P6X	ISO Class 6X	X26	Working Temperature Lower than 150° C	+L	Bearings with Inner Ring Spacers	D4M	Toray Silicone SH 44M
				C3	Clearance Greater than CN								
E	Notch or Lubricating Groove in Ring	DT	Tandem Arrangement	C4	Clearance Greater than C3	P5	ISO Class 5	X28	Working Temperature Lower than 200° C	+KL	Bearings with Both Inner and Outer Ring Spacers	PS2	Multemp PS 2
				C5	Clearance Greater than C4								
E4	Lubricating Groove in Outside Surface and Holes in Outer Ring	For Non-Interchangeable Cylindrical Roller Brigs.	For Non-Interchangeable Cylindrical Roller Brigs.	CC1	Clearance Less than CC2	P4	ISO Class 4	X29	Working Temperature Lower than 250° C	H	Adapter Designation	AH	Withdrawal Sleeve Designation
				CC2	Clearance Less than CC								
N	Snap Ring Groove in Outer Ring	For Extra-Small and Miniature Ball Brigs.	For Extra-Small and Miniature Ball Brigs.	CC3	Clearance Greater than CC	PN2	Class 2	S11	Working Temperature Lower than 200° C	HJ	Thrust Collar Designation	PS2	Multemp PS 2
				CC4	Clearance Greater than CC3								
NR	Snap Ring Groove with Snap Ring in Outer Ring	For Extra-Small and Miniature Ball Brigs.	For Extra-Small and Miniature Ball Brigs.	CC5	Clearance Greater than CC4	PN3	Class 3	S11	Working Temperature Lower than 200° C	HJ	Thrust Collar Designation	PS2	Multemp PS 2
				MC1	Clearance Less than MC2								
N	Snap Ring Groove in Outer Ring	For Extra-Small and Miniature Ball Brigs.	For Extra-Small and Miniature Ball Brigs.	MC2	Clearance Less than MC3	PN0	Class 0	S11	Working Temperature Lower than 200° C	HJ	Thrust Collar Designation	PS2	Multemp PS 2
				MC3	Normal Clearance								
NR	Snap Ring Groove with Snap Ring in Outer Ring	For Extra-Small and Miniature Ball Brigs.	For Extra-Small and Miniature Ball Brigs.	MC4	Clearance Greater than MC3	PN00	Class 00	S11	Working Temperature Lower than 200° C	HJ	Thrust Collar Designation	PS2	Multemp PS 2
				MC5	Clearance Greater than MC4								
NR	Snap Ring Groove with Snap Ring in Outer Ring	For Extra-Small and Miniature Ball Brigs.	For Extra-Small and Miniature Ball Brigs.	MC6	Clearance Greater than MC5	PN00	Class 00	S11	Working Temperature Lower than 200° C	HJ	Thrust Collar Designation	PS2	Multemp PS 2
				CM	Clearance in Deep Groove Ball Bearings for Electric Motors								
NR	Snap Ring Groove with Snap Ring in Outer Ring	For Extra-Small and Miniature Ball Brigs.	For Extra-Small and Miniature Ball Brigs.	CT	Clearance in Cylindrical Roller Bearings for Electric Motors	PN00	Class 00	S11	Working Temperature Lower than 200° C	HJ	Thrust Collar Designation	PS2	Multemp PS 2
				CM	Clearance in Cylindrical Roller Bearings for Electric Motors								

Partially the same as JIS<sup>(1)</sup>

Same as JIS<sup>(1)</sup>

NSK Symbol  
Partially the same as JIS<sup>(1)</sup>/  
BAS<sup>(2)</sup>

Same as JIS<sup>(1)</sup>

NSK Symbol, Partially the same as JIS<sup>(1)</sup>

In Principle, Marked on Bearings

Not Marked on Bearings

- Notes** <sup>(1)</sup> JIS : Japanese Industrial Standards.  
<sup>(2)</sup> BAS : The Japan Bearing Industrial Association Standard.  
<sup>(3)</sup> ABMA : The American Bearing Manufacturers Association.



## 8. BEARING TOLERANCES

### 8.1 Bearing Tolerance Standards

The tolerances for the boundary dimensions and running accuracy of rolling bearings are specified by ISO 492/199/582 (Accuracies of Rolling Bearings). Tolerances are specified for the following items:

Regarding bearing accuracy classes, besides ISO normal accuracy, as the accuracy improves there are Class 6X (for tapered roller bearings), Class 6, Class 5, Class 4, and Class 2, with Class 2 being the highest in ISO. The applicable accuracy classes for each bearing type and the correspondence of these classes are shown in Table 8.1.

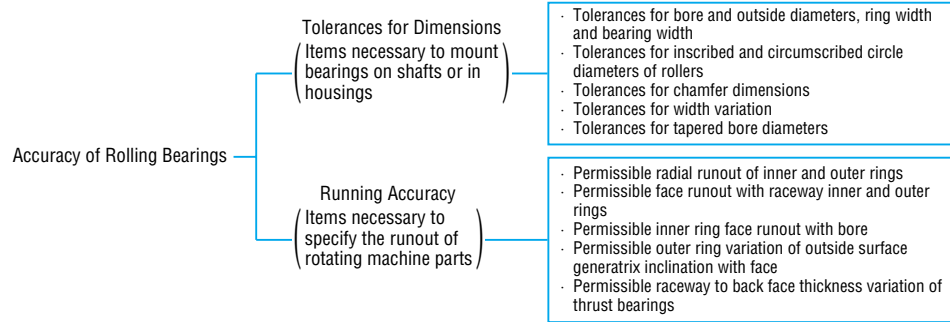

Table 8.1 Bearing Types and Tolerance Classes

Bearing Types		Applicable Tolerance Classes					Applicable Tables	Reference Pages
Deep Groove Ball Bearings	Normal	Class 6	Class 5	Class 4	Class 2	Table 8.2	A60 ~A63	
Angular Contact Ball Bearings	Normal	Class 6	Class 5	Class 4	Class 2			
Self-Aligning Ball Bearings	Normal	Class 6 equivalent	Class 5 equivalent	—	—			
Cylindrical Roller Bearings	Normal	Class 6	Class 5	Class 4	Class 2			
Needle Roller Bearings (solid type)	Normal	Class 6	Class 5	Class 4	—			
Spherical Roller Bearings	Normal	Class 6	Class 5	—	—			
Tapered Roller Bearings	Metric Design	Normal Class 6X	—	Class 5	Class 4	—	Table 8.3	A64 ~A67
	Inch Design	ANSI/ABMA CLASS 4	ANSI/ABMA CLASS 2	ANSI/ABMA CLASS 3	ANSI/ABMA CLASS 0	ANSI/ABMA CLASS 00	Table 8.4	A68 ~A69
Magneto Bearings	Normal	Class 6	Class 5	—	—	Table 8.5	A70 ~A71	
Thrust Ball Bearings	Normal	Class 6	Class 5	Class 4	—	Table 8.4	A72 ~A74	
Spherical Thrust Roller Bearings	Normal	—	—	—	—	Table 8.7	A75	
Equivalent standards (Reference)	JIS <sup>(1)</sup>	Class 0	Class 6	Class 5	Class 4	Class 2	—	—
	DIN <sup>(2)</sup>	P0	P6	P5	P4	P2	—	—
	ANSI/ABMA <sup>(3)</sup>	Ball Bearings	ABEC 1	ABEC 3	ABEC 5 (CLASS 5P)	ABEC 7 (CLASS 7P)	ABEC 9 (CLASS 9P)	Table 8.2
Roller Bearings		RBEC 1	RBEC 3	RBEC 5	—	—	[Table 8.8]	—
Tapered Roller Bearings		CLASS 4	CLASS 2	CLASS 3	CLASS 0	CLASS 00	[Table 8.4]	(A68 ~A69)

Notes <sup>(1)</sup> JIS : Japanese Industrial Standards <sup>(2)</sup> DIN : Deutsch Industrie Norm

<sup>(3)</sup> ANSI/ABMA : The American Bearing Manufacturers Association

Remarks The permissible limit of chamfer dimensions shall conform to Table 8.9 (Page A78), and the tolerances and permissible tapered bore diameters shall conform to Table 8.10 (Page A80).

(Reference) Rough definitions of the items listed for Running Accuracy and their measuring methods are shown in Fig. 8.1, and they are described in detail in ISO 5593 (Rolling Bearings-Vocabulary) and JIS B 1515 (Measuring Methods for Rolling Bearings) and elsewhere.

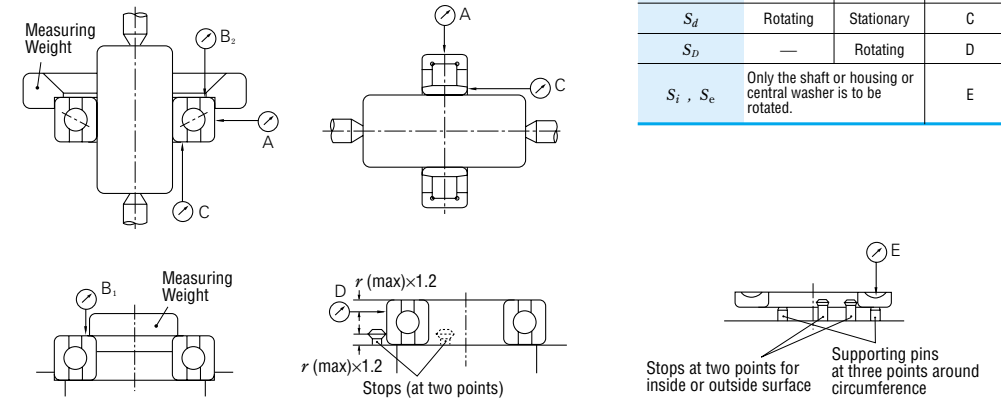

Fig. 8.1 Measuring Methods for Running Accuracy (summarized)

Supplementary Table

Running Accuracy	Inner Ring	Outer Ring	Dial Gauge
$K_{ia}$	Rotating	Stationary	A
$K_{ea}$	Stationary	Rotating	A
$S_{ia}$	Rotating	Stationary	$B_1$
$S_{ea}$	Stationary	Rotating	$B_2$
$S_d$	Rotating	Stationary	C
$S_D$	—	Rotating	D
$S_i, S_e$	Only the shaft or housing or central washer is to be rotated.		E

### Symbols for Boundary Dimensions and Running Accuracy

- |                |   |                |   |
|----------------|---|----------------|---|
| $d$            | Brg bore dia., nominal  | $D$            | Brg outside dia., nominal   |
| $\Delta_{ds}$  | Deviation of a single bore dia.   | $\Delta_{Ds}$  | Deviation of a single outside dia.  |
| $\Delta_{dmp}$ | Single plane mean bore dia. deviation   | $\Delta_{Dmp}$ | Single plane mean outside dia. Deviation  |
| $V_{dp}$       | Bore dia. Variation in a single radial plane  | $V_{Dp}$       | Outside dia. Variation in a single radial plane   |
| $V_{dmp}$      | Mean bore dia. Variation  | $V_{Dmp}$      | Mean outside dia. Variation   |
| $B$            | Inner ring width, nominal   | $C$            | Outer ring width, nominal   |
| $\Delta_{Bs}$  | Deviation of a single inner ring width  | $\Delta_{Cs}$  | Deviation of a single outer ring width  |
| $V_{Bs}$       | Inner ring width variation  | $V_{Cs}$       | Outer ring width variation  |
| $K_{ia}$       | Radial runout of assembled brg inner ring inner ring reference face (backface, where applicable) runout with bore | $K_{ea}$       | Radial runout of assembled brg outer ring variation of brg outside surface generatrix inclination with outer ring reference face (backface) |
| $S_d$          | Assembled brg inner ring face (back face) runout with raceway   | $S_D$          | Assembled brg outer ring face (backface) runout with raceway  |
| $S_i, S_e$     | Raceway to backface thickness variation of thrust brg   |                |   |
| $T$            | Brg width, nominal  |                |   |
| $\Delta_{Ts}$  | Deviation of the actual brg width   |                |   |

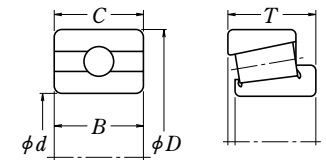



Table 8. 2 Tolerances for Radial Bearings

Table 8. 2. 1 Tolerances for Inner Rings and

Nominal Bore Diameter <i>d</i> (mm)		$\Delta_{dmp} (^\circ)$										$\Delta_{ds} (^\circ)$					
		Normal		Class 6		Class 5		Class 4		Class 2		Class 4		Class 2			
												Diameter Series					
over	incl	high	low	high	low	high	low	high	low	high	low	high	low	high	low	high	low
0.6 <sup>(1)</sup>	2.5	0	-8	0	-7	0	-5	0	-4	0	-2.5	0	-4	0	-2.5		
2.5	10	0	-8	0	-7	0	-5	0	-4	0	-2.5	0	-4	0	-2.5		
10	18	0	-8	0	-7	0	-5	0	-4	0	-2.5	0	-4	0	-2.5		
18	30	0	-10	0	-8	0	-6	0	-5	0	-2.5	0	-5	0	-2.5		
30	50	0	-12	0	-10	0	-8	0	-6	0	-2.5	0	-6	0	-2.5		
50	80	0	-15	0	-12	0	-9	0	-7	0	-4	0	-7	0	-4		
80	120	0	-20	0	-15	0	-10	0	-8	0	-5	0	-8	0	-5		
120	150	0	-25	0	-18	0	-13	0	-10	0	-7	0	-10	0	-7		
150	180	0	-25	0	-18	0	-13	0	-10	0	-7	0	-10	0	-7		
180	250	0	-30	0	-22	0	-15	0	-12	0	-8	0	-12	0	-8		
250	315	0	-35	0	-25	0	-18	-	-	-	-	-	-	-	-		
315	400	0	-40	0	-30	0	-23	-	-	-	-	-	-	-	-		
400	500	0	-45	0	-35	-	-	-	-	-	-	-	-	-	-		
500	630	0	-50	0	-40	-	-	-	-	-	-	-	-	-	-		
630	800	0	-75	-	-	-	-	-	-	-	-	-	-	-	-		
800	1 000	0	-100	-	-	-	-	-	-	-	-	-	-	-	-		
1 000	1 250	0	-125	-	-	-	-	-	-	-	-	-	-	-	-		
1 250	1 600	0	-160	-	-	-	-	-	-	-	-	-	-	-	-		
1 600	2 000	0	-200	-	-	-	-	-	-	-	-	-	-	-	-		

(excluding Tapered Roller Bearings)

Widths of Outer Rings

$V_{dp} (^\circ)$															$V_{dmp} (^\circ)$				
Normal			Class 6			Class 5			Class 4			Class 2			Normal	Class 6	Class 5	Class 4	Class 2
Diameter Series			Diameter Series			Diameter Series			Diameter Series			Diameter Series							
9	0, 1	2, 3, 4	9	0, 1	2, 3, 4	9	0, 1, 2, 3, 4	9	0, 1, 2, 3, 4	9	0, 1, 2, 3, 4	9	0, 1, 2, 3, 4	9					
max			max			max			max			max			max	max	max	max	max
10	8	6	9	7	5	5	4	4	3	2.5	6	5	3	2	1.5				
10	8	6	9	7	5	5	4	4	3	2.5	6	5	3	2	1.5				
10	8	6	9	7	5	5	4	4	3	2.5	6	5	3	2	1.5				
13	10	8	10	8	6	6	5	5	4	2.5	8	6	3	2.5	1.5				
15	12	9	13	10	8	8	6	6	5	2.5	9	8	4	3	1.5				
19	19	11	15	15	9	9	7	7	5	4	11	9	5	3.5	2				
25	25	15	19	19	11	10	8	8	6	5	15	11	5	4	2.5				
31	31	19	23	23	14	13	10	10	8	7	19	14	7	5	3.5				
31	31	19	23	23	14	13	10	10	8	7	19	14	7	5	3.5				
38	38	23	28	28	17	15	12	12	9	8	23	17	8	6	4				
44	44	26	31	31	19	18	14	-	-	-	26	19	9	-	-				
50	50	30	38	38	23	23	18	-	-	-	30	23	12	-	-				
56	56	34	44	44	26	-	-	-	-	-	34	26	-	-	-				
63	63	38	50	50	30	-	-	-	-	-	38	30	-	-	-				
-	-	-	-	-	-	-	-	-	-	-	-	-	-	-	-				
-	-	-	-	-	-	-	-	-	-	-	-	-	-	-	-				
-	-	-	-	-	-	-	-	-	-	-	-	-	-	-	-				
-	-	-	-	-	-	-	-	-	-	-	-	-	-	-	-				
-	-	-	-	-	-	-	-	-	-	-	-	-	-	-	-				

Units :  $\mu\text{m}$

$\Delta_{Bs} \text{ (or } \Delta_{Cs}) (^\circ)$											$V_{Bs} \text{ (or } V_{Cs})$					
Single Bearing						Combined Bearings (°)					Inner Ring (or Outer Ring) (°)		Inner Ring			
Normal Class 6		Class 5 Class 4		Class 2		Normal Class 6		Class 5 Class 4		Class 2		Normal	Class 6	Class 5	Class 4	Class 2
high	low	high	low	high	low	high	low	high	low	high	low	max	max	max	max	max
0	-40	0	-40	0	-40	-	-	0	-250	0	-250	12	12	5	2.5	1.5
0	-120	0	-40	0	-40	0	-250	0	-250	0	-250	15	15	5	2.5	1.5
0	-120	0	-80	0	-80	0	-250	0	-250	0	-250	20	20	5	2.5	1.5
0	-120	0	-120	0	-120	0	-250	0	-250	0	-250	20	20	5	3	1.5
0	-120	0	-120	0	-120	0	-250	0	-250	0	-250	20	20	5	3	1.5
0	-150	0	-150	0	-150	0	-380	0	-250	0	-250	25	25	6	4	1.5
0	-200	0	-200	0	-200	0	-380	0	-380	0	-380	25	25	7	4	2.5
0	-250	0	-250	0	-250	0	-500	0	-380	0	-380	30	30	8	5	2.5
0	-250	0	-250	0	-250	0	-500	0	-380	0	-380	30	30	8	5	4
0	-300	0	-300	0	-300	0	-500	0	-500	0	-500	30	30	10	6	5
0	-350	0	-350	-	-	0	-500	0	-500	-	-	35	35	13	-	-
0	-400	0	-400	-	-	0	-630	0	-630	-	-	40	40	15	-	-
0	-450	-	-	-	-	-	-	-	-	-	-	50	45	-	-	-
0	-500	-	-	-	-	-	-	-	-	-	-	60	50	-	-	-
0	-750	-	-	-	-	-	-	-	-	-	-	70	-	-	-	-
0	-1 000	-	-	-	-	-	-	-	-	-	-	80	-	-	-	-
0	-1 250	-	-	-	-	-	-	-	-	-	-	100	-	-	-	-
0	-1 600	-	-	-	-	-	-	-	-	-	-	120	-	-	-	-
0	-2 000	-	-	-	-	-	-	-	-	-	-	140	-	-	-	-

- Notes**
- (1) 0.6mm is included in the group.
  - (2) Applicable to bearings with cylindrical bores.
  - (3) Tolerance for width deviation and tolerance limits for the width variation of the outer ring should be the same bearing. Tolerances for the width variation of the outer ring of Class 5, 4, and 2 are shown in Table 8.2.2.
  - (4) Applicable to individual rings manufactured for combined bearings.
  - (5) Applicable to ball bearings such as deep groove ball bearings, angular contact ball bearings, etc.

$K_{ia}$					$S_d$			$S_{ia} (^\circ)$			Nominal Bore Diameter <i>d</i> (mm)	
Normal	Class 6	Class 5	Class 4	Class 2	Class 5	Class 4	Class 2	Class 5	Class 4	Class 2		
max	max	max	max	max	max	max	max	max	max	max	over	incl
10	5	4	2.5	1.5	7	3	1.5	7	3	1.5	0.6 <sup>(1)</sup>	2.5
10	6	4	2.5	1.5	7	3	1.5	7	3	1.5	2.5	10
10	7	4	2.5	1.5	7	3	1.5	7	3	1.5	10	18
13	8	4	3	2.5	8	4	1.5	8	4	2.5	18	30
15	10	5	4	2.5	8	4	1.5	8	4	2.5	30	50
20	10	5	4	2.5	8	5	1.5	8	5	2.5	50	80
25	13	6	5	2.5	9	5	2.5	9	5	2.5	80	120
30	18	8	6	2.5	10	6	2.5	10	7	2.5	120	150
30	18	8	6	5	10	6	4	10	7	5	150	180
40	20	10	8	5	11	7	5	13	8	5	180	250
50	25	13	-	-	13	-	-	15	-	-	250	315
60	30	15	-	-	15	-	-	20	-	-	315	400
65	35	-	-	-	-	-	-	-	-	-	400	500
70	40	-	-	-	-	-	-	-	-	-	500	630
80	-	-	-	-	-	-	-	-	-	-	630	800
90	-	-	-	-	-	-	-	-	-	-	800	1 000
100	-	-	-	-	-	-	-	-	-	-	1 000	1 250
120	-	-	-	-	-	-	-	-	-	-	1 250	1 600
140	-	-	-	-	-	-	-	-	-	-	1 600	2 000

- Remarks**
- The cylindrical bore diameter "no-go side" tolerance limit (high) specified in this table does not necessarily apply within a distance of 1.2 times the chamfer dimension  $r$  (max) from the ring face.
  - ABMA Std 20-1987 was amended: ABEC1-RBEC1, ABEC3-RBEC3, ABEC5-RBEC5, ABEC7, and ABEC9 are equivalent to Classes Normal, 6, 5, 4, and 2 respectively.



Table 8. 3 Tolerances for Metric Design Tapered Roller Bearings

Table 8. 3. 1 Tolerances for Inner Ring Bore Diameter and Running Accuracy

Nominal Bore Diameter $d$ (mm)		$\Delta_{dmp}$				$\Delta_{ds}$		$V_{dp}$				$V_{dmp}$					
		Normal Class 6X		Class 6 Class 5		Class 4		Class 4		Normal Class 6X	Class 6	Class 5	Class 4	Normal Class 6X	Class 6	Class 5	Class 4
over	incl	high	low	high	low	high	low	high	low	max	max	max	max	max	max	max	max
10	18	0	-8	0	-7	0	-5	0	-5	8	7	5	4	6	5	5	4
18	30	0	-10	0	-8	0	-6	0	-6	10	8	6	5	8	6	5	4
30	50	0	-12	0	-10	0	-8	0	-8	12	10	8	6	9	8	5	5
50	80	0	-15	0	-12	0	-9	0	-9	15	12	9	7	11	9	6	5
80	120	0	-20	0	-15	0	-10	0	-10	20	15	11	8	15	11	8	5
120	180	0	-25	0	-18	0	-13	0	-13	25	18	14	10	19	14	9	7
180	250	0	-30	0	-22	0	-15	0	-15	30	22	17	11	23	16	11	8
250	315	0	-35	0	-25	0	-18	0	-18	35	-	-	-	26	-	-	-
315	400	0	-40	0	-30	0	-23	0	-23	40	-	-	-	30	-	-	-
400	500	0	-45	0	-35	0	-27	0	-27	-	-	-	-	-	-	-	-
500	630	0	-50	0	-40	-	-	-	-	-	-	-	-	-	-	-	-
630	800	0	-75	0	-60	-	-	-	-	-	-	-	-	-	-	-	-

Remarks 1. The bore diameter "no-go side" tolerances (high) specified in this table do not necessarily apply within a distance of 1.2 times the chamfer dimension  $r$  (max) from the ring face.  
2. Some of these tolerances conform to the NSK Standard.

Table 8. 3. 2 Tolerances for Outer Ring Outside Diameter and Running Accuracy

Nominal Outside Diameter $D$ (mm)		$\Delta_{Dmp}$				$\Delta_{Ds}$		$V_{Dp}$				$V_{Dmp}$					
		Normal Class 6X		Class 6 Class 5		Class 4		Class 4		Normal Class 6X	Class 6	Class 5	Class 4	Normal Class 6X	Class 6	Class 5	Class 4
over	incl	high	low	high	low	high	low	high	low	max	max	max	max	max	max	max	max
18	30	0	-9	0	-8	0	-6	0	-6	9	8	6	5	7	6	5	4
30	50	0	-11	0	-9	0	-7	0	-7	11	9	7	5	8	7	5	5
50	80	0	-13	0	-11	0	-9	0	-9	13	11	8	7	10	8	6	5
80	120	0	-15	0	-13	0	-10	0	-10	15	13	10	8	11	10	7	5
120	150	0	-18	0	-15	0	-11	0	-11	18	15	11	8	14	11	8	6
150	180	0	-25	0	-18	0	-13	0	-13	25	18	14	10	19	14	9	7
180	250	0	-30	0	-20	0	-15	0	-15	30	20	15	11	23	15	10	8
250	315	0	-35	0	-25	0	-18	0	-18	35	25	19	14	26	19	13	9
315	400	0	-40	0	-28	0	-20	0	-20	40	28	22	15	30	21	14	10
400	500	0	-45	0	-33	0	-23	0	-23	45	-	-	-	34	-	-	-
500	630	0	-50	0	-38	0	-28	0	-28	50	-	-	-	38	-	-	-
630	800	0	-75	0	-45	-	-	-	-	-	-	-	-	-	-	-	-
800	1000	0	-100	0	-60	-	-	-	-	-	-	-	-	-	-	-	-

Remarks 1. The outside diameter "no-go side" tolerances (low) specified in this table do not necessarily apply within a distance of 1.2 times the chamfer dimension  $r$  (max) from the ring face.  
2. Some of these tolerances conform to the NSK Standard.

Units :  $\mu\text{m}$

$K_{ia}$				$S_d$		$S_{ia}$
Normal Class 6X	Class 6	Class 5	Class 4	Class 5	Class 4	Class 4
max	max	max	max	max	max	max
15	7	3.5	2.5	7	3	3
18	8	4	3	8	4	4
20	10	5	4	8	4	4
25	10	5	4	8	5	4
30	13	6	5	9	5	5
35	18	8	6	10	6	7
50	20	10	8	11	7	8
60	25	13	10	13	8	10
70	30	15	12	15	10	14
70	35	18	14	19	13	17
85	40	20	-	22	-	-
100	45	22	-	27	-	-

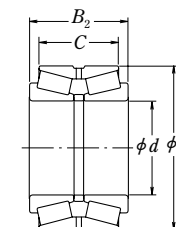
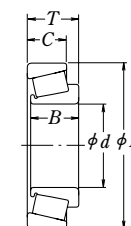

Units :  $\mu\text{m}$

$K_{ea}$				$S_D$		$S_{ea}$
Normal Class 6X	Class 6	Class 5	Class 4	Class 5	Class 4	Class 4
max	max	max	max	max	max	max
18	9	6	4	8	4	5
20	10	7	5	8	4	5
25	13	8	5	8	4	5
35	18	10	6	9	5	6
40	20	11	7	10	5	7
45	23	13	8	10	5	8
50	25	15	10	11	7	10
60	30	18	11	13	8	10
70	35	20	13	13	10	13
80	40	23	15	15	11	15
100	50	25	18	18	13	18
120	60	30	-	20	-	-
120	75	35	-	23	-	-

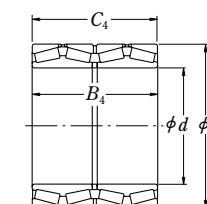

**Table 8. 3 Tolerances for Metric Design**  
**Table 8. 3. 3 Tolerances for Width, Overall Bearing Width,**

Nominal Bore Diameter $d$ (mm)		$\Delta_{Bs}$						$\Delta_{Cs}$						$\Delta_{Ts}$					
		Normal Class 6		Class 6X		Class 5 Class 4		Normal Class 6		Class 6X		Class 5 Class 4		Normal Class 6		Class 6X		Class 5 Class 4	
over	incl	high	low	high	low	high	low	high	low	high	low	high	low	high	low	high	low	high	low
<b>10</b>	<b>18</b>	0	-120	0	-50	0	-200	0	-120	0	-100	0	-200	+200	0	+100	0	+200	-200
<b>18</b>	<b>30</b>	0	-120	0	-50	0	-200	0	-120	0	-100	0	-200	+200	0	+100	0	+200	-200
<b>30</b>	<b>50</b>	0	-120	0	-50	0	-240	0	-120	0	-100	0	-240	+200	0	+100	0	+200	-200
<b>50</b>	<b>80</b>	0	-150	0	-50	0	-300	0	-150	0	-100	0	-300	+200	0	+100	0	+200	-200
<b>80</b>	<b>120</b>	0	-200	0	-50	0	-400	0	-200	0	-100	0	-400	+200	-200	+100	0	+200	-200
<b>120</b>	<b>180</b>	0	-250	0	-50	0	-500	0	-250	0	-100	0	-500	+350	-250	+150	0	+350	-250
<b>180</b>	<b>250</b>	0	-300	0	-50	0	-600	0	-300	0	-100	0	-600	+350	-250	+150	0	+350	-250
<b>250</b>	<b>315</b>	0	-350	0	-50	0	-700	0	-350	0	-100	0	-700	+350	-250	+200	0	+350	-250
<b>315</b>	<b>400</b>	0	-400	0	-50	0	-800	0	-400	0	-100	0	-800	+400	-400	+200	0	+400	-400
<b>400</b>	<b>500</b>	0	-450	-	-	0	-800	0	-450	-	-	0	-800	+400	-400	-	-	+400	-400
<b>500</b>	<b>630</b>	0	-500	-	-	0	-800	-	-	0	-	0	-800	+500	-500	-	-	+500	-500
<b>630</b>	<b>800</b>	0	-750	-	-	0	-800	-	-	0	-	0	-800	+600	-600	-	-	+600	-600

**Remarks** The effective width of an inner ring with rollers  $T_1$  is defined as the overall bearing width of an inner ring with rollers combined with a master outer ring.  
 The effective width of an outer ring  $T_2$  is defined as the overall bearing width of an outer ring combined with a master inner ring with rollers.

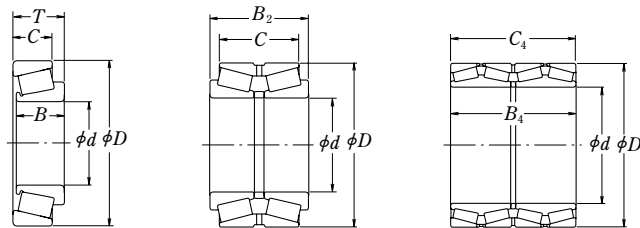

**Tapered Roller Bearings and Combined Bearing Width**

Units :  $\mu\text{m}$

Ring Width with Rollers $\Delta_{T1s}$				Outer Ring Effective Width Deviation $\Delta_{T2s}$				Overall Combined Bearing Width Deviation $\Delta_{B2s}$				Nominal Bore Diameter $d$ (mm)	
Normal		Class 6X		Normal		Class 6X		All classes of double-row bearings		All classes of four-row bearings			
high	low	high	low	high	low	high	low	high	low	high	low	over	incl
+100	0	+ 50	0	+100	0	+ 50	0	+ 200	- 200	-	-	<b>10</b>	<b>18</b>
+100	0	+ 50	0	+100	0	+ 50	0	+ 200	- 200	-	-	<b>18</b>	<b>30</b>
+100	0	+ 50	0	+100	0	+ 50	0	+ 200	- 200	-	-	<b>30</b>	<b>50</b>
+100	0	+ 50	0	+100	0	+ 50	0	+ 300	- 300	+ 300	- 300	<b>50</b>	<b>80</b>
+100	-100	+ 50	0	+100	-100	+ 50	0	+ 300	- 300	+ 400	- 400	<b>80</b>	<b>120</b>
+150	-150	+ 50	0	+200	-100	+100	0	+ 400	- 400	+ 500	- 500	<b>120</b>	<b>180</b>
+150	-150	+ 50	0	+200	-100	+100	0	+ 450	- 450	+ 600	- 600	<b>180</b>	<b>250</b>
+150	-150	+100	0	+200	-100	+100	0	+ 550	- 550	+ 700	- 700	<b>250</b>	<b>315</b>
+200	-200	+100	0	+200	-200	+100	0	+ 600	- 600	+ 800	- 800	<b>315</b>	<b>400</b>
-	-	-	-	-	-	-	-	+ 700	- 700	+ 900	- 900	<b>400</b>	<b>500</b>
-	-	-	-	-	-	-	-	+ 800	- 800	+1 000	-1 000	<b>500</b>	<b>630</b>
-	-	-	-	-	-	-	-	+1 200	-1 200	+1 500	-1 500	<b>630</b>	<b>800</b>

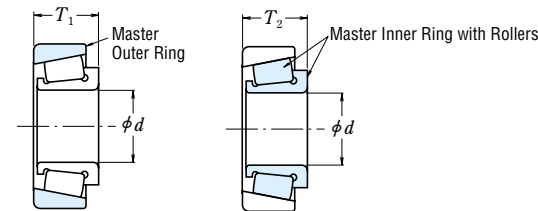

Table 8. 4 Tolerances for Inch Design Tapered Roller Bearings

Table 8. 4. 1 Tolerances for Inner Ring Bore Diameter

Units :  $\mu\text{m}$

Nominal Bore Diameter $d$				$\Delta_{ds}$					
over		incl		CLASS 4, 2		CLASS 3, 0		CLASS 00	
(mm)	1/25.4	(mm)	1/25.4	high	low	high	low	high	low
—	—	<b>76.200</b>	3.0000	+ 13	0	+13	0	+8	0
<b>76.200</b>	3.0000	<b>266.700</b>	10.5000	+ 25	0	+13	0	+8	0
<b>266.700</b>	10.5000	<b>304.800</b>	12.0000	+ 25	0	+13	0	—	—
<b>304.800</b>	12.0000	<b>609.600</b>	24.0000	+ 51	0	+25	0	—	—
<b>609.600</b>	24.0000	<b>914.400</b>	36.0000	+ 76	0	+38	0	—	—
<b>914.400</b>	36.0000	<b>1 219.200</b>	48.0000	+102	0	+51	0	—	—
<b>1 219.200</b>	48.0000	—	—	+127	0	+76	0	—	—

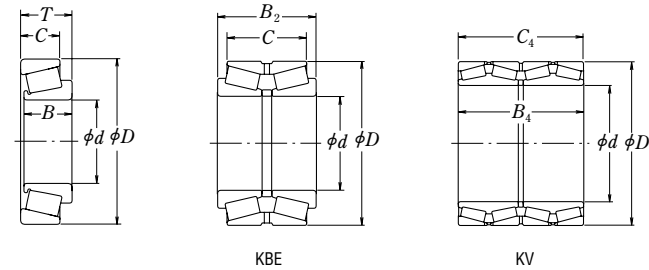

Table 8. 4. 2 Tolerances for Outer Ring Outside Diameter

Nominal Outside Diameter $D$				$\Delta_{Ds}$					
over		incl		CLASS 4, 2		CLASS 3, 0		CLASS 00	
(mm)	1/25.4	(mm)	1/25.4	high	low	high	low	high	low
—	—	<b>266.700</b>	10.5000	+ 25	0	+13	0	+8	0
<b>266.700</b>	10.5000	<b>304.800</b>	12.0000	+ 25	0	+13	0	+8	0
<b>304.800</b>	12.0000	<b>609.600</b>	24.0000	+ 51	0	+25	0	—	—
<b>609.600</b>	24.0000	<b>914.400</b>	36.0000	+ 76	0	+38	0	—	—
<b>914.400</b>	36.0000	<b>1 219.200</b>	48.0000	+102	0	+51	0	—	—
<b>1 219.200</b>	48.0000	—	—	+127	0	+76	0	—	—

and Radial Runout of Inner and Outer Rings

Units :  $\mu\text{m}$

$K_{ia}, K_{ea}$				
CLASS 4	CLASS 2	CLASS 3	CLASS 0	CLASS 00
max	max	max	max	max
51	38	8	4	2
51	38	8	4	2
51	38	18	—	—
76	51	51	—	—
76	—	76	—	—
76	—	76	—	—

Table 8. 4. 3 Tolerances for

Nominal Bore Diameter $d$				$\Delta_{Ts}$									
over		incl		CLASS 4		CLASS 2		CLASS 3				CLASS 0, 00	
(mm)	1/25.4	(mm)	1/25.4	high	low	high	low	$D \leq 508.000$ (mm)		$D > 508.000$ (mm)		high	low
								high	low	high	low		
—	—	<b>101.600</b>	4.0000	+203	0	+203	0	+203	-203	+203	-203	+203	-203
<b>101.600</b>	4.0000	<b>304.800</b>	12.0000	+356	-254	+203	0	+203	-203	+203	-203	+203	-203
<b>304.800</b>	12.0000	<b>609.600</b>	24.0000	+381	-381	+381	-381	+203	-203	+381	-381	—	—
<b>609.600</b>	24.0000	—	—	+381	-381	—	—	+381	-381	+381	-381	—	—

Overall Width and Combined Width

Units :  $\mu\text{m}$

Double-Row Bearings (KBE Type)										Four-Row Bearings (KV Type)	
$\Delta_{B2s}$										$\Delta_{B4s}, \Delta_{C4s}$	
CLASS 4		CLASS 2		CLASS 3				CLASS 0,00		CLASS 4, 3	
high	low	high	low	$D \leq 508.000$ (mm)		$D > 508.000$ (mm)		high	low	high	low
				high	low	high	low				
+406	0	+406	0	+406	-406	+406	-406	+406	-406	+1 524	-1 524
+711	-508	+406	-203	+406	-406	+406	-406	+406	-406	+1 524	-1 524
+762	-762	+762	-762	+406	-406	+762	-762	—	—	+1 524	-1 524
+762	-762	—	—	+762	-762	+762	-762	—	—	+1 524	-1 524

**Table 8. 5 Tolerances**  
**Table 8. 5. 1 Tolerances for Inner Rings**

Nominal Bore Diameter $d$ (mm)		$\Delta_{dmp}$						$V_{dp}$			$V_{dmp}$			$\Delta_{Bs}$ (or $\Delta_{Cs}$ ) <sup>(1)</sup>			
		Normal		Class 6		Class 5		Normal	Class 6	Class 5	Normal	Class 6	Class 5	Normal Class 6		Class 5	
		over	incl	high	low	high	low	high	low	max	max	max	max	max	high	low	high
<b>2.5</b>	<b>10</b>	0	-8	0	-7	0	-5	6	5	4	6	5	3	0	-120	0	-40
<b>10</b>	<b>18</b>	0	-8	0	-7	0	-5	6	5	4	6	5	3	0	-120	0	-80
<b>18</b>	<b>30</b>	0	-10	0	-8	0	-6	8	6	5	8	6	3	0	-120	0	-120

**Note** <sup>(1)</sup> The width deviation and width variation of an outer ring is determined according to the inner ring of the same bearing.

**Remarks** The bore diameter "no-go side" tolerances (high) specified in this table do not necessarily apply within a distance of 1.2 times the chamfer dimension  $r$  (max) from the ring face.

**Table 8. 5. 2 Tolerances**

Nominal Outside Diameter $D$ (mm)		$\Delta_{Dmp}$										$V_{Dp}$				
		Bearing Series E						Bearing Series EN				Normal	Class 6	Class 5		
		Normal		Class 6		Class 5		Normal		Class 6					Class 5	
over	incl	high	low	high	low	high	low	high	low	high	low	high	low	max	max	max
<b>6</b>	<b>18</b>	+8	0	+7	0	+5	0	0	-8	0	-7	0	-5	6	5	4
<b>18</b>	<b>30</b>	+9	0	+8	0	+6	0	0	-9	0	-8	0	-6	7	6	5
<b>30</b>	<b>50</b>	+11	0	+9	0	+7	0	0	-11	0	-9	0	-7	8	7	5

**Remarks** The outside diameter "no-go side" tolerances (low) do not necessarily apply within a distance of 1.2 times the chamfer dimension  $r$  (max) from the ring face.

**for Magneto Bearings and Width of Outer Rings**

Units :  $\mu\text{m}$

$V_{Bs}$ (or $V_{Cs}$ ) <sup>(1)</sup>		$\Delta_{Ts}$		$K_{ia}$			$S_d$	$S_{ia}$
				Normal Class 6	Class 5	Class 5		
Normal Class 6	Class 5	Normal Class 6	Class 5	Normal	Class 6	Class 5	Class 5	Class 5
max	max	high	low	max	max	max	max	max
15	5	+120	-120	10	6	4	7	7
20	5	+120	-120	10	7	4	7	7
20	5	+120	-120	13	8	4	8	8

**for Outer Rings**

Units :  $\mu\text{m}$

$V_{Dmp}$			$K_{ea}$			$S_{ea}$	$S_D$
Normal	Class 6	Class 5	Normal	Class 6	Class 5		
max	max	max	max	max	max	max	max
6	5	3	15	8	5	8	8
7	6	3	15	9	6	8	8
8	7	4	20	10	7	8	8

Table 8. 6 Tolerances for Thrust Ball Bearings

Table 8. 6. 1 Tolerances for Shaft Washer Bore Diameter and Running Accuracy

Units :  $\mu\text{m}$

Nominal Bore Diameter $d$ or $d_2$ (mm)		$\Delta_{dmp}$ or $\Delta_{d2mp}$				$V_{dp}$ or $V_{d2p}$		$S_i$ or $S_e$ (°)			
								Normal Class 6 Class 5	Class 4		Normal Class 6 Class 5
		over	incl	high	low	high	low	max	max	max	max
—	<b>18</b>	0	- 8	0	- 7	6	5	10	5	3	2
<b>18</b>	<b>30</b>	0	- 10	0	- 8	8	6	10	5	3	2
<b>30</b>	<b>50</b>	0	- 12	0	-10	9	8	10	6	3	2
<b>50</b>	<b>80</b>	0	- 15	0	-12	11	9	10	7	4	3
<b>80</b>	<b>120</b>	0	- 20	0	-15	15	11	15	8	4	3
<b>120</b>	<b>180</b>	0	- 25	0	-18	19	14	15	9	5	4
<b>180</b>	<b>250</b>	0	- 30	0	-22	23	17	20	10	5	4
<b>250</b>	<b>315</b>	0	- 35	0	-25	26	19	25	13	7	5
<b>315</b>	<b>400</b>	0	- 40	0	-30	30	23	30	15	7	5
<b>400</b>	<b>500</b>	0	- 45	0	-35	34	26	30	18	9	6
<b>500</b>	<b>630</b>	0	- 50	0	-40	38	30	35	21	11	7
<b>630</b>	<b>800</b>	0	- 75	0	-50	—	—	40	25	13	8
<b>800</b>	<b>1 000</b>	0	-100	—	—	—	—	45	30	15	—
<b>1 000</b>	<b>1 250</b>	0	-125	—	—	—	—	50	35	18	—

Note (°) For double-direction bearings, the thickness variation doesn't depend on the bore diameter  $d_2$ , but on  $d$  for single-direction bearings with the same  $D$  in the same diameter series. The thickness variation of housing washers,  $S_e$ , applies only to flat-seat thrust bearings.

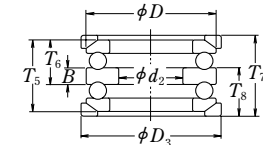
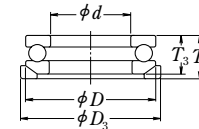
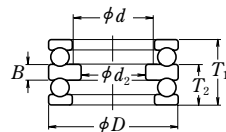
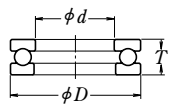

Table 8. 6. 2 Tolerances for Outside Diameter of Housing Washers and Aligning Seat Washers

Units :  $\mu\text{m}$

Nominal Outside Diameter of Bearing or Aligning Seat Washer $D$ or $D_3$ (mm)		$\Delta_{Dmp}$						$V_{Dp}$		Aligning Seat Washer Outside Diameter Deviation $\Delta_{D_{3s}}$	
		Flat Seat Type				Aligning Seat Washer Type					
		over	incl	high	low	high	low	high	low	Normal Class 6 Class 5	Class 4
<b>10</b>	<b>18</b>	0	- 11	0	- 7	0	- 17	8	5	0	- 25
<b>18</b>	<b>30</b>	0	- 13	0	- 8	0	- 20	10	6	0	- 30
<b>30</b>	<b>50</b>	0	- 16	0	- 9	0	- 24	12	7	0	- 35
<b>50</b>	<b>80</b>	0	- 19	0	-11	0	- 29	14	8	0	- 45
<b>80</b>	<b>120</b>	0	- 22	0	-13	0	- 33	17	10	0	- 60
<b>120</b>	<b>180</b>	0	- 25	0	-15	0	- 38	19	11	0	- 75
<b>180</b>	<b>250</b>	0	- 30	0	-20	0	- 45	23	15	0	- 90
<b>250</b>	<b>315</b>	0	- 35	0	-25	0	- 53	26	19	0	-105
<b>315</b>	<b>400</b>	0	- 40	0	-28	0	- 60	30	21	0	-120
<b>400</b>	<b>500</b>	0	- 45	0	-33	0	- 68	34	25	0	-135
<b>500</b>	<b>630</b>	0	- 50	0	-38	0	- 75	38	29	0	-180
<b>630</b>	<b>800</b>	0	- 75	0	-45	0	-113	55	34	0	-225
<b>800</b>	<b>1 000</b>	0	-100	—	—	—	—	75	—	—	—
<b>1 000</b>	<b>1 250</b>	0	-125	—	—	—	—	—	—	—	—
<b>1 250</b>	<b>1 600</b>	0	-160	—	—	—	—	—	—	—	—

Table 8. 6. 3 Tolerances for Thrust Ball Bearing Height and Central Washer Height

Units :  $\mu\text{m}$

Nominal Bore Diameter $d$ (*) (mm)	Flat Seat Type				Aligning Seat Washer Type				With Aligning Seat Washer				Height Deviation of Central Washer $\Delta_{Bs}$		
	$\Delta_{T_s}$ or $\Delta_{T_{2s}}$		$\Delta_{T_{1s}}$		$\Delta_{T_{3s}}$ or $\Delta_{T_{6s}}$		$\Delta_{T_{5s}}$		$\Delta_{T_{4s}}$ or $\Delta_{T_{8s}}$		$\Delta_{T_{7s}}$				
	Normal, Class 6 Class 5, Class 4		Normal, Class 6 Class 5, Class 4		Normal Class 6		Normal Class 6		Normal Class 6		Normal Class 6		Normal, Class 6 Class 5, Class 4		
over	incl	high	low	high	low	high	low	high	low	high	low	high	low	high	low
—	30	0	-75	+50	-150	0	-75	+50	-150	+50	-75	+150	-150	0	-50
30	50	0	-100	+75	-200	0	-100	+75	-200	+50	-100	+175	-200	0	-75
50	80	0	-125	+100	-250	0	-125	+100	-250	+75	-125	+250	-250	0	-100
80	120	0	-150	+125	-300	0	-150	+125	-300	+75	-150	+275	-300	0	-125
120	180	0	-175	+150	-350	0	-175	+150	-350	+100	-175	+350	-350	0	-150
180	250	0	-200	+175	-400	0	-200	+175	-400	+100	-200	+375	-400	0	-175
250	315	0	-225	+200	-450	0	-225	+200	-450	+125	-225	+450	-450	0	-200
315	400	0	-300	+250	-600	0	-300	+250	-600	+150	-275	+550	-550	0	-250

Note (\*) For double-direction bearings, its classification depends on  $d$  for single-direction bearings with the same  $D$  in the same diameter series.

Remarks  $\Delta_{T_s}$  in the table is the deviation in the respective heights  $T$  in figures below.

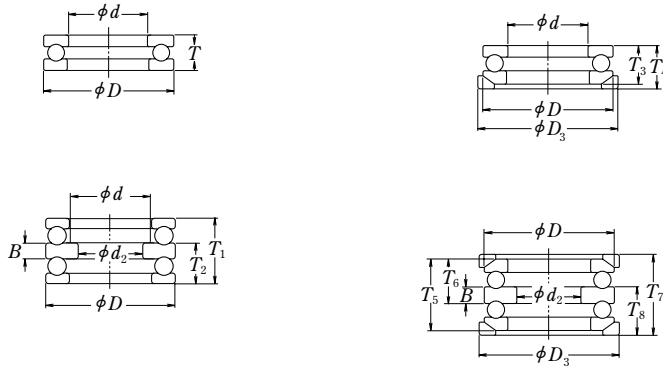

Table 8. 7 Tolerances for Spherical Thrust Roller Bearings

Table 8. 7. 1 Tolerances for Bore Diameters of Shaft Rings and Height (Class Normal)

Units :  $\mu\text{m}$

Nominal Bore Diameter $d$ (mm)	$\Delta_{dmp}$	$V_{dp}$	Reference				
			$S_d$		$\Delta_{T_s}$		
over	incl	high	low	max	max	high	low
50	80	0	-15	11	25	+150	-150
80	120	0	-20	15	25	+200	-200
120	180	0	-25	19	30	+250	-250
180	250	0	-30	23	30	+300	-300
250	315	0	-35	26	35	+350	-350
315	400	0	-40	30	40	+400	-400
400	500	0	-45	34	45	+450	-450

Remarks The bore diameter "no-go side" tolerances (high) specified in this table do not necessarily apply within a distance of 1.2 times the chamfer dimension  $r$  (max) from the ring face.

Table 8. 7. 2 Tolerances for Housing Ring Diameter (Class Normal)

Units :  $\mu\text{m}$

Nominal Outside Diameter $D$ (mm)		$\Delta_{Dmp}$	
over	incl	high	low
120	180	0	-25
180	250	0	-30
250	315	0	-35
315	400	0	-40
400	500	0	-45
500	630	0	-50
630	800	0	-75
800	1 000	0	-100

Remarks The outside diameter "no-go side" tolerances (low) specified in this table do not necessarily apply within a distance of 1.2 times the chamfer dimension  $r$  (max) from the ring face.

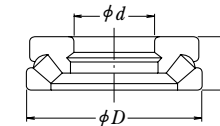



**Table 8. 8 Tolerances of CLASS 5P, CLASS 7P, and CLASS 9P**

**(1) Tolerances for Inner Rings**

Nominal Bore Diameter $d$ (mm)		$\Delta_{dmp}$				$\Delta_{ds}$				$V_{dp}$		$V_{dmp}$		$\Delta_{Bs}$	
		CLASS 5P CLASS 7P		CLASS 9P		CLASS 5P CLASS 7P		CLASS 9P		CLASS 5P CLASS 7P	CLASS 9P	CLASS 5P CLASS 7P	CLASS 9P	Single Brgs	
		CLASS 5P	CLASS 7P	CLASS 9P	CLASS 9P	CLASS 5P	CLASS 7P	CLASS 9P	CLASS 9P	max	max	max	max	high	low
over	incl	high	low	high	low	high	low	high	low	max	max	max	max	high	low
—	10	0	-5.1	0	-2.5	0	-5.1	0	-2.5	2.5	1.3	2.5	1.3	0	-25.4
10	18	0	-5.1	0	-2.5	0	-5.1	0	-2.5	2.5	1.3	2.5	1.3	0	-25.4
18	30	0	-5.1	0	-2.5	0	-5.1	0	-2.5	2.5	1.3	2.5	1.3	0	-25.4

**Note** (1) Applicable to bearings for which the axial clearance (preload) is to be adjusted by combining two selected bearings.  
**Remarks** For the CLASS 3P and the tolerances of Metric design Instrument Ball Bearings, it is advisable to consult NSK.

**(2) Tolerances for**

Nominal Outside Diameter $D$ (mm)		$\Delta_{Dmp}$				$\Delta_{Ds}$				$V_{Dp}$			$V_{Dmp}$			
		CLASS 5P CLASS 7P		CLASS 9P		CLASS 5P CLASS 7P		CLASS 9P	CLASS 5P CLASS 7P	CLASS 9P	CLASS 5P CLASS 7P	CLASS 9P	CLASS 9P			
		Open	Shielded Sealed	Open	Shielded Sealed	Open	Shielded Sealed	Open	Open	Shielded Sealed	Open	Open	Shielded Sealed	Open		
over	incl	high	low	high	low	high	low	high	low	max	max	max	max	max	max	
—	18	0	-5.1	0	-2.5	0	-5.1	+1	-6.1	0	-2.5	2.5	5.1	1.3	2.5	5.1
18	30	0	-5.1	0	-3.8	0	-5.1	+1	-6.1	0	-3.8	2.5	5.1	2	2.5	5.1
30	50	0	-5.1	0	-3.8	0	-5.1	+1	-6.1	0	-3.8	2.5	5.1	2	2.5	5.1

**Notes** (1) Applicable to flange width variation for flanged bearings.  
 (2) Applicable to flange back face.

**Instrument Ball Bearings (Inch design)**

(ANSI/ABMA Equivalent)

**and Width of Outer Rings**

Units :  $\mu\text{m}$

(or $\Delta_{Cs}$ )		$V_{Bs}$			$K_{ia}$			$S_{ia}$			$S_d$		
Combined Brgs (1)		CLASS 5P	CLASS 7P	CLASS 9P	CLASS 5P	CLASS 7P	CLASS 9P	CLASS 5P	CLASS 7P	CLASS 9P	CLASS 5P	CLASS 7P	CLASS 9P
high	low	max	max	max	max	max	max	max	max	max	max	max	max
0	-400	5.1	2.5	1.3	3.8	2.5	1.3	7.6	2.5	1.3	7.6	2.5	1.3
0	-400	5.1	2.5	1.3	3.8	2.5	1.3	7.6	2.5	1.3	7.6	2.5	1.3
0	-400	5.1	2.5	1.3	3.8	3.8	2.5	7.6	3.8	1.3	7.6	3.8	1.3

**Outer Rings**

Units :  $\mu\text{m}$

$V_{Cs}$ (1)			$S_D$			$K_{ea}$			$S_{ea}$			Deviation of Flange Outside Diameter $\Delta_{D1s}$		Deviation of Flange Width $\Delta_{C1s}$		Flange Backface Runout with Raceway (2) $S_{ea1}$
CLASS 5P	CLASS 7P	CLASS 9P	CLASS 5P	CLASS 7P	CLASS 9P	CLASS 5P	CLASS 7P	CLASS 9P	CLASS 5P	CLASS 7P	CLASS 9P	CLASS 5P	CLASS 7P	CLASS 5P	CLASS 7P	CLASS 5P
max	max	max	max	max	max	max	max	max	max	max	max	high	low	high	low	max
5.1	2.5	1.3	7.6	3.8	1.3	5.1	3.8	1.3	7.6	5.1	1.3	0	-25.4	0	-50.8	7.6
5.1	2.5	1.3	7.6	3.8	1.3	5.1	3.8	2.5	7.6	5.1	2.5	0	-25.4	0	-50.8	7.6
5.1	2.5	1.3	7.6	3.8	1.3	5.1	5.1	2.5	7.6	5.1	2.5	0	-25.4	0	-50.8	7.6

Table 8.9 Chamfer Dimension Limits (for Metric Design Bearings)

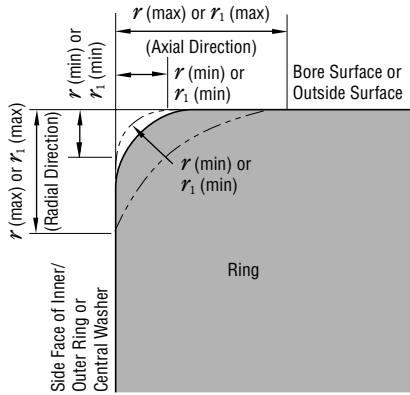

$r$  : Chamfer Dimension of Inner/Outer Ring  
 $r_1$  : Chamfer Dimension of Inner/Outer Ring (Front Side) or of Central Washer of Thrust Ball Bearings

**Remarks** The precise shape of chamfer surfaces has not been specified but its profile in the axial plane shall not intersect an arc of radius  $r$  (min) or  $r_1$  (min) touching the side face of an inner ring or central washer and bore surface, or the side face of an outer ring and outside surface.

Table 8.9.1 Chamfer Dimension Limits for Radial Bearings (excluding Tapered Roller Bearings)

Permissible Chamfer Dimension for Inner/Outer Rings $r$ (min) or $r_1$ (min)	Nominal Bore Diameter $d$		Permissible Chamfer Dimension for Inner/Outer Rings $r$ (max) or $r_1$ (max)		Reference Corner Radius of Shaft or Housing $r_a$ max
	over	incl	Radial Direction	Axial Direction	
	Units : mm				
0.05	—	—	0.1	0.2	0.05
0.08	—	—	0.16	0.3	0.08
0.1	—	—	0.2	0.4	0.1
0.15	—	—	0.3	0.6	0.15
0.2	—	—	0.5	0.8	0.2
0.3	—	40	0.6	1	0.3
	40	—	0.8	1	
0.6	—	40	1	2	0.6
	40	—	1.3	2	
1	—	50	1.5	3	1
	50	—	1.9	3	
1.1	—	120	2	3.5	1
	120	—	2.5	4	
1.5	—	120	2.3	4	1.5
	120	—	3	5	
2	—	80	3	4.5	2
	80	220	3.5	5	
	220	—	3.8	6	
2.1	—	280	4	6.5	2
	280	—	4.5	7	
2.5	—	100	3.8	6	2
	100	280	4.5	6	
	280	—	5	7	
3	—	280	5	8	2.5
	280	—	5.5	8	
4	—	—	6.5	9	3
5	—	—	8	10	4
6	—	—	10	13	5
7.5	—	—	12.5	17	6
9.5	—	—	15	19	8
12	—	—	18	24	10
15	—	—	21	30	12
19	—	—	25	38	15

**Remarks** For bearings with nominal widths less than 2mm, the value of  $r$  (max) in the axial direction is the same as that in the radial direction.

Table 8.9.2 Chamfer Dimension Limits for Tapered Roller Bearings

Permissible Chamfer Dimension for Inner/Outer Rings $r$ (min)	Nominal Bore or Nominal Outside Diameter $d$ or $D$		Permissible Chamfer Dimension for Inner/Outer Rings $r$ (max)		Reference Corner Radius of Shaft or Housing $r_a$ max
	over	incl	Radial Direction	Axial Direction	
	Units : mm				
0.15	—	—	0.3	0.6	0.15
0.3	—	40	0.7	1.4	0.3
	40	—	0.9	1.6	
0.6	—	40	1.1	1.7	0.6
	40	—	1.3	2	
1	—	50	1.6	2.5	1
	50	—	1.9	3	
1.5	—	120	2.3	3	1.5
	120	250	2.8	3.5	
	250	—	3.5	4	
2	—	120	2.8	4	2
	120	250	3.5	4.5	
	250	—	4	5	
2.5	—	120	3.5	5	2
	120	250	4	5.5	
	250	—	4.5	6	
3	—	120	4	5.5	2.5
	120	250	4.5	6.5	
	250	400	5	7	
	400	—	5.5	7.5	
4	—	120	5	7	3
	120	250	5.5	7.5	
	250	400	6	8	
	400	—	6.5	8.5	
5	—	180	6.5	8	4
	180	—	7.5	9	
6	—	180	7.5	10	5
	180	—	9	11	

**Note** <sup>(1)</sup> Inner Rings are classified by  $d$  and Outer Rings by  $D$ .

Table 8.9.3 Chamfer Dimension Limits for Thrust Bearings

Permissible Chamfer Dimension for Shaft (or Central)/Housing Washers $r$ (min) or $r_1$ (min)	Permissible Chamfer Dimension for Shaft (or Central)/Housing Washers $r$ (max) or $r_1$ (max)		Reference Corner Radius of Shaft or Housing $r_a$ max
	Radial or Axial Direction		
	Units : mm		
0.05	0.1		0.05
0.08	0.16		0.08
0.1	0.2		0.1
0.15	0.3		0.15
0.2	0.5		0.2
0.3	0.8		0.3
0.6	1.5		0.6
1	2.2		1
1.1	2.7		1
1.5	3.5		1.5
2	4		2
2.1	4.5		2
3	5.5		2.5
4	6.5		3
5	8		4
6	10		5
7.5	12.5		6
9.5	15		8
12	18		10
15	21		12
19	25		15

Table 8.10 Tolerances for Tapered Bores (Class Normal)

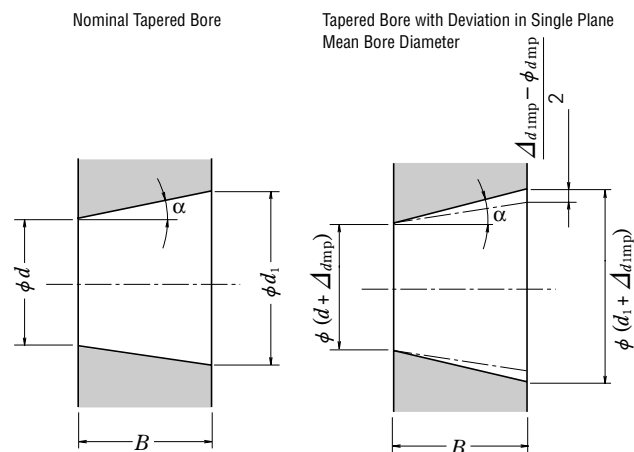

$d$ : Nominal Bore Diameter  
 $d_1$ : Theoretical Diameter of Larger End of Tapered Bore  
 Taper 1:12  $d_1 = d + 1/12 B$       Taper 1:30  $d_1 = d + /30 B$   
 $\Delta_{d1mp}$ : Single Plane Mean Bore Diameter Deviation in Theoretical Diameter of Smaller End of Bore  
 $\Delta_{d1mp}$ : Single Plane Mean Bore Diameter Deviation in Theoretical Diameter of Larger End of Bore  
 $V_{dp}$ : Bore diameter variation in a single radial plane  
 $B$ : Nominal Inner Ring width  
 $\alpha$ : Half of Taper Angle of Tapered Bore

Taper 1:12  
 $\alpha = 2^\circ 23' 9.4''$   
 $= 2.38594^\circ$   
 $= 0.041643 \text{ rad}$

Taper 1:30  
 $\alpha = 57' 17.4''$   
 $= 0.95484^\circ$   
 $= 0.016665 \text{ rad}$

Taper 1 : 12

Units :  $\mu\text{m}$

Nominal Bore Diameter $d$ (mm)		$\Delta_{dmp}$		$\Delta_{d1mp} - \Delta_{dmp}$		$V_{dp}$ (°) (°)
over	incl	high	low	high	low	max
18	30	+33	0	+21	0	13
30	50	+39	0	+25	0	16
50	80	+46	0	+30	0	19
80	120	+54	0	+35	0	22
120	180	+63	0	+40	0	40
180	250	+72	0	+46	0	46
250	315	+81	0	+52	0	52
315	400	+89	0	+57	0	57
400	500	+97	0	+63	0	63
500	630	+110	0	+70	0	70
630	800	+125	0	+80	0	—
800	1 000	+140	0	+90	0	—
1 000	1 250	+165	0	+105	0	—
1 250	1 600	+195	0	+125	0	—

Notes (1) Applicable to all radial planes of tapered bores.  
 (2) Not applicable to diameter series 7 and 8.

Taper 1 : 30

Units :  $\mu\text{m}$

Nominal Bore Diameter $d$ (mm)		$\Delta_{dmp}$		$\Delta_{d1mp} - \Delta_{dmp}$		$V_{dp}$ (°) (°)
over	incl	high	low	high	low	max
80	120	+20	0	+35	0	22
120	180	+25	0	+40	0	40
180	250	+30	0	+46	0	46
250	315	+35	0	+52	0	52
315	400	+40	0	+57	0	57
400	500	+45	0	+63	0	63
500	630	+50	0	+70	0	70

Notes (1) Applicable to all radial planes of tapered bores.  
 (2) Not applicable to diameter series 7 and 8.

Remarks For a value exceeding 630 mm, please contact NSK.

### 8.2 Selection of Accuracy Classes

For general applications, Class Normal tolerances are adequate in nearly all cases for satisfactory performance, but for the following applications, bearings having an accuracy class of 5, 4 or higher are more suitable.

For reference, in Table 8.11, examples of applications and appropriate tolerance classes are listed for various bearing requirements and operating conditions.

Table 8.11 Typical Tolerance Classes for Specific Applications (Reference)

Bearing Requirement, Operating Conditions	Examples of Applications	Tolerance Classes
High running accuracy is required	VTR Drum Spindles	P5
	Magnetic Disk Spindles for Computers	P5, P4, P2
	Machine-Tool Main Spindles	P5, P4, P2
	Rotary Printing Presses	P5
	Rotary Tables of Vertical Presses, etc.	P5, P4
	Roll Necks of Cold Rolling Mill Backup Rolls	Higher than P4
Extra high speed is required	Slewing Bearings for Parabolic Antennas	Higher than P4
	Dental Drills	CLASS 7P, CLASS 5P
	Gyroscopes	CLASS 7P, P4
	High Frequency Spindles	CLASS 7P, P4
	Superchargers	P5, P4
	Centrifugal Separators	P5, P4
Low torque and low torque variation are required	Main Shafts of Jet Engines	Higher than P4
	Gyroscope Gimbals	CLASS 7P, P4
	Servomechanisms	CLASS 7P, CLASS 5P
Potentiometric Controllers	CLASS 7P	

# 9. FITS AND INTERNAL CLEARANCES

## 9.1 Fits

### 9.1.1 Importance of Proper Fits

In the case of a rolling bearing with the inner ring fitted to the shaft with only slight interference, a harmful circumferential slipping may occur between the inner ring and shaft. This slipping of the inner ring, which is called "creep", results in a circumferential displacement of the ring relative to the shaft if the interference fit is not sufficiently tight. When creep occurs, the fitted surfaces become abraded, causing wear and considerable damage to the shaft. Abnormal heating and vibration may also occur due to abrasive metallic particles entering the interior of the bearing. It is important to prevent creep by having sufficient interference to firmly secure that ring which rotates to either the shaft or housing. Creep cannot always be eliminated using only axial tightening through the bearing ring faces. Generally, it is not necessary, however, to provide interference for rings subjected only to stationary loads. Fits are sometimes made without any interference for either the inner or outer ring, to accommodate certain operating conditions, or to facilitate mounting and dismounting. In this case, to prevent damage to the fitting surfaces due to creep, lubrication of other applicable methods should be considered.

### 9.1.2 Selection of Fit

#### (1) Load Conditions and Fit

The proper fit may be selected from Table 9.1 based on the load and operating conditions.

#### (2) Magnitude of Load and Interference

The interference of the inner ring is slightly reduced by the bearing load; therefore, the loss of interference should be estimated using the following equations:

$$\left. \begin{aligned} \Delta d_F &= 0.08 \sqrt{\frac{d}{B}} F_r \times 10^{-3} \dots\dots (N) \\ \Delta d_F &= 0.25 \sqrt{\frac{d}{B}} F_r \times 10^{-3} \dots\dots \{kgf\} \end{aligned} \right\} \dots\dots (9.1)$$

where  $\Delta d_F$  : Interference decrease of inner ring (mm)  
 $d$  : Bearing bore diameter (mm)  
 $B$  : Nominal inner ring width (mm)  
 $F_r$  : Radial load applied on bearing (N), {kgf}

Therefore, the effective interference  $\Delta d$  should be larger than the interference given by Equation (9.1). However, in the case of heavy loads where the radial load exceeds 20% of the basic static load rating  $C_{0r}$ , under the operating condition, interference often becomes shortage. Therefore, interference should be estimated using Equation (9.2):

$$\left. \begin{aligned} \Delta d &\geq 0.02 \frac{F_r}{B} \times 10^{-3} \dots\dots (N) \\ \Delta d &\geq 0.2 \frac{F_r}{B} \times 10^{-3} \dots\dots \{kgf\} \end{aligned} \right\} \dots\dots (9.2)$$

where  $\Delta d$  : Effective interference (mm)  
 $F_r$  : Radial load applied on bearing (N), {kgf}  
 $B$  : Nominal inner ring width (mm)

#### (3) Interference Variation Caused by Temperature Difference between Bearing and Shaft or Housing

The effective interference decreases due to the increasing bearing temperature during operation. If the temperature difference between the bearing and housing is  $\Delta T$  (°C), then the temperature difference between the fitted surfaces of the shaft and inner ring is estimated to be about (0.1~0.15)  $\Delta T$  in case that the shaft is cooled. The decrease in the interference of the inner ring due to this temperature difference  $\Delta d_T$  may be calculated using Equation (9.3):

$$\Delta d_T = (0.10\text{--}0.15) \times \Delta T \cdot \alpha \cdot d \approx 0.0015 \Delta T \cdot d \times 10^{-3} \dots\dots (9.3)$$

where  $\Delta d_T$  : Decrease in interference of inner ring due to temperature difference (mm)  
 $\Delta T$  : Temperature difference between bearing interior and surrounding parts (°C)  
 $\alpha$  : Coefficient of linear expansion of bearing steel =  $12.5 \times 10^{-6}$  (1/°C)  
 $d$  : Bearing nominal bore diameter (mm)

In addition, depending on the temperature difference between the outer ring and housing, or difference in their coefficients of linear expansion, the interference may increase.

#### (4) Effective Interference and Finish of Shaft and Housing

Since the roughness of fitted surfaces is reduced during fitting, the effective interference becomes less than the apparent interference. The amount of this interference decrease varies depending on the

roughness of the surfaces and may be estimated using the following equations:

For ground shafts  $\Delta d = \frac{d}{d+2} \Delta d_a \dots\dots (9.4)$

For machined shafts  $\Delta d = \frac{d}{d+3} \Delta d_a \dots\dots (9.5)$

where  $\Delta d$  : Effective interference (mm)  
 $\Delta d_a$  : Apparent interference (mm)  
 $d$  : Bearing nominal bore diameter (mm)

According to Equations (9.4) and (9.5), the effective interference of bearings with a bore diameter of 30 to 150 mm is about 95% of the apparent interference.

#### (5) Fitting Stress and Ring Expansion and Contraction

When bearings are mounted with interference on a shaft or in a housing, the rings either expand or contract and stress is produced. Excessive interference may damage the bearings; therefore, as a general guide, the maximum interference should be kept under approximately 7/10 000 of the shaft diameter. The pressure between fitted surfaces, expansion or contraction of the rings, and circumferential stress may be calculated using the equations in Section 15.2, Fitting(1) (Pages A130 and 131).

### 9.1.3 Recommended Fits

As described previously, many factors, such as the characteristics and magnitude of bearing load, temperature differences, means of bearing mounting and dismounting, must be considered when selecting the proper fit. If the housing is thin or the bearing is mounted on a hollow shaft, a tighter than usual fit is necessary. A split housing often deforms the bearing into an oval shape; therefore, a split housing should be avoided when a tight fit with the outer ring is required. The fits of both the inner and outer rings should be tight in applications where the shaft is subjected to considerable vibration. The recommended fits for some common applications are shown in Table 9.2 to 9.7. In the case of unusual operating conditions, it is advisable to consult NSK. For the accuracy and surface finish of shafts and housings, please refer to Section 11.1 (Page A100).

Table 9.1 Loading Conditions and Fits

Load Application	Bearing Operation		Load Conditions	Fitting	
	Inner Ring	Outer Ring		Inner Ring	Outer Ring
	Rotating	Stationary	Rotating Inner Ring Load	Tight Fit	Loose Fit
	Stationary	Rotating	Stationary Outer Ring Load	Tight Fit	Loose Fit
	Stationary	Rotating	Rotating Outer Ring Load	Loose Fit	Tight Fit
	Rotating	Stationary	Stationary Inner Ring Load	Loose Fit	Tight Fit
Direction of load indeterminate due to variation of direction or unbalanced load	Rotating or Stationary	Rotating or Stationary	Direction of Load Indeterminate	Tight Fit	Tight Fit

Table 9.2 Fits of Radial Bearings with Shafts

Load Conditions	Examples	Shaft Diameter (mm)			Tolerance of Shaft	Remarks	
		Ball Brgs	Cylindrical Roller Brgs, Tapered Roller Brgs	Spherical Roller Brgs			
<b>Radial Bearings with Cylindrical Bores</b>							
Rotating Outer Ring Load	Easy axial displacement of inner ring on shaft desirable.	Wheels on Stationary Axles	All Shaft Diameters			g6	Use g5 and h5 where accuracy is required. In case of large bearings, f6 can be used to allow easy axial movement.
	Easy axial displacement of inner ring on shaft unnecessary	Tension Pulleys Rope Sheaves				h6	
Rotating Inner Ring Load or Direction of Load Indeterminate	Light Loads or Variable Loads (<0.06C <sub>r</sub> <sup>(1)</sup> )	Electrical Home Appliances Pumps, Blowers, Transport Vehicles, Precision Machinery, Machine Tools	<18	—	—	js5	k6 and m6 can be used for single-row tapered roller bearings and single-row angular contact ball bearings instead of k5 and m5.
			18~100	<40	—	js6(j6)	
			100~200	40~140	—	k6	
	Normal Loads (0.06 to 0.13C <sub>r</sub> <sup>(1)</sup> )	General Bearing Applications, Medium and Large Motors, Turbines, Pumps, Engine Main Bearings, Gears, Woodworking Machines	<18	—	—	js5-6 (j5-6)	
			18~100	<40	<40	k5-6	
			100~140	40~100	40~65	m5-6	
			140~200	100~140	65~100	m6	
			200~280	140~200	100~140	n6	
			—	200~400	140~280	p6	
			—	—	280~500	r6	
Heavy Loads or Shock Loads (>0.13C <sub>r</sub> <sup>(1)</sup> )	Railway Axleboxes, Industrial Vehicles, Traction Motors, Construction Equipment, Crushers	—	50~140	50~100	n6	More than CN bearing internal clearance is necessary.	
		—	140~200	100~140	p6		
		—	over 200	140~200	r6		
		—	—	200~500	r7		
Axial Loads Only		All Shaft Diameters		js6 (j6)	—		
<b>Radial Bearings with Tapered Bores and Sleeves</b>							
All Types of Loading	General bearing Applications Railway Axleboxes Transmission Shafts, Woodworking Spindles	All Shaft Diameters			h9/IT5	IT5 and IT7 mean that the deviation of the shaft from its true geometric form, e. g. roundness and cylindricity should be within the tolerances of IT5 and IT7 respectively.	
					h10/IT7		

Note <sup>(1)</sup> C<sub>r</sub> represents the basic load rating of the bearing.

Remarks This table is applicable only to solid steel shafts.

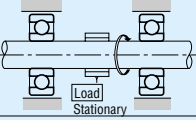
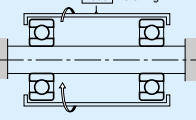
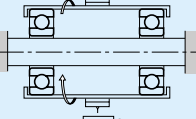
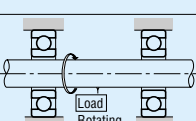
Table 9.3 Fits of Thrust Bearings with Shafts

Load Conditions	Examples	Shaft Diameter (mm)	Tolerance of Shaft	Remarks	
Central Axial Load Only	Main Shafts of Lathes	All Shaft Diameters	h6 or js6 (j6)	—	
Combined Radial and Axial Loads (Spherical Thrust Roller Bearings)	Stationary Inner Ring Load	Cone Crushers	js6 (j6)		
	Rotating Inner Ring Load or Direction of Load Indeterminate		<200		k6
			200~400		m6
		over 400	n6		

Table 9.4 Fits of Radial Bearings with Housings

Load Conditions		Examples	Tolerances for Housing Bores	Axial Displacement of Outer Ring	Remarks
Solid Housings	Rotating Outer Ring Load	Heavy Loads on Bearing in Thin-Walled Housing of Heavy Shock Loads	P7	Impossible	—
		Normal or Heavy Loads	N7		
	Light or Variable Loads	M7			
Solid or Split Housings	Direction of Load Indeterminate	Heavy Shock Loads	K7	Generally Impossible	If axial displacement of the outer ring is not required.
		Normal or Heavy Loads			
Solid or Split Housings	Rotating Inner Ring Load	Normal or Light Loads	JS7 (J7)	Possible	Axial displacement of outer ring is necessary.
		Loads of All kinds	H7	Easily possible	—
	Normal or Light Loads	H8			
Solid Housing	Direction of Load Indeterminate	High Temperature Rise of Inner Ring Through Shaft	G7	Possible	—
		Accurate Running Desirable under Normal or Light Loads	JS6 (j6)		
	Rotating Inner Ring Load	Accurate Running and High Rigidity Desirable under Variable Loads	K6	Generally Impossible	For heavy loads, interference fit tighter than K is used. When high accuracy is required, very strict tolerances should be used for fitting.
Solid Housing	Rotating Inner Ring Load	Grinding Spindle Rear Ball Bearings High Speed Centrifugal Compressor Free Bearings	M6 or N6	Impossible	—
		Grinding Spindle Front Ball Bearings High Speed Centrifugal Compressor Fixed Bearings	H6	Easily Possible	

Remarks This table is applicable to cast iron and steel housings. For housings made of light alloys, the interference should be tighter than those in this table.

Table 9.5 Fits of Thrust Bearings with Housings

Load Conditions	Bearing Types	Tolerances for Housing Bores	Remarks		
Axial Loads Only	Thrust Ball Bearings	Clearance over 0.25mm	For General Applications		
		H8	When precision is required		
Combined Radial and Axial Loads	Spherical Thrust Roller Bearings Steep Angle Tapered Roller Bearings	H7 or JS7 (J7)	Outer ring has radial clearance.		
			When radial loads are sustained by other bearings.		
Combined Radial and Axial Loads	Stationary Outer Ring Loads	Spherical Thrust Roller Bearings	—		
			Rotating Outer Ring Loads or Direction of Load Indeterminate	K7	Normal Loads
			M7	Relatively Heavy Radial Loads	

Table 9.6 Fits of Inch Design Tapered Roller Bearings with Shafts

(1) Bearings of Precision Classes 4 and 2

Units :  $\mu\text{m}$

Operating Conditions		Nominal Bore Diameters $d$				Bore Diameter Tolerances $\Delta d_s$		Shaft Diameter Tolerances		Remarks
		over		incl		high	low	high	low	
		(mm)	1/25.4	(mm)	1/25.4					
Rotating Inner Ring Loads	Normal Loads	—	—	76.200	3.0000	+13	0	+38	+25	For bearings with $d \leq 152.4\text{mm}$ , clearance is usually larger than CN.
		304.800	12.0000	609.600	24.0000	+25	0	+64	+38	
		609.600	24.0000	914.400	36.0000	+51	0	+127	+76	
Rotating Inner Ring Loads	Heavy Loads Shock Loads High Speeds	—	—	76.200	3.0000	+13	0	+64	+38	In general, bearings with a clearance larger than CN are used. ※ means that the average interference is about $0.0005 d$ .
		304.800	12.0000	609.600	24.0000	+25	0	※	※	
		609.600	24.0000	914.400	36.0000	+51	0	+381	+305	
Rotating Outer Ring Loads	Normal Loads without Shocks	—	—	76.200	3.0000	+13	0	+13	0	The inner ring cannot be displaced axially. When heavy or shock loads exist, the figures in the above (Rotating inner ring loads, heavy or shock loads) apply.
		304.800	12.0000	609.600	24.0000	+25	0	+25	0	
		609.600	24.0000	914.400	36.0000	+51	0	+51	0	
Rotating Outer Ring Loads	Normal Loads without Shocks	—	—	76.200	3.0000	+13	0	0	-13	The inner ring can be displaced axially.
		304.800	12.0000	609.600	24.0000	+25	0	0	-25	
		609.600	24.0000	914.400	36.0000	+51	0	0	-51	

(2) Bearings of Precision Classes 3 and 0 <sup>(1)</sup>

Units :  $\mu\text{m}$

Operating Conditions		Nominal Bore Diameters $d$				Bore Diameter Tolerances $\Delta d_s$		Shaft Diameter Tolerances		Remarks
		over		incl		high	low	high	low	
		(mm)	1/25.4	(mm)	1/25.4					
Rotating Inner Ring Loads	Precision Machine-Tool Main Spindles	—	—	76.200	3.0000	+13	0	+30	+18	—
		304.800	12.0000	609.600	24.0000	+13	0	+30	+18	
		609.600	24.0000	914.400	36.0000	+25	0	+64	+38	
Rotating Inner Ring Loads	Heavy Loads Shock Loads High Speeds	—	—	76.200	3.0000	+13	0	—	—	A minimum interference of about $0.00025 d$ is used.
		304.800	12.0000	609.600	24.0000	+13	0	—	—	
		609.600	24.0000	914.400	36.0000	+25	0	+38	0	
Rotating Outer Ring Loads	Precision Machine-Tool Main Spindles	—	—	76.200	3.0000	+13	0	+30	+18	—
		304.800	12.0000	609.600	24.0000	+13	0	+30	+18	
		609.600	24.0000	914.400	36.0000	+25	0	+64	+38	

Note <sup>(1)</sup> For bearings with  $d$  greater than 304.8mm, Class 0 does not exist.

Table 9.7 Fits of Inch Design Tapered Roller Bearings with Housings

(1) Bearings of Precision Classes 4 and 2

Units :  $\mu\text{m}$

Operating Conditions		Nominal Outside Diameters $D$				Outside Diameter Tolerances $\Delta D_s$		Housing Bore Diameter Tolerances		Remarks
		over		incl		high	low	high	low	
		(mm)	1/25.4	(mm)	1/25.4					
Rotating Inner Ring Loads	Used either on free-end or fixed-end	—	—	76.200	3.0000	+25	0	+76	+51	The outer ring can be easily displaced axially.
		304.800	12.0000	609.600	24.0000	+25	0	+76	+51	
		609.600	24.0000	914.400	36.0000	+51	0	+152	+102	
Rotating Inner Ring Loads	The outer ring position can be adjusted axially.	—	—	76.200	3.0000	+25	0	+25	0	The outer ring can be displaced axially.
		304.800	12.0000	609.600	24.0000	+25	0	+51	0	
		609.600	24.0000	914.400	36.0000	+25	0	+76	+25	
Rotating Inner Ring Loads	The outer ring position cannot be adjusted axially.	—	—	76.200	3.0000	+25	0	-13	-38	Generally, the outer ring is fixed axially.
		304.800	12.0000	609.600	24.0000	+25	0	-25	-51	
		609.600	24.0000	914.400	36.0000	+25	0	-25	-76	
Rotating Outer Ring Loads	Normal Loads The outer ring position cannot be adjusted axially.	—	—	76.200	3.0000	+25	0	-13	-38	The outer ring is fixed axially.
		304.800	12.0000	609.600	24.0000	+25	0	-25	-51	
		609.600	24.0000	914.400	36.0000	+51	0	-25	-76	

(2) Bearings of Precision Classes 3 and 0 <sup>(1)</sup>

Units :  $\mu\text{m}$

Operating Conditions		Nominal Outside Diameters $D$				Outside Diameter Tolerances $\Delta D_s$		Housing Bore Diameter Tolerances		Remarks
		over		incl		high	low	high	low	
		(mm)	1/25.4	(mm)	1/25.4					
Rotating Inner Ring Loads	Used on free-end	—	—	152.400	6.0000	+13	0	+38	+25	The outer ring can be easily displaced axially.
		304.800	12.0000	609.600	24.0000	+13	0	+64	+38	
		609.600	24.0000	914.400	36.0000	+25	0	+89	+51	
Rotating Inner Ring Loads	Used on fixed-end	—	—	152.400	6.0000	+13	0	+25	+13	The outer ring can be displaced axially.
		304.800	12.0000	609.600	24.0000	+13	0	+51	+25	
		609.600	24.0000	914.400	36.0000	+25	0	+76	+38	
Rotating Inner Ring Loads	The outer ring position can be adjusted axially.	—	—	152.400	6.0000	+13	0	+13	0	Generally, the outer ring is fixed axially.
		304.800	12.0000	609.600	24.0000	+13	0	+25	0	
		609.600	24.0000	914.400	36.0000	+25	0	+38	0	
Rotating Inner Ring Loads	The outer ring position cannot be adjusted axially.	—	—	152.400	6.0000	+13	0	0	-13	The outer ring is fixed axially.
		304.800	12.0000	609.600	24.0000	+13	0	0	-25	
		609.600	24.0000	914.400	36.0000	+25	0	0	-38	
Rotating Outer Ring Loads	Normal Loads The outer ring position cannot be adjusted axially.	—	—	76.200	3.0000	+13	0	-13	-25	The outer ring is fixed axially.
		304.800	12.0000	609.600	24.0000	+13	0	-13	-38	
		609.600	24.0000	914.400	36.0000	+25	0	-13	-38	

Note <sup>(1)</sup> For bearings with  $D$  greater than 304.8 mm, Class 0 does not exist.



9.2 Bearing Internal Clearances

9.2.1 Internal Clearances and Their Standards

The internal clearance in rolling bearings in operation greatly influences bearing performance including fatigue life, vibration, noise, heat-generation, etc. Consequently, the selection of the proper internal clearance is one of the most important tasks when choosing a bearing after the type and size have been determined.

This bearing internal clearance is the combined clearances between the inner/outer rings and rolling elements. The radial and axial clearances are defined as the total amount that one ring can be displaced relative to the other in the radial and axial directions respectively (Fig. 9.1).

To obtain accurate measurements, the clearance is generally measured by applying a specified measuring load on the bearing; therefore, the measured clearance (sometimes called "measured clearance" to make a distinction) is always slightly larger than the theoretical internal clearance (called "geometrical clearance" for radial bearings) by the amount of elastic deformation caused by the measuring load.

Therefore, the theoretical internal clearance may be obtained by correcting the measured clearance by the amount of elastic deformation. However, in the case of roller bearings this elastic deformation is negligibly small.

Usually the clearance before mounting is the one specified as the theoretical internal clearance.

In Table 9.8, reference table and page numbers are listed by bearing types.

Table 9.8 Index for Radial Internal Clearances by Bearing Types

Bearing Types	Table Number	Page Number	
Deep Groove Ball Bearings	9.9	A89	
Extra Small and Miniature Ball Bearings	9.10	A89	
Magneto Bearings	9.11	A89	
Self-Aligning Ball Bearings	9.12	A90	
Deep Groove Ball Bearings	9.13.1	A90	
For Motors			
Cylindrical Roller Bearings	9.13.2	A90	
Cylindrical Roller Bearings	With Cylindrical Bores	9.14	A91
	With Cylindrical Bores (Matched)		
	With Tapered Bores (Matched)		
Spherical Roller Bearings	With Cylindrical Bores	9.15	A92
	With Tapered Bores		
Double-Row and Combined Tapered Roller Bearings	9.15	A93	
Combined Angular Contact Ball Bearings (¹)	9.17	A94	
Four-Point Contact Ball Bearings (¹)	9.18	A94	

Note (¹) Values given are axial clearances.

Table 9.9 Radial Internal Clearances in Deep Groove Ball Bearings

Units : μm

Nominal Bore Diameter <i>d</i> (mm)	Clearance										
	C2		CN		C3		C4		C5		
	over	incl	min	max	min	max	min	max	min	max	
<b>10 only</b>		0	7	2	13	8	23	14	29	20	37
<b>10</b>	<b>18</b>	0	9	3	18	11	25	18	33	25	45
<b>18</b>	<b>24</b>	0	10	5	20	13	28	20	36	28	48
<b>24</b>	<b>30</b>	1	11	5	20	13	28	23	41	30	53
<b>30</b>	<b>40</b>	1	11	6	20	15	33	28	46	40	64
<b>40</b>	<b>50</b>	1	11	6	23	18	36	30	51	45	73
<b>50</b>	<b>65</b>	1	15	8	28	23	43	38	61	55	90
<b>65</b>	<b>80</b>	1	15	10	30	25	51	46	71	65	105
<b>80</b>	<b>100</b>	1	18	12	36	30	58	53	84	75	120
<b>100</b>	<b>120</b>	2	20	15	41	36	66	61	97	90	140
<b>120</b>	<b>140</b>	2	23	18	48	41	81	71	114	105	160
<b>140</b>	<b>160</b>	2	23	18	53	46	91	81	130	120	180
<b>160</b>	<b>180</b>	2	25	20	61	53	102	91	147	135	200
<b>180</b>	<b>200</b>	2	30	25	71	63	117	107	163	150	230
<b>200</b>	<b>225</b>	2	35	25	85	75	140	125	195	175	265
<b>225</b>	<b>250</b>	2	40	30	95	85	160	145	225	205	300
<b>250</b>	<b>280</b>	2	45	35	105	90	170	155	245	225	340
<b>280</b>	<b>315</b>	2	55	40	115	100	190	175	270	245	370
<b>315</b>	<b>355</b>	3	60	45	125	110	210	195	300	275	410
<b>355</b>	<b>400</b>	3	70	55	145	130	240	225	340	315	460
<b>400</b>	<b>450</b>	3	80	60	170	150	270	250	380	350	510
<b>450</b>	<b>500</b>	3	90	70	190	170	300	280	420	390	570
<b>500</b>	<b>560</b>	10	100	80	210	190	330	310	470	440	630
<b>560</b>	<b>630</b>	10	110	90	230	210	360	340	520	490	690
<b>630</b>	<b>710</b>	20	130	110	260	240	400	380	570	540	760
<b>710</b>	<b>800</b>	20	140	120	290	270	450	430	630	600	840

Remarks To obtain the measured values, use the clearance correction for radial clearance increase caused by the measuring load in the table below. For the C2 clearance class, the smaller value should be used for bearings with minimum clearance and the larger value for bearings near the maximum clearance range.

Units : μm

Nominal Bore Dia. <i>d</i> (mm)	Measuring Load (N) (kgf)	Radial Clearance Correction Amount				
		C2	CN	C3	C4	C5
over	incl					
<b>10 (incl)</b>	<b>18</b>	24.5	{2.5}	3~4	4	4
<b>18</b>	<b>50</b>	49	{5}	4~5	5	6
<b>50</b>	<b>280</b>	147	{15}	6~8	8	9

Remarks For values exceeding 280mm, please contact NSK.

Table 9.10 Radial Internal Clearances in Extra Small and Miniature Ball Bearings

Units : μm

Clearance Symbol	MC1	MC2	MC3	MC4	MC5	MC6
	min max	min max	min max	min max	min max	min max
Clearance	0 5	3 8	5 10	8 13	13 20	20 28

Remarks 1. The standard clearance is MC3.  
2. To obtain the measured value, add correction amount in the table below.

Units : μm

Clearance Symbol	MC1	MC2	MC3	MC4	MC5	MC6
Clearance Correction Value	1	1	1	1	2	2

The measuring loads are as follows :

For miniature ball bearings\* 2.5N {0.25kgf}

For extra small ball bearings\* 4.4N {0.45kgf}

\*For their classification, refer to Table 1 on Page B 31.

Table 9.11 Radial Internal Clearances in Magneto Bearings

Units : μm

Nominal Bore Diameter <i>d</i> (mm)	Bearing Series	Clearance	
		min	max
over	incl		
<b>2.5</b>	<b>30</b>	EN	10 50
		E	30 60

**Table 9.12 Radial Internal Clearances in Self-Aligning Ball Bearings**

Units :  $\mu\text{m}$

Nominal Bore Dia. $d$ (mm)		Clearance in Bearings with Cylindrical Bores					Clearance in Bearings with Tapered Bores												
		C2		CN	C3		C4		C5		C2	CN	C3		C4		C5		
over	incl	min	max	min	max	min	max	min	max	min	max	min	max	min	max	min	max	min	max
<b>2.5</b>	<b>6</b>	1	8	5	15	10	20	15	25	21	33	—	—	—	—	—	—	—	—
<b>6</b>	<b>10</b>	2	9	6	17	12	25	19	33	27	42	—	—	—	—	—	—	—	—
<b>10</b>	<b>14</b>	2	10	6	19	13	26	21	35	30	48	—	—	—	—	—	—	—	—
<b>14</b>	<b>18</b>	3	12	8	21	15	28	23	37	32	50	—	—	—	—	—	—	—	—
<b>18</b>	<b>24</b>	4	14	10	23	17	30	25	39	34	52	7	17	13	26	20	33	28	42
<b>24</b>	<b>30</b>	5	16	11	24	19	35	29	46	40	58	9	20	15	28	23	39	33	50
<b>30</b>	<b>40</b>	6	18	13	29	23	40	34	53	46	66	12	24	19	35	29	46	40	59
<b>40</b>	<b>50</b>	6	19	14	31	25	44	37	57	50	71	14	27	22	39	33	52	45	65
<b>50</b>	<b>65</b>	7	21	16	36	30	50	45	69	62	88	18	32	27	47	41	61	56	80
<b>65</b>	<b>80</b>	8	24	18	40	35	60	54	83	76	108	23	39	35	57	50	75	69	98
<b>80</b>	<b>100</b>	9	27	22	48	42	70	64	96	89	124	29	47	42	68	62	90	84	116
<b>100</b>	<b>120</b>	10	31	25	56	50	83	75	114	105	145	35	56	50	81	75	108	100	139
<b>120</b>	<b>140</b>	10	38	30	68	60	100	90	135	125	175	40	68	60	98	90	130	120	165
<b>140</b>	<b>160</b>	15	44	35	80	70	120	110	161	150	210	45	74	65	110	100	150	140	191

**Table 9.13 Radial Internal Clearances in Bearings for Electric Motors**

**Table 9.13.1 Deep Groove Ball Bearings for Electric Motors**

Units :  $\mu\text{m}$

Nominal Bore Dia. $d$ (mm)		Clearance		Remarks	
		CM		Recommended fit	
over	incl	min	max	Shaft	Housing Bore
<b>10 (incl)</b>	<b>18</b>	4	11	js5 (j5)	H6-7 or JS6-7 (J6-7)
<b>18</b>	<b>30</b>	5	12	k5	
<b>30</b>	<b>50</b>	9	17		
<b>50</b>	<b>80</b>	12	22		
<b>80</b>	<b>100</b>	18	30		
<b>100</b>	<b>120</b>	18	30		
<b>120</b>	<b>160</b>	24	38		

**Remarks** The radial clearance increase caused by the measuring load is equal to the correction amount for CN clearance in the remarks under Table 9.9.

**Table 9.13.2 Cylindrical Roller Bearings for Electric Motors**

Units :  $\mu\text{m}$

Nominal Bore Dia. $d$ (mm)		Clearance				Remarks		
		Interchangeable CT		Non-Interchangeable CM		Recommended Fit		
over	incl	min	max	min	max	Shaft	Housing Bore	
<b>24</b>	<b>40</b>	15	35	15	30	k5	JS6-7 (J6-7) or K6-7	
<b>40</b>	<b>50</b>	20	40	20	35	m5		
<b>50</b>	<b>65</b>	25	45	25	40			
<b>65</b>	<b>80</b>	30	50	30	45			
<b>80</b>	<b>100</b>	35	60	35	55			
<b>100</b>	<b>120</b>	35	65	35	60			
<b>120</b>	<b>140</b>	40	70	40	65			
<b>140</b>	<b>160</b>	50	85	50	80			
<b>160</b>	<b>180</b>	60	95	60	90			n6
<b>180</b>	<b>200</b>	65	105	65	100			

**Table 9.14 Radial Internal Clearances in Cylindrical Roller Bearings and Solid-Type Needle Roller Bearings**

Units :  $\mu\text{m}$

Nominal Bore Dia. $d$ (mm)		Clearances in Bearings with Cylindrical Bores					Clearances in Non-Interchangeable Bearings with Cylindrical Bores												
		C2		CN	C3		C4		C5		CC1	CC2	CC <sup>(1)</sup>	CC3	CC4	CC5			
over	incl	min	max	min	max	min	max	min	max	min	max	min	max	min	max	min	max	min	max
<b>10</b>	<b>24</b>	0	25	20	45	35	60	50	75	—	—	—	—	—	—	—	—	—	—
<b>24</b>	<b>30</b>	0	25	20	45	35	60	50	75	65	90	5	15	10	20	20	30	35	45
<b>30</b>	<b>40</b>	5	30	25	50	45	70	60	85	80	105	5	15	12	25	25	40	45	55
<b>40</b>	<b>50</b>	5	35	30	60	50	80	70	100	95	125	5	18	15	30	30	45	50	65
<b>50</b>	<b>65</b>	10	40	40	70	60	90	80	110	110	140	5	20	15	35	35	50	55	75
<b>65</b>	<b>80</b>	10	45	40	75	65	100	90	125	130	165	10	25	20	40	40	60	70	90
<b>80</b>	<b>100</b>	15	50	50	85	75	110	105	140	155	190	10	30	25	45	45	70	80	105
<b>100</b>	<b>120</b>	15	55	50	90	85	125	125	165	180	220	10	30	25	50	50	80	95	120
<b>120</b>	<b>140</b>	15	60	60	105	100	145	145	190	200	245	10	35	30	60	60	90	105	135
<b>140</b>	<b>160</b>	20	70	70	120	115	165	165	215	225	275	10	35	35	65	65	100	115	150
<b>160</b>	<b>180</b>	25	75	75	125	120	170	170	220	250	300	10	40	35	75	75	110	125	165
<b>180</b>	<b>200</b>	35	90	90	145	140	195	195	250	275	330	15	45	40	80	80	120	140	180
<b>200</b>	<b>225</b>	45	105	105	165	160	220	220	280	305	365	15	50	45	90	90	135	155	200
<b>225</b>	<b>250</b>	45	110	110	175	170	235	235	300	330	395	15	50	50	100	100	150	170	215
<b>250</b>	<b>280</b>	55	125	125	195	190	260	260	330	370	440	20	55	55	110	110	165	185	240
<b>280</b>	<b>315</b>	55	130	130	205	200	275	275	350	410	485	20	60	60	120	120	180	205	265
<b>315</b>	<b>355</b>	65	145	145	225	225	305	305	385	455	535	20	65	65	135	135	200	225	295
<b>355</b>	<b>400</b>	100	190	190	280	280	370	370	460	510	600	25	75	75	150	150	225	255	330
<b>400</b>	<b>450</b>	110	210	210	310	310	410	410	510	565	665	25	85	85	170	170	255	285	370
<b>450</b>	<b>500</b>	110	220	220	330	330	440	440	550	625	735	25	95	95	190	190	285	315	410

**Note** <sup>(1)</sup> CC denotes normal clearance for non-Interchangeable cylindrical roller bearings and solid-type needle roller bearings.

Units :  $\mu\text{m}$

Nominal Bore Dia. $d$ (mm)		Clearances in Non-Interchangeable Bearings with Tapered Bores															
		CC9 <sup>(1)</sup>		CC0		CC1		CC2		CC <sup>(2)</sup>		CC3		CC4		CC5	
over	incl	min	max	min	max	min	max	min	max	min	max	min	max	min	max	min	max
<b>10</b>	<b>24</b>	5	10	—	—	10	20	20	30	35	45	45	55	55	65	75	85
<b>24</b>	<b>30</b>	5	10	8	15	10	25	25	35	40	50	50	60	60	70	80	95
<b>30</b>	<b>40</b>	5	12	8	15	12	25	25	40	45	55	55	70	70	80	95	110
<b>40</b>	<b>50</b>	5	15	10	20	15	30	30	45	50	65	65	80	80	95	110	125
<b>50</b>	<b>65</b>	5	15	10	20	15	35	35	50	55	75	75	90	90	110	130	150
<b>65</b>	<b>80</b>	10	20	15	30	20	40	40	60	70	90	90	110	110	130	150	170
<b>80</b>	<b>100</b>	10	25	20	35	25	45	45	70	80	105	105	125	125	150	180	205
<b>100</b>	<b>120</b>	10	25	20	35	25	50	50	80	95	120	120	145	145	170	205	230
<b>120</b>	<b>140</b>	15	30	25	40	30	60	60	90	105	135	135	160	160	190	230	260
<b>140</b>	<b>160</b>	15	35	30	50	35	65	65	100	115	150	150	180	180	215	260	295
<b>160</b>	<b>180</b>	15	35	30	50	35	75	75	110	125	165	165	200	200	240	285	320
<b>180</b>	<b>200</b>	20	40	30	50	40	80	80	120	140	180	180	220	220	260	315	355
<b>200</b>	<b>225</b>	20	45	35	60	45	90	90	135	155	200	200	240	240	285	350	395
<b>225</b>	<b>250</b>	25	50	40	65	50	100	100	150	170	215	215	265	265	315	380	430
<b>250</b>	<b>280</b>	25	55	40	70	55	110	110	165	185	240	240	295	295	350	420	475
<b>280</b>	<b>315</b>	30	60	—	—	60	120	120	180	205	265	265	325	325	385	470	530
<b>315</b>	<b>355</b>	30	65	—	—	65	135	135	200	225	295	295	360	360	430	520	585
<b>355</b>	<b>400</b>	35	75	—	—												



Table 9.15 Radial Internal Clearances in Spherical Roller Bearings

Units :  $\mu\text{m}$

Nominal Bore Dia. $d$ (mm)		Clearance in Bearings with Cylindrical Bores										Clearance in Bearings with Tapered Bores									
		C2		CN		C3		C4		C5		C2		CN		C3		C4		C5	
over	incl	min	max	min	max	min	max	min	max	min	max	min	max	min	max	min	max	min	max	min	max
<b>24</b>	<b>30</b>	15	25	25	40	40	55	55	75	75	95	20	30	30	40	40	55	55	75	75	95
<b>30</b>	<b>40</b>	15	30	30	45	45	60	60	80	80	100	25	35	35	50	50	65	65	85	85	105
<b>40</b>	<b>50</b>	20	35	35	55	55	75	75	100	100	125	30	45	45	60	60	80	80	100	100	130
<b>50</b>	<b>65</b>	20	40	40	65	65	90	90	120	120	150	40	55	55	75	75	95	95	120	120	160
<b>65</b>	<b>80</b>	30	50	50	80	80	110	110	145	145	180	50	70	70	95	95	120	120	150	150	200
<b>80</b>	<b>100</b>	35	60	60	100	100	135	135	180	180	225	55	80	80	110	110	140	140	180	180	230
<b>100</b>	<b>120</b>	40	75	75	120	120	160	160	210	210	260	65	100	100	135	135	170	170	220	220	280
<b>120</b>	<b>140</b>	50	95	95	145	145	190	190	240	240	300	80	120	120	160	160	200	200	260	260	330
<b>140</b>	<b>160</b>	60	110	110	170	170	220	220	280	280	350	90	130	130	180	180	230	230	300	300	380
<b>160</b>	<b>180</b>	65	120	120	180	180	240	240	310	310	390	100	140	140	200	200	260	260	340	340	430
<b>180</b>	<b>200</b>	70	130	130	200	200	260	260	340	340	430	110	160	160	220	220	290	290	370	370	470
<b>200</b>	<b>225</b>	80	140	140	220	220	290	290	380	380	470	120	180	180	250	250	320	320	410	410	520
<b>225</b>	<b>250</b>	90	150	150	240	240	320	320	420	420	520	140	200	200	270	270	350	350	450	450	570
<b>250</b>	<b>280</b>	100	170	170	260	260	350	350	460	460	570	150	220	220	300	300	390	390	490	490	620
<b>280</b>	<b>315</b>	110	190	190	280	280	370	370	500	500	630	170	240	240	330	330	430	430	540	540	680
<b>315</b>	<b>355</b>	120	200	200	310	310	410	410	550	550	690	190	270	270	360	360	470	470	590	590	740
<b>355</b>	<b>400</b>	130	220	220	340	340	450	450	600	600	750	210	300	300	400	400	520	520	650	650	820
<b>400</b>	<b>450</b>	140	240	240	370	370	500	500	660	660	820	230	330	330	440	440	570	570	720	720	910
<b>450</b>	<b>500</b>	140	260	260	410	410	550	550	720	720	900	260	370	370	490	490	630	630	790	790	1000
<b>500</b>	<b>560</b>	150	280	280	440	440	600	600	780	780	1000	290	410	410	540	540	680	680	870	870	1100
<b>560</b>	<b>630</b>	170	310	310	480	480	650	650	850	850	1100	320	460	460	600	600	760	760	980	980	1230
<b>630</b>	<b>710</b>	190	350	350	530	530	700	700	920	920	1190	350	510	510	670	670	850	850	1090	1090	1360
<b>710</b>	<b>800</b>	210	390	390	580	580	770	770	1010	1010	1300	390	570	570	750	750	960	960	1220	1220	1500
<b>800</b>	<b>900</b>	230	430	430	650	650	860	860	1120	1120	1440	440	640	640	840	840	1070	1070	1370	1370	1690
<b>900</b>	<b>1000</b>	260	480	480	710	710	930	930	1220	1220	1570	490	710	710	930	930	1190	1190	1520	1520	1860
<b>1000</b>	<b>1120</b>	290	530	530	780	780	1020	1020	1330	—	—	530	770	770	1030	1030	1300	1300	1670	—	—
<b>1120</b>	<b>1250</b>	320	580	580	860	860	1120	1120	1460	—	—	570	830	830	1120	1120	1420	1420	1830	—	—
<b>1250</b>	<b>1400</b>	350	640	640	950	950	1240	1240	1620	—	—	620	910	910	1230	1230	1560	1560	2000	—	—

Table 9.16 Radial Internal Clearances in Double-Row and Combined Tapered Roller Bearings

Units :  $\mu\text{m}$

Nominal Bore Dia. $d$ (mm)		Clearance													
		C1		C2		CN		C3		C4		C5			
over	incl	min	max	min	max	min	max	min	max	min	max	min	max	min	max
—	<b>18</b>	0	10	10	20	20	30	35	45	50	60	65	75	—	—
<b>18</b>	<b>24</b>	0	10	10	20	20	30	35	45	50	60	65	75	—	—
<b>24</b>	<b>30</b>	0	10	10	20	20	30	40	50	50	60	70	80	—	—
<b>30</b>	<b>40</b>	0	12	12	25	25	40	45	60	60	75	80	95	—	—
<b>40</b>	<b>50</b>	0	15	15	30	30	45	50	65	65	80	95	110	—	—
<b>50</b>	<b>65</b>	0	15	15	35	35	55	60	80	80	100	110	130	—	—
<b>65</b>	<b>80</b>	0	20	20	40	40	60	70	90	90	110	130	150	—	—
<b>80</b>	<b>100</b>	0	25	25	50	50	75	80	105	105	130	155	180	—	—
<b>100</b>	<b>120</b>	5	30	30	55	55	80	90	115	120	145	180	210	—	—
<b>120</b>	<b>140</b>	5	35	35	65	65	95	100	130	135	165	200	230	—	—
<b>140</b>	<b>160</b>	10	40	40	70	70	100	110	140	150	180	220	260	—	—
<b>160</b>	<b>180</b>	10	45	45	80	80	115	125	160	165	200	250	290	—	—
<b>180</b>	<b>200</b>	10	50	50	90	90	130	140	180	180	220	280	320	—	—
<b>200</b>	<b>225</b>	20	60	60	100	100	140	150	190	200	240	300	340	—	—
<b>225</b>	<b>250</b>	20	65	65	110	110	155	165	210	220	270	330	380	—	—
<b>250</b>	<b>280</b>	20	70	70	120	120	170	180	230	240	290	370	420	—	—
<b>280</b>	<b>315</b>	30	80	80	130	130	180	190	240	260	310	410	460	—	—
<b>315</b>	<b>355</b>	30	80	80	130	140	190	210	260	290	350	450	510	—	—
<b>355</b>	<b>400</b>	40	90	90	140	150	200	220	280	330	390	510	570	—	—
<b>400</b>	<b>450</b>	45	95	95	145	170	220	250	310	370	430	560	620	—	—
<b>450</b>	<b>500</b>	50	100	100	150	190	240	280	340	410	470	620	680	—	—
<b>500</b>	<b>560</b>	60	110	110	160	210	260	310	380	450	520	700	770	—	—
<b>560</b>	<b>630</b>	70	120	120	170	230	290	350	420	500	570	780	850	—	—
<b>630</b>	<b>710</b>	80	130	130	180	260	310	390	470	560	640	870	950	—	—
<b>710</b>	<b>800</b>	90	140	150	200	290	340	430	510	630	710	980	1060	—	—
<b>800</b>	<b>900</b>	100	150	160	210	320	370	480	570	700	790	1100	1200	—	—
<b>900</b>	<b>1000</b>	120	170	180	230	360	410	540	630	780	870	1200	1300	—	—
<b>1000</b>	<b>1120</b>	130	190	200	260	400	460	600	700	—	—	—	—	—	—
<b>1120</b>	<b>1250</b>	150	210	220	280	450	510	670	770	—	—	—	—	—	—
<b>1250</b>	<b>1400</b>	170	240	250	320	500	570	750	870	—	—	—	—	—	—

Remarks Axial internal clearance  $A_a = \Delta_r \cot \alpha \approx \frac{1.5}{e} \Delta_r$   
 where  $\Delta_r$  : Radial internal clearance  
 $\alpha$  : Contact angle  
 $e$  : Constant (Listed in bearing tables)

**Table 9.17 Axial Internal Clearances in Combined Angular Contact Ball Bearings (Measured Clearance)**

Units :  $\mu\text{m}$

Nominal Bore Diameter, $d$ (mm)		Axial Internal Clearance											
		Contact Angle 30°						Contact Angle 40°					
		CN		C3		C4		CN		C3		C4	
over	incl	min	max	min	max	min	max	min	max	min	max	min	max
—	10	9	29	29	49	49	69	6	26	26	46	46	66
10	18	10	30	30	50	50	70	7	27	27	47	47	67
18	24	19	39	39	59	59	79	13	33	33	53	53	73
24	30	20	40	40	60	60	80	14	34	34	54	54	74
30	40	26	46	46	66	66	86	19	39	39	59	59	79
40	50	29	49	49	69	69	89	21	41	41	61	61	81
50	65	35	60	60	85	85	110	25	50	50	75	75	100
65	80	38	63	63	88	88	115	27	52	52	77	77	100
80	100	49	74	74	99	99	125	35	60	60	85	85	110
100	120	72	97	97	120	120	145	52	77	77	100	100	125
120	140	85	115	115	145	145	175	63	93	93	125	125	155
140	160	90	120	120	150	150	180	66	96	96	125	125	155
160	180	95	125	125	155	155	185	68	98	98	130	130	160
180	200	110	140	140	170	170	200	80	110	110	140	140	170

**Remarks** This table is applicable to bearings in Tolerance Classes Normal and 6. For internal axial clearances in bearings in tolerance classes better than 5 and contact angles of 15° and 25°, it is advisable to consult NSK.

**Table 9.18 Axial Internal Clearance in Four-Point Contact Ball Bearings (Measured Clearances)**

Units :  $\mu\text{m}$

Nominal Bore Dia. $d$ (mm)		Axial Internal Clearance							
		C2		CN		C3		C4	
over	incl	min	max	min	max	min	max	min	max
10	18	15	55	45	85	75	125	115	165
18	40	26	66	56	106	96	146	136	186
40	60	36	86	76	126	116	166	156	206
60	80	46	96	86	136	126	176	166	226
80	100	56	106	96	156	136	196	186	246
100	140	66	126	116	176	156	216	206	266
140	180	76	156	136	196	176	246	226	296
180	220	96	176	156	226	206	276	256	326
220	260	115	196	175	245	225	305	285	365
260	300	135	215	195	275	255	335	315	395
300	350	155	235	215	305	275	365	345	425
350	400	175	265	245	335	315	405	385	475
400	500	205	305	285	385	355	455	435	525

**9.2.2 Selection of Bearing Internal Clearances**

Among the bearing internal clearances listed in the tables, the CN Clearance is adequate for standard operating conditions. The clearance becomes progressively smaller from C2 to C1 and larger from C3 to C5.

Standard operating conditions are defined as those where the inner ring speed is less than approximately 50% of the limiting speed listed in the bearing tables, the load is less than normal ( $P \leq 0.1C_r$ ), and the bearing is tight-fitted on the shaft.

As a measure to reduce bearing noise for electric motors, the radial clearance range is narrower than the normal class and the values are somewhat smaller for deep groove ball bearings and cylindrical roller bearings for electric motors. (Refer to Table 9.13.1 and 9.13.2)

Internal clearance varies with the fit and temperature differences in operation. The changes in radial clearance in a roller bearing are shown in Fig. 9.2.

**(1) Decrease in Radial Clearance Caused by Fitting and Residual Clearance**

When the inner ring or the outer ring is tight-fitted on a shaft or in a housing, a decrease in the radial internal clearance is caused by the expansion or contraction of the bearing rings. The decrease varies according to the bearing type and size and design of the shaft and housing. The amount of this decrease is approximately 70 to 90% of the interference (refer to Section 15.2, Fits (1), Pages A130 to A133). The internal clearance after subtracting this decrease from the theoretical internal clearance  $\Delta_0$  is called the residual clearance,  $\Delta_f$ .

**(2) Decrease in Radial Internal Clearance Caused by Temperature Differences between Inner and Outer Rings and Effective Clearance**

The frictional heat generated during operation is conducted away through the shaft and housing. Since housings generally conduct heat better than shafts, the temperature of the inner ring and the rolling elements is usually higher than that of the outer ring by 5 to 10 °C. If the shaft is heated or the housing is cooled, the difference in temperature between the inner and outer rings is greater. The radial clearance decreases due to the thermal expansion caused by the temperature difference between the inner and outer rings. The amount of this decrease can be calculated using the following equations:

$$\delta_t \doteq \alpha \Delta_t D_e \dots \dots \dots (9.6)$$

where  $\delta_t$ : Decrease in radial clearance due to temperature difference between inner and outer rings (mm)

$\alpha$ : Coefficient of linear expansion of bearing steel  $\doteq 12.5 \times 10^{-6} (1/^\circ\text{C})$

$\Delta_t$ : Temperature difference between inner and outer rings ( $^\circ\text{C}$ )

$D_e$ : Outer ring raceway diameter (mm)

For ball bearings

$$D_e \doteq \frac{1}{5} (4D+d) \dots \dots \dots (9.7)$$

For roller bearings

$$D_e \doteq \frac{1}{4} (3D+d) \dots \dots \dots (9.8)$$

The clearance after subtracting this  $\delta_t$  from the residual clearance,  $\Delta_f$  is called the effective clearance,  $\Delta$ . Theoretically, the longest life of a bearing can be expected when the effective clearance is slightly negative. However, it is difficult to achieve such an ideal condition, and an excessive negative clearance will greatly shorten the bearing life. Therefore, a clearance of zero or a slightly positive amount, instead of a negative one, should be selected. When single-row angular contact ball bearings or tapered roller bearings are used facing each other, there should be a small effective clearance, unless a preload is required. When two cylindrical roller bearings with a rib on one side are used facing each other, it is necessary to provide adequate axial clearance to allow for shaft elongation during operation.

The radial clearances used in some specific applications are given in Table 9.19. Under special operating conditions, it is advisable to consult NSK.

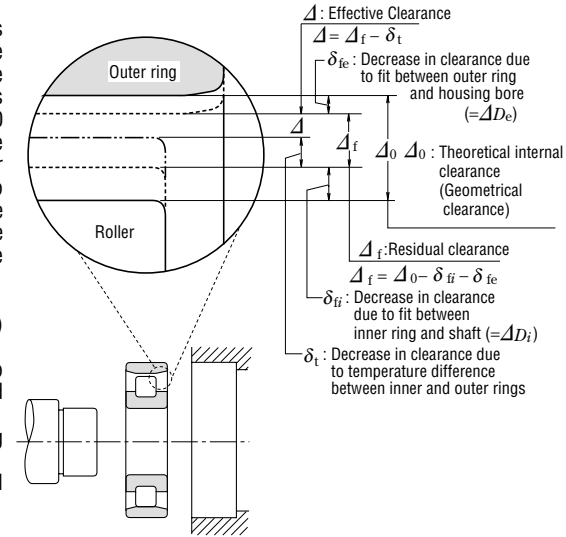

**Fig. 9.2 Changes in Radial Internal Clearance of Bearings**

**Table 9.19 Examples of Clearances for Specific Applications**

Operating Conditions	Examples	Internal Clearance
When shaft deflection is large.	Semi-floating rear wheels of automobiles	C5 or equivalent
When steam passes through hollow shafts or roller shafts are heated.	Dryers in paper making machines	C3, C4
	Table rollers for rolling mills	C3
When impact loads and vibration are severe or when both the inner and outer rings are tight-fitted.	Traction motors for railways	C4
	Vibrating screens	C3, C4
	Fluid couplings	C4
When both the inner and outer rings are loose-fitted.	Final reduction gears for tractors	C4
	Rolling mill roll necks	C2 or equivalent
When noise and vibration restrictions are severe	Small motors with special specifications	C1, C2, CM
When clearance is adjusted after mounting to prevent shaft deflection, etc.	Main shafts of lathes	CC9, CC1

## 10. PRELOAD

Rolling bearings usually retain some internal clearance while in operation. In some cases, however, it is desirable to provide a negative clearance to keep them internally stressed. This is called "preloading". A preload is usually applied to bearings in which the clearance can be adjusted during mounting, such as angular contact ball bearings or tapered roller bearings. Usually, two bearings are mounted face-to-face or back-to-back to form a duplex set with a preload.

### 10.1 Purpose of Preload

The main purposes and some typical applications of preloaded bearings are as follows:

- (1) To maintain the bearings in exact position both radially and axially and to maintain the running accuracy of the shaft.  
...Main shafts of machine tools, precision instruments, etc.
- (2) To increase bearing rigidity  
...Main shafts of machine tools, pinion shafts of final drive gears of automobiles, etc.
- (3) To minimize noise due to axial vibration and resonance  
...Small electric motors, etc.
- (4) To prevent sliding between the rolling elements and raceways due to gyroscopic moments  
...High speed or high acceleration applications of angular contact ball bearings, and thrust ball bearings
- (5) To maintain the rolling elements in their proper position with the bearing rings  
...Thrust ball bearings and spherical thrust roller bearings mounted on a horizontal shaft

### 10.2 Preloading Methods

#### 10.2.1 Position Preload

A position preload is achieved by fixing two axially opposed bearings in such a way that a preload is imposed on them. Their position, once fixed, remain unchanged while in operation. In practice, the following three methods are generally used to obtain a position preload.

- (1) By installing a duplex bearing set with previously adjusted stand-out dimensions (see Page A7, Fig. 1.1) and axial clearance.
- (2) By using a spacer or shim of proper size to obtain the required spacing and preload. (Refer to Fig. 10.1)
- (3) By utilizing bolts or nuts to allow adjustment of the axial preload. In this case, the starting torque should be measured to verify the proper preload.

#### 10.2.2 Constant-Pressure Preload

A constant pressure preload is achieved using a coil or leaf spring to impose a constant preload. Even if the relative position of the bearings changes during operation, the magnitude of the preload remains relatively constant (refer to Fig. 10.2)

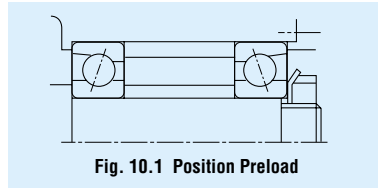

Fig. 10.1 Position Preload

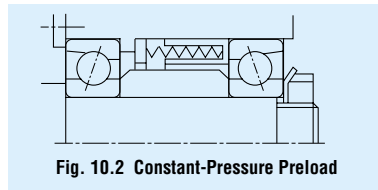

Fig. 10.2 Constant-Pressure Preload

### 10.3 Preload and Rigidity

#### 10.3.1 Position Preload and Rigidity

When the inner rings of the duplex bearings shown in Fig.10.3 are fixed axially, bearings A and B are displaced  $\delta_{a0}$  and axial space  $2\delta_{a0}$  between the inner rings is eliminated. With this condition, a preload  $F_{a0}$  is imposed on each bearing. A preload diagram showing bearing rigidity, that is the relation between load and displacement with a given axial load  $F_a$  imposed on a duplex set, is shown in Fig. 10.4.

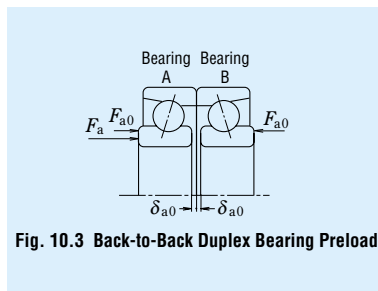

Fig. 10.3 Back-to-Back Duplex Bearing Preload

#### 10.3.2 Constant-Pressure Preload and Rigidity

A preload diagram for duplex bearings under a constant-pressure preload is shown in Fig. 10.5. The deflection curve of the spring is nearly parallel to the horizontal axis because the rigidity of springs is lower than that of the bearing. As a result, the rigidity under a constant-pressure preload is approximately equal to that for a single bearing with a preload  $F_{a0}$  applied to it. Fig. 10.6 presents a comparison of the rigidity of a bearing with a position preload and one with a constant-pressure preload.

### 10.4 Selection of Preloading Method and Amount of Preload

#### 10.4.1 Comparison of Preloading Methods

A comparison of the rigidity using both preloading methods is shown in Fig. 10.6. The position preload and constant-pressure preload may be compared as follows:

- (1) When both of the preloads are equal, the position preload provides greater bearing rigidity, in other words, the deflection due to external loads is less for bearings with a position preload.
- (2) In the case of a position preload, the preload varies depending on such factors as a difference in axial expansion due to a temperature difference between the shaft and housing, a difference in radial expansion due to a temperature difference between the inner and outer rings, deflection due to load, etc.

In the case of a constant-pressure preload, it is possible to minimize any change in the preload because the variation of the spring load with shaft expansion and contraction is negligible. From the foregoing explanation, it is seen that position preloads are generally preferred for increasing rigidity and constant-pressure preloads are more suitable for high speed applications, for prevention of axial vibration, for use with thrust bearings on horizontal shafts, etc.

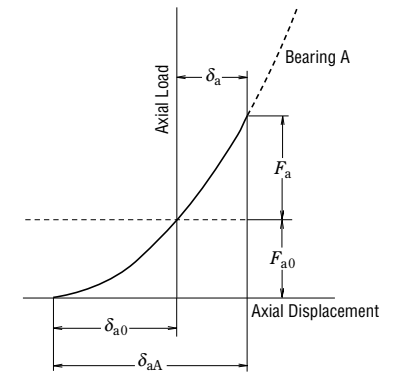
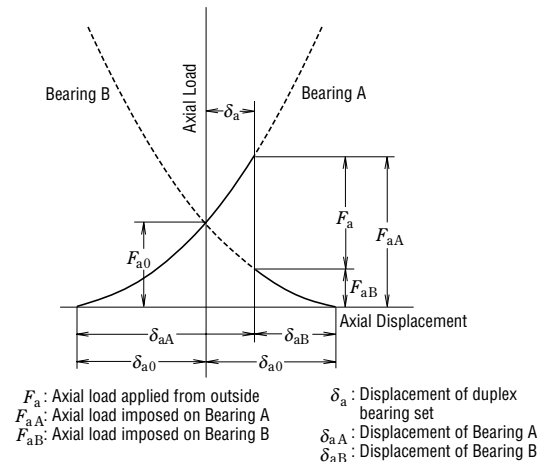

Fig. 10.5 Axial Displacement with Constant-Pressure Preload



$F_a$ : Axial load applied from outside  
 $F_{aA}$ : Axial load imposed on Bearing A  
 $F_{aB}$ : Axial load imposed on Bearing B  
 $\delta_a$ : Displacement of duplex bearing set  
 $\delta_{aA}$ : Displacement of Bearing A  
 $\delta_{aB}$ : Displacement of Bearing B

Fig. 10.4 Axial Displacement with Position Preload

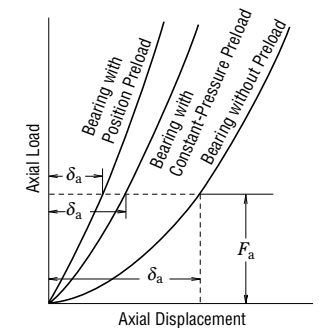

Fig. 10.6 Comparison of Rigidities and Preloading Methods

10.4.2 Amount of Preload

If the preload is larger than necessary, abnormal heat generation, increased frictional torque, reduced fatigue life, etc. may occur. The amount of the preload should be carefully determined considering the operating conditions and the purpose of the preload.

(1) Preloading of Duplex Angular Contact Ball Bearings

Average preloads for duplex angular contact ball bearings (contact angle of 15°) with precision better than P5 class, which are used on the main shafts of machine tools, are listed in Table 10.2.

The recommended fitting between the shaft and inner ring and between the housing and outer ring are listed in Table 10.1. In the case of fits with housings, the lower limit of the fitting range should be selected for fixed-end bearings and the upper limit for free-end bearings.

As a general rule, an extra light or light preload should be selected for grinding spindles and the main shafts of machining centers, while a medium preload should be adopted for the main shafts of lathes requiring rigidity.

When speeds result in a value of  $D_{pw} \times n$  ( $d_m n$  value) higher than 500000, the preload should be very carefully studied and selected. In such a case, please consult with NSK beforehand.

Table 10. 1 Recommended Fitting for High Accuracy Duplex Angular Contact Ball Bearings with Preload

Units : μm

Nominal Bore Dia. <i>d</i> (mm)		Target Shaft Interference	Nominal Outside Dia. <i>D</i> (mm)		Target Housing Clearance
over	incl		over	incl	
—	18	0 ~ 2	—	18	—
18	30	0 ~ 2.5	18	30	2~ 6
30	50	0 ~ 2.5	30	50	2~ 6
50	80	0 ~ 3	50	80	3~ 8
80	120	0 ~ 4	80	120	3~ 9
120	150	—	120	150	4~12
150	180	—	150	180	4~12
180	250	—	180	250	5~15

Table 10. 2 Preloads for Duplex

Table 10. 2. 2 Duplex

Units : N

Preloads

Bearing No.	Preloads			
	Extra light Preload EL	Light Preload L	Medium Preload M	Heavy Preload H
7900 C	7	15	29	59
7901 C	8.6	15	39	78
7902 C	12	25	49	100
7903 C	12	25	59	120
7904 C	19	39	78	150
7905 C	19	39	100	200
7906 C	24	49	100	200
7907 C	34	69	150	290
7908 C	39	78	200	390
7909 C	50	100	200	390
7910 C	50	100	250	490
7911 C	60	120	290	590
7912 C	60	120	290	590
7913 C	75	150	340	690
7914 C	100	200	490	980
7915 C	100	200	490	980
7916 C	100	200	490	980
7917 C	145	290	640	1 270
7918 C	145	290	740	1 470
7919 C	145	290	780	1 570
7920 C	195	390	880	1 770

Units : N

Preloads

Bearing No.	Preloads	
	Extra light Preload EL	Light Preload L
7000 C	12	25
7001 C	12	25
7002 C	14	29
7003 C	14	29
7004 C	24	49
7005 C	29	59
7006 C	39	78
7007 C	60	120
7008 C	60	120
7009 C	75	150
7010 C	75	150
7011 C	100	200
7012 C	100	200
7013 C	125	250
7014 C	145	290
7015 C	145	290
7016 C	195	390
7017 C	195	390
7018 C	245	490
7019 C	270	540
7020 C	270	540

(2) Preload of Thrust Ball Bearings

When the balls in thrust ball bearings rotate at relatively high speeds, sliding due to gyroscopic moments on the balls may occur. The larger of the two values obtained from Equations(10.1) and (10.2) below should be adopted as the minimum axial load in order to prevent such sliding

$$F_{a \min} = \frac{C_{0a}}{100} \left( \frac{n}{N_{\max}} \right)^2 \dots\dots\dots (10.1)$$

$$F_{a \min} = \frac{C_{0a}}{1000} \dots\dots\dots (10.2)$$

where  $F_{a \min}$  : Minimum axial load (N), {kgf}  
 $n$  : Speed (rpm)  
 $C_{0a}$  : Basic static load rating (N), {kgf}  
 $N_{\max}$  : Limiting speed (oil lubrication) (rpm)

(3) Preload of Spherical Thrust Roller Bearings

When spherical thrust roller bearings are used, damage such as scoring may occur due to sliding between the rollers and outer ring raceway. The minimum axial load  $F_{a \min}$  necessary to prevent such sliding is obtained from the following equation:

$$F_{a \min} = \frac{C_{0a}}{1000} \dots\dots\dots (10.3)$$

Angular Contact Ball Bearings

Bearings of Series 70

Units : N

Preloads

Bearing No.	Preloads	
	Medium Preload M	Heavy Preload H
49	100	
59	120	
69	150	
69	150	
120	250	
150	290	
200	390	
250	490	
290	590	
340	690	
390	780	
490	980	
540	1 080	
540	1 080	
740	1 470	
780	1 570	
930	1 860	
980	1 960	
1 180	2 350	
1 180	2 350	
1 270	2 550	

Table 10. 2. 3 Duplex Bearings of Series 72

Units : N

Preloads

Bearing No.	Preloads			
	Extra light Preload EL	Light Preload L	Medium Preload M	Heavy Preload H
7200 C	14	29	69	150
7201 C	19	39	100	200
7202 C	19	39	100	200
7203 C	24	49	150	290
7204 C	34	69	200	390
7205 C	39	78	200	390
7206 C	60	120	290	590
7207 C	75	150	390	780
7208 C	100	200	490	980
7209 C	125	250	540	1 080
7210 C	125	250	590	1 180
7211 C	145	290	780	1 570
7212 C	195	390	930	1 860
7213 C	220	440	1 080	2 160
7214 C	245	490	1 180	2 350
7215 C	270	540	1 230	2 450
7216 C	295	590	1 370	2 750
7217 C	345	690	1 670	3 330
7218 C	390	780	1 860	3 730
7219 C	440	880	2 060	4 120
7220 C	490	980	2 350	4 710

# 11. DESIGN OF SHAFTS AND HOUSINGS

## 11.1 Accuracy and Surface Finish of Shafts and Housings

If the accuracy of a shaft or housing does not meet the specification, the performance of the bearings will be affected and they will not provide their full capability. For example, inaccuracy in the squareness of the shaft shoulder may cause misalignment of the bearing inner and outer rings, which may reduce the bearing fatigue life by adding an edge load in addition to the normal load. Cage fracture and seizure sometimes occur for this same reason. Housings should be rigid in order to provide firm bearing support. High rigidity housings are advantageous also from the standpoint of noise, load distribution, etc.

For normal operating conditions, a turned finish or smooth bored finish is sufficient for the fitting surface; however, a ground finish is necessary for applications where vibration and noise must be low or where heavy loads are applied.

In cases where two or more bearings are mounted in one single-piece housing, the fitting surfaces of the housing bore should be designed so both bearing seats may be finished together with one operation such as in-line boring. In the case of split housings, care must be taken in the fabrication of the housing so the outer ring will not become deformed during installation. The accuracy and surface finish of shafts and housings are listed in Table 11.1 for normal operating conditions.

**Table 11.1 Accuracy and Roughness of Shaft and Housing**

Item	Class of Bearings	Shaft	Housing Bore
Tolerance for Out-of-roundness	Normal, Class 6	$\frac{IT3}{2} \sim \frac{IT4}{2}$	$\frac{IT4}{2} \sim \frac{IT5}{2}$
	Class 5, Class 4	$\frac{IT2}{2} \sim \frac{IT3}{2}$	$\frac{IT2}{2} \sim \frac{IT3}{2}$
Tolerance for Cylindricity	Normal, Class 6	$\frac{IT3}{2} \sim \frac{IT4}{2}$	$\frac{IT4}{2} \sim \frac{IT5}{2}$
	Class 5, Class 4	$\frac{IT2}{2} \sim \frac{IT3}{2}$	$\frac{IT2}{2} \sim \frac{IT3}{2}$
Tolerance for Shoulder Runout	Normal, Class 6	IT3	IT3~IT4
	Class 5, Class 4	IT3	IT3
Roughness of Fitting Surfaces $R_a$	Small Bearings	0.8	1.6
	Large Bearings	1.6	3.2

**Remarks** This table is for general recommendation using radius measuring method, the basic tolerance (IT) class should be selected in accordance with the bearing precision class. Regarding the figures of IT, please refer to the Appendix Table 11 (page C22).

In cases that the outer ring is mounted in the housing bore with interference or that a thin cross-section bearing is mounted on a shaft and housing, the accuracy of the shaft and housing should be higher since this affects the bearing raceway directly.

## 11.2 Shoulder and Fillet Dimensions

The shoulders of the shaft or housing in contact with the face of a bearing must be perpendicular to the shaft center line. (Refer to Table 11.1) The front face side shoulder bore of the housing for a tapered roller bearing should be parallel with the bearing axis in order to avoid interference with the cage.

The fillets of the shaft and housing should not come in contact with the bearing chamfer; therefore, the fillet radius  $r_a$  must be smaller than the minimum bearing chamfer dimension  $r$  or  $r_1$ .

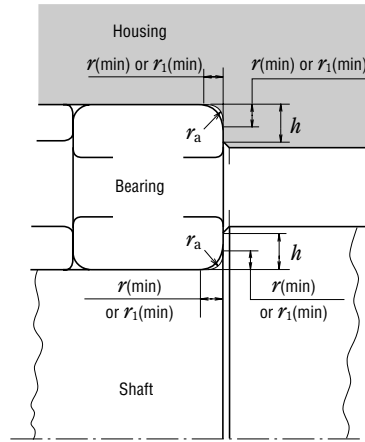

**Fig. 11.1 Chamfer Dimensions, Fillet Radius of Shaft and Housing, and Shoulder Height**

The shoulder heights for both shafts and housings for radial bearings should be sufficient to provide good support over the face of the bearings, but enough face should extend beyond the shoulder to permit use of special dismounting tools. The recommended minimum shoulder heights for metric series radial bearings are listed in Table 11.2

Nominal dimensions associated with bearing mounting are listed in the bearing tables including the proper shoulder diameters. Sufficient shoulder height is particularly important for supporting the side ribs of tapered roller bearings and cylindrical roller bearings subjected to high axial loads.

The values of  $h$  and  $r_a$  in Table 11.2 should be adopted in those cases where the fillet radius of the shaft or housing is as shown in Fig. 11.2 (a), while the values in Table 11.3 are generally used with an undercut fillet radius produced when grinding the shaft as shown in Fig. 11.2 (b).

**Table 11.2 Recommended Minimum Shoulder Heights for Use with Metric Series Radial Bearings**

Units : mm

Nominal Chamfer Dimensions	Shaft or Housing		
	Fillet Radius	Minimum Shoulder Heights $h$ (min)	
		Deep Groove Ball Bearings, Self-Aligning Ball Bearings, Cylindrical Roller Bearings, Needle Roller Bearings	Angular Contact Ball Bearings, Tapered Roller Bearings, Spherical Roller Bearings
$r$ (min) or $r_1$ (min)	$r_a$ (max)		
0.05	0.05	0.2	—
0.08	0.08	0.3	—
0.1	0.1	0.4	—
0.15	0.15	0.6	—
0.2	0.2	0.8	—
0.3	0.3	1	1.25
0.6	0.6	2	2.5
1	1	2.5	3
1.1	1	3.25	3.5
1.5	1.5	4	4.5
2	2	4.5	5
2.1	2	5.5	6
2.5	2	—	6
3	2.5	6.5	7
4	3	8	9
5	4	10	11
6	5	13	14
7.5	6	16	18
9.5	8	20	22
12	10	24	27
15	12	29	32
19	15	38	42

- Remarks**
1. When heavy axial loads are applied, the shoulder height must be sufficiently higher than the values listed.
  2. The fillet radius of the corner is also applicable to thrust bearings.
  3. The shoulder diameter is listed instead of shoulder height in the bearing tables.

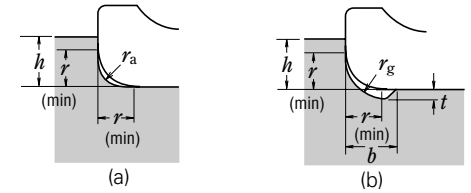

**Fig. 11.2 Chamfer Dimensions, Fillet Radius, and Shoulder Height**

**Table 11.3 Shaft Undercut**

Units : mm

Chamfer Dimensions of Inner and Outer Rings $r$ (min) or $r_1$ (min)	Undercut Dimensions		
	$t$	$r_g$	$b$
1	0.2	1.3	2
1.1	0.3	1.5	2.4
1.5	0.4	2	3.2
2	0.5	2.5	4
2.1	0.5	2.5	4
2.5	0.5	2.5	4
3	0.5	3	4.7
4	0.5	4	5.9
5	0.6	5	7.4
6	0.6	6	8.6
7.5	0.6	7	10



For thrust bearings, the squareness and contact area of the supporting face for the bearing rings must be adequate. In the case of thrust ball bearings, the housing shoulder diameter  $D_a$  should be less than the pitch circle diameter of the balls, and the shaft shoulder diameter  $d_a$  should be greater than the pitch circle diameter of the balls (Fig. 11.3).

For thrust roller bearings, it is advisable for the full contact length between rollers and rings to be supported by the shaft and housing shoulder (Fig. 11.4).

These diameters  $d_a$  and  $D_a$  are listed in the bearing tables.

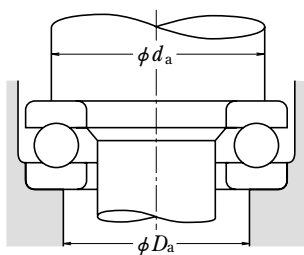

Fig. 11.3 Face Supporting Diameters for Thrust Ball Bearings

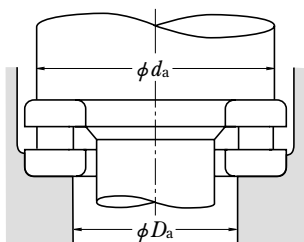

Fig. 11.4 Face Supporting Diameters for Thrust Roller Bearings

### 11.3 Bearing Seals

To insure the longest possible life of a bearing, it may be necessary to provide seals to prevent leakage of lubricant and entry of dust, water and other harmful material like metallic particles. The seals must be free from excessive running friction and the probability of seizure. They should also be easy to assemble and disassemble. It is necessary to select a suitable seal for each application considering the lubricating method.

#### 11.3.1 Non-Contact Type Seals

Various sealing devices that do not contact the shaft, such as oil grooves, flingers, and labyrinths, are available. Satisfactory sealing can usually be obtained with such seals because of their close running clearance. Centrifugal force may also assist in preventing internal contamination and leakage of the lubricant.

#### (1) Oil Groove Seals

The effectiveness of oil groove seals is obtained by means of the small gap between the shaft and housing bore and by multiple grooves on either or both of the housing bore and shaft surface (Fig. 11.5 (a), (b)). Since the use of oil grooves alone is not completely effective, except at low speeds, a flinger or labyrinth type seal is often combined with an oil groove seal (Fig. 11.5 (c)). The entry of dust is impeded by packing grease with a consistency of about 200 into the grooves.

The smaller the gap between the shaft and housing, the greater the sealing effect; however, the shaft and housing must not come in contact while running. The recommended gaps are given in Table 11.4.

The recommended groove width is approximately 3 to 5mm, with a depth of about 4 to 5mm. In the case of sealing methods using grooves only, there should be three or more grooves.

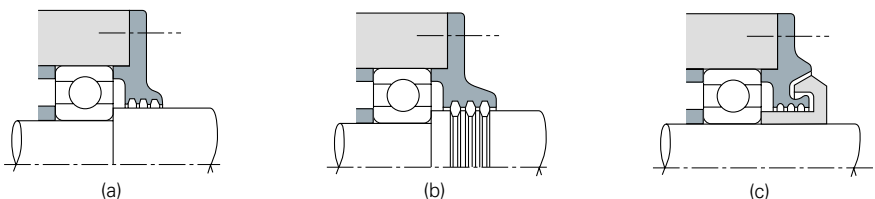

Fig. 11.5 Examples of Oil Grooves

#### (2) Flinger (Slinger) Type Seals

A flinger is designed to force water and dust away by means of the centrifugal force acting on any contaminants on the shaft. Sealing mechanisms with flingers inside the housing as shown in Fig. 11.6 (a), (b) are mainly intended to prevent oil leakage, and are used in environments with relatively little dust. Dust and moisture are prevented from entering by the centrifugal force of flingers shown in Figs 11.6 (c), (d).

Table 11.4 Gaps between Shafts and Housings for Oil-Groove Type Seals

Nominal Shaft Diameter	Units : mm	
	Radial Gap	
Under 50	0.25 ~ 0.4	
50-200	0.5 ~ 1.5	

Table 11.5 Labyrinth Seal Gaps

Nominal Shaft Diameter	Units : mm	
	Labyrinth Gaps	
	Radial Gap	Axial Gap
Under 50	0.25 ~ 0.4	1 ~ 2
50-200	0.5 ~ 1.5	2 ~ 5

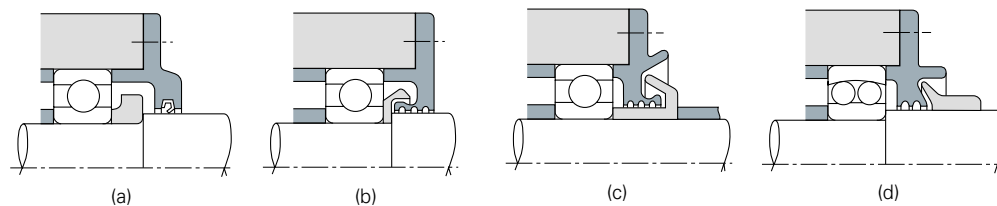

Fig. 11.6 Examples of Flinger Configurations

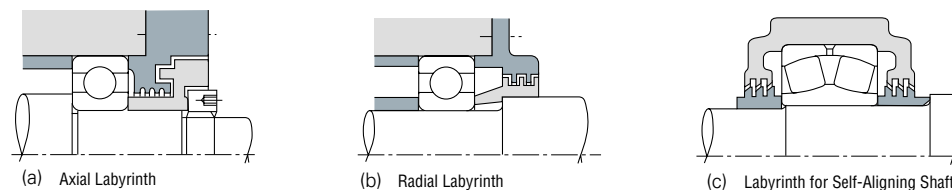

Fig. 11.7 Examples of Labyrinth Designs



## 12. LUBRICATION

### 11.3.2 Contact Type Seals

The effectiveness of contact seals is achieved by the physical contact between the shaft and seal, which may be made of synthetic rubber, synthetic resin, felt, etc. Oil seals with synthetic rubber lips are most frequently used.

#### (1) Oil Seals

Many types of oil seals are used to prevent lubricant from leaking out as well as to prevent dust, water, and other foreign matter from entering (Figs. 11.8 and 11.9)

In Japan, such oil seals are standardized (Refer to JIS B 2402) on the basis of type and size. Since many oil seals are equipped with circumferential springs to maintain adequate contact force, oil seals can follow the non-uniform rotational movement of a shaft to some degree.

Seal lip materials are usually synthetic rubber including nitrile, acrylate, silicone, and fluorine. Tetrafluoride ethylene is also used. The maximum allowable operating temperature for each material increases in this same order.

Synthetic rubber oil seals may cause trouble such as overheating, wear, and seizure, unless there is an oil film between the seal lip and shaft. Therefore, some lubricant should be applied to the seal lip when the seals are installed. It is also desirable for the lubricant inside the housing to spread a little between the sliding surfaces.

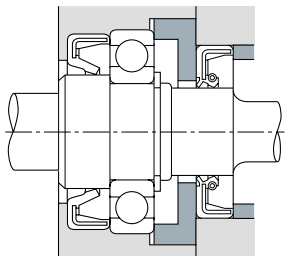

Fig. 11.8 Example of Application of Oil Seal (1)

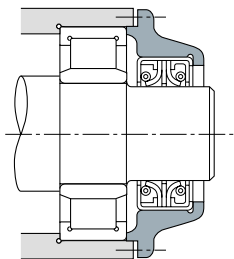

Fig. 11.9 Example of Application of Oil Seal (2)

The permissible circumferential speed for oil seals varies depending on the type, the finish of the shaft surface, liquid to be sealed, temperature, shaft eccentricity, etc. The temperature range for oil seals is restricted by the lip material. Approximate circumferential surface speeds and temperature permitted under favorable conditions are listed in Table 11.6.

When oil seals are used at high circumferential surface speed or under high internal pressure, the contact surface of the shaft must be smoothly finished and the shaft eccentricity should be less than 0.02 to 0.05mm. The hardness of the shaft's contact surface should be made higher than HRC40 by means of heat treatment or hard chrome plating in order to gain abrasion resistance. If possible, a hardness of more than HRC 55 is recommended.

The approximate level of contact surface finish required for several shaft circumferential surface speeds is given in Table 11.7.

#### (2) Felt Seals

Felt seals are one of the simplest and most common seals being used for transmission shafts, etc.

However, since oil permeation and leakage are unavoidable if oil is used, this type of seal is used only for grease lubrication, primarily to prevent dust and other foreign matter from entering. Felt seals are not suitable for circumferential surface speeds exceeding 4m/sec; therefore, it is preferable to replace them with synthetic rubber seals depending on the application.

Table 11.6 Permissible Circumferential Surface Speeds and Temperature Range for Oil Seals

Seal Materials		Permissible Circumferential Speeds(m/sec)	Operating Temperature Range(°C) (¹)
Synthetic Rubber	Nitrile Rubber	Under 16	-25 to +100
	Acrylic Rubber	Under 25	-15 to +130
	Silicone Rubber	Under 32	-70 to +200
	Fluorine-containes Rubber	Under 32	-30 to +200
Tetrafluoride Ethylene Resin		Under 15	-50 to +220

Note (¹) The upper limit of the temperature range may be raised about 20 °C for operation for short intervals.

Table 11.7 Shaft Circumferential Surface Speeds and Finish of Contact Surfaces

Circumferential Surface Speeds(m/s)	Surface Finish R <sub>a</sub>
Under 5	0.8
5 to 10	0.4
Over 10	0.2

### 12.1 Purposes of Lubrication

The main purposes of lubrication are to reduce friction and wear inside the bearings that may cause premature failure. The effects of lubrication may be briefly explained as follows:

#### (1) Reduction of Friction and Wear

Direct metallic contact between the bearing rings, rolling elements and cage, which are the basic components of a bearing, is prevented by an oil film which reduces the friction and wear in the contact areas.

#### (2) Extension of Fatigue Life

The rolling fatigue life of bearings depends greatly upon the viscosity and film thickness between the rolling contact surfaces. A heavy film thickness prolongs the fatigue life, but it is shortened if the viscosity of the oil is too low so the film thickness is insufficient.

#### (3) Dissipation of Frictional Heat and Cooling

Circulation lubrication may be used to carry away frictional heat or heat transferred from the outside to prevent the bearing from overheating and the oil from deteriorating.

#### (4) Others

Adequate lubrication also helps to prevent foreign material from entering the bearings and guards against corrosion or rusting.

### 12.2 Lubricating Methods

The various lubricating methods are first divided into either grease or oil lubrication. Satisfactory bearing performance can be achieved by adopting the lubricating method which is most suitable for the particular application and operating condition.

In general, oil offers superior lubrication; however, grease lubrication allows a simpler structure around the bearings. A comparison of grease and oil lubrication is given in Table 12.1.

Table 12.1 Comparison of Grease and Oil Lubrication

Item	Grease Lubrication	Oil Lubrication
Housing Structure and Sealing Method	Simple	May be complex, Careful maintenance required.
Speed	Limiting speed is 65% to 80% of that with oil lubrication.	Higher limiting speed.
Cooling Effect	Poor	Heat transfer is possible using forced oil circulation.
Fluidity	Poor	Good
Full Lubricant Replacement	Sometimes difficult	Easy
Removal of Foreign Matter	Removal of particles from grese is impossible.	Easy
External Contamination due to Leakage	Surroundings seldom contaminated by leakage.	Often leaks without proper countermeasures. Not suitable if external contamination must be avoided.

#### 12.2.1 Grease Lubrication

##### (1) Grease Quantity

The quantity of grease to be packed in a housing depends on the housing design and free space, grease characteristics, and ambient temperature. For example, the bearings for the main shafts of machine tools, where the accuracy may be impaired by a small temperature rise, require only a small amount of grease. The quantity of grease for ordinary bearings is determined as follows.

Sufficient grease must be packed inside the bearing including the cage guide face. The available space inside the housing to be packed with grease depends on the speed as follows:

1/2 to 2/3 of the space ... When the speed is less than 50% of the limiting speed.

1/3 to 1/2 of the space ... When the speed is more than 50% of the limiting speed.

**(2) Replacement of Grease**

Grease, once packed, usually need not be replenished for a long time; however, for severe operating conditions, grease should be frequently replenished or replaced. In such cases, the bearing housing should be designed to facilitate grease replenishment and replacement. When replenishment intervals are short, provide replenishment and discharge ports at appropriate positions so deteriorated grease is replaced by fresh grease. For example, the housing space on the grease supply side can be divided into several sections with partitions. The grease on the partitioned side gradually passes through the bearings and old grease forced from the bearing is discharged through a grease valve (Fig. 12.1). If a grease valve is not used, the space on

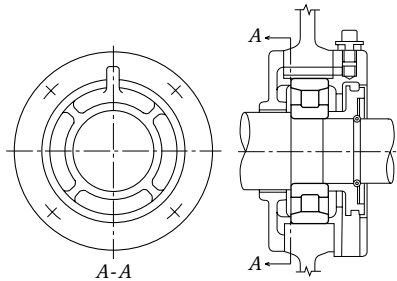

**Fig. 12.1** Combination of Partitioned Grease Reservoir and Grease Valve

the discharge side is made larger than the partitioned side so it can retain the old grease, which is removed periodically by removing the cover.

**(3) Replenishing Interval**

Even if high-quality grease is used, there is deterioration of its properties with time; therefore, periodic replenishment is required. Figs 12.2 (1) and (2) show the replenishment time intervals for various bearing types running at different speeds. Figs.12.2 (1) and (2) apply for the condition of high-quality lithium soap-mineral oil grease, bearing temperature of 70°C, and normal load ( $P/C=0.1$ ).

· Temperature  
If the bearing temperature exceeds 70°C, the replenishment time interval must be reduced by half for every 15°C temperature rise of the bearings.

· Grease  
In case of ball bearings especially, the replenishing time interval can be extended depending on used grease type. (For example, high-quality lithium soap-synthetic oil grease may extend about two times of replenishing time interval shown in Fig.12.2 (1). If the temperature of the bearings is less than 70°C, the usage of lithium soap-mineral oil grease or lithium soap-synthetic oil grease is appropriate.)

· Load  
The replenishing time interval depends on the magnitude of the bearing load. Please refer to Fig.12.2 (3).  
If  $P/C$  exceeds 0.16, it is advisable to consult NSK.

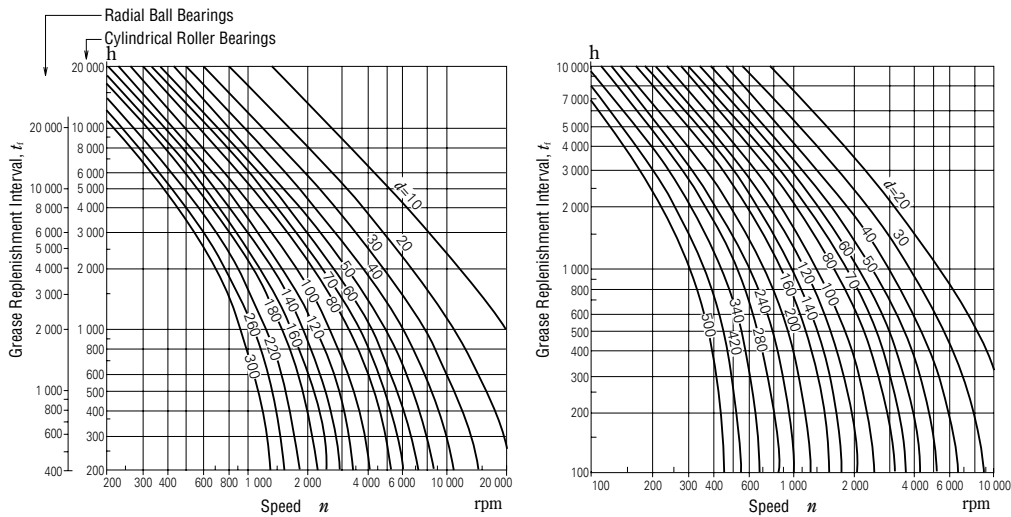

(1) Radial Ball Bearings, Cylindrical Roller Bearings

(2) Tapered Roller Bearings, Spherical Roller Bearings

(3) Load factor

$P/C$	$\leq 0.06$	0.1	0.13	0.16
Load factor	1.5	1	0.65	0.45

**Fig. 12.2** Grease Replenishment Intervals

**(4) Grease Life of Totally Enclosed Ball Bearings**

When grease is packed into single-row deep groove ball bearings, the grease life may be estimated using Equation (12.1) or (12.2) or Fig. 12.3: (General purpose grease (1))

$$\log t = 6.54 - 2.6 \frac{n}{N_{max}} - \left(0.025 - 0.012 \frac{n}{N_{max}}\right) T \quad \text{.....(12.1)}$$

(Wide-range grease (2))

$$\log t = 6.12 - 1.4 \frac{n}{N_{max}} - \left(0.018 - 0.006 \frac{n}{N_{max}}\right) T \quad \text{.....(12.2)}$$

where  $t$ : Average grease life, (h)  
 $n$ : Speed (rpm)  
 $N_{max}$ : Limiting speed with grease lubrication (rpm) (values for ZZ and VV types listed in the bearing tables)  
 $T$ : Operating temperature °C

Equations (12.1) and (12.2) and Fig. 12.3 apply under the following conditions:

- (a) Speed,  $n$   
 $0.25 \leq \frac{n}{N_{max}} \leq 1$   
when  $\frac{n}{N_{max}} < 0.25$ , assume  $\frac{n}{N_{max}} = 0.25$

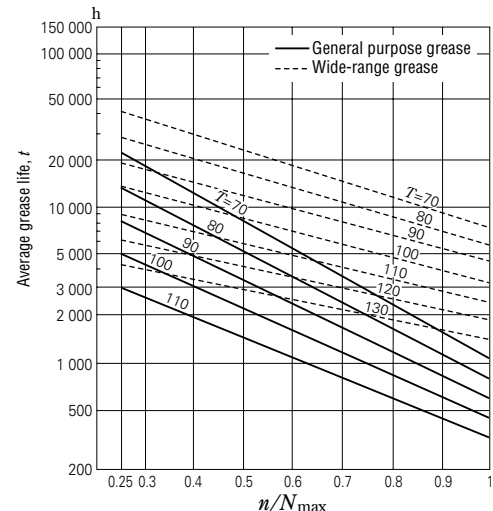

**Fig. 12.3** Grease Life of Sealed Ball Bearings

(b) Operating Temperature,  $T$   
For general purpose grease (1)

$$70^\circ\text{C} \leq T \leq 110^\circ\text{C}$$

For wide-range grease (2)

$$70^\circ\text{C} \leq T \leq 130^\circ\text{C}$$

When  $T < 70^\circ\text{C}$  assume  $T = 70^\circ\text{C}$

(c) Bearing Loads

The bearing loads should be about 1/10 or less of the basic load rating  $C_r$ .

**Notes** (1) Mineral-oil base greases (e.g. lithium soap base grease) which are often used over a temperature range of around - 10 to 110 °C.  
(2) Synthetic-oil base greases are usable over a wide temperature range of around - 40 to 130 °C.

**12.2.2 Oil Lubrication**

**(1) Oil Bath Lubrication**

Oil bath lubrication is a widely used with low or medium speeds. The oil level should be at the center of the lowest rolling element. It is desirable to provide a sight gauge so the proper oil level may be maintained (Fig. 12.4)

**(2) Drip-Feed Lubrication**

Drip feed lubrication is widely used for small ball bearings operated at relatively high speeds. As shown in Fig. 12.5, oil is stored in a visible oiler. The oil drip rate is controlled with the screw in the top.

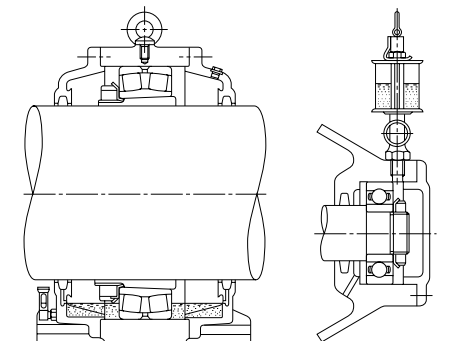

**Fig. 12.4** Oil Bath Lubrication

**Fig. 12.5** Drip Feed Lubrication

**(3) Splash Lubrication**

With this lubricating method, oil is splashed onto the bearings by gears or a simple rotating disc installed near bearings without submerging the bearings in oil. It is commonly used in automobile transmissions and final drive gears. Fig. 12.6 shows this lubricating method used on a reduction gear.

**(4) Circulating Lubrication**

Circulating lubrication is commonly used for high speed operation requiring bearing cooling and for bearings used at high temperatures. As shown in Fig. 12.7 (a), oil is supplied by the pipe on the right side, it travels through the bearing, and drains out through the pipe on the left. After being cooled in a reservoir, it returns to the bearing through a pump and filter.

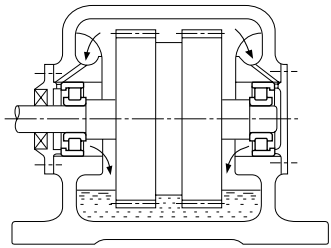

Fig. 12.6 Splash Lubrication

**(5) Jet Lubrication**

Jet lubrication is often used for ultra high speed bearings, such as the bearings in jet engines with a  $d_m n$  valve ( $d_m$ : pitch diameter of rolling element set in mm;  $n$ : rotational speed in rpm) exceeding one million. Lubricating oil is sprayed under pressure from one or more nozzles directly into the bearing.

Fig. 12.8 shows an example of ordinary jet lubrication. The lubricating oil is sprayed on the inner ring and cage guide face. In the case of high speed operation, the air surrounding the bearing rotates with it causing the oil jet to be deflected. The jetting speed of the oil from the nozzle should be more than 20% of the circumferential speed of the inner ring outer surface (which is also the guide face for the cage).

More uniform cooling and a better temperature distribution is achieved using more nozzles for a given amount of oil. It is desirable for the oil to be forcibly discharged so the agitating resistance of the lubricant can be reduced and the oil can effectively carry away the heat.

**(6) Oil Mist Lubrication**

Oil mist lubrication, also called oil fog lubrication, utilizes an oil mist sprayed into a bearing. This method has the following advantages:

- (a) Because of the small quantity of oil required, the oil agitation resistance is small, and higher speeds are possible.
- (b) Contamination of the vicinity around the bearing is slight because the oil leakage is small.
- (c) It is relatively easy to continuously supply fresh oil; therefore, the bearing life is extended.

This lubricating method is used in bearings for the high speed spindles of machine tools, high speed pumps, roll necks of rolling mills, etc (Fig. 12.9). For oil mist lubrication of large bearings, it is advisable to consult NSK.

**(7) Oil/Air Lubricating Method**

Using the oil/air lubricating method, a very small amount of oil is discharged intermittently by a constant-quantity piston into a pipe carrying a constant flow of compressed air. The oil flows along the wall of the pipe and approaches a constant flow rate.

- The major advantages of oil/air lubrication are:
- (a) Since the minimum necessary amount of oil is supplied, this method is suitable for high speeds because less heat is generated.
  - (b) Since the minimum amount of oil is fed continuously, bearing temperature remains stable. Also, because of the small amount of oil, there is almost no atmospheric pollution.
  - (c) Since only fresh oil is fed to the bearings, oil deterioration need not be considered.
  - (d) Since compressed air is always fed to the bearings, the internal pressure is high, so dust, cutting fluid, etc. cannot enter.
- For these reasons, this method is used in the main spindles of machine tools and other high speed applications (Fig. 12.10).

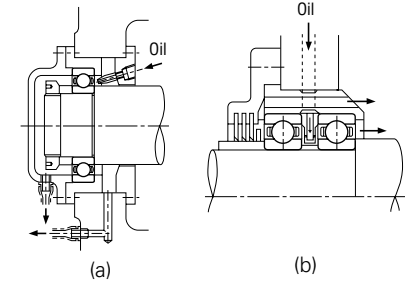

Fig. 12.8 Jet Lubrication

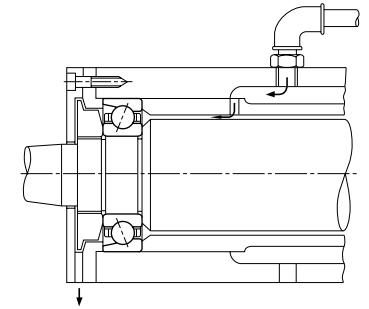

Fig. 12.9 Oil Mist Lubrication

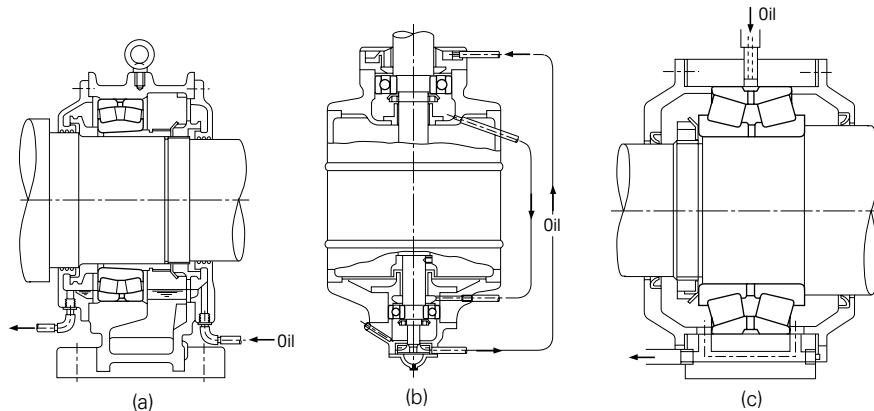

Fig. 12.7 Circulating Lubrication

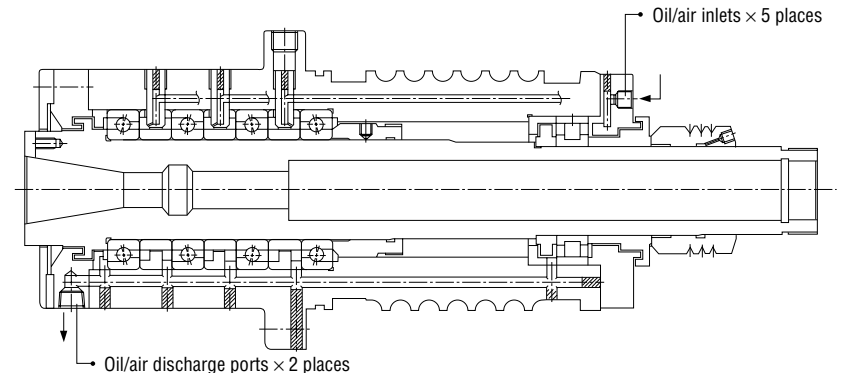

Fig. 12.10 Oil/Air Lubrication

12.3 Lubricants

12.3.1 Lubricating Grease

Grease is a semi-solid lubricant consisting of a base oil and a thickener. The main types and general properties of grease are shown in Table 12.2. It should be remembered that different brands of the same type of grease may have different properties.

(1) Base Oil

Mineral oils or synthetic oils such as silicone or diester oil are mainly used as the base oil for grease. The lubricating properties of grease depend mainly on the characteristics of its base oil. Therefore, the viscosity of the base oil is just as important when selecting grease as when selecting an oil. Usually, grease made with low viscosity base oils is more suitable for high speeds and low temperatures, while greases made with high viscosity base oils are more suited for high temperatures and heavy loads.

However, the thickener also influences the lubricating properties of grease; therefore, the selection criteria for grease is not the same as for lubricating oil.

(2) Thickener

As thickeners for lubricating grease, there are several types of metallic soaps, inorganic thickeners such as silica gel and bentonite, and heat resisting organic thickeners such as polyurea and fluorine compounds.

The type of thickener is closely related to the grease dropping point (1); generally, grease with a high dropping point also has a high temperature capability during operation. However, this type of grease does not have a high working temperature unless the base oil is heat-resistant. The highest possible working temperature for grease should be determined considering the heat resistance of the base oil.

The water resistance of grease depends upon the type of thickener. Sodium soap grease or compound grease containing sodium soap emulsifies when exposed to water or high humidity, and therefore, cannot be used where moisture is prevalent.

(3) Additives

Grease often contains various additives such as antioxidants, corrosion inhibitors, and extreme pressure additives to give it special properties. It is recommended that extreme pressure additives be used in heavy load applications. For long use without replenishment, an antioxidant should be added.

**Note** (1) The grease dropping point is that temperature at which a grease heated in a specified small container becomes sufficiently fluid to drip.

Table 12.2

Name (Popular name)	Lithium Grease		
	Li Soap		
Thickener			
Base Oil	Mineral Oil	Diester Oil, Polyatomic Ester Oil	Silicone Oil
Properties			
Dropping Point, °C	170~195	170~195	200~210
Working Temperatures, °C	-20~+110	-50~+130	-50~+160
Working Speed, % <sup>(1)</sup>	70	100	60
Mechanical Stability	Good	Good	Good
Pressure Resistance	Fair	Fair	Poor
Water Resistance	Good	Good	Good
Rust Prevention	Good	Good	Poor
Remarks	General purpose grease used for numerous applications	Good low temperature and torque characteristics. Often used for small motors and instrument bearings. Pay attention to rust caused by insulation varnish.	Mainly for high temperature applications. Unsuitable for bearings for high and low speeds or heavy loads or those having numerous sliding-contact areas (roller bearings, etc.)

**Note** (1) The values listed are percentages of the limiting speeds given in the bearing tables.

(4) Consistency

Consistency indicates the “softness” of grease. Table 12.3 shows the relation between consistency and working conditions.

(5) Mixing Different Types of Grease

In general, different brands of grease must not be mixed. Mixing grease with different types of thickeners may destroy its composition and physical properties. Even if the thickeners are of the same type, possible differences in the additive may cause detrimental effects.

Grease Properties

Sodium Grease (Fiber Grease)	Calcium Grease (Cup Grease)	Mixed Base Grease	Complex Base Grease (Complex Grease)	Non-Soap Base Grease (Non-Soap Grease)	
Na Soap	Ca Soap	Na + Ca Soap, Li + Ca Soap, etc.	Ca Complex Soap, Al Complex Soap, Li Complex Soap, etc.	Urea, Bentonite, Carbon Black, Fluoric Compounds, Heat Resistant Organic Compound, etc.	
Mineral Oil	Mineral Oil	Mineral Oil	Mineral Oil	Mineral Oil	Synthetic Oil (Ester Oil, Polyatomic Ester Oil, Synthetic Hydrocarbon Oil, Silicone Oil, Fluoric Based Oil)
170~210	70~90	160~190	180~300	230~	230~
-20~+130	-20~+60	-20~+80	-20~+130	-10~+130	~+220
70	40	70	70	70	40~100
Good	Poor	Good	Good	Good	Good
Fair	Poor	Fair to Good	Fair to Good	Fair	Fair
Poor	Good	Poor for Na Soap Grease	Good	Good	Good
Poor to Good	Good	Fair to Good	Fair to Good	Fair to Good	Fair to Good
Long and short fiber types are available. Long fiber grease is unsuitable for high speeds. Attention to water and high temperature is required.	Extreme pressure grease containing high viscosity mineral oil and extreme pressure additive (Pb soap, etc.) has high pressure resistance.	Often used for roller bearings and large ball bearing.	Suitable for extreme pressures mechanically stable	Mineral oil base grease is middle and high temperature purpose lubricant. Synthetic oil base grease is recommended for low or high temperature. Some silicone and fluorine oil based grease have poor rust prevention and noise.	

**Remarks** The grease properties shown here can vary between brands.

Table 12.3 Consistency and Working Conditions

Consistency Number	0	1	2	3	4
Consistency <sup>(1)</sup> 1/10 mm	355~385	310~340	265~295	220~250	175~205
Working Conditions (Application)	·For centralized oiling ·When fretting is likely to occur	·For centralized oiling ·When fretting is likely to occur ·For low temperatures	·For general use ·For sealed ball bearings	·For general use ·For sealed ball bearings ·For high temperatures	·For high temperatures ·For grease seals

**Note** (1) Consistency: The depth to which a cone descends into grease when a specified weight is applied, indicated in units of 1/10mm. The larger the value, the softer the grease.

**12.3.2 Lubricating Oil**

The lubricating oils used for rolling bearings are usually highly refined mineral oil or synthetic oil that have a high oil film strength and superior oxidation and corrosion resistance. When selecting a lubricating oil, the viscosity at the operating conditions is important. If the viscosity is too low, a proper oil film is not formed and abnormal wear and seizure may occur. On the other hand, if the viscosity is too high, excessive viscous resistance may cause heating or large power loss. In general, low viscosity oils should be used at high speed; however, the viscosity should increase with increasing bearing load and size. Table 12.4 gives generally recommended viscosities for bearings under normal operating conditions.

For use when selecting the proper lubricating oil, Fig. 12.11 shows the relationship between oil temperature and viscosity, and examples of selection are shown in Table 12.5.

**Table 12.4 Bearing Types and Proper Viscosity of Lubricating Oils**

Bearing Type	Proper Viscosity at Operating Temperature
Ball Bearings and Cylindrical Roller Bearings	Higher than 13mm <sup>2</sup> /s
Tapered Roller Bearings and Spherical Roller Bearings	Higher than 20mm <sup>2</sup> /s
Spherical Thrust Roller Bearings	Higher than 32mm <sup>2</sup> /s

**Remarks** 1mm<sup>2</sup>/s=1cSt (centistokes)

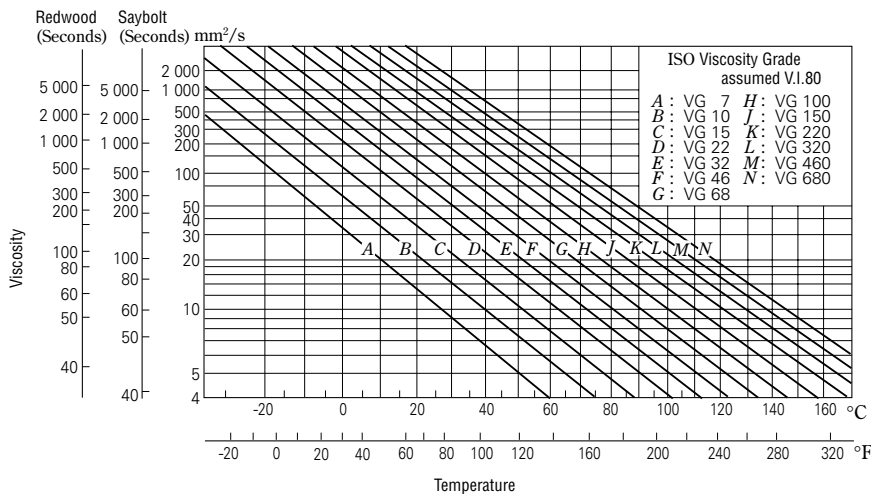

**Fig. 12.11 Temperature-Viscosity Chart**

**Oil Replacement Intervals**

Oil replacement intervals depend on the operating conditions and oil quantity. In those cases where the operating temperature is less than 50°C, and the environmental conditions are good with little dust, the oil should be replaced approximately once a year. However, in cases where the oil temperature is about 100°C, the oil must be changed at least once every three months.

If moisture may enter or if foreign matter may be mixed in the oil, then the oil replacement interval must be shortened. Mixing different brands of oil must be prevented for the same reason given previously for grease.

**Table 12.5 Examples of Selection Lubricating Oils**

Operating Temperature	Speed	Light or normal Load	Heavy or Shock Load
-30 to 0°C	Less than limiting speed	ISO VG 15, 22, 32 (refrigerating machine oil)	—
0~50°C	Less than 50% of limiting speed	ISO VG 32, 46, 68 (bearing oil, turbine oil)	ISO VG 46, 68, 100 (bearing oil, turbine oil)
	50 to 100% of limiting speed	ISO VG 15, 22, 32 (bearing oil, turbine oil)	ISO VG 22, 32, 46 (bearing oil, turbine oil)
	More than limiting speed	ISO VG 10, 15, 22 (bearing oil)	—
50~80°C	Less than 50% of limiting speed	ISO VG 100, 150, 220 (bearings oil)	ISO VG 150, 220, 320 (bearing oil)
	50 to 100% of limiting speed	ISO VG 46, 68, 100 (bearing oil, turbine oil)	ISO VG 68, 100, 150 (bearing oil, turbine oil)
	More than limiting speed	ISO VG 32, 46, 68 (bearing oil, turbine oil)	—
80~110°C	Less than 50% of limiting speed	ISO VG 320, 460 (bearing oil)	ISO VG 460, 680 (bearing oil, gear oil)
	50 to 100% of limiting speed	ISO VG 150, 220 (bearing oil)	ISO VG 220, 320 (bearing oil)
	More than limiting speed	ISO VG 68, 100 (bearing oil, turbine oil)	—

- Remarks**
- For the limiting speed, use the values listed in the bearing tables.
  - Refer to Refrigerating Machine Oils (JIS K 2211), Bearing Oils (JIS K 2239), Turbine Oils (JIS K 2213), Gear Oils (JIS K 2219).
  - If the operating temperature is near the high end of the temperature range listed in the left column, select a high viscosity oil.
  - If the operating temperature is lower than -30°C or higher than 110°C, it is advisable to consult NSK.



### 13. BEARING MATERIALS

The bearing rings and rolling elements of rolling bearings are subjected to repetitive high pressure with a small amount of sliding. The cages are subjected to tension and compression and sliding contact with the rolling elements and either or both of the bearing rings.

Therefore, the materials used for the rings, rolling elements, and cages require the following characteristics:

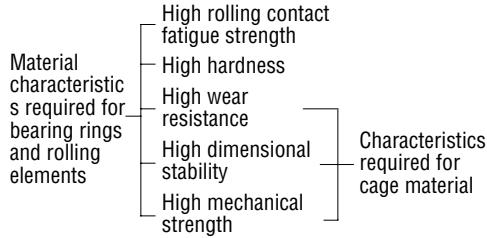

Other necessary characteristics, such as easy production, shock and heat resistance, and corrosion resistance, are required depending on individual applications.

#### 13.1 Materials for Bearing Rings and Rolling Elements

Primarily, high carbon chromium bearing steel (Table 13.1) is used for the bearing rings and rolling elements. Most NSK bearings are made of SUJ2 among the JIS steel types listed in Table 13.1, while the larger bearings generally use SUJ3. The chemical composition of SUJ2 is approximately the same as AISI 52100 specified in the USA, DIN 100 Cr6 in Germany, and BS 535A99 in England.

For bearings that are subjected to very severe shock loads, carburized low-carbon alloy steels such as chrome steel, chrome molybdenum steel, nickel chrome molybdenum steel, etc. are often used. Such steels, when they are carburized to the proper depth and have sufficient surface hardness, are more shock resistant than normal, through-hardened bearing steels because of the softer energy-absorbing core. The chemical composition of common carburized bearing steels is listed in Table 13.2.

**Table 13.1 Chemical Composition of High-Carbon Chromium Bearing Steel (Major Elements)**

Standard	Symbols	Chemical Composition (%)						
		C	Si	Mn	P	S	Cr	Mo
JIS G 4805	SUJ 2	0.95~1.10	0.15~0.35	Less than 0.50	Less than 0.025	Less than 0.025	1.30~1.60	Less than 0.08
	SUJ 3	0.95~1.10	0.40~0.70	0.90~1.15	Less than 0.025	Less than 0.025	0.90~1.20	Less than 0.08
	SUJ 4	0.95~1.10	0.15~0.35	Less than 0.50	Less than 0.025	Less than 0.025	1.30~1.60	0.10~0.25
ASTM A 295	52100	0.98~1.10	0.15~0.35	0.25~0.45	Less than 0.025	Less than 0.025	1.30~1.60	Less than 0.10

**Table 13.2 Chemical Composition of Carburizing Bearing Steels (Major Elements)**

Standard	Symbols	Chemical Composition (%)							
		C	Si	Mn	P	S	Ni	Cr	Mo
JIS G 4052	SCr 420 H	0.17~0.23	0.15~0.35	0.55~0.90	Less than 0.030	Less than 0.030	—	0.85~1.25	—
	SCM 420 H	0.17~0.23	0.15~0.35	0.55~0.90	Less than 0.030	Less than 0.030	—	0.85~1.25	0.15~0.35
	SNCM 220 H	0.17~0.23	0.15~0.35	0.60~0.95	Less than 0.030	Less than 0.030	0.35~0.75	0.35~0.65	0.15~0.30
	SNCM 420 H	0.17~0.23	0.15~0.35	0.40~0.70	Less than 0.030	Less than 0.030	1.55~2.00	0.35~0.65	0.15~0.30
JIS G 4103	SNCM 815	0.12~0.18	0.15~0.35	0.30~0.60	Less than 0.030	Less than 0.030	4.00~4.50	0.70~1.00	0.15~0.30
ASTM A 534	8620	0.18~0.23	0.15~0.35	0.70~0.90	Less than 0.035	Less than 0.040	0.40~0.70	0.40~0.60	0.15~0.25
	4320	0.17~0.22	0.15~0.35	0.45~0.65	Less than 0.035	Less than 0.040	1.65~2.00	0.40~0.60	0.20~0.30
	9310	0.08~0.13	0.15~0.35	0.45~0.65	Less than 0.035	Less than 0.040	3.00~3.50	1.00~1.40	0.08~0.15

**Table 13.3 Chemical Composition of High Speed Steel for Bearings Used at High Temperatures**

Standard	Symbols	Chemical Composition (%)											
		C	Si	Mn	P	S	Cr	Mo	V	Ni	Cu	Co	W
AISI	M50	0.77~0.85	Less than 0.25	Less than 0.35	Less than 0.015	Less than 0.015	3.75~4.25	4.00~4.50	0.90~1.10	Less than 0.10	Less than 0.10	Less than 0.25	Less than 0.25

NSK uses highly pure vacuum-degassed bearing steel containing a minimum of oxygen, nitrogen, and hydrogen compound impurities. The rolling fatigue life of bearings has been remarkably improved using this material combined with the appropriate heat treatment. For special purpose bearings, high temperature bearing steel, which has superior heat resistance, and stainless steel having good corrosion resistance may be used. The chemical composition of these special materials are given in Tables 13.3 and 13.4.

#### 13.2 Cage Materials

The low carbon steels shown in Table 13.5 are the main ones for the pressed cages for bearings. Depending on the purpose, brass or stainless steel may be used. For machined cages, high strength brass (Table 13.6) or carbon steel (Table 13.5) is used. Sometimes synthetic resin is also used.

**Table 13.4 Chemical Composition of Stainless Steel for Rolling Bearing (Major Elements)**

Standard	Symbols	Chemical Composition (%)						
		C	Si	Mn	P	S	Cr	Mo
JIS G 4303	SUS 440 C	0.95~1.20	Less than 1.00	Less than 1.00	Less than 0.040	Less than 0.030	16.00~18.00	Less than 0.75
SAE J 405	51440 C	0.95~1.20	Less than 1.00	Less than 1.00	Less than 0.040	Less than 0.030	16.00~18.00	Less than 0.75

**Table 13.5 Chemical Composition of Steel sheet and Carbon Steel for Cages (Major Elements)**

Classification	Standard	Symbols	Chemical Composition (%)				
			C	Si	Mn	P	S
Steel sheet and strip for pressed cages	JIS G 3141	SPCC	Less than 0.12	—	Less than 0.05	Less than 0.04	Less than 0.045
	BAS 361	SPB 2	0.13~0.20	Less than 0.04	0.25~0.60	Less than 0.03	Less than 0.030
	JIS G 3311	S 50 CM	0.47~0.53	0.15~0.35	0.60~0.90	Less than 0.03	Less than 0.035
Carbon steel for machined cages	JIS G 4051	S 25 C	0.22~0.28	0.15~0.35	0.30~0.60	Less than 0.03	Less than 0.035

**Remarks** BAS is Japanese Bearing Association Standard.

**Table 13.6 Chemical Composition of High Strength Brass for Machined Cages**

Standard	Symbols	Chemical Composition (%)								
		Cu	Zn	Mn	Fe	Al	Sn	Ni	Impurities	
									Pb	Si
JIS H 5102	HBsC 1	More than 55.0	Residual	Less than 1.5	0.5~1.5	0.5~1.5	Less than 1.0	Less than 1.0	Less than 0.4	Less than 0.1
JIS H 3250	C 6782	56.0~60.5	Residual	0.5~2.5	0.1~1.0	0.2~2.0	—	—	Less than 0.5	—

**Remarks** Improved HBsC 1 is also used.



## 14. BEARING HANDLING

### 14.1 Precautions for Proper Handling of Bearings

Since rolling bearings are high precision machine parts, they must be handled accordingly. Even if high quality bearings are used, their expected performance cannot be achieved if they are not handled properly. The main precautions to be observed are as follows:

#### (1) Keep Bearings and Surrounding Area Clean

Dust and dirt, even if invisible to the naked eye, have harmful effects on bearings. It is necessary to prevent the entry of dust and dirt by keeping the bearings and their environment as clean as possible.

#### (2) Careful Handling

Heavy shocks during handling may cause bearings to be scratched or otherwise damaged possibly resulting in their failure. Excessively strong impacts may cause brinelling, breaking, or cracking.

#### (3) Use Proper Tools

Always use the proper equipment when handling bearings and avoid general purpose tools.

#### (4) Prevent Corrosion

Since perspiration on the hands and various other contaminants may cause corrosion, keep the hands clean when handling bearings. Wear gloves if possible. Pay attention to rust of bearing caused by corrosive gasses.

### 14.2 Mounting

The method of mounting rolling bearings strongly affects their accuracy, life, and performance, so their mounting deserves careful attention. Their characteristics should first be thoroughly studied, and then they should be mounted in the proper manner. It is recommended that the handling procedures for bearings be fully investigated by the design engineers and that standards be established with respect to the following items:

- (1) Cleaning the bearings and related parts.
- (2) Checking the dimensions and finish of related parts.
- (3) Mounting procedures.
- (4) Inspection after mounting.
- (5) Supply of lubricants.

Bearings should not be unpacked until immediately before mounting. When using ordinary grease lubrication, the grease should be packed in the bearings without first cleaning them. Even in the case of ordinary oil lubrication, cleaning the bearings is not required. However, bearings for instruments or for high speed operation must first be cleaned with clean filtered oil in order to remove the anti-corrosion agent.

After the bearings are cleaned with filtered oil, they should be protected to prevent corrosion.

Prelubricated bearings must be used without cleaning. Bearing mounting methods depend on the bearing type and type of fit. As bearings are usually used on rotating shafts, the inner rings require a tight fit.

Bearings with cylindrical bores are usually mounted by pressing them on the shafts (press fit) or heating them to expand their diameter (shrink fit). Bearings with tapered bores can be mounted directly on tapered shafts or cylindrical shafts using tapered sleeves.

Bearings are usually mounted in housings with a loose fit. However, in cases where the outer ring has an interference fit, a press may be used. Bearings can be interference-fitted by cooling them before mounting using dry ice. In this case, a rust preventive treatment must be applied to the bearing because moisture in the air condenses on its surface.

#### 14.2.1 Mounting of Bearings with Cylindrical Bores

##### (1) Press Fits

Fitting with a press is widely used for small bearings. A mounting tool is placed on the inner ring as shown in Fig. 14.1 and the bearing is slowly pressed on the shaft with a press until the side of the inner ring rests against the shoulder of the shaft. The mounting tool must not be placed on the outer ring for press mounting, since the bearing may be damaged. Before mounting, applying oil to the fitted shaft surface is recommended for smooth insertion. The mounting method using a hammer should only be used for small ball bearings with minimally tight fits and when a press is not available. In the case of tight interference fits or for medium and large bearings, this method should not be used. Any time a hammer is used, a mounting tool must be placed on the inner ring.

When both the inner and outer rings of non-separable bearings, such as deep groove ball bearings, require tight-fit, a mounting tool is placed on both rings as shown in Fig. 14.2, and both rings are fitted at the same time using a screw or hydraulic press. Since the outer ring of self-aligning ball bearings may deflect a mounting tool such as that shown in Fig. 14.2 should always be used for mounting them.

In the case of separable bearings, such as cylindrical roller bearings and tapered roller bearings, the inner and outer rings may be mounted separately. Assembly of the inner and outer rings, which were previously mounted separately, should be done carefully to align the inner and outer rings correctly. Careless or forced assembly may cause scratches on the rolling contact surfaces.

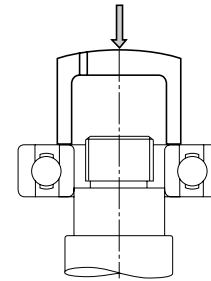

Fig. 14.1 Press Fitting Inner Ring

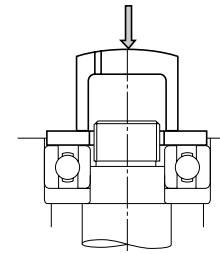

Fig. 14.2 Simultaneous Press Fitting of Inner and Outer Rings

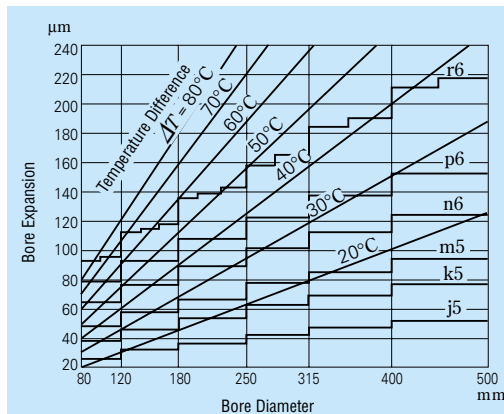

Fig. 14.3 Temperature and Thermal Expansion of Inner Ring

#### (2) Shrink Fits

Since press fitting large bearings requires a large force, a shrink fit is widely used. The bearings are first heated in oil to expand them before mounting.

This method prevents an excessive force from being imposed on the bearings and allows mounting them in a short time.

The expansion of the inner ring for various temperature differences and bearing sizes is shown in Fig. 14.3.

The precautions to follow when making shrink fits are as follows:

- (a) Do not heat bearings to more than 120°C.
- (b) Put the bearings on a wire net or suspend them in an oil tank in order to prevent them from touching the tank's bottom directly.
- (c) Heat the bearings to a temperature 20° to 30°C higher than the lowest temperature required for mounting without interference since the inner ring will cool a little during mounting.
- (d) After mounting, the bearings will shrink in the axial direction as well as the radial direction while cooling. Therefore, press the bearing firmly against the shaft shoulder using locating methods to avoid a clearance between the bearing and shoulder.

#### NSK Bearing Induction Heaters

Besides heating in oil, NSK Bearing Heaters, which use electromagnetic induction to heat bearings, are widely used. (Refer to Page C7.)

In NSK Bearing Heaters, electricity (AC) in a coil produces a magnetic field that induces a current inside the bearing that generates heat. Consequently, without using flames or oil uniform heating in a short time is possible, making bearing shrink fitting efficient and clean.

In the case of relatively frequent mounting and dismantling such as cylindrical roller bearings for roll necks of rolling mills and for railway journal boxes, induction heating should be used for mounting and dismantling inner rings.

14.2.2 Mounting of Bearings with Tapered Bores

Bearings with tapered bores are mounted on tapered shafts directly or on cylindrical shafts with adapters or withdrawal sleeves (Figs. 14.4 and 14.5). Large spherical roller bearings are often mounted using hydraulic pressure. Fig. 14.6 shows a bearing mounting utilizing a sleeve and hydraulic nut. Fig. 14.7 shows another mounting method. Holes are drilled in the sleeve which are used to feed oil under pressure to the bearing seat. As the bearing expands radially, the sleeve is inserted axially with adjusting bolts.

Spherical roller bearings should be mounted while checking their radial-clearance reduction and referring to the push-in amounts listed in Table 14.1. The radial clearance must be measured using clearance gauges. In this measurement, as shown in Fig. 14.8, the clearance for both rows of rollers must be measured simultaneously, and these two values should be kept roughly the same by adjusting the relative position of the outer and inner rings.

When a large bearing is mounted on a shaft, the outer ring may be deformed into an oval shape by its own weight. If the clearance is measured at the lowest part of the deformed bearing, the measured value may be bigger than the true value. If an incorrect radial internal clearance is obtained in this manner and the values in Table 14.1 are used, then the interference fit may

become too tight and the true residual clearance may become too small. In this case, as shown in Fig. 14.9, one half of the total clearance at points *a* and *b* (which are on a horizontal line passing through the bearing center) and *c* (which is at the lowest position of the bearing) may be used as the residual clearance.

When a self-aligning ball bearing is mounted on a shaft with an adapter, be sure that the residual clearance does not become too small. Sufficient clearance for easy alignment of the outer ring must be allowed.

14.3 Operation Inspection

After the mounting has been completed, a running test should be conducted to determine if the bearing has been mounted correctly. Small machines may be manually operated to assure that they rotate smoothly. Items to be checked include sticking due to foreign matter, visible flaws, uneven torque caused by improper mounting or an improper mounting surface, and excessive torque caused by an inadequate clearance, mounting error, or seal friction. If there are no abnormalities, powered operation may be started.

Table 14.1 Mounting of Spherical Roller Bearings with Tapered Bores

Units : mm

Bearing Bore Diameter <i>d</i>		Reduction in Radial Clearance		Axial Movement				Minimum Permissible Residual Clearance	
				Taper 1 : 12		Taper 1 : 30		CN	C3
over	incl	min	max	min	max	min	max		
30	40	0.025	0.030	0.40	0.45	—	—	0.010	0.025
40	50	0.030	0.035	0.45	0.55	—	—	0.015	0.030
50	65	0.030	0.035	0.45	0.55	—	—	0.025	0.035
65	80	0.040	0.045	0.60	0.70	—	—	0.030	0.040
80	100	0.045	0.055	0.70	0.85	1.75	2.15	0.035	0.050
100	120	0.050	0.060	0.75	0.90	1.9	2.25	0.045	0.065
120	140	0.060	0.070	0.90	1.1	2.25	2.75	0.055	0.080
140	160	0.065	0.080	1.0	1.3	2.5	3.25	0.060	0.100
160	180	0.070	0.090	1.1	1.4	2.75	3.5	0.070	0.110
180	200	0.080	0.100	1.3	1.6	3.25	4.0	0.070	0.110
200	225	0.090	0.110	1.4	1.7	3.5	4.25	0.080	0.130
225	250	0.100	0.120	1.6	1.9	4.0	4.75	0.090	0.140
250	280	0.110	0.140	1.7	2.2	4.25	5.5	0.100	0.150
280	315	0.120	0.150	1.9	2.4	4.75	6.0	0.110	0.160
315	355	0.140	0.170	2.2	2.7	5.5	6.75	0.120	0.180
355	400	0.150	0.190	2.4	3.0	6.0	7.5	0.130	0.200
400	450	0.170	0.210	2.7	3.3	6.75	8.25	0.140	0.220
450	500	0.190	0.240	3.0	3.7	7.5	9.25	0.160	0.240
500	560	0.210	0.270	3.4	4.3	8.5	11.0	0.170	0.270
560	630	0.230	0.300	3.7	4.8	9.25	12.0	0.200	0.310
630	710	0.260	0.330	4.2	5.3	10.5	13.0	0.220	0.330
710	800	0.280	0.370	4.5	5.9	11.5	15.0	0.240	0.390
800	900	0.310	0.410	5.0	6.6	12.5	16.5	0.280	0.430
900	1 000	0.340	0.460	5.5	7.4	14.0	18.5	0.310	0.470
1 000	1 120	0.370	0.500	5.9	8.0	15.0	20.0	0.360	0.530

**Remarks** The values for reduction in radial internal clearance are for bearings with CN clearance. For bearing with C3 Clearance, the maximum values listed should be used for the reduction in radial internal clearance.

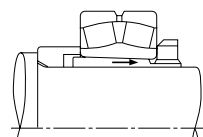

Fig. 14.4 Mounting with Adapter

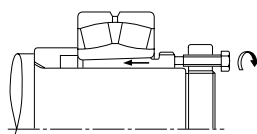

Fig. 14.5 Mounting with Withdrawal Sleeve

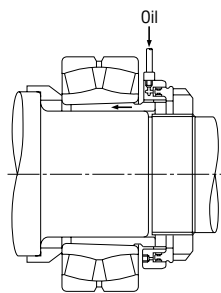

Fig. 14.6 Mounting with Hydraulic Nut

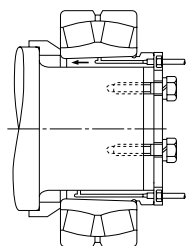

Fig. 14.7 Mounting with Special Sleeve and Hydraulic Pressure

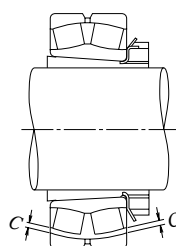

Fig. 14.8 Clearance Measurement of Spherical Roller Bearing

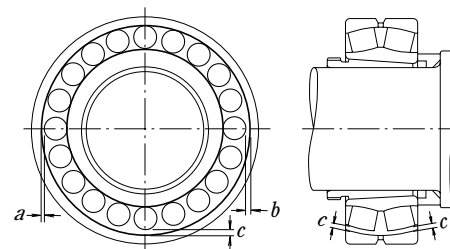

Fig. 14.9 Measuring Clearance in Large Spherical Roller Bearing

Large machines, which cannot be turned by hand, can be started after examination with no load, and the power immediately cutoff and the machine allowed to coast to a stop. Confirm that there is no abnormality such as vibration, noise, contact of rotating parts, etc. Powered operation should be started slowly without load and the operation should be observed carefully until it is determined that no abnormalities exist, then gradually increase the speed, load, etc. to their normal levels. Items to be checked during the test operation include the existence of abnormal noise, excessive rise of bearing temperature, leakage and contamination of lubricants, etc. If any abnormality is found during the test operation, it must be stopped immediately and the machine should be inspected. If necessary, the bearing should be dismantled for examination.

Although the bearing temperature can generally be estimated by the temperature of the outside surface of the housing, it is more desirable to directly measure the temperature of the outer ring using oil holes for access.

The bearing temperature should rise gradually to the steady state level within one to two hours after the operation starts. If the bearing or its mounting is improper, the bearing temperature may increase rapidly and become abnormally high. The cause of this abnormal temperature may be an excessive amount of lubricant, insufficient bearing clearance, incorrect

mounting, or excessive friction of the seals. In the case of high speed operation, an incorrect selection of bearing type or lubricating method may also cause an abnormal temperature rise. The sound of a bearing may be checked with a noise locator or other instruments. Abnormal conditions are indicated by a loud metallic sound, or other irregular noise, and the possible cause may include incorrect lubrication, poor alignment of the shaft and housing, or the entry of foreign matter into the bearing. The possible causes and countermeasures for irregularities are listed in Table 14.2.

**Table 14.2 Causes of and Countermeasures for Operating Irregularities**

Irregularities		Possible Causes	Countermeasures
Noise	Loud Metallic Sound (¹)	Abnormal Load	Improve the fit, internal clearance, preload, position of housing shoulder, etc.
		Incorrect mounting	Improve the machining accuracy and alignment of shaft and housing, accuracy of mounting method.
		Insufficient or improper Lubricant	Replenish the lubricant or select another lubricant.
		Contact of rotating parts	Modify the labyrinth seal, etc.
	Loud Regular Sound	Flaws, corrosion, or scratches on raceways	Replace or clean the bearing, improve the seals, and use clean lubricant.
		Brinelling	Replace the bearing and use care when handling bearings.
Irregular Sound	Flaking on raceway	Replace the bearing.	
	Excessive clearance	Improve the fit, clearance and preload.	
	Penetration of foreign particles	Replace or clean the bearing, improve the seals, and use clean lubricant.	
Abnormal Temperature Rise	Flaws or flaking on balls	Replace the bearing.	
	Excessive amount of lubricant	Reduce amount of lubricant, select stiffer grease.	
	Insufficient or improper lubricant	Replenish lubricant or select a better one.	
	Abnormal load	Improve the fit, internal clearance, preload, position of housing shoulder.	
	Incorrect mounting	Improve the machining accuracy and alignment of shaft and housing, accuracy of mounting, or mounting method.	
Vibration (Axial runout)	Creep on fitted surface, excessive seal friction	Correct the seals, replace the bearing, correct the fitting or mounting.	
	Brinelling	Replace the bearing and use care when handling bearings.	
	Flaking	Replace the bearing.	
	Incorrect mounting	Correct the squareness between the shaft and housing shoulder or side of spacer.	
Leakage or Discoloration of Lubricant	Penetration of foreign particles	Replace or clean the bearing, improve the seals.	
	Too much lubricant, Penetration by foreign matter or abrasion chips	Reduce the amount of lubricant, select a stiffer grease. Replace the bearing or lubricant. Clean the housing and adjacent parts.	

**Note** (¹) Intermittent squeal or high-pitch noise may be heard in medium- to large-sized cylindrical roller bearings or ball bearings that are operating under grease lubrication in low-temperature environments. Under such low-temperature conditions, bearing temperature will not rise resulting in fatigue nor is grease performance affected. Although intermittent squeal or high-pitch noise may occur under these conditions, the bearing is fully functional and can continue to be used. In the event that greater noise reduction or quieter running properties are needed, please contact your nearest NSK branch office.

**14.4 Dismounting**

A bearing may be removed for periodic inspection or for other reasons. If the removed bearing is to be used again or it is removed only for inspection, it should be dismantled as carefully as when it was mounted. If the bearing has a tight fit, its removal may be difficult. The means for removal should be considered in the original design of the adjacent parts of the machine. When dismantling, the procedure and sequence of removal should first be studied using the machine drawing and considering the type of mounting fit in order to perform the operation properly.

**14.4.1 Dismounting of Outer Rings**

In order to remove an outer ring that is tightly fitted, first place bolts in the push-out holes in the housing at several locations on its circumference as shown in Fig. 14.10, and remove the outer ring by uniformly tightening the bolts. These bolt holes should always be fitted with blank plugs when not being used for dismantling. In the case of separable bearings, such as tapered roller bearings, some notches should be made at several positions in the housing shoulder, as shown in Fig. 14.11, so the outer ring may be pressed out using a dismantling tool or by tapping it.

**14.4.2 Dismounting of Bearings with Cylindrical Bores**

If the mounting design allows space to press out the inner ring, this is an easy and fast method. In this case, the withdrawal force should be imposed only on the inner ring (Fig. 14.12). Withdrawal tools like those shown in Figs. 14.13 and 14.14 are often used.

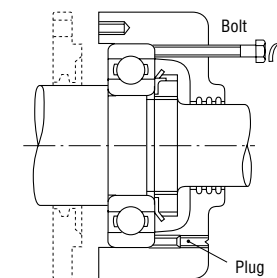

**Fig. 14.10 Removal of Outer Ring with Dismounting Bolts**

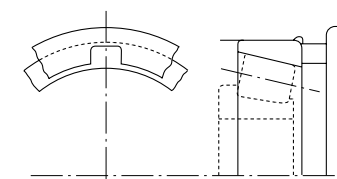

**Fig. 14.11 Removal Notches**

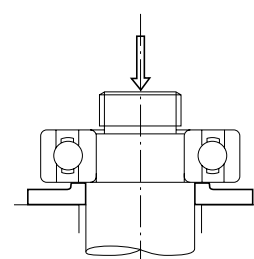

**Fig. 14.12 Removal of Inner Ring Using a Press**

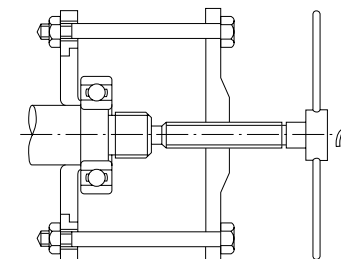

**Fig. 14.13 Removal of Inner Ring Using Withdrawal Tool (1)**

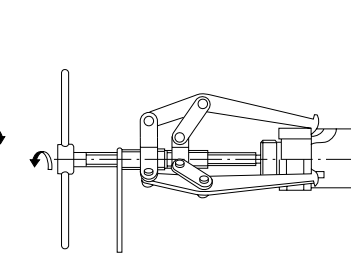

**Fig. 14.14 Removal of Inner Ring Using Withdrawal Tool (2)**

In both cases, the claws of the tools must substantially engage the face of the inner ring; therefore, it is advisable to consider the size of the shaft shoulder or to cut grooves in the shoulder to accommodate the withdrawal tools (Fig. 14.14).

The oil injection method is usually used for the withdrawal of large bearings. The withdrawal is achieved easily by mean of oil pressure applied through holes in the shaft. In the case of extra wide bearings, the oil injection method is used together with a withdrawal tool.

Induction heating is used to remove the inner rings of NU and NJ types of cylindrical roller bearings. The inner rings are expanded by brief local heating, and then withdrawn (Fig. 14.15). Induction heating is also used to mount several bearings of these types on a shaft.

**14.4.3 Dismounting of Bearings with Tapered Bores**

When dismantling relatively small bearings with adapters, the inner ring is held by a stop fastened to the shaft and the nut is loosened several turns. This is followed by hammering on the sleeve using a suitable tool as shown in Fig. 14.18. Fig. 14.16 shows one procedure for dismantling a withdrawal sleeve by tightening the removal nut. If this procedure is difficult, it may be possible to drill and tap bolt holes in the nut and withdraw the sleeve by tightening the bolts as shown in Fig. 14.17.

Large bearings may be withdrawn easily using oil pressure. Fig. 14.19 illustrates the removal of a bearing by forcing oil under pressure through a hole and groove in a tapered shaft to expand the inner ring. The bearing may suddenly move axially when the interference is relieved during this procedure so a stop nut is recommended for protection. Fig. 14.20 shows a withdrawal using a hydraulic nut.

**14.5 Inspection of Bearings**

**14.5.1 Bearing Cleaning**

When bearings are inspected, the appearance of the bearings should first be recorded and the amount and condition of the residual lubricant should be checked.

After the lubricant has been sampled for examination, the bearings should be cleaned. In general, light oil or kerosene may be used as a cleaning solution.

Dismounted bearings should first be given a preliminary cleaning followed by a finishing rinse. Each bath should be provided with a metal net to support the bearings in the oil without touching the sides or bottom of the tank. If the bearings are rotated with foreign matter in them during preliminary cleaning, the raceways may be damaged. The lubricant and other deposits should be removed in the oil bath during the initial rough cleaning with a brush or other means. After the bearing is relatively clean, it is given the finishing rinse. The finishing rinse should be done carefully with the bearing being rotated while immersed in the rinsing oil. It is necessary to always keep the rinsing oil clean.

**14.5.2 Inspection and Evaluation of Bearings**

After being thoroughly cleaned, bearings should be examined for the condition of their raceways and external surfaces, the amount of cage wear, the increase in internal clearance, and degradation of tolerances. These should be carefully checked, in addition to examination for possible damage or other abnormalities, in order to determine the possibility for its reuse.

In the case of small non-separable ball bearings, hold the bearing horizontally in one hand, and then rotate the outer ring to confirm that it turns smoothly.

Separable bearings such as tapered roller bearings may be checked by individually examining their rolling elements and the outer ring raceway.

Large bearings cannot be rotated manually; however, the rolling elements, raceway surfaces, cages, and contact surface of the ribs should be carefully examined visually. The more important a bearing is, the more carefully it should be inspected.

The determination to reuse a bearing should be made only after considering the degree of bearing wear, the function of the machine, the importance of the bearings in the machine, operating conditions, and the time until the next inspection. However, if any of the following defects exist, reuse is impossible and replacement is necessary.

- (a) When there are cracks in the inner or outer rings, rolling elements, or cage.
- (b) When there is flaking of the raceway or rolling elements.
- (c) When there is significant smearing of the raceway surfaces, ribs, or rolling elements.
- (d) When the cage is significantly worn or rivets are loose.
- (e) When there is rust or scoring on the raceway surfaces or rolling elements.
- (f) When there are any significant impact or brinell traces on the raceway surfaces or rolling elements.
- (g) When there is significant evidence of creep on the bore or the periphery of the outer ring.
- (h) When discoloration by heat is evident.
- (i) When significant damage to the seals or shields of grease sealed bearings has occurred.

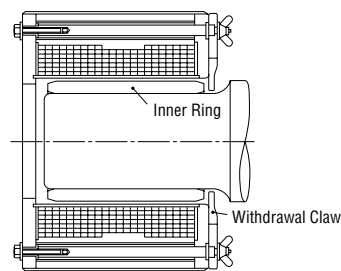

Fig. 14.15 Removal of Inner Ring Using Induction Heater

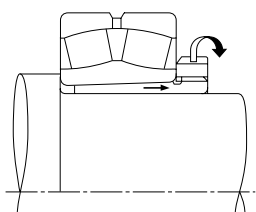

Fig. 14.16 Removal of Withdrawal Sleeve Using Withdrawal Nut (1)

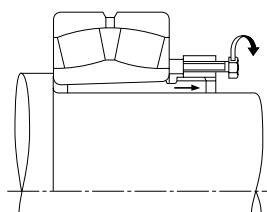

Fig. 14.17 Removal of Withdrawal Sleeve Using Withdrawal Nut (2)

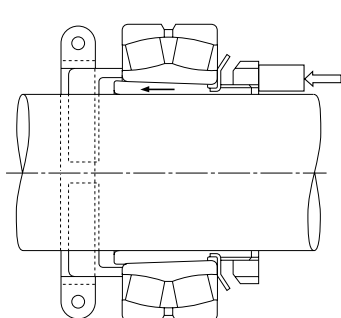

Fig. 14.18 Removal of Adapter with Stop and Axial Pressure

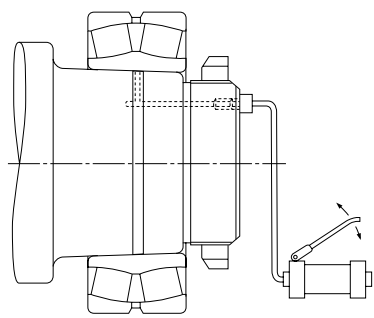

Fig. 14.19 Removal Using Oil Injection Hydraulic Pump

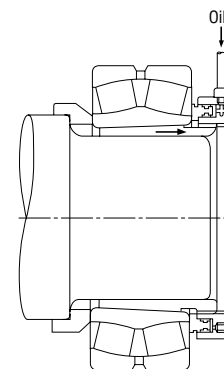

Fig. 14.20 Removal Using Hydraulic Nut



14.6 Maintenance and Inspection

14.6.1 Detecting and Correcting Irregularities

In order to maintain the original performance of a bearing for as long as possible, proper maintenance and inspection should be performed. If proper procedures are used, many bearing problems can be avoided and the reliability, productivity, and operating costs of the equipment containing the bearings are all improved. It is suggested that periodic maintenance be done following the procedure specified. This periodic maintenance encompasses the supervision of operating conditions, the supply or replacement of lubricants, and regular periodic inspection. Items that should be regularly checked during operation include bearing noise, vibration, temperature, and lubrication. If an irregularity is found during operation, the cause should be determined and the proper corrective actions should be taken after referring to Table 14.2. If necessary, the bearing should be dismantled and examined in detail. As for the procedure for dismantling and inspection, refer to Section 14.5, Inspection of Bearings.

NSK BEARING MONITOR (Bearing Abnormality Detector)

It is important during operation to detect signs of irregularities early before damage becomes severe. The NSK Bearing Monitor (see Page C5) is an instrument that checks the condition of bearings and gives a warning of any abnormality, or it stops a machine automatically in order to prevent serious trouble. In addition, it helps to improve maintenance and reduce its cost.

14.6.2 Bearing Failures and Countermeasures

In general, if rolling bearings are used correctly they will survive to their predicted fatigue life. However, they often fail prematurely due to avoidable mistakes. In contrast to fatigue life, this premature failure is caused by improper mounting, handling, or lubrication, entry of foreign matter, or abnormal heat generation. For instance, the causes of rib scoring, as one example of premature failure, may include insufficient lubrication, use of improper lubricant, faulty lubrication system, entry of foreign matter, bearing mounting error, excessive deflection of the shaft, or any combination of these. Thus, it is difficult to determine the real cause of some premature failures. If all the conditions at the time of failure and previous to the time of failure are known, including the application, the operating conditions, and environment; then by studying the nature of the failure and its probable causes, the possibility of similar future failures can be reduced. The most frequent types of bearing failure, along with their causes and corrective actions, are listed in Table 14.3.

Table 14.3 Causes and Countermeasure for Bearing Failures

Type of Failure	Probable Causes	Countermeasure
<b>Flaking</b>		
Flaking of one-side of the raceway of radial bearing.	Abnormal axial load.	A loose fit should be used when mounting the outer ring of free-end bearings to allow axial expansion of the shaft.
Flaking of the raceway in symmetrical pattern.	Out-of-roundness of the housing bore.	Correct the faulty housing.
Flaking pattern inclined relative to the raceway in radial ball bearings. Flaking near the edge of the raceway and rolling surfaces in roller bearings.	Improper mounting, deflection of shaft, inadequate tolerances for shaft and housing.	Use care in mounting and centering, select a bearing with a large clearance, and correct the shaft and housing shoulder.
Flaking of raceway with same spacing as rolling elements.	Large shock load during mounting, rusting while bearing is out of operation for prolonged period.	Use care in mounting and apply a rust preventive when machine operation is suspended for a long time.
Premature flaking of raceway and rolling elements.	Insufficient clearance, excessive load, improper lubrication, rust, etc.	Select proper fit, bearing clearance, and lubricant.
Premature flaking of duplex bearings.	Excessive preload.	Adjust the preload.

Type of Failure	Probable Causes	Countermeasure
<b>Scoring</b>		
Scoring or smearing between raceway and rolling surfaces.	Inadequate initial lubrication, excessively hard grease and high acceleration when starting.	Use a softer grease and avoid rapid acceleration.
Spiral scoring or smearing of raceway surface of thrust ball bearing.	Raceway rings are not parallel and excessive speed.	Correct the mounting, apply a preload, or select another bearing type.
Scoring or smearing between the end face of the rollers and guide rib.	Inadequate lubrication, incorrect mounting and large axial load.	Select proper lubricant and modify the mounting.
<b>Cracks</b>		
Crack in outer or inner ring.	Excessive shock load, excessive interference in fitting, poor surface cylindricity, improper sleeve taper, large fillet radius, development of thermal cracks and advancement of flaking.	Examine the loading conditions, modify the fit of bearing and sleeve. The fillet radius must be smaller than the bearing chamfer.
Crack in rolling element. Broken rib.	Advancement of flaking, shock applied to the rib during mounting or dropped during handling.	Be careful in handling and mounting.
Fractured cage.	Abnormal loading of cage due to incorrect mounting and improper lubrication.	Reduce the mounting error and review the lubricating method and lubricant.
<b>Indentations</b>		
Indentations in raceway in same pattern as rolling elements.	Shock load during mounting or excessive load when not rotating.	Use care in handling.
Indentations in raceway and rolling elements.	Foreign matter such as metallic chips or sand.	Clean the housing, improve the seals, and use a clean lubricant.
<b>Abnormal Wear</b>		
False brinelling (phenomenon similar to brinelling)	Vibration of the bearing without rotation during shipment or rocking motion of small amplitude.	Secure the shaft and housing, use oil as a lubricant and reduce vibration by applying a preload.
Fretting	Slight wear of the fitting surface.	Increase interference and apply oil.
Wearing of raceway, rolling elements, rib, and cage.	Penetration by foreign matter, incorrect lubrication, and rust.	Improve the seals, clean the housing, and use a clean lubricant.
Creep	Insufficient interference or insufficient tightening of sleeve.	Modify the fit or tighten the sleeve
<b>Seizure</b>		
Discoloration and melting of raceway, rolling elements, and ribs.	Insufficient clearance, incorrect lubrication, or improper mounting.	Review the internal clearance and bearing fit, supply an adequate amount of the proper lubricant and improve the mounting method and related parts.
<b>Electric Burn</b>		
Fluting or corrugations.	Melting due to electric arcing.	Install a ground wire to stop the flow of electricity or insulate the bearing.
<b>Corrosion &amp; Rust</b>		
Rust and corrosion of fitting surfaces and bearing interior.	Condensation of water from the air, or fretting. Penetration by corrosive substance (especially varnish-gas, etc).	Use care in storing and avoid high temperature and high humidity, treatment for rust prevention is necessary when operation is stopped for long time. Selection of varnish and grease.

# 15. TECHNICAL DATA

## DEFINITIONS OF SYMBOLS AND THEIR UNITS

	Page
<b>15.1 AXIAL DISPLACEMENT OF BEARINGS</b> .....	A 128~A 129
(1) Contact Angle and Axial Displacement of Deep Groove Ball Bearings and Angular Contact Ball Bearings .....	A 128~A 129
(2) Axial Load and Axial Displacement of Tapered Roller Bearings .....	A 128~A 129
<b>15.2 FITS</b> .....	A 130~A 133
(1) Surface Pressure, Maximum Stress on Fitted Surfaces and Expansion or Contraction of Raceway Diameter .....	A 130~A 131
(2) Interferences or Clearances for Shafts and Inner Rings .....	A 130~A 131
(3) Interferences or Clearances for Housing Bores and Outer Rings .....	A 130~A 133
<b>15.3 RADIAL AND AXIAL INTERNAL CLEARANCES</b> .....	A 132~A 133
(1) Radial and Axial Internal Clearances for Single-Row Deep Groove Ball Bearings .....	A 132~A 133
(2) Radial and Axial Internal Clearances for Double-Row Angular Contact Ball Bearings .....	A 132~A 133
<b>15.4 PRELOAD AND STARTING TORQUE</b> .....	A 134~A 135
(1) Axial Load and Starting Torque of Tapered Roller Bearings .....	A 134
(2) Preload and Starting Torque of Angular Contact Ball Bearings and Double-Direction Angular Contact Thrust Ball Bearings .....	A 134~A 135
<b>15.5 COEFFICIENTS OF FRICTION AND OTHER BEARING DATA</b> .....	A 136~A 137
(1) Bearing Types and Their Coefficients of Friction .....	A 136
(2) Circumferential Speed of Rolling Elements about Their Centers and Bearing Center .....	A 136
(3) Radial Internal Clearance and Fatigue Life .....	A 136~A 137
<b>15.6 BRANDS AND PROPERTIES OF LUBRICATING GREASES</b> .....	A 138~A 141

Symbols	Nomenclature	Units	Symbols	Nomenclature	Units
$a$	Contact Ellipse Major Axis	(mm)	$n_a$	Rotating Speed of Rolling Elements	(rpm)
$b$	Contact Ellipse Major Axis	(mm)	$n_c$	Revolving Speed of Rolling Elements (Cape Speed)	(rpm)
$C_r$	Basic Dynamic Load Rating of Radial Bearings	(N) {kgf}	$n_e$	Speed of Outer Ring	(rpm)
$C_{0r}$	Basic Static Load Rating of Radial Bearings	(N) {kgf}	$n_i$	Speed of Inner Ring	(rpm)
$C_a$	Basic Dynamic Load Rating of Thrust Bearings	(N) {kgf}	$p_m$	Surface Pressure on Fitted Surface	(MPa) {kgf/mm <sup>2</sup> }
$C_{0a}$	Basic Static Load Rating of Thrust Bearings	(N) {kgf}	$P$	Bearing Load	(N) {kgf}
$d$	Shaft Diameter, Nominal Bearing Bore Diameter	(mm)	$Q$	Rolling Element Load	(N) {kgf}
$D$	Housing Bore Diameter, Nominal Bearing Outside Diameter	(mm)	$r_e$	Groove Radius of Outer Ring	(mm)
$D_e$	Outer Ring Raceway Diameter	(mm)	$r_i$	Groove Radius of Inner Ring	(mm)
$D_i$	Inner Ring Raceway Diameter	(mm)	$v_a$	Circumferential Speed of Rolling Element about Its Center	(m/sec)
$D_o$	Housing Outside Diameter	(mm)	$v_c$	Circumferential Speed of Rolling Element about Bearing Center	(m/sec)
$D_{pw}$	Rolling Element Pitch Diameter	(mm)	$Z$	Number of Rolling Elements per Row	
$D_w$	Nominal Rolling Element Diameter	(mm)	$\alpha$	Contact Angle (when axial load is applied on Radial Ball Bearing)	(°)
$e$	Contact Position of Tapered Roller End Face with Rib	(mm)	$\alpha_0$	Initial Contact Angle (Geometri) (when inner and outer rings of Angular Contact Ball Bearings are pushed axially)	(°)
$E$	Modulus of Longitudinal Elasticity (Bearing Steel) 208 000 MPa { 21 200kgf/mm <sup>2</sup> }		$\alpha_R$	Initial Contact Angle (Geometric) (when inner and outer rings Angular Contact Ball Bearing are pushed radially)	(°)
$E(k)$	Complete elliptic integral of the 2nd kind for which the population parameter is $k = \sqrt{1 - \left(\frac{b}{a}\right)^2}$		$\beta$	1/2 of Conical Angle of Roller	(°)
$f_0$	factor which depends on the geometry of the bearing components and on the applicable stress level		$\delta_a$	Relative Axial Displacement of Inner and Outer Rings	(mm)
$f(\epsilon)$	Function of $\epsilon$		$\Delta_a$	Axial Internal Clearance	(mm)
$F_a$	Axial Load, Preload	(N) {kgf}	$\Delta d$	Effective Interference of Inner Ring and Shaft	(mm)
$F_r$	Radial Load	(N) {kgf}	$\Delta r$	Radial Internal Clearance	(mm)
$h$	$D_e/D$		$\Delta D$	Effective Interference of Outer Ring and Housing	(mm)
$h_0$	$D/D_0$		$\Delta D_e$	Contraction of Outer Ring Raceway Diameter due to Fit	(mm)
$k$	$d/D_i$		$\Delta D_i$	Expansion of Inner Ring Raceway Diameter due to Fit	(mm)
$K$	Constant Determined by Internal Design of Bearing		$\epsilon$	Load Factor	
$L$	Fatigue Life when Effective Clearance is 0		$\mu$	Coefficient of Dynamic Friction of Rolling Bearing	
$L_{we}$	Effective Leng of Roller	(mm)	$\mu_e$	Coefficient of Friction between Roller End Face and Rib	
$L_\epsilon$	Fatigue Life when Effective Clearance is $\Delta$		$\mu_s$	Coefficient of Sliding Friction	
$m_0$	Distance between Centers of Curvature of Inner and Outer Rings $r_i + r_e - D_w$	(mm)	$\sigma_{tmax}$	Maximum Stress on Fitted Surfaces	(MPa) {kgf/mm <sup>2</sup> }
$M$	Frictional Torque	(N·mm) {kgf·mm}			
$M_s$	Spin Friction	(N·mm) {kgf·mm}			



15.1 Axial Displacement of Bearings

(1) Contact Angle  $\alpha$  and Axial Displacement  $\delta_a$  of Deep Groove Ball Bearing and Angular Contact Ball Bearings

(Figs. 15.1 to 15.3)

$$\delta_a = \frac{0.00044}{\sin \alpha} \left( \frac{Q^2}{D_w} \right)^{\frac{1}{3}} \dots\dots\dots (N) \left. \vphantom{\frac{0.00044}{\sin \alpha}} \right\} (\text{mm})$$

$$\delta_a = \frac{0.002}{\sin \alpha} \left( \frac{Q^2}{D_w} \right)^{\frac{1}{3}} \dots\dots\dots \{\text{kgf}\} \left. \vphantom{\frac{0.002}{\sin \alpha}} \right\}$$

$$Q = \frac{F_a}{Z \sin \alpha} \dots\dots\dots (N), \{\text{kgf}\}$$

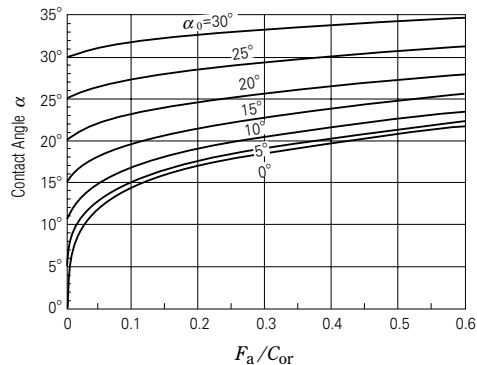

Fig. 15.1  $F_a/C_{Or}$  and Contact Angle of Deep Groove and Angular Contact Ball Bearings

(2) Axial Load  $F_a$  and Axial Displacement  $\delta_a$  of Tapered Roller Bearings

$$\delta_a = \frac{0.000077 F_a^{0.9}}{(\sin \alpha)^{1.9} Z^{0.9} L_{we}^{0.8}} \dots\dots\dots (N) \left. \vphantom{\frac{0.000077 F_a^{0.9}}{(\sin \alpha)^{1.9} Z^{0.9} L_{we}^{0.8}}} \right\} (\text{mm})$$

$$\delta_a = \frac{0.0006 F_a^{0.9}}{(\sin \alpha)^{1.9} Z^{0.9} L_{we}^{0.8}} \dots\dots\dots \{\text{kgf}\} \left. \vphantom{\frac{0.0006 F_a^{0.9}}{(\sin \alpha)^{1.9} Z^{0.9} L_{we}^{0.8}}} \right\}$$

**Remarks:**  
Actual axial displacement may vary depending on the shaft/housing thickness, material, and fitting interference with the bearing. Please contact NSK about such factors of axial displacement which are not discussed in detail in this catalog.

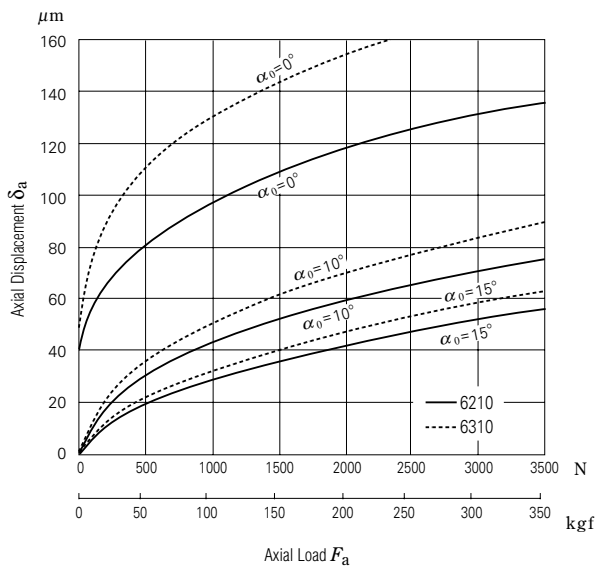

Fig. 15.2 Axial Load and Axial Displacement of Deep Groove Ball Bearings

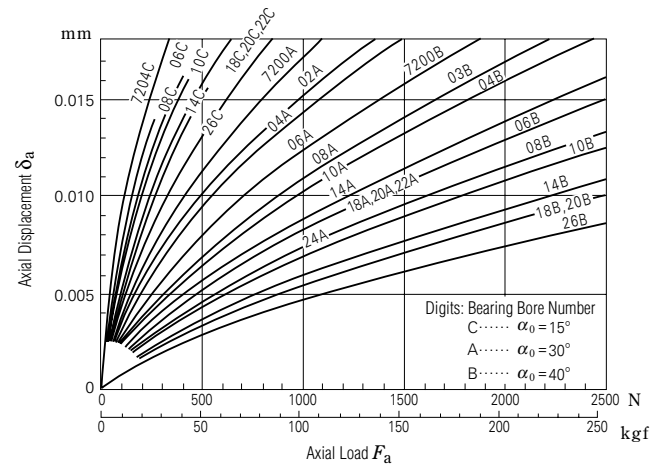

Fig. 15.3 Axial Load and Axial Displacement of Angular Contact Ball Bearings

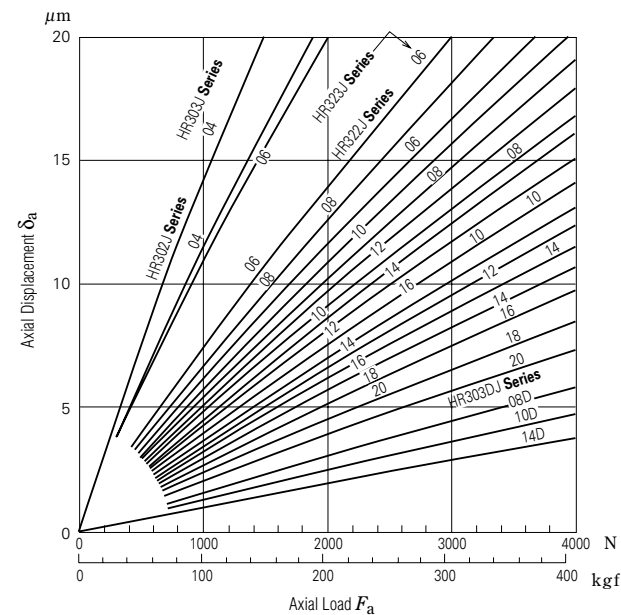

Fig. 15.4 Axial Load and Axial Displacement of Tapered Roller Bearings

15.2 Fits

- (1) Surface Pressure  $p_m$ , Maximum Stress  $\sigma_{tmax}$  on Fitted Surfaces and Expansion of Inner Ring Raceway Diameter  $\Delta D_i$  or Contraction of Outer Ring Raceway Diameter  $\Delta D_e$  (Table 15.1, Figs. 15.5 and 15.6)
- (2) Interferences or Clearances of Shafts and Inner Rings (Table 15.2)
- (3) Interferences or Clearances of Housing Bores and Outer Rings (Table 15.3)

Table 15.1 Surface Pressure, Maximum Stress on Fitted Surfaces and Expansion or Contraction

Items	Shaft & Inner Ring	Housing & Bore & Outer Ring
Surface Pressure $p_m$ (MPa) {kgf/mm <sup>2</sup> }	(In case of solid shaft) $p_m = \frac{E}{2} \frac{\Delta d}{2} (1 - k^2)$	In case of housing outside dia. $D_0 \neq \infty$ $p_m = \frac{E}{2} \frac{\Delta D}{D} \frac{(1 - k^2)(1 - h_0^2)}{1 - h^2 h_0^2}$ In case $D_0 = \infty$ $p_m = \frac{E}{2} \frac{\Delta D}{D} (1 - h^2)$
Maximum stress $\sigma_{tmax}$ (MPa) {kgf/mm <sup>2</sup> }	Maximum circumferential stress on fitted surface of inner ring bore is $\sigma_{tmax} = p_m \frac{1 + k^2}{1 - k^2}$	Maximum circumferential stress on outer ring bore surface is $\sigma_{tmax} = p_m \frac{2}{1 - h^2}$
Expansion of inner ring raceway dia. $\Delta D_i$ (mm) Contraction of outer ring raceway dia. $\Delta D_e$ (mm)	In case of solid shaft $\Delta D_i = \Delta d \cdot k$	In case $D_0 \neq \infty$ $\Delta D_e = \Delta D \cdot h \frac{1 - h_0^2}{1 - h^2 h_0^2}$ In case $D_0 = \infty$ $\Delta D_e = \Delta D \cdot h$

**Remarks** The modulus of longitudinal elasticity and Poisson's ratio for the shaft and housing material are the same as those for inner and outer rings.

**Reference** 1MPa=1N/mm<sup>2</sup>=0.102kgf/mm<sup>2</sup>

Table 15.2 Interferences or Clearances

Size Classification (mm)	Single Plane Mean Bore Dia. Deviation (Normal) $\Delta d_{mp}$		Interferences or Clearances for															
			f6		g5		g6		h5		h6		js5		j5			
			Clearance	Interference	Clearance	Interference	Clearance	Interference	Clearance	Interference	Clearance	Interference	Clearance	Interference	Clearance	Interference		
over incl	high over	max	min	max	max	max	max	max	max	max	max	max	max	max	max	max	max	
<b>3 6</b>	0 - 8	18	2	9	4	12	4	5	8	8	8	—	—	—	—	—	—	
<b>6 10</b>	0 - 8	22	5	11	3	14	3	6	8	9	8	3	11	2	12	12	12	
<b>10 18</b>	0 - 8	27	8	14	2	17	2	8	8	11	8	4	12	3	13	13	13	
<b>18 30</b>	0 - 10	33	10	16	3	20	3	9	10	13	10	4.5	14.5	4	15	15	15	
<b>30 50</b>	0 - 12	41	13	20	3	25	3	11	12	16	12	5.5	17.5	5	18	18	18	
<b>50 65</b>	0 - 15	49	15	23	5	29	5	13	15	19	15	6.5	21.5	7	21	21	21	
<b>65 80</b>	0 - 15	49	15	23	5	29	5	13	15	19	15	6.5	21.5	7	21	21	21	
<b>80 100</b>	0 - 20	58	16	27	8	34	8	15	20	22	20	7.5	27.5	9	26	26	26	
<b>100 120</b>	0 - 20	58	16	27	8	34	8	15	20	22	20	7.5	27.5	9	26	26	26	
<b>120 140</b>	0 - 25	68	18	32	11	39	11	18	25	25	25	9	34	11	32	32	32	
<b>140 160</b>	0 - 25	68	18	32	11	39	11	18	25	25	25	9	34	11	32	32	32	
<b>160 180</b>	0 - 25	68	18	32	11	39	11	18	25	25	25	9	34	11	32	32	32	
<b>180 200</b>	0 - 30	79	20	35	15	44	15	20	30	29	30	10	40	13	37	37	37	
<b>200 225</b>	0 - 30	79	20	35	15	44	15	20	30	29	30	10	40	13	37	37	37	
<b>225 250</b>	0 - 30	79	20	35	15	44	15	20	30	29	30	10	40	13	37	37	37	
<b>250 280</b>	0 - 35	88	21	40	18	49	18	23	35	32	35	11.5	46.5	16	42	42	42	
<b>280 315</b>	0 - 35	88	21	40	18	49	18	23	35	32	35	11.5	46.5	16	42	42	42	
<b>315 355</b>	0 - 40	98	22	43	22	54	22	25	40	36	40	12.5	52.5	18	47	47	47	
<b>355 400</b>	0 - 40	98	22	43	22	54	22	25	40	36	40	12.5	52.5	18	47	47	47	
<b>400 450</b>	0 - 45	108	23	47	25	60	25	27	45	40	45	13.5	58.5	20	52	52	52	
<b>450 500</b>	0 - 45	108	23	47	25	60	25	27	45	40	45	13.5	58.5	20	52	52	52	

**Remarks** 1. The figures for tolerance classes where stress caused by the fitting of the shaft and inner ring becomes excessive are omitted.  
2. The tolerance range js is now recommended instead of j.

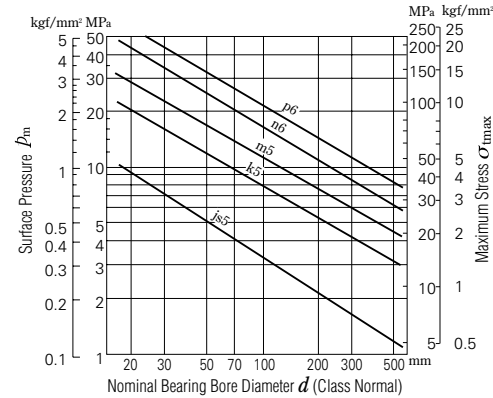

Fig. 15.5 Surface Pressure  $p_m$  and Maximum Stress  $\sigma_{tmax}$  for Average Fitting Interference

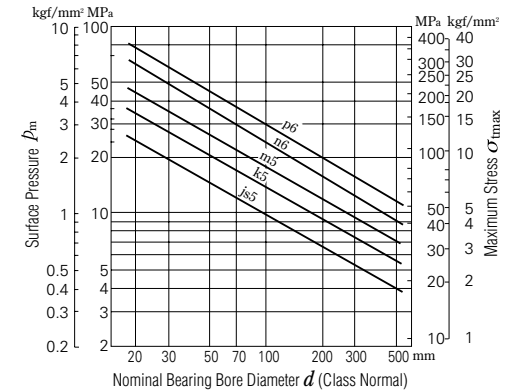

Fig. 15.6 Surface Pressure  $p_m$  and Maximum Stress  $\sigma_{tmax}$  for Maximum Fitting Interference

of Shafts and Inner Rings

Units :  $\mu m$

Each Fitting Class																				Size Classification (mm)	
js6		j6		k5		k6		m5		m6		n6		p6		r6					
Clearance	Interference	Clearance	Interference	Interference	Interference	Interference	Interference	Interference	Interference	Interference	Interference	Interference	Interference	Interference	Interference	Interference					
max	max	max	max	min	max	min	max	min	max	min	max	min	max	min	max	min	max	over	incl		
—	—	—	—	—	—	—	—	—	—	—	—	—	—	—	—	—	—	<b>3 6</b>	<b>6 10</b>		
4.5	12.5	2	15	—	—	—	—	—	—	—	—	—	—	—	—	—	—	<b>10 18</b>	<b>18 30</b>		
5.5	13.5	3	16	—	—	—	—	—	—	—	—	—	—	—	—	—	—	<b>30 50</b>	<b>50 65</b>		
6.5	16.5	4	19	2	21	2	25	—	—	—	—	—	—	—	—	—	—	<b>65 80</b>	<b>80 100</b>		
8	20	5	23	2	25	2	30	9	32	9	37	—	—	—	—	—	—	<b>100 120</b>	<b>120 140</b>		
9.5	24.5	7	27	2	30	2	36	11	39	11	45	—	—	—	—	—	—	<b>140 160</b>	<b>160 180</b>		
9.5	24.5	7	27	2	30	2	36	11	39	11	45	20	54	—	—	—	—	<b>180 200</b>	<b>200 225</b>		
11	31	9	33	3	38	3	45	13	48	13	55	23	65	37	79	—	—	<b>225 250</b>	<b>250 280</b>		
11	31	9	33	3	38	3	45	13	48	13	55	23	65	37	79	—	—	<b>280 315</b>	<b>315 355</b>		
12.5	37.5	11	39	3	46	3	53	15	58	15	65	27	77	43	93	63	113	<b>355 400</b>	<b>400 450</b>		
12.5	37.5	11	39	3	46	3	53	15	58	15	65	27	77	43	93	63	113	<b>450 500</b>	<b>500 550</b>		
12.5	37.5	11	39	3	46	3	53	15	58	15	65	27	77	43	93	68	118				
14.5	44.5	13	46	4	54	4	63	17	67	17	76	31	90	50	109	77	136				
14.5	44.5	13	46	4	54	4	63	17	67	17	76	31	90	50	109	80	139				
14.5	44.5	13	46	4	54	4	63	17	67	17	76	31	90	50	109	84	143				
16	51	16	51	4	62	4	71	20	78	20	87	34	101	56	123	94	161				
16	51	16	51	4	62	4	71	20	78	20	87	34	101	56	123	98	165				
18	58	18	58	4	69	4	80	21	86	21	97	37	113	62	138	108	184				
18	58	18	58	4	69	4	80	21	86	21	97	37	113	62	138	114	190				
20	65	20	65	5	77	5	90	23	95	23	108	40	125	68	153	126	211				
20	65	20	65	5	77	5	90	23	95	23	108	40	125	68	153	132	217				

Table 15. 3 Interferences or

Size Classification (mm)		Single Plane Mean O. D. Deviation (Normal) $\Delta D_{mp}$		Interferences or Clearances for													
				G7		H6		H7		H8		J6		JS6		J7	
				Clearance		Clearance		Clearance		Clearance		Clearance	Interference	Clearance	Interference	Clearance	Interference
over	incl	high	low	max	min	max	min	max	min	max	min	max	min	max	max	min	
<b>6</b>	<b>10</b>	0	- 8	28	5	17	0	23	0	30	0	13	4	12.5	4.5	16	7
<b>10</b>	<b>18</b>	0	- 8	32	6	19	0	26	0	35	0	14	5	13.5	5.5	18	8
<b>18</b>	<b>30</b>	0	- 9	37	7	22	0	30	0	42	0	17	5	15.5	6.5	21	9
<b>30</b>	<b>50</b>	0	- 11	45	9	27	0	36	0	50	0	21	6	19	8	25	11
<b>50</b>	<b>80</b>	0	- 13	53	10	32	0	43	0	59	0	26	6	22.5	9.5	31	12
<b>80</b>	<b>120</b>	0	- 15	62	12	37	0	50	0	69	0	31	6	26	11	37	13
<b>120</b>	<b>150</b>	0	- 18	72	14	43	0	58	0	81	0	36	7	30.5	12.5	44	14
<b>150</b>	<b>180</b>	0	- 25	79	14	50	0	65	0	88	0	43	7	37.5	12.5	51	14
<b>180</b>	<b>250</b>	0	- 30	91	15	59	0	76	0	102	0	52	7	44.5	14.5	60	16
<b>250</b>	<b>315</b>	0	- 35	104	17	67	0	87	0	116	0	60	7	51	16	71	16
<b>315</b>	<b>400</b>	0	- 40	115	18	76	0	97	0	129	0	69	7	58	18	79	18
<b>400</b>	<b>500</b>	0	- 45	128	20	85	0	108	0	142	0	78	7	65	20	88	20
<b>500</b>	<b>630</b>	0	- 50	142	22	94	0	120	0	160	0	—	—	72	22	—	—
<b>630</b>	<b>800</b>	0	- 75	179	24	125	0	155	0	200	0	—	—	100	25	—	—
<b>800</b>	<b>1000</b>	0	-100	216	26	156	0	190	0	240	0	—	—	128	28	—	—

Note (\*) Indicates the minimum interference  
Remarks The tolerance range JS is now recommended instead of J.

Clearances of Housing Bores and Outer Rings

Units :  $\mu\text{m}$

Each Fitting Class																				Size Classification (mm)	
JS7		K6		K7		M6		M7		N6		N7		P6		P7					
Clearance	Interference	Clearance	Interference	Clearance	Interference	Clearance	Interference	Clearance	Interference	Clearance	Interference	Clearance	Interference	Interference	Interference	Interference	Interference				
max	max	max	max	max	max	max	max	max	max	max	max	max	max	max	max	max	min	max	over	incl	
15	7	10	7	13	10	5	12	8	15	1	16	4	19	4	21	1	24	<b>6</b>	<b>10</b>		
17	9	10	9	14	12	4	15	8	18	1*	20	3	23	7	26	3	29	<b>10</b>	<b>18</b>		
19	10	11	11	15	15	5	17	9	21	2*	24	2	28	9	31	5	35	<b>18</b>	<b>30</b>		
23	12	14	13	18	18	7	20	11	25	1*	28	3	33	10	37	6	42	<b>30</b>	<b>50</b>		
28	15	17	15	22	21	8	24	13	30	1*	33	4	39	13	45	8	51	<b>50</b>	<b>80</b>		
32	17	19	18	25	25	9	28	15	35	1*	38	5	45	15	52	9	59	<b>80</b>	<b>120</b>		
38	20	22	21	30	28	10	33	18	40	2*	45	6	52	18	61	10	68	<b>120</b>	<b>150</b>		
45	20	29	21	37	33	17	33	25	40	5	45	13	52	11	61	3	68	<b>150</b>	<b>180</b>		
53	23	35	24	43	33	22	37	30	46	8	51	16	60	11	70	3	79	<b>180</b>	<b>250</b>		
61	26	40	27	51	36	26	41	35	52	10	57	21	66	12	79	1	88	<b>250</b>	<b>315</b>		
68	28	47	29	57	40	30	46	40	57	14	62	24	73	11	87	1	98	<b>315</b>	<b>400</b>		
76	31	53	32	63	45	35	50	45	63	18	67	28	80	10	95	0	108	<b>400</b>	<b>500</b>		
85	35	50	44	50	70	24	70	24	96	6	88	6	114	28	122	28	148	<b>500</b>	<b>630</b>		
115	40	75	50	75	80	45	80	45	110	25	100	25	130	13	138	13	168	<b>630</b>	<b>800</b>		
145	45	100	56	100	90	66	90	66	124	44	112	44	146	0	156	0	190	<b>800</b>	<b>1000</b>		

15.3 Radial and Axial Internal Clearances

(1) Radial Internal Clearance  $\Delta_r$  and Axial Internal Clearance  $\Delta_a$  in Single-Row Deep Groove Ball Bearings (Fig. 15.7)

$$\Delta_a \doteq K \Delta_r^{\frac{1}{2}} \quad (\text{mm})$$

where

$$K = 2 (r_e + r_i - D_w)^{\frac{1}{2}}$$

(2) Radial Internal Clearance  $\Delta_r$  and Axial Internal Clearance  $\Delta_a$  in Double-Row Angular Contact Ball Bearings (Fig. 15.8)

$$\Delta_a = 2 \sqrt{m_0^2 - (m_0 \cos \alpha_R - \frac{\Delta_r}{2})^2} - 2 m_0 \sin \alpha_R \quad (\text{mm})$$

Table 15. 4 Constant K

Bore No.	Values of K			
	160XX	60XX	62XX	63XX
<b>00</b>	—	—	0.93	1.14
<b>01</b>	0.80	0.80	0.93	1.06
<b>02</b>	0.80	0.93	0.93	1.06
<b>03</b>	0.80	0.93	0.99	1.11
<b>04</b>	0.90	0.96	1.06	1.07
<b>05</b>	0.90	0.96	1.06	1.20
<b>06</b>	0.96	1.01	1.07	1.19
<b>07</b>	0.96	1.06	1.25	1.37
<b>08</b>	0.96	1.06	1.29	1.45
<b>09</b>	1.01	1.11	1.29	1.57
<b>10</b>	1.01	1.11	1.33	1.64
<b>11</b>	1.06	1.20	1.40	1.70
<b>12</b>	1.06	1.20	1.50	2.09
<b>13</b>	1.06	1.20	1.54	1.82
<b>14</b>	1.16	1.29	1.57	1.88
<b>15</b>	1.16	1.29	1.57	1.95
<b>16</b>	1.20	1.37	1.64	2.01
<b>17</b>	1.20	1.37	1.70	2.06
<b>18</b>	1.29	1.44	1.76	2.11
<b>19</b>	1.29	1.44	1.82	2.16
<b>20</b>	1.29	1.44	1.88	2.25
<b>21</b>	1.37	1.54	1.95	2.32
<b>22</b>	1.40	1.64	2.01	2.40
<b>24</b>	1.40	1.64	2.06	2.40
<b>26</b>	1.54	1.70	2.11	2.49
<b>28</b>	1.54	1.70	2.11	2.59
<b>30</b>	1.57	1.76	2.11	2.59

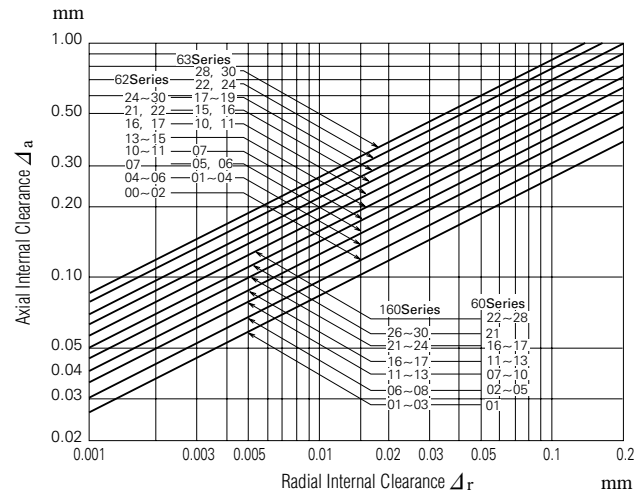

Fig. 15.7  $\Delta_r$  and  $\Delta_a$  in Single-Row Deep Groove Ball Bearings

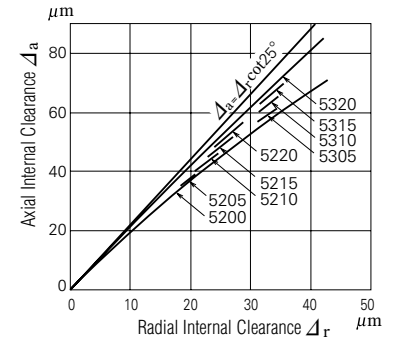

Fig. 15.8  $\Delta_r$  and  $\Delta_a$  in Double-Row Angular Contact Ball Bearings (52, 53 Series)

15.4 Preload and Starting Torque

(1) Axial Load  $F_a$  and Starting Torque  $M$  of Tapered Roller Bearings (Figs. 15.9 and 15.10)

$$M = e \mu_e F_a \cos\beta \quad (\text{N}\cdot\text{mm}), \{\text{kgf}\cdot\text{mm}\}$$

where

$$\mu_e : 0.20$$

When bearings with the same number are used in opposition, the torque  $M$  caused by the preload becomes  $2M$ .

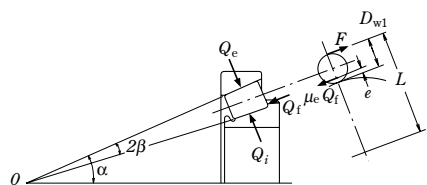

Fig. 15.9 Relation between  $e$  and  $\beta$

(2) Preload  $F_a$  and Starting Torque  $M$  of Angular Contact Ball Bearings and Double-Direction Angular Contact Thrust Ball Bearings (Figs. 15.11 and 15.12)

$$M = M_s Z \sin\alpha \quad (\text{N}\cdot\text{mm}), \{\text{kgf}\cdot\text{mm}\}$$

where  $M_s$  is spin friction

$$M_s = \frac{3}{8} \mu_s Q a E(k) \quad (\text{N}\cdot\text{mm}), \{\text{kgf}\cdot\text{mm}\}$$

where

$$\mu_s = 0.15$$

When bearings with the same number are used in opposition, the torque  $M$  caused by the preload becomes  $2M$ .

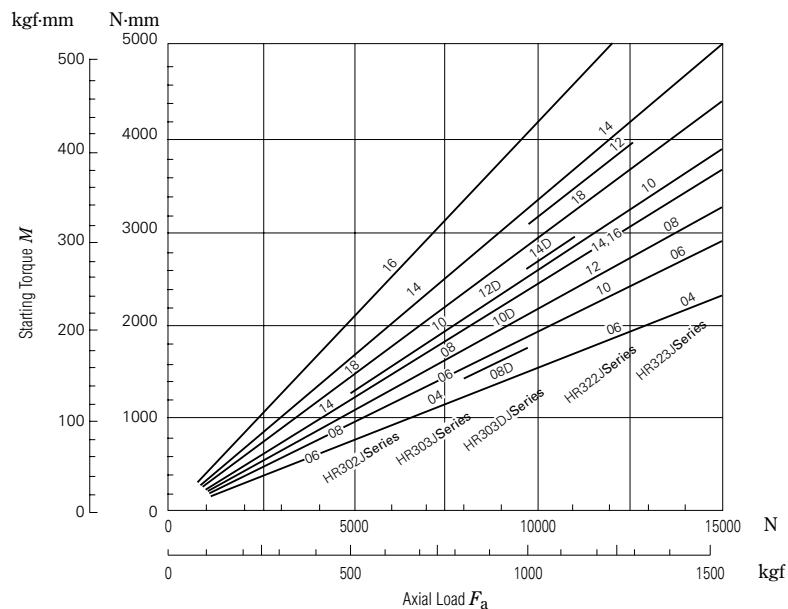

Fig. 15.10 Relation between Axial Load and Starting Torque of Tapered Roller Bearings

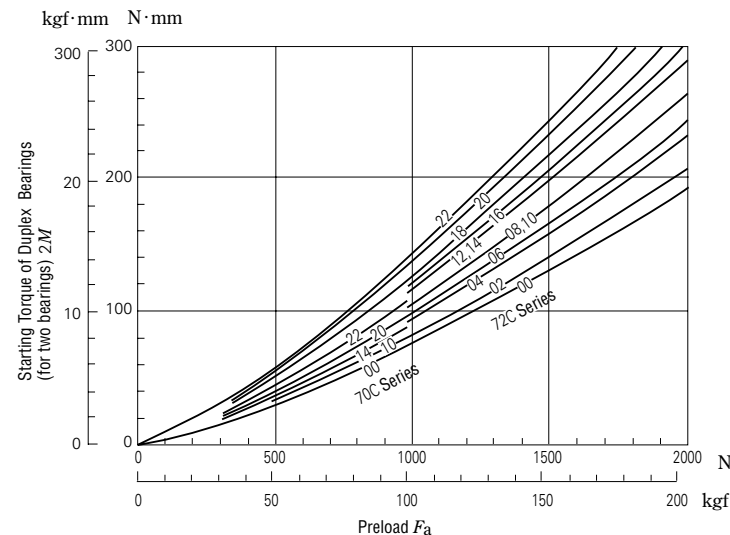

Fig. 15.11 Preload and Starting Torque for Back-to-Back or Face-to-Face Arrangements of Angular Contact Ball Bearings ( $\alpha = 15^\circ$ )

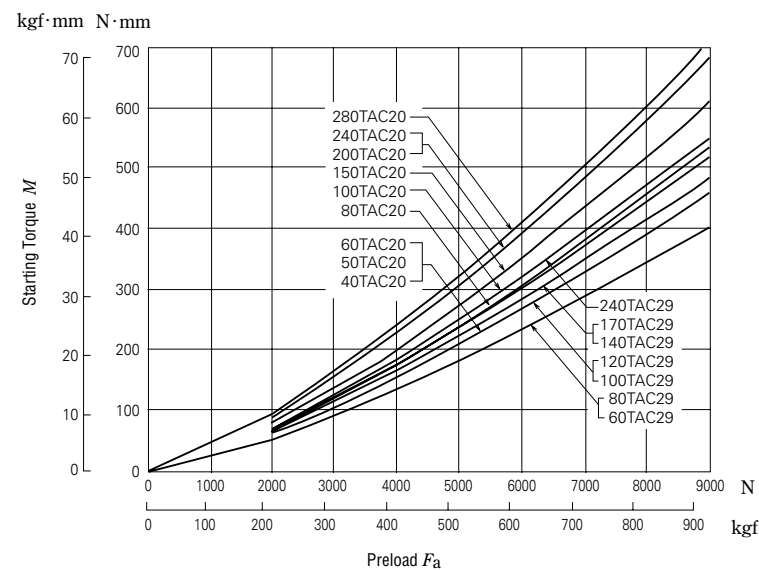

Fig. 15.12 Preload and Starting Torque of Double-Direction Angular Contact Thrust Ball Bearings

15.5 Coefficients of Dynamic Friction and Other Bearing Data

(1) Bearing Types and Their Coefficients of Dynamic Friction  $\mu$

$$\mu = \frac{M}{P \cdot \frac{d}{2}}$$

Table 15.5 Coefficients of Dynamic Friction

Bearing Types	Approximate values of $\mu$
Deep Groove Ball Bearings	0.0013
Angular Contact Ball Bearings	0.0015
Self-Aligning Ball Bearings	0.0010
Thrust Ball Bearings	0.0011
Cylindrical Roller Bearings	0.0010
Tapered Roller Bearings	0.0022
Spherical Roller Bearings	0.0028
Needle Roller Bearings with Cages	0.0015
Full Complement Needle Roller Bearings	0.0025
Spherical Thrust Roller Bearings	0.0028

(3) Radial Internal Clearance  $\Delta_r$  and Fatigue Life  $L$  (Fig. 15.13)

For the radial internal clearance  $\Delta_r$  and the function  $f(\epsilon)$  of the load factor, the following equations are valid:

For Deep Groove Ball Bearings

$$f(\epsilon) = \frac{\Delta_r \cdot D_w^{\frac{1}{3}}}{0.00044 \left(\frac{F_r}{Z}\right)^{\frac{2}{3}}} \dots\dots\dots (N)$$

$$f(\epsilon) = \frac{\Delta_r \cdot D_w^{\frac{1}{3}}}{0.002 \left(\frac{F_r}{Z}\right)^{\frac{2}{3}}} \dots\dots\dots \{kgf\}$$

For Cylindrical Roller Bearings

$$f(\epsilon) = \frac{\Delta_r \cdot L_{we}^{0.8}}{0.000077 \left(\frac{F_r}{Z}\right)^{0.9}} \dots\dots\dots (N)$$

$$f(\epsilon) = \frac{\Delta_r \cdot L_{we}^{0.8}}{0.0006 \left(\frac{F_r}{Z}\right)^{0.9}} \dots\dots\dots \{kgf\}$$

The relation between the load factor  $\epsilon$  and  $f(\epsilon)$  and  $L_{\epsilon}/L$ , when the radial internal clearance is  $\Delta_r$  is as shown in Table 15.7.

From the above equations, first obtain  $f(\epsilon)$  and then  $\epsilon$  and  $L_{\epsilon}/L$  can be obtained.

Table 15.7  $\epsilon$  and  $f(\epsilon)$ ,  $L_{\epsilon}/L$

$\epsilon$	Deep Groove Ball Bearings		Cylindrical Roller Bearings	
	$f(\epsilon)$	$\frac{L_{\epsilon}}{L}$	$f(\epsilon)$	$\frac{L_{\epsilon}}{L}$
0.1	33.713	0.294	51.315	0.220
0.2	10.221	0.546	14.500	0.469
0.3	4.045	0.737	5.539	0.691
0.4	1.408	0.889	1.887	0.870
0.5	0	1.0	0	1.0
0.6	-0.859	1.069	-1.133	1.075
0.7	-1.438	1.098	-1.897	1.096
0.8	-1.862	1.094	-2.455	1.065
0.9	-2.195	1.041	-2.929	0.968
1.0	-2.489	0.948	-3.453	0.805
1.25	-3.207	0.605	-4.934	0.378
1.5	-3.877	0.371	-6.387	0.196
1.67	-4.283	0.276	-7.335	0.133
1.8	-4.596	0.221	-8.082	0.100
2.0	-5.052	0.159	-9.187	0.067
2.5	-6.114	0.078	-11.904	0.029
3	-7.092	0.043	-14.570	0.015
4	-8.874	0.017	-19.721	0.005
5	-10.489	0.008	-24.903	0.002
10	-17.148	0.001	-48.395	0.0002

(2) Circumferential Speeds of Rolling Elements about Their Centers and Bearing Center

Table 15.6 Circumferential Speeds of Rolling Elements about Their Centers and Bearing Center

Items	Rotating inner ring, fixed outer ring	Rotating outer ring, fixed inner ring
Ball rotating speed $n_a$ (rpm)	$-\left(\frac{D_{pw}}{D_w} - \frac{\cos^2 \alpha}{D_{pw}/D_w}\right) \frac{n_i}{2}$	$+\left(\frac{D_{pw}}{D_w} - \frac{\cos^2 \alpha}{D_{pw}/D_w}\right) \frac{n_e}{2}$
Circumferential speed around bearing ball's center $v_a$ (m/sec)	$-\frac{\pi \cdot D_w}{60 \times 10^3} \left(\frac{D_{pw}}{D_w} - \frac{\cos^2 \alpha}{D_{pw}/D_w}\right) \frac{n_i}{2}$	$+\frac{\pi \cdot D_w}{60 \times 10^3} \left(\frac{D_{pw}}{D_w} - \frac{\cos^2 \alpha}{D_{pw}/D_w}\right) \frac{n_e}{2}$
Revolving speed around bearing center $n_c$ (rpm)	$+\left(1 - \frac{\cos \alpha}{D_{pw}/D_w}\right) \frac{n_i}{2}$	$+\left(1 - \frac{\cos \alpha}{D_{pw}/D_w}\right) \frac{n_e}{2}$
Circumferential speed around bearing center $v_c$ (m/sec)	$-\frac{\pi \cdot D_{pw}}{60 \times 10^3} \left(1 - \frac{\cos \alpha}{D_{pw}/D_w}\right) \frac{n_i}{2}$	$+\frac{\pi \cdot D_{pw}}{60 \times 10^3} \left(1 - \frac{\cos \alpha}{D_{pw}/D_w}\right) \frac{n_e}{2}$

Remarks 1. + sign indicates CW rotation and - sign CCW  
 2. The revolving speed and circumferential speed of the rolling elements are the same as those of the cage.

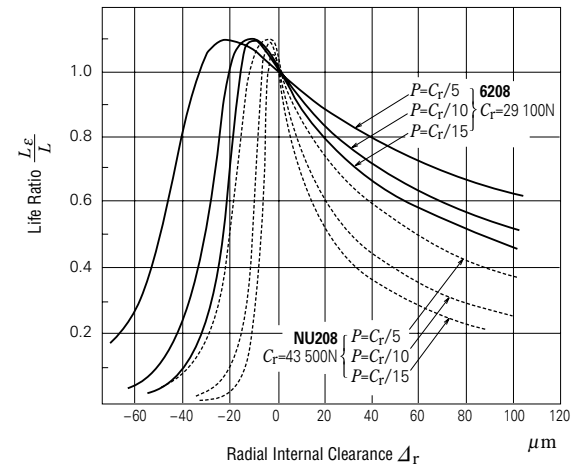

Fig. 15.13 Radial Internal Clearance and Life Ratio

15. 6 BRANDS AND PROPERTIES OF LUBRIVATING GREASES

Table 15. 8 Brands of Lubricating Greases

Brands	Thickeners	Base Oils
ADREX	Lithium	Mineral oil
APPOLOIL AUTOREX A	Lithium	Mineral oil
Arapen RB 300	Lithium/Calcium	Mineral oil
EA2 Grease	Urea	Poly- $\alpha$ -olefin oil
EA3 Grease	Urea	Poly- $\alpha$ -olefin oil
EA5 Grease	Urea	Poly- $\alpha$ -olefin oil
EA7 Grease	Urea	Poly- $\alpha$ -olefin oil
ENC Grease	Urea	Polyol ester oil + Mineral oil
ENS Grease	Urea	Polyol ester oil
ECZ	Lithium + Carbon black	Poly- $\alpha$ -olefin oil
ISOFLEX NBU 15	Barium Complex	Diester oil + Mineral oil
ISOFLEX SUPER LDS 18	Lithium	Diester oil
ISOFLEX TOPAS NB52	Barium Complex	Poly- $\alpha$ -olefin oil
Aero Shell Grease 7	Micro Gel	Diester oil
SH 33 L Grease	Lithium	Silicone oil
SH 44 M Grease	Lithium	Silicone oil
NS HI-LUBE	Lithium	Polyol ester oil + Diester oil
NSA	Lithium	Poly- $\alpha$ -olefin oil + Ester oil
NSC Grease	Lithium	Alkyldiphenyl ether oil + Polyol ester oil
NSK Clean Grease LG2	Lithium	Poly- $\alpha$ -olefin oil + Mineral oil
EMALUBE 8030	Urea	Mineral oil
MA8 Grease	Urea	Alkyldiphenyl ether oil + Poly- $\alpha$ -olefin oil
KRYTOX GPL-524	PTFE	Perfluoropolyether oil
KP1	PTFE	Perfluoropolyether oil
Cosmo Wide Grease WR No.3	Sodium Terephthalamate	Polyol ester oil + Mineral oil
G-40M	Lithium	Silicone oil
Shell Alvania EP Grease 2	Lithium	Mineral oil
Shell Alvania Grease S1	Lithium	Mineral oil
Shell Alvania Grease S2	Lithium	Mineral oil
Shell Alvania Grease S3	Lithium	Mineral oil
Shell Cassida Grease RLS 2	Aluminum Complex	Poly- $\alpha$ -olefin oil
SHELL SUNLIGHT Grease 2	Lithium	Mineral oil
WPH Grease	Urea	Poly- $\alpha$ -olefin oil
DEMNUM Grease L-200	PTFE	Perfluoropolyether oil

**Notes** (1) If grease will be used at the upper or lower limit sufficient of the temperature range or in a special environment such as vacuum, it is advisable to consult NSK.  
 (2) For short-term operation or when cooling is grease may be used at speeds exceeding the above limits provided the supply of grease is appropriate.

and Comparison of Properties

Dropping Point (°C)	Consistency	Working Temperature Range <sup>(1)</sup> (°C)	Pressure Resistance	Usable Limit Compared to Listed Limiting Speed <sup>(2)</sup> (%)
198	300	0 ~ +110	Good	70
198	280	-10 ~ +110	Fair	60
177	294	-10 ~ + 80	Fair	70
≥ 260	243	-40 ~ +150	Fair	100
≥ 260	230	-40 ~ +150	Fair	100
≥ 260	251	-40 ~ +160	Good	60
≥ 260	243	-40 ~ +160	Fair	100
≥ 260	262	-40 ~ +160	Fair	70
≥ 260	264	-40 ~ +160	Fair	100
≥ 260	243	-10 ~ +120	Fair	100
≥ 260	280	-30 ~ +120	Poor	100
195	280	-50 ~ +110	Poor	100
≥ 260	280	-40 ~ +130	Poor	90
≥ 260	288	-55 ~ +100	Poor	100
210	310	-60 ~ +120	Poor	60
210	260	-30 ~ +130	Poor	60
192	250	-40 ~ +130	Fair	100
201	311	-40 ~ +130	Fair	70
192	235	-30 ~ +140	Fair	70
201	199	-40 ~ +130	Poor	100
≥ 260	280	0 ~ +130	Good	60
≥ 260	283	-30 ~ +160	Fair	70
≥ 260	265	0 ~ +200	Fair	70
≥ 260	280	-30 ~ +200	Fair	60
≥ 230	227	-40 ~ +130	Poor	100
223	252	-30 ~ +130	Poor	60
187	276	0 ~ + 80	Good	60
182	323	-10 ~ +110	Fair	70
185	275	-10 ~ +110	Fair	70
185	242	-10 ~ +110	Fair	70
≥ 260	280	0 ~ +120	Fair	70
200	274	-10 ~ +110	Fair	70
259	240	-40 ~ +150	Fair	70
≥ 260	280	-30 ~ +200	Fair	60

(continued on next page)



Brands	Thickeners	Base Oils
NIGACE WR-S	Urea	Mixed oil
NIGLUB RSH	Sodium Complex	Polyalkylene Glycol oil
PYRONOC UNIVERSAL N6B	Urea	Mineral oil
PALMAX RBG	Lithium Complex	Mineral oil
Beacon 325	Lithium	Diester oil
MULTEMP PS No.2	Lithium	Mineral oil + Diester oil
MOLYKOTE FS-3451 Grease	PTFE	Fluorosilicone oil
UME Grease	Urea	Mineral oil
UMM Grease 2	Urea	Mineral oil
RAREMAX AF-1	Urea	Mineral oil

**Notes** (1) If grease will be used at the upper or lower limit sufficient of the temperature range or in a special environment such as vacuum, it is advisable to consult NSK.

(2) For short-term operation or when cooling is grease may be used at speeds exceeding the above limits provided the supply of grease is appropriate.

Dropping Point (°C)	Consistency	Working Temperature Range <sup>(1)</sup> (°C)	Pressure Resistance	Usable Limit Compared to Listed Limiting Speed <sup>(2)</sup> (%)
≥ 260	230	-30 ~ +150	Poor	70
≥ 260	270	-20 ~ +120	Fair	60
238	290	0 ~ +130	Fair	70
216	300	-10 ~ +130	Good	70
190	274	-50 ~ +110	Poor	100
190	275	-50 ~ +110	Poor	100
≥ 260	285	0 ~ +180	Fair	70
≥ 260	268	-10 ~ +130	Fair	70
≥ 260	267	-10 ~ +130	Fair	70
≥ 260	300	-10 ~ +130	Fair	70

# **BEARING TABLES**

## BEARING TABLE CONTENTS

	Page
<b>DEEP GROOVE BALL BEARINGS</b> .....	B4~ B45
Bore Dia.	
SINGLE-ROW DEEP GROOVE BALL BEARINGS	B8~ B25
MAXIMUM TYPE BALL BEARINGS	B26~ B27
MAGNETO BEARINGS	B28~ B29
EXTRA SMALL BALL BEARINGS AND	
MINIATURE BALL BEARINGS	B30~ B45
Metric Design	B34~ B41
Inch Design	B42~ B45
<b>ANGULAR CONTACT BALL BEARINGS</b> .....	B46~ B71
Bore Dia.	
SINGLE-ROW ANGULAR CONTACT BALL BEARINGS	B50~ B65
MATCHED ANGULAR CONTACT BALL BEARINGS	B50~ B65
DOUBLE-ROW ANGULAR CONTACT BALL BEARINGS	B66~ B67
FOUR-POINT CONTACT BALL BEARINGS	B68~ B71
<b>SELF-ALIGNING BALL BEARINGS</b> .....	B72~ B79
Bore Dia.	
SELF-ALIGNING BALL BEARINGS	B74~ B79
<b>CYLINDRICAL ROLLER BEARINGS</b> .....	B80~B105
Bore Dia.	
SINGLE-ROW CYLINDRICAL ROLLER BEARINGS	B84~ B99
L-SHAPED THRUST COLLARS FOR CYLINDRICAL ROLLER	
BEARINGS	B100~B101
DOUBLE-ROW CYLINDRICAL ROLLER BEARINGS	B102~B105
<b>TAPERED ROLLER BEARINGS</b> .....	B106~B177
Bore Dia.	
METRIC DESIGN TAPERED ROLLER BEARINGS	B112~B131
INCH DESIGN TAPERED ROLLER BEARINGS	B132~B167
DOUBLE-ROW TAPERED ROLLER BEARINGS	B168~B177
<b>SPHERICAL ROLLER BEARINGS</b> .....	B178~B201
Bore Dia.	
SPHERICAL ROLLER BEARINGS	B180~B201
<b>THRUST BEARINGS</b> .....	B202~B239
Bore Dia.	
SINGLE-DIRECTION THRUST BALL BEARINGS	B206~B213
DOUBLE-DIRECTION THRUST BALL BEARINGS	B214~B219
CYLINDRICAL ROLLER THRUST BEARINGS	B220~B223
SPHERICAL THRUST ROLLER BEARINGS	B224~B229
ANGULAR CONTACT THRUST BALL BEARINGS	B230~B239
Double-Direction Angular Contact Thrust Ball Bearings	B234~B237
Angular Contact Thrust Ball Bearings for Ball Screws	B238~B239
<b>Needle Roller Bearings</b> .....	B240~B275
Bore Dia.	
CAGE & NEEDLE ROLLER ASSEMBLIES	B248~B253
DRAWN CUP NEEDLE ROLLER BEARINGS	B254~B259
SOLID NEEDLE ROLLER BEARINGS	B260~B269
THRUST NEEDLE ROLLER BEARINGS	B270~B271
CAM FOLLOWERS	B272~B273
ROLLER FOLLOWERS	B274~B275
<b>BALL BEARING UNITS</b> .....	B276~B299
SET SCREW TYPE	
Pillow blocks cast housing	
UCP2	B282~B287
Flanged units cast housing	
UCF2	B288~B293
UCFL2	B294~B299
<b>PLUMMER BLOCKS</b> .....	B300~B321
Shaft Dia.	
STANDARD TYPE PLUMMER BLOCKS	B302~B307
LARGE PLUMMER BLOCKS	B308~B311
DUSTPROOF PLUMMER BLOCKS	B312~B313
STEPPED-SHAFT TYPE PLUMMER BLOCKS	B314~B321
<b>CYLINDRICAL ROLLER BEARINGS FOR SHEAVES</b> .....	B322~B329
Bore Dia.	
Open Type	B324~B327
Prelubricated Type	B328~B329
<b>ROLL-NECK BEARINGS</b> .....	B330~B339
FOUR-ROW TAPERED ROLLER BEARINGS	B334~B335
FOUR-ROW CYLINDRICAL ROLLER BEARINGS	B336~B339
<b>RAILWAY ROLLING STOCK BEARINGS</b> .....	B340~B341
<b>ROLLING ELEMENTS</b> .....	B342~B351
Basic Dia.	
STEEL BALLS FOR BALL BEARINGS	B344~B345
CYLINDRICAL ROLLERS FOR ROLLER BEARINGS	B346~B347
LONG CYLINDRICAL ROLLERS FOR ROLLER BEARINGS	B348~B349
NEEDLE ROLLERS FOR ROLLER BEARINGS	B350~B351
<b>ACCESSORIES FOR ROLLING BEARINGS</b> .....	B352~B375
Shaft Dia.	
ADAPTERS FOR ROLLING BEARINGS	B354~B361
WITHDRAWAL SLEEVES FOR ROLLING BEARINGS	B362~B367
NUTS FOR ROLLING BEARINGS	B368~B372
STOPPERS FOR ROLLING BEARINGS	B373
WASHERS FOR ROLLING BEARINGS	B374~B375

## DEEP GROOVE BALL BEARINGS

### SINGLE-ROW DEEP GROOVE BALL BEARINGS

Open Type, Shielded Type, Sealed Type      Bore Diameter 10-240mm .....Pages B8-B19

Open Type      Bore Diameter 260-800mm .....Pages B20-B25

**MAXIMUM TYPE BALL BEARINGS**      Bore Diameter 25-110mm .....Pages B26-B27

**MAGNETO BEARINGS**      Bore Diameter 4-20mm .....Pages B28-B29

Extra Small and Miniature Ball Bearings are described on Pages B30 to B45.

### DESIGN, TYPES, AND FEATURES

#### SINGLE-ROW DEEP GROOVE BALL BEARINGS

Single-Row Deep Groove Ball Bearings are classified into the types shown below.

The proper amount of good quality grease is packed in shielded and sealed ball bearings. A comparison of the features of each type is shown in Table 1.



**Table 1 Features of Sealed Ball Bearings**

Type	Shielded Type (ZZ Type)	Non-Contact Rubber Sealed Type (VV Type)	Contact Rubber Sealed Type (DDU Type)
Torque	Low	Low	Higher than ZZ, VV types due to contact seal
Speed capability	Good	Good	Limited by contact seals
Grease sealing effectiveness	Good	Better than ZZ type	A little better than VV type
Dust resistance	Good	Better than ZZ type (usable in moderately dusty environment)	Best (usable even in very dusty environment)
Water resistance	Not suitable	Not suitable	Good (usable even if fluid is splashed on bearing)
Operating temperature <sup>(1)</sup>	-10 to +110°C	-10 to +110°C	-10 to +100°C

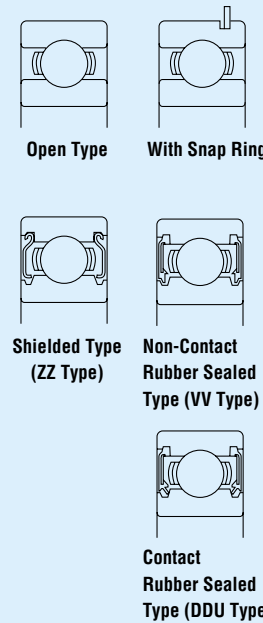

**Note** <sup>(1)</sup> The above temperature range applies to standard bearings. By using cold or heat resistant grease and changing the type of rubber, the operating temperature range can be extended. For such applications, please contact NSK.

For deep groove ball bearings, pressed cages are usually used. For big bearings, machined brass cages are used. (Refer to Table 2)

Machined cages are also used for high speed applications.

**Table 2 Standard Cages for Deep Groove Ball Bearings**

Series	Pressed Steel Cages	Machined Brass Cages
68	6800 ~ 6838	6840 ~ 68/800
69	6900 ~ 6936	6938 ~ 69/800
160	16001 ~ 16026	16028 ~ 16064
60	6000 ~ 6040	6044 ~ 60/670
62	6200 ~ 6240	6244 ~ 6272
63	6300 ~ 6332	6334 ~ 6356

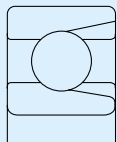

#### MAXIMUM TYPE BALL BEARINGS

Maximum Type Ball Bearings contain a larger number of balls than normal deep groove ball bearings because of filling slots in the inner and outer rings. Because of their filling slots, they are not suitable for applications with high axial loads.

BL2 and BL3 types of bearings have boundary dimensions equal to those of single-row deep groove ball bearings of Series 62 and 63 respectively. Besides the open type, ZZ type shielded bearings are also available.

When using these bearings, it is important for the filling slot in the outer ring to be outside of the loaded zone as much as possible.

Their cages are pressed steel.

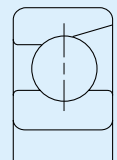

#### MAGNETO BEARINGS

The groove in the inner ring is a little shallower than that of deep groove ball bearings and one side of the outer ring is relieved. Consequently, the outer ring is separable, which makes it convenient for mounting.

Pressed cages are standard, but for high speed applications, machined synthetic resin cages are used.

#### PRECAUTIONS FOR USE OF DEEP GROOVE BALL BEARINGS

For deep groove ball bearings, if the bearing load is too small during operation, slippage occurs between the balls and raceways, which may result in smearing. The higher the weight of balls and cage, the higher this tendency becomes, especially for large bearings. If very small bearing loads are expected, please contact NSK for selection of an appropriate bearing.

#### TOLERANCES AND RUNNING ACCURACY

<b>SINGLE-ROW DEEP GROOVE BALL BEARINGS</b> .....	Table 8.2 (Pages A60~A63)
<b>MAXIMUM TYPE BALL BEARINGS</b> .....	Table 8.2 (Pages A60~A63)
<b>MAGNETO BEARINGS</b> .....	Table 8.5 (Pages A70~A71)

#### RECOMMENDED FITS

<b>SINGLE-ROW DEEP GROOVE BALL BEARINGS</b> .....	Table 9.2 (Page A84)
	Table 9.4 (Page A85)
<b>MAXIMUM TYPE BALL BEARINGS</b> .....	Table 9.2 (Page A84)
	Table 9.4 (Page A85)
<b>MAGNETO BEARINGS</b> .....	Table 9.2 (Page A84)
	Table 9.4 (Page A85)

#### INTERNAL CLEARANCES

<b>SINGLE-ROW DEEP GROOVE BALL BEARINGS</b> .....	Table 9.9 (Page A89)
<b>MAXIMUM TYPE BALL BEARINGS</b> .....	Table 9.9 (Page A89)
<b>MAGNETO BEARINGS</b> .....	Table 9.11 (Page A89)

#### LIMITING SPEEDS

The limiting speeds listed in the bearing tables should be adjusted depending on the bearing load conditions. Also, higher speeds are attainable by making changes in the lubrication method, cage design, etc. Refer to Page A37 for detailed information.

# SINGLE-ROW DEEP GROOVE BALL BEARINGS

Bore Diameter 10~22 mm

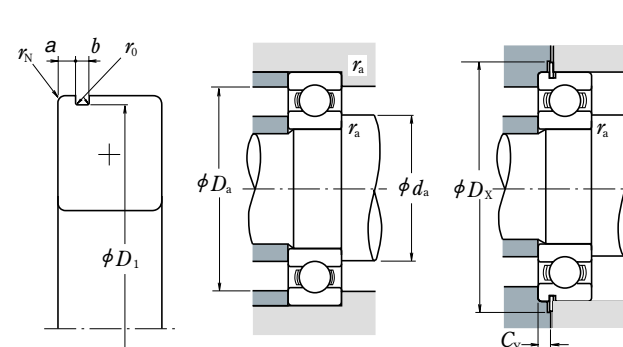
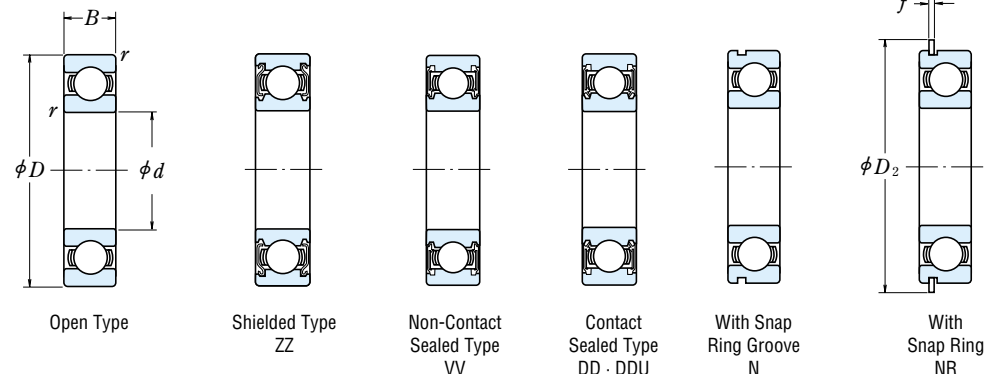

## Dynamic Equivalent Load

$$P = XF_r + YF_a$$

$\frac{f_0 F_a}{C_{0r}}$	e	$\frac{F_a}{F_r} \leq e$		$\frac{F_a}{F_r} > e$	
		X	Y	X	Y
0.172	0.19	1	0	0.56	2.30
0.345	0.22	1	0	0.56	1.99
0.689	0.26	1	0	0.56	1.71
1.03	0.28	1	0	0.56	1.55
1.38	0.30	1	0	0.56	1.45
2.07	0.34	1	0	0.56	1.31
3.45	0.38	1	0	0.56	1.15
5.17	0.42	1	0	0.56	1.04
6.89	0.44	1	0	0.56	1.00

## Static Equivalent Load

$$\frac{F_a}{F_r} > 0.8, P_0 = 0.6F_r + 0.5F_a$$

$$\frac{F_a}{F_r} \leq 0.8, P_0 = F_r$$

**NSK**

Boundary Dimensions (mm)	Basic Load Ratings (N)				Factor $f_0$	Limiting Speeds (rpm)			Bearing Numbers						
	$C_r$	$C_{0r}$	(kgf)			Grease		Oil	Open	Shielded	Sealed				
			$C_r$	$C_{0r}$		Open Z	Oil								
<b>10</b>	19	5	0.3	1 720	840	175	86	14.8	34 000	24 000	40 000	<b>6800</b>	<b>ZZ</b>	<b>VV</b>	<b>DD</b>
	22	6	0.3	2 700	1 270	275	129	14.0	32 000	22 000	38 000	<b>6900</b>	<b>ZZ</b>	<b>VV</b>	<b>DD</b>
	26	8	0.3	4 550	1 970	465	201	12.4	30 000	22 000	36 000	<b>6000</b>	<b>ZZ</b>	<b>VV</b>	<b>DDU</b>
	30	9	0.6	5 100	2 390	520	244	13.2	24 000	18 000	30 000	<b>6200</b>	<b>ZZ</b>	<b>VV</b>	<b>DDU</b>
	35	11	0.6	8 100	3 450	825	350	11.2	22 000	17 000	26 000	<b>6300</b>	<b>ZZ</b>	<b>VV</b>	<b>DDU</b>
<b>12</b>	21	5	0.3	1 920	1 040	195	106	15.3	32 000	20 000	38 000	<b>6801</b>	<b>ZZ</b>	<b>VV</b>	<b>DD</b>
	24	6	0.3	2 890	1 460	295	149	14.5	30 000	20 000	36 000	<b>6901</b>	<b>ZZ</b>	<b>VV</b>	<b>DD</b>
	28	7	0.3	5 100	2 370	520	241	13.0	28 000	—	32 000	<b>16001</b>	—	—	—
	28	8	0.3	5 100	2 370	520	241	13.0	28 000	18 000	32 000	<b>6001</b>	<b>ZZ</b>	<b>VV</b>	<b>DDU</b>
	32	10	0.6	6 800	3 050	695	310	12.3	22 000	17 000	28 000	<b>6201</b>	<b>ZZ</b>	<b>VV</b>	<b>DDU</b>
	37	12	1	9 700	4 200	990	425	11.1	20 000	16 000	24 000	<b>6301</b>	<b>ZZ</b>	<b>VV</b>	<b>DDU</b>
<b>15</b>	24	5	0.3	2 070	1 260	212	128	15.8	28 000	17 000	34 000	<b>6802</b>	<b>ZZ</b>	<b>VV</b>	<b>DD</b>
	28	7	0.3	4 350	2 260	440	230	14.3	26 000	17 000	30 000	<b>6902</b>	<b>ZZ</b>	<b>VV</b>	<b>DD</b>
	32	8	0.3	5 600	2 830	570	289	13.9	24 000	—	28 000	<b>16002</b>	—	—	—
	32	9	0.3	5 600	2 830	570	289	13.9	24 000	15 000	28 000	<b>6002</b>	<b>ZZ</b>	<b>VV</b>	<b>DDU</b>
	35	11	0.6	7 650	3 750	780	380	13.2	20 000	14 000	24 000	<b>6202</b>	<b>ZZ</b>	<b>VV</b>	<b>DDU</b>
	42	13	1	11 400	5 450	1 170	555	12.3	17 000	13 000	20 000	<b>6302</b>	<b>ZZ</b>	<b>VV</b>	<b>DDU</b>
<b>17</b>	26	5	0.3	2 630	1 570	268	160	15.7	26 000	15 000	30 000	<b>6803</b>	<b>ZZ</b>	<b>VV</b>	<b>DD</b>
	30	7	0.3	4 600	2 550	470	260	14.7	24 000	15 000	28 000	<b>6903</b>	<b>ZZ</b>	<b>VV</b>	<b>DDU</b>
	35	8	0.3	6 000	3 250	610	330	14.4	22 000	—	26 000	<b>16003</b>	—	—	—
	35	10	0.3	6 000	3 250	610	330	14.4	22 000	13 000	26 000	<b>6003</b>	<b>ZZ</b>	<b>VV</b>	<b>DDU</b>
	40	12	0.6	9 550	4 800	975	490	13.2	17 000	12 000	20 000	<b>6203</b>	<b>ZZ</b>	<b>VV</b>	<b>DDU</b>
	47	14	1	13 600	6 650	1 390	675	12.4	15 000	11 000	18 000	<b>6303</b>	<b>ZZ</b>	<b>VV</b>	<b>DDU</b>
<b>20</b>	32	7	0.3	4 000	2 470	410	252	15.5	22 000	13 000	26 000	<b>6804</b>	<b>ZZ</b>	<b>VV</b>	<b>DD</b>
	37	9	0.3	6 400	3 700	650	375	14.7	19 000	12 000	22 000	<b>6904</b>	<b>ZZ</b>	<b>VV</b>	<b>DDU</b>
	42	8	0.3	7 900	4 450	810	455	14.5	18 000	—	20 000	<b>16004</b>	—	—	—
	42	12	0.6	9 400	5 000	955	510	13.8	18 000	11 000	20 000	<b>6004</b>	<b>ZZ</b>	<b>VV</b>	<b>DDU</b>
	47	14	1	12 800	6 600	1 300	670	13.1	15 000	11 000	18 000	<b>6204</b>	<b>ZZ</b>	<b>VV</b>	<b>DDU</b>
	52	15	1.1	15 900	7 900	1 620	805	12.4	14 000	10 000	17 000	<b>6304</b>	<b>ZZ</b>	<b>VV</b>	<b>DDU</b>
<b>22</b>	44	12	0.6	9 400	5 050	960	515	14.0	17 000	11 000	20 000	<b>60/22</b>	<b>ZZ</b>	<b>VV</b>	<b>DDU</b>
	50	14	1	12 900	6 800	1 320	695	13.5	14 000	9 500	16 000	<b>62/22</b>	<b>ZZ</b>	<b>VV</b>	<b>DDU</b>
	56	16	1.1	18 400	9 250	1 870	940	12.4	13 000	9 500	16 000	<b>63/22</b>	<b>ZZ</b>	<b>VV</b>	<b>DDU</b>

**Notes** (1) For tolerances for the snap ring grooves and snap ring dimensions, refer to Pages A50 to A53.

(2) When heavy axial loads are applied, increase  $d_a$  and decrease  $D_a$  from the above values.

(3) Ring types N and NR applicable only to open-type bearings.

With Snap Ring Groove	With Snap Ring	Snap Ring Groove Dimensions (1) (mm)					Snap Ring (1) Dimensions (mm)		Abutment and Fillet Dimensions (mm)					Mass (kg) approx	
		a max	b min	$D_1$ max	$r_0$ max	$r_N$ min	$D_2$ max	f max	min	$d_a$ (2) max	$D_a$ (2) max	$r_a$ max	$D_x$ min		$C_Y$ max
—	—	—	—	—	—	—	—	—	12	12	17	0.3	—	—	0.005
<b>N</b> (3)	<b>NR</b> (3)	1.05	0.8	20.8	0.2	0.2	24.8	0.7	12	12.5	20	0.3	25.5	1.5	0.009
<b>N</b> (4)	<b>NR</b> (4)	1.35	0.87	24.5	0.2	0.3	28.7	0.84	12	13	24	0.3	29.4	1.9	0.018
<b>N</b>	<b>NR</b>	2.06	1.35	28.17	0.4	0.5	34.7	1.12	14	16	26	0.6	35.5	2.9	0.032
<b>N</b>	<b>NR</b>	2.06	1.35	33.17	0.4	0.5	39.7	1.12	14	16.5	31	0.6	40.5	2.9	0.052
—	—	—	—	—	—	—	—	—	14	14	19	0.3	—	—	0.006
<b>N</b>	<b>NR</b>	1.05	0.8	22.8	0.2	0.2	26.8	0.7	14	14.5	22	0.3	27.5	1.5	0.010
—	—	—	—	—	—	—	—	—	14	—	26	0.3	—	—	0.019
<b>N</b> (4)	<b>NR</b> (4)	1.35	0.87	26.5	0.2	0.3	30.7	0.84	14	15.5	26	0.3	31.4	1.9	0.022
<b>N</b>	<b>NR</b>	2.06	1.35	30.15	0.4	0.5	36.7	1.12	16	17	28	0.6	37.5	2.9	0.037
<b>N</b>	<b>NR</b>	2.06	1.35	34.77	0.4	0.5	41.3	1.12	17	18	32	1	42	2.9	0.060
—	—	—	—	—	—	—	—	—	17	17	22	0.3	—	—	0.007
<b>N</b>	<b>NR</b>	1.3	0.95	26.7	0.25	0.3	30.8	0.85	17	17	26	0.3	31.5	1.8	0.015
—	—	—	—	—	—	—	—	—	17	—	30	0.3	—	—	0.027
<b>N</b>	<b>NR</b>	2.06	1.35	30.15	0.4	0.3	36.7	1.12	17	19	30	0.3	37.5	2.9	0.031
<b>N</b>	<b>NR</b>	2.06	1.35	33.17	0.4	0.5	39.7	1.12	19	20.5	31	0.6	40.5	2.9	0.045
<b>N</b>	<b>NR</b>	2.06	1.35	39.75	0.4	0.5	46.3	1.12	20	22.5	37	1	47	2.9	0.083
—	—	—	—	—	—	—	—	—	19	19	24	0.3	—	—	0.007
<b>N</b>	<b>NR</b>	1.3	0.95	28.7	0.25	0.3	32.8	0.85	19	19.5	28	0.3	33.5	1.8	0.017
—	—	—	—	—	—	—	—	—	19	—	33	0.3	—	—	0.033
<b>N</b>	<b>NR</b>	2.06	1.35	33.17	0.4	0.3	39.7	1.12	19	21.5	33	0.3	40.5	2.9	0.041
<b>N</b>	<b>NR</b>	2.06	1.35	38.1	0.4	0.5	44.6	1.12	21	23.5	36	0.6	45.5	2.9	0.067
<b>N</b>	<b>NR</b>	2.46	1.35	44.6	0.4	0.5	52.7	1.12	22	25.5	42	1	53.5	3.3	0.113
<b>N</b>	<b>NR</b>	1.3	0.95	30.7	0.25	0.3	34.8	0.85	22	22	30	0.3	35.5	1.8	0.017
<b>N</b>	<b>NR</b>	1.7	0.95	35.7	0.25	0.3	39.8	0.85	22	22	35	0.3	40.5	2.3	0.037
—	—	—	—	—	—	—	—	—	22	—	40	0.3	—	—	0.048
<b>N</b>	<b>NR</b>	2.06	1.35	39.75	0.4	0.5	46.3	1.12	24	25.5	38	0.6	47	2.9	0.068
<b>N</b>	<b>NR</b>	2.46	1.35	44.6	0.4	0.5	52.7	1.12	25	26.5	42	1	53.5	3.3	0.107
<b>N</b>	<b>NR</b>	2.46	1.35	49.73	0.4	0.5	57.9	1.12	26.5	28	45.5	1	58.5	3.3	0.145
<b>N</b>	<b>NR</b>	2.06	1.35	41.75	0.4	0.5	48.3	1.12	26	26.5	40	0.6	49	2.9	0.074
<b>N</b>	<b>NR</b>	2.46	1.35	47.6	0.4	0.5	55.7	1.12	27	29.5	45	1	56.5	3.3	0.119
<b>N</b>	<b>NR</b>	2.46	1.35	53.6	0.4	0.5	61.7	1.12	28.5	30.5	49.5	1	62.5	3.3	0.179

**Notes** (4) Snap ring groove dimensions and snap ring dimensions are not conformed to ISO15.

**Remarks** 1. Diameter Series 7 (extra thin section bearings) are also available, please contact NSK.

2. When using bearings with rotating outer rings, contact NSK if they are sealed, shielded, or have snap rings.



# SINGLE-ROW DEEP GROOVE BALL BEARINGS

Bore Diameter 25~45 mm

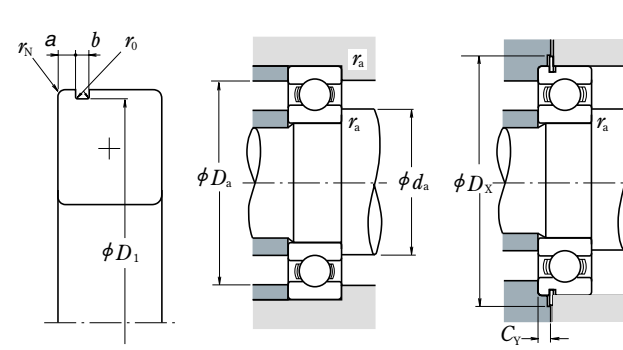
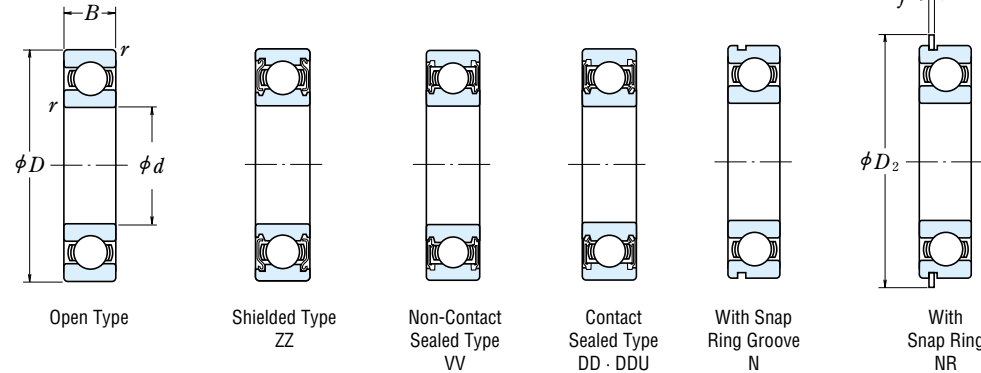

## Dynamic Equivalent Load

$$P = XF_r + YF_a$$

$\frac{f_0 F_a}{C_{0r}}$	e	$\frac{F_a}{F_r} \leq e$		$\frac{F_a}{F_r} > e$	
		X	Y	X	Y
0.172	0.19	1	0	0.56	2.30
0.345	0.22	1	0	0.56	1.99
0.689	0.26	1	0	0.56	1.71
1.03	0.28	1	0	0.56	1.55
1.38	0.30	1	0	0.56	1.45
2.07	0.34	1	0	0.56	1.31
3.45	0.38	1	0	0.56	1.15
5.17	0.42	1	0	0.56	1.04
6.89	0.44	1	0	0.56	1.00

## Static Equivalent Load

$$\frac{F_a}{F_r} > 0.8, P_0 = 0.6F_r + 0.5F_a$$

$$\frac{F_a}{F_r} \leq 0.8, P_0 = F_r$$

Boundary Dimensions (mm)	Basic Load Ratings (N)				Factor $f_0$	Limiting Speeds (rpm)			Bearing Numbers				
	$C_r$	$C_{0r}$	(kgf)			Grease		Oil	Open	Shielded	Sealed		
			$C_r$	$C_{0r}$		Open Z · ZZ V · VV	DU DDU						
25	37	7	0.3	4 500	3 150	16.1	18 000	10 000	22 000	6805	ZZ	VV	DD
	42	9	0.3	7 050	4 550	15.4	16 000	10 000	19 000	6905	ZZ	VV	DDU
	47	8	0.3	8 850	5 600	15.1	15 000	—	18 000	16005	—	—	—
	47	12	0.6	10 100	5 850	14.5	15 000	9 500	18 000	6005	ZZ	VV	DDU
	52	15	1	14 000	7 850	13.9	13 000	9 000	15 000	6205	ZZ	VV	DDU
	62	17	1.1	20 600	11 200	13.2	11 000	8 000	13 000	6305	ZZ	VV	DDU
28	52	12	0.6	12 500	7 400	14.5	14 000	8 500	16 000	60/28	ZZ	VV	DDU
	58	16	1	16 600	9 500	13.9	12 000	8 000	14 000	62/28	ZZ	VV	DDU
	68	18	1.1	26 700	14 000	12.4	10 000	7 500	13 000	63/28	ZZ	VV	DDU
	42	7	0.3	4 700	3 650	16.4	15 000	9 000	18 000	6806	ZZ	VV	DD
30	47	9	0.3	7 250	5 000	15.8	14 000	8 500	17 000	6906	ZZ	VV	DDU
	55	9	0.3	11 200	7 350	15.2	13 000	—	15 000	16006	—	—	—
	55	13	1	13 200	8 300	14.7	13 000	8 000	15 000	6006	ZZ	VV	DDU
32	62	16	1	19 500	11 300	13.8	11 000	7 500	13 000	6206	ZZ	VV	DDU
	72	19	1.1	26 700	15 000	13.3	9 500	6 700	12 000	6306	ZZ	VV	DDU
	58	13	1	15 100	9 150	14.5	12 000	7 500	14 000	60/32	ZZ	VV	DDU
35	65	17	1	20 700	11 600	13.6	10 000	7 100	12 000	62/32	ZZ	VV	DDU
	75	20	1.1	29 900	17 000	13.2	9 000	6 300	11 000	63/32	ZZ	VV	DDU
	47	7	0.3	4 900	4 100	16.7	14 000	7 500	16 000	6807	ZZ	VV	DD
40	55	10	0.6	10 600	7 250	15.5	12 000	7 500	15 000	6907	ZZ	VV	DDU
	62	9	0.3	11 700	8 200	15.6	11 000	—	13 000	16007	—	—	—
	62	14	1	16 000	10 300	14.8	11 000	6 700	13 000	6007	ZZ	VV	DDU
45	72	17	1.1	25 700	15 300	13.8	9 500	6 300	11 000	6207	ZZ	VV	DDU
	80	21	1.5	33 500	19 200	13.2	8 500	6 000	10 000	6307	ZZ	VV	DDU
	52	7	0.3	6 350	5 550	17.0	12 000	6 700	14 000	6808	ZZ	VV	DD
50	62	12	0.6	13 700	10 000	15.7	11 000	6 300	13 000	6908	ZZ	VV	DDU
	68	9	0.3	12 600	9 650	16.0	10 000	—	12 000	16008	—	—	—
	68	15	1	16 800	11 500	15.3	10 000	6 000	12 000	6008	ZZ	VV	DDU
55	80	18	1.1	29 100	17 900	14.0	8 500	5 600	10 000	6208	ZZ	VV	DDU
	90	23	1.5	40 500	24 000	13.2	7 500	5 300	9 000	6308	ZZ	VV	DDU
	58	7	0.3	6 600	6 150	17.2	11 000	6 000	13 000	6809	ZZ	VV	DD
60	68	12	0.6	14 100	10 900	15.9	9 500	5 600	12 000	6909	ZZ	VV	DDU
	75	10	0.6	14 900	11 400	15.9	9 000	—	11 000	16009	—	—	—
	75	16	1	20 900	15 200	15.3	9 000	5 300	11 000	6009	ZZ	VV	DDU
65	85	19	1.1	31 500	20 400	14.4	7 500	5 300	9 000	6209	ZZ	VV	DDU
	100	25	1.5	53 000	32 000	13.1	6 700	4 800	8 000	6309	ZZ	VV	DDU

With Snap Ring Groove	With Snap Ring	Snap Ring Groove Dimensions (1) (mm)					Snap Ring (1) Dimensions (mm)		Abutment and Fillet Dimensions (mm)					Mass (kg) approx	
		a max	b min	D1 max	r0 max	rN min	D2 max	f max	min	da(2) max	Da(2) max	ra max	Dx min		Cy max
N	NR	1.3	0.95	35.7	0.25	0.3	39.8	0.85	27	27	35	0.3	40.5	1.8	0.021
N	NR	1.7	0.95	40.7	0.25	0.3	44.8	0.85	27	28.5	40	0.3	45.5	2.3	0.042
—	—	—	—	—	—	—	—	—	27	—	45	0.3	—	—	0.059
N	NR	2.06	1.35	44.6	0.4	0.5	52.7	1.12	29	30	43	0.6	53.5	2.9	0.079
N	NR	2.46	1.35	49.73	0.4	0.5	57.9	1.12	30	32	47	1	58.5	3.3	0.129
N	NR	3.28	1.9	59.61	0.6	0.5	67.7	1.7	31.5	36	55.5	1	68.5	4.6	0.235
N	NR	2.06	1.35	49.73	0.4	0.5	57.9	1.12	32	34	48	0.6	58.5	2.9	0.096
N	NR	2.46	1.35	55.6	0.4	0.5	63.7	1.12	33	35.5	53	1	64.5	3.3	0.175
N	NR	3.28	1.9	64.82	0.6	0.5	74.6	1.7	34.5	38	61.5	1	76	4.6	0.287
N	NR	1.3	0.95	40.7	0.25	0.3	44.8	0.85	32	32	40	0.3	45.5	1.8	0.024
N	NR	1.7	0.95	45.7	0.25	0.3	49.8	0.85	32	34	45	0.3	50.5	2.3	0.052
—	—	—	—	—	—	—	—	—	32	—	53	0.3	—	—	0.087
N	NR	2.08	1.35	52.6	0.4	0.5	60.7	1.12	35	36.5	50	1	61.5	2.9	0.116
N	NR	3.28	1.9	59.61	0.6	0.5	67.7	1.7	35	38.5	57	1	68.5	4.6	0.199
N	NR	3.28	1.9	68.81	0.6	0.5	78.6	1.7	36.5	42.5	65.5	1	80	4.6	0.345
N	NR	2.08	1.35	55.6	0.4	0.5	63.7	1.12	37	38.5	53	1	64.5	2.9	0.122
N	NR	3.28	1.9	62.6	0.6	0.5	70.7	1.7	37	40	60	1	71.5	4.6	0.225
N	NR	3.28	1.9	71.83	0.6	0.5	81.6	1.7	38.5	44.5	68.5	1	83	4.6	0.389
N	NR	1.3	0.95	45.7	0.25	0.3	49.8	0.85	37	37	45	0.3	50.5	1.8	0.027
N	NR	1.7	0.95	53.7	0.25	0.5	57.8	0.85	39	39	51	0.6	58.5	2.3	0.075
—	—	—	—	—	—	—	—	—	37	—	60	0.3	—	—	0.107
N	NR	2.08	1.9	59.61	0.6	0.5	67.7	1.7	40	41.5	57	1	68.5	3.4	0.151
N	NR	3.28	1.9	68.81	0.6	0.5	78.6	1.7	41.5	44.5	65.5	1	80	4.6	0.284
N	NR	3.28	1.9	76.81	0.6	0.5	86.6	1.7	43	47	72	1.5	88	4.6	0.464
N	NR	1.3	0.95	50.7	0.25	0.3	54.8	0.85	42	42	50	0.3	55.5	1.8	0.031
N	NR	1.7	0.95	60.7	0.25	0.5	64.8	0.85	44	46	58	0.6	65.5	2.3	0.112
—	—	—	—	—	—	—	—	—	42	—	66	0.3	—	—	0.13
N	NR	2.49	1.9	64.82	0.6	0.5	74.6	1.7	45	47.5	63	1	76	3.8	0.19
N	NR	3.28	1.9	76.81	0.6	0.5	86.6	1.7	46.5	50.5	73.5	1	88	4.6	0.366
N	NR	3.28	2.7	86.79	0.6	0.5	96.5	2.46	48	53	82	1.5	98	5.4	0.636
N	NR	1.3	0.95	56.7	0.25	0.3	60.8	0.85	47	47.5	56	0.3	61.5	1.8	0.038
N	NR	1.7	0.95	66.7	0.25	0.5	70.8	0.85	49	50	64	0.6	72	2.3	0.126
—	—	—	—	—	—	—	—	—	49	—	71	0.6	—	—	0.167
N	NR	2.49	1.9	71.83	0.6	0.5	81.6	1.7	50	53.5	70	1	83	3.8	0.241
N	NR	3.28	1.9	81.81	0.6	0.5	91.6	1.7	51.5	55.5	78.5	1	93	4.6	0.42
N	NR	3.28	2.7	96.8	0.6	0.5	106.5	2.46	53	61.5	92	1.5	108	5.4	0.829

Notes (1) For tolerances for the snap ring grooves and snap ring dimensions, refer to Pages A50 to A53.

(2) When heavy axial loads are applied, increase  $d_a$  and decrease  $D_a$  from the above values.

Remarks 1. Diameter Series 7 (extra thin section bearings) are also available, please contact NSK.

2. When using bearings with rotating outer rings, contact NSK if they are sealed, shielded, or have snap rings.

# SINGLE-ROW DEEP GROOVE BALL BEARINGS

Bore Diameter 50~75 mm

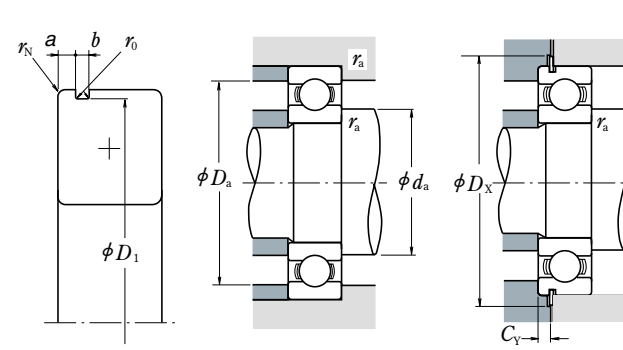
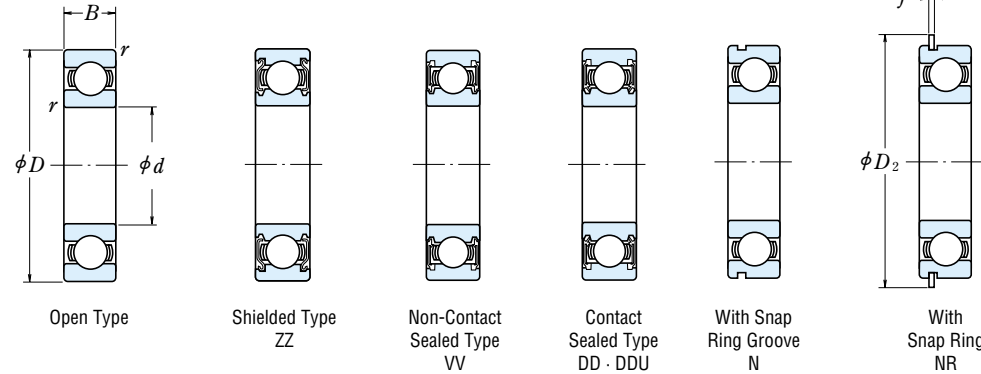

## Dynamic Equivalent Load

$$P = XF_r + YF_a$$

$\frac{f_0 F_a}{C_{0r}}$	$e$	$\frac{F_a}{F_r} \leq e$		$\frac{F_a}{F_r} > e$	
		X	Y	X	Y
0.172	0.19	1	0	0.56	2.30
0.345	0.22	1	0	0.56	1.99
0.689	0.26	1	0	0.56	1.71
1.03	0.28	1	0	0.56	1.55
1.38	0.30	1	0	0.56	1.45
2.07	0.34	1	0	0.56	1.31
3.45	0.38	1	0	0.56	1.15
5.17	0.42	1	0	0.56	1.04
6.89	0.44	1	0	0.56	1.00

## Static Equivalent Load

$$\frac{F_a}{F_r} > 0.8, P_0 = 0.6F_r + 0.5F_a$$

$$\frac{F_a}{F_r} \leq 0.8, P_0 = F_r$$

**NSK**

Boundary Dimensions (mm)	Basic Load Ratings (N)				Factor $f_0$	Limiting Speeds (rpm)			Bearing Numbers						
	$d$	$D$	$B$	$r_{min}$		Grease		Oil	Open	Shielded	Sealed				
						Open Z	ZZ	DD				DDU			
50	65	7	0.3	6 400	6 200	655	635	17.2	9 500	5 300	11 000	<b>6810</b>	<b>ZZ</b>	<b>VV</b>	<b>DDU</b>
	72	12	0.6	14 500	11 700	1 480	1 200	16.1	9 000	5 300	11 000	<b>6910</b>	<b>ZZ</b>	<b>VV</b>	<b>DDU</b>
	80	10	0.6	15 400	12 400	1 570	1 260	16.1	8 500	—	10 000	<b>16010</b>	—	—	—
	80	16	1	21 800	16 600	2 220	1 700	15.6	8 500	4 800	10 000	<b>6010</b>	<b>ZZ</b>	<b>VV</b>	<b>DDU</b>
	90	20	1.1	35 000	23 200	3 600	2 370	14.4	7 100	4 800	8 500	<b>6210</b>	<b>ZZ</b>	<b>VV</b>	<b>DDU</b>
	110	27	2	62 000	38 500	6 300	3 900	13.2	6 000	4 300	7 500	<b>6310</b>	<b>ZZ</b>	<b>VV</b>	<b>DDU</b>
55	72	9	0.3	8 800	8 500	900	865	17.0	8 500	4 800	10 000	<b>6811</b>	<b>ZZ</b>	<b>VV</b>	<b>DDU</b>
	80	13	1	16 000	13 300	1 630	1 350	16.2	8 000	4 500	9 500	<b>6911</b>	<b>ZZ</b>	<b>VV</b>	<b>DDU</b>
	90	11	0.6	19 400	16 300	1 980	1 660	16.2	7 500	—	9 000	<b>16011</b>	—	—	—
	90	18	1.1	28 300	21 200	2 880	2 170	15.3	7 500	4 500	9 000	<b>6011</b>	<b>ZZ</b>	<b>VV</b>	<b>DDU</b>
	100	21	1.5	43 500	29 300	4 450	2 980	14.3	6 300	4 300	7 500	<b>6211</b>	<b>ZZ</b>	<b>VV</b>	<b>DDU</b>
	120	29	2	71 500	44 500	7 300	4 550	13.1	5 600	4 000	6 700	<b>6311</b>	<b>ZZ</b>	<b>VV</b>	<b>DDU</b>
60	78	10	0.3	11 500	10 900	1 170	1 120	16.9	8 000	4 500	9 500	<b>6812</b>	<b>ZZ</b>	<b>VV</b>	<b>DD</b>
	85	13	1	19 400	16 300	1 980	1 660	16.2	7 500	4 300	9 000	<b>6912</b>	<b>ZZ</b>	<b>VV</b>	<b>DDU</b>
	95	11	0.6	20 000	17 500	2 040	1 780	16.3	7 100	—	8 500	<b>16012</b>	—	—	—
	95	18	1.1	29 500	23 200	3 000	2 370	15.6	7 100	4 000	8 500	<b>6012</b>	<b>ZZ</b>	<b>VV</b>	<b>DDU</b>
	110	22	1.5	52 500	36 000	5 350	3 700	14.3	5 600	3 800	7 100	<b>6212</b>	<b>ZZ</b>	<b>VV</b>	<b>DDU</b>
	130	31	2.1	82 000	52 000	8 350	5 300	13.1	5 300	3 600	6 300	<b>6312</b>	<b>ZZ</b>	<b>VV</b>	<b>DDU</b>
65	85	10	0.6	11 900	12 100	1 220	1 230	17.0	7 500	4 000	8 500	<b>6813</b>	<b>ZZ</b>	<b>VV</b>	<b>DD</b>
	90	13	1	17 400	16 100	1 770	1 640	16.6	7 100	4 000	8 500	<b>6913</b>	<b>ZZ</b>	<b>VV</b>	<b>DDU</b>
	100	11	0.6	20 500	18 700	2 090	1 910	16.5	6 700	—	8 000	<b>16013</b>	—	—	—
	100	18	1.1	30 500	25 200	3 100	2 570	15.8	6 700	4 000	8 000	<b>6013</b>	<b>ZZ</b>	<b>VV</b>	<b>DDU</b>
	120	23	1.5	57 500	40 000	5 850	4 100	14.4	5 300	3 600	6 300	<b>6213</b>	<b>ZZ</b>	<b>VV</b>	<b>DDU</b>
	140	33	2.1	92 500	60 000	9 450	6 100	13.2	4 800	3 400	6 000	<b>6313</b>	<b>ZZ</b>	<b>VV</b>	<b>DDU</b>
70	90	10	0.6	12 100	12 700	1 230	1 300	17.2	6 700	3 800	8 000	<b>6814</b>	<b>ZZ</b>	<b>VV</b>	<b>DD</b>
	100	16	1	23 700	21 200	2 420	2 160	16.3	6 300	3 600	7 500	<b>6914</b>	<b>ZZ</b>	<b>VV</b>	<b>DDU</b>
	110	13	0.6	26 800	23 600	2 730	2 410	16.3	6 000	—	7 100	<b>16014</b>	—	—	—
	110	20	1.1	38 000	31 000	3 900	3 150	15.6	6 000	3 600	7 100	<b>6014</b>	<b>ZZ</b>	<b>VV</b>	<b>DDU</b>
	125	24	1.5	62 000	44 000	6 350	4 500	14.5	5 000	3 400	6 300	<b>6214</b>	<b>ZZ</b>	<b>VV</b>	<b>DDU</b>
	150	35	2.1	104 000	68 000	10 600	6 950	13.2	4 500	3 200	5 300	<b>6314</b>	<b>ZZ</b>	<b>VV</b>	<b>DDU</b>
75	95	10	0.6	12 500	13 900	1 280	1 410	17.3	6 300	3 600	7 500	<b>6815</b>	<b>ZZ</b>	<b>VV</b>	<b>DDU</b>
	105	16	1	24 400	22 600	2 480	2 300	16.5	6 000	3 400	7 100	<b>6915</b>	<b>ZZ</b>	<b>VV</b>	<b>DDU</b>
	115	13	0.6	27 600	25 300	2 820	2 580	16.4	5 600	—	6 700	<b>16015</b>	—	—	—
	115	20	1.1	39 500	33 500	4 050	3 400	15.8	5 600	3 400	6 700	<b>6015</b>	<b>ZZ</b>	<b>VV</b>	<b>DDU</b>
	130	25	1.5	66 000	49 500	6 750	5 050	14.7	4 800	3 200	5 600	<b>6215</b>	<b>ZZ</b>	<b>VV</b>	<b>DDU</b>
	160	37	2.1	113 000	77 000	11 600	7 850	13.2	4 300	2 800	5 000	<b>6315</b>	<b>ZZ</b>	<b>VV</b>	<b>DDU</b>

With Snap Ring Groove	With Snap Ring	Snap Ring Groove Dimensions (1) (mm)					Snap Ring (1) Dimensions (mm)		Abutment and Fillet Dimensions (mm)					Mass (kg) approx	
		a max	b min	$D_1$ max	$r_0$ max	$r_N$ min	$D_2$ max	f max	min	$d_a$ (2) max	$D_a$ (2) max	$r_a$ max	$D_x$ min		$C_Y$ max
<b>N</b>	<b>NR</b>	1.3	0.95	63.7	0.25	0.3	67.8	0.85	52	52.5	63	0.3	68.5	1.8	0.050
<b>N</b>	<b>NR</b>	1.7	0.95	70.7	0.25	0.5	74.8	0.85	54	55	68	0.6	76	2.3	0.135
—	—	—	—	—	—	—	—	—	54	—	76	0.6	—	—	0.175
<b>N</b>	<b>NR</b>	2.49	1.9	76.81	0.6	0.5	86.6	1.7	55	58.5	75	1	88	3.8	0.261
<b>N</b>	<b>NR</b>	3.28	2.7	86.79	0.6	0.5	96.5	2.46	56.5	60	83.5	1	98	5.4	0.459
<b>N</b>	<b>NR</b>	3.28	2.7	106.81	0.6	0.5	116.6	2.46	59	68	101	2	118	5.4	1.06
<b>N</b>	<b>NR</b>	1.7	0.95	70.7	0.25	0.3	74.8	0.85	57	59	70	0.3	76	2.3	0.081
<b>N</b>	<b>NR</b>	2.1	1.3	77.9	0.4	0.5	84.4	1.12	60	61.5	75	1	86	2.9	0.189
—	—	—	—	—	—	—	—	—	59	—	86	0.6	—	—	0.257
<b>N</b>	<b>NR</b>	2.87	2.7	86.79	0.6	0.5	96.5	2.46	61.5	64	83.5	1	98	5	0.381
<b>N</b>	<b>NR</b>	3.28	2.7	96.8	0.6	0.5	106.5	2.46	63	66.5	92	1.5	108	5.4	0.619
<b>N</b>	<b>NR</b>	4.06	3.1	115.21	0.6	0.5	129.7	2.82	64	72.5	111	2	131.5	6.5	1.37
<b>N</b>	<b>NR</b>	1.7	1.3	76.2	0.4	0.3	82.7	1.12	62	64	76	0.3	84	2.5	0.103
<b>N</b>	<b>NR</b>	2.1	1.3	82.9	0.4	0.5	89.4	1.12	65	66	80	1	91	2.9	0.192
—	—	—	—	—	—	—	—	—	64	—	91	0.6	—	—	0.281
<b>N</b>	<b>NR</b>	2.87	2.7	91.82	0.6	0.5	101.6	2.46	66.5	69	88.5	1	103	5	0.412
<b>N</b>	<b>NR</b>	3.28	2.7	106.81	0.6	0.5	116.6	2.46	68	74.5	102	1.5	118	5.4	0.783
<b>N</b>	<b>NR</b>	4.06	3.1	125.22	0.6	0.5	139.7	2.82	71	79	119	2	141.5	6.5	1.72
<b>N</b>	<b>NR</b>	1.7	1.3	82.9	0.4	0.5	89.4	1.12	69	69	81	0.6	91	2.5	0.128
<b>N</b>	<b>NR</b>	2.1	1.3	87.9	0.4	0.5	94.4	1.12	70	71.5	85	1	96	2.9	0.218
—	—	—	—	—	—	—	—	—	69	—	96	0.6	—	—	0.30
<b>N</b>	<b>NR</b>	2.87	2.7	96.8	0.6	0.5	106.5	2.46	71.5	73	93.5	1	108	5	0.439
<b>N</b>	<b>NR</b>	4.06	3.1	115.21	0.6	0.5	129.7	2.82	73	80	112	1.5	131.5	6.5	1.0
<b>N</b>	<b>NR</b>	4.9	3.1	135.23	0.6	0.5	149.7	2.82	76	85.5	129	2	152	7.3	2.11
<b>N</b>	<b>NR</b>	1.7	1.3	87.9	0.4	0.5	94.4	1.12	74	74.5	86	0.6	96	2.5	0.134
<b>N</b>	<b>NR</b>	2.5	1.3	97.9	0.4	0.5	104.4	1.12	75	77.5	95	1	106	3.3	0.349
—	—	—	—	—	—	—	—	—	74	—	106	0.6	—	—	0.441
<b>N</b>	<b>NR</b>	2.87	2.7	106.81	0.6	0.5	116.6	2.46	76.5	80.5	103.5	1	118	5	0.608
<b>N</b>	<b>NR</b>	4.06	3.1	120.22	0.6	0.5	134.7	2.82	78	84	117	1.5	136.5	6.5	1.09
<b>N</b>	<b>NR</b>	4.9	3.1	145.24	0.6	0.5	159.7	2.82	81	92	139	2	162	7.3	2.57
<b>N</b>	<b>NR</b>	1.7	1.3	92.9	0.4	0.5	99.4	1.12	79	79.5	91	0.6	101	2.5	0.149
<b>N</b>	<b>NR</b>	2.5	1.3	102.6	0.4	0.5	110.7	1.12	80	82	100	1	112	3.3	0.364
—	—	—	—	—	—	—	—	—	79	—	111	0.6	—	—	0.463
<b>N</b>	<b>NR</b>	2.87	2.7	111.81	0.6	0.5	121.6	2.46	81.5	85.5	108.5	1	123	5	0.649
<b>N</b>	<b>NR</b>	4.06	3.1	125.22	0.6	0.5	139.7	2.82	83	90	122	1.5	141.5	6.5	1.19
<b>N</b>	<b>NR</b>	4.9	3.1	155.22	0.6	0.5	169.7	2.82	86	98.5	149	2	172	7.3	3.08

Notes (1) For tolerances for the snap ring grooves and snap ring dimensions, refer to Pages A50 to A53.

(2) When heavy axial loads are applied, increase  $d_a$  and decrease  $D_a$  from the above values.

Remarks 1. Diameter Series 7 (extra thin section bearings) are also available, please contact NSK.</

# SINGLE-ROW DEEP GROOVE BALL BEARINGS

Bore Diameter 80~105 mm

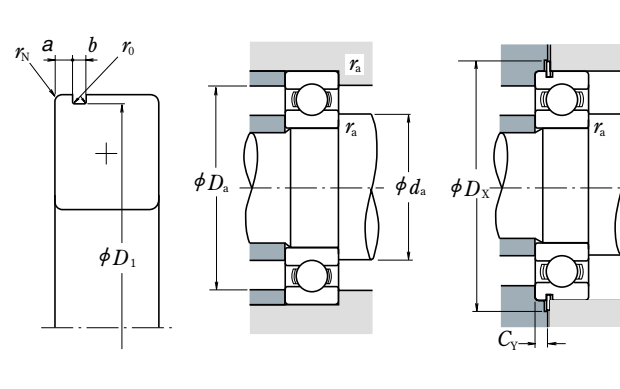
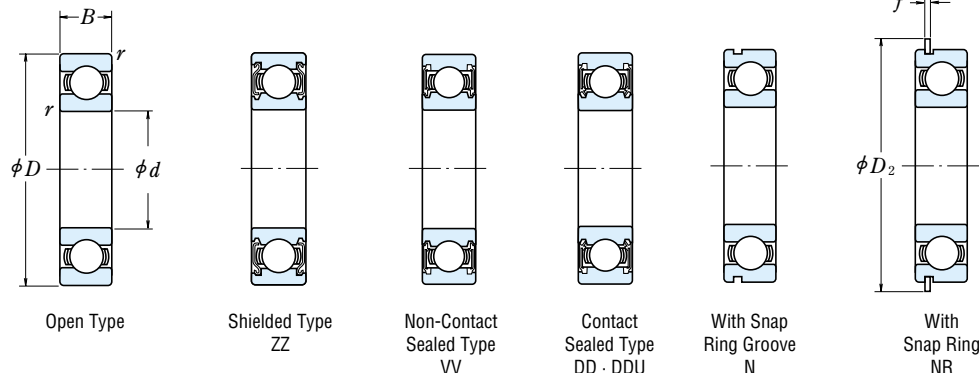

### Dynamic Equivalent Load

$$P = XF_r + YF_a$$

$\frac{f_0 F_a}{C_{0r}}$	$e$	$\frac{F_a}{F_r} \leq e$		$\frac{F_a}{F_r} > e$	
		X	Y	X	Y
0.172	0.19	1	0	0.56	2.30
0.345	0.22	1	0	0.56	1.99
0.689	0.26	1	0	0.56	1.71
1.03	0.28	1	0	0.56	1.55
1.38	0.30	1	0	0.56	1.45
2.07	0.34	1	0	0.56	1.31
3.45	0.38	1	0	0.56	1.15
5.17	0.42	1	0	0.56	1.04
6.89	0.44	1	0	0.56	1.00

### Static Equivalent Load

$$\frac{F_a}{F_r} > 0.8, P_0 = 0.6F_r + 0.5F_a$$

$$\frac{F_a}{F_r} \leq 0.8, P_0 = F_r$$

Boundary Dimensions (mm)	Basic Load Ratings (kgf)				Factor $f_0$	Limiting Speeds (rpm)			Bearing Numbers						
	(N)		(kgf)			Grease		Oil	Open	Shielded	Sealed				
	$C_r$	$C_{0r}$	$C_r$	$C_{0r}$		Open Z	DU DDU	Open Z							
<b>80</b>	100	10	0.6	12 700	14 500	1 290	1 470	17.4	6 000	3 400	7 100	<b>6816</b>	<b>ZZ</b>	<b>VV</b>	<b>DDU</b>
	110	16	1	25 000	24 000	2 540	2 450	16.6	5 600	3 200	6 700	<b>6916</b>	<b>ZZ</b>	<b>VV</b>	<b>DDU</b>
	125	14	0.6	32 000	29 600	3 250	3 000	16.4	5 300	—	6 300	<b>16016</b>	—	—	—
	125	22	1.1	47 500	40 000	4 850	4 050	15.6	5 300	3 200	6 300	<b>6016</b>	<b>ZZ</b>	<b>VV</b>	<b>DDU</b>
	140	26	2	72 500	53 000	7 400	5 400	14.6	4 500	3 000	5 300	<b>6216</b>	<b>ZZ</b>	<b>VV</b>	<b>DDU</b>
	170	39	2.1	123 000	86 500	12 500	8 850	13.3	4 000	2 800	4 800	<b>6316</b>	<b>ZZ</b>	<b>VV</b>	<b>DDU</b>
<b>85</b>	110	13	1	18 700	20 000	1 910	2 040	17.1	5 600	3 200	6 700	<b>6817</b>	<b>ZZ</b>	<b>VV</b>	<b>DDU</b>
	120	18	1.1	32 000	29 600	3 250	3 000	16.4	5 300	3 000	6 300	<b>6917</b>	<b>ZZ</b>	<b>VV</b>	<b>DDU</b>
	130	14	0.6	33 000	31 500	3 350	3 200	16.5	5 000	—	6 000	<b>16017</b>	—	—	—
	130	22	1.1	49 500	43 000	5 050	4 400	15.8	5 000	3 000	6 000	<b>6017</b>	<b>ZZ</b>	<b>VV</b>	<b>DDU</b>
	150	28	2	84 000	62 000	8 550	6 300	14.5	4 300	2 800	5 000	<b>6217</b>	<b>ZZ</b>	<b>VV</b>	<b>DDU</b>
	180	41	3	133 000	97 000	13 500	9 850	13.3	3 800	2 600	4 500	<b>6317</b>	<b>ZZ</b>	<b>VV</b>	<b>DDU</b>
<b>90</b>	115	13	1	19 000	21 000	1 940	2 140	17.2	5 300	3 000	6 300	<b>6818</b>	<b>ZZ</b>	<b>VV</b>	<b>DDU</b>
	125	18	1.1	33 000	31 500	3 350	3 200	16.5	5 000	2 800	6 000	<b>6918</b>	<b>ZZ</b>	<b>VV</b>	<b>DDU</b>
	140	16	1	41 500	39 500	4 250	4 000	16.3	4 800	—	5 600	<b>16018</b>	—	—	—
	140	24	1.5	58 000	50 000	5 950	5 050	15.6	4 800	2 800	5 600	<b>6018</b>	<b>ZZ</b>	<b>VV</b>	<b>DDU</b>
	160	30	2	96 000	71 500	9 800	7 300	14.5	4 000	2 600	4 800	<b>6218</b>	<b>ZZ</b>	<b>VV</b>	<b>DDU</b>
	190	43	3	143 000	107 000	14 500	11 000	13.3	3 600	2 400	4 300	<b>6318</b>	<b>ZZ</b>	<b>VV</b>	<b>DDU</b>
<b>95</b>	120	13	1	19 300	22 000	1 970	2 240	17.2	5 000	2 800	6 000	<b>6819</b>	<b>ZZ</b>	<b>VV</b>	<b>DD</b>
	130	18	1.1	33 500	33 500	3 450	3 400	16.6	4 800	2 800	5 600	<b>6919</b>	<b>ZZ</b>	<b>VV</b>	<b>DDU</b>
	145	16	1	43 000	42 000	4 350	4 250	16.4	4 500	—	5 300	<b>16019</b>	—	—	—
	145	24	1.5	60 500	54 000	6 150	5 500	15.8	4 500	2 600	5 300	<b>6019</b>	<b>ZZ</b>	<b>VV</b>	<b>DDU</b>
	170	32	2.1	109 000	82 000	11 100	8 350	14.4	3 800	2 600	4 500	<b>6219</b>	<b>ZZ</b>	<b>VV</b>	<b>DDU</b>
	200	45	3	153 000	119 000	15 600	12 100	13.3	3 000	2 400	3 600	<b>6319</b>	<b>ZZ</b>	<b>VV</b>	<b>DDU</b>
<b>100</b>	125	13	1	19 600	23 000	2 000	2 340	17.3	4 800	2 800	5 600	<b>6820</b>	<b>ZZ</b>	<b>VV</b>	<b>DD</b>
	140	20	1.1	43 000	42 000	4 350	4 250	16.4	4 500	2 600	5 300	<b>6920</b>	<b>ZZ</b>	<b>VV</b>	<b>DDU</b>
	150	16	1	42 500	42 000	4 300	4 300	16.5	4 300	—	5 300	<b>16020</b>	—	—	—
	150	24	1.5	60 000	54 000	6 150	5 550	15.9	4 300	2 600	5 300	<b>6020</b>	<b>ZZ</b>	<b>VV</b>	<b>DDU</b>
	180	34	2.1	122 000	93 000	12 500	9 500	14.4	3 600	2 400	4 300	<b>6220</b>	<b>ZZ</b>	<b>VV</b>	<b>DDU</b>
	215	47	3	173 000	141 000	17 700	14 400	13.2	2 800	2 200	3 400	<b>6320</b>	<b>ZZ</b>	<b>VV</b>	<b>DDU</b>
<b>105</b>	130	13	1	19 800	23 900	2 020	2 440	17.4	4 800	2 600	5 600	<b>6821</b>	<b>ZZ</b>	<b>VV</b>	<b>DDU</b>
	145	20	1.1	42 500	42 000	4 300	4 300	16.5	4 300	—	5 300	<b>6921</b>	<b>ZZ</b>	<b>VV</b>	—
	160	18	1	52 000	50 500	5 300	5 150	16.3	4 000	—	4 800	<b>16021</b>	—	—	—
	160	26	2	72 500	66 000	7 400	6 700	15.8	4 000	2 400	4 800	<b>6021</b>	<b>ZZ</b>	<b>VV</b>	<b>DDU</b>
	190	36	2.1	133 000	105 000	13 600	10 700	14.4	3 400	2 200	4 000	<b>6221</b>	<b>ZZ</b>	<b>VV</b>	<b>DDU</b>
	225	49	3	184 000	154 000	18 700	15 700	13.2	2 600	2 000	3 200	<b>6321</b>	<b>ZZ</b>	—	<b>DDU</b>

With Snap Ring Groove	With Snap Ring	Snap Ring Groove Dimensions (1) (mm)					Snap Ring (1) Dimensions (mm)		Abutment and Fillet Dimensions (mm)					Mass (kg) approx	
		a max	b min	D1 max	r0 max	rN min	D2 max	f max	min da(2)	max da(2)	max Da(2)	max ra	max Dx		max Cy
<b>N</b>	<b>NR</b>	1.7	1.3	97.9	0.4	0.5	104.4	1.12	84	84.5	96	0.6	106	2.5	0.151
<b>N</b>	<b>NR</b>	2.5	1.3	107.6	0.4	0.5	115.7	1.12	85	87.5	105	1	117	3.3	0.391
—	—	—	—	—	—	—	—	—	84	—	121	0.6	—	—	0.621
<b>N</b>	<b>NR</b>	2.87	3.1	120.22	0.6	0.5	134.7	2.82	86.5	91	118.5	1	136.5	5.3	0.872
<b>N</b>	<b>NR</b>	4.9	3.1	135.23	0.6	0.5	149.7	2.82	89	95.5	131	2	152	7.3	1.42
<b>N</b>	<b>NR</b>	5.69	3.5	163.65	0.6	0.5	182.9	3.1	91	104.5	159	2	185	8.4	3.67
<b>N</b>	<b>NR</b>	2.1	1.3	107.6	0.4	0.5	115.7	1.12	90	90.5	105	1	117	2.9	0.263
<b>N</b>	<b>NR</b>	3.3	1.3	117.6	0.4	0.5	125.7	1.12	91.5	94.5	113.5	1	127	4.1	0.55
—	—	—	—	—	—	—	—	—	89	—	126	0.6	—	—	0.652
<b>N</b>	<b>NR</b>	2.87	3.1	125.22	0.6	0.5	139.7	2.82	91.5	96	123.5	1	141.5	5.3	0.918
<b>N</b>	<b>NR</b>	4.9	3.1	145.24	0.6	0.5	159.7	2.82	94	102	141	2	162	7.3	1.76
<b>N</b>	<b>NR</b>	5.69	3.5	173.66	0.6	0.5	192.9	3.1	98	110.5	167	2.5	195	8.4	4.28
<b>N</b>	<b>NR</b>	2.1	1.3	112.6	0.4	0.5	120.7	1.12	95	95.5	110	1	122	2.9	0.276
<b>N</b>	<b>NR</b>	3.3	1.3	122.6	0.4	0.5	130.7	1.12	96.5	98.5	118.5	1	132	4.1	0.585
—	—	—	—	—	—	—	—	—	95	—	135	1	—	—	0.873
<b>N</b>	<b>NR</b>	3.71	3.1	135.23	0.6	0.5	149.7	2.82	98	103	132	1.5	152	6.1	1.19
<b>N</b>	<b>NR</b>	4.9	3.1	155.22	0.6	0.5	169.7	2.82	99	107.5	151	2	172	7.3	2.18
<b>N</b>	<b>NR</b>	5.69	3.5	183.64	0.6	0.5	202.9	3.1	103	117	177	2.5	205	8.4	4.98
<b>N</b>	<b>NR</b>	2.1	1.3	117.6	0.4	0.5	125.7	1.12	100	101.5	115	1	127	2.9	0.297
<b>N</b>	<b>NR</b>	3.3	1.3	127.6	0.4	0.5	135.7	1.12	101.5	103.5	123.5	1	137	4.1	0.601
—	—	—	—	—	—	—	—	—	100	—	140	1	—	—	0.904
<b>N</b>	<b>NR</b>	3.71	3.1	140.23	0.6	0.5	154.7	2.82	103	108.5	137	1.5	157	6.1	1.23
<b>N</b>	<b>NR</b>	5.69	3.5	163.65	0.6	0.5	182.9	3.1	106	114	159	2	185	8.4	2.64
<b>N</b>	<b>NR</b>	5.69	3.5	193.65	0.6	0.5	212.9	3.1	108	123.5	187	2.5	215	8.4	5.76
<b>N</b>	<b>NR</b>	2.1	1.3	122.6	0.4	0.5	130.7	1.12	105	105.5	120	1	132	2.9	0.31
<b>N</b>	<b>NR</b>	3.3	1.9	137.6	0.6	0.5	145.7	1.7	106.5	111	133.5	1	147	4.7	0.828
—	—	—	—	—	—	—	—	—	105	—	145	1	—	—	0.945
<b>N</b>	<b>NR</b>	3.71	3.1	145.24	0.6	0.5	159.7	2.82	108	112.5	142	1.5	162	6.1	1.29
<b>N</b>	<b>NR</b>	5.69	3.5	173.66	0.6	0.5	192.9	3.1	111	121.5	169	2	195	8.4	3.17
—	—	—	—	—	—	—	—	—	113	133	202	2.5	—	—	7.04
<b>N</b>	<b>NR</b>	2.1	1.3	127.6	0.4	0.5	135.7	1.12	110	110.5	125	1	137	2.9	0.324
<b>N</b>	<b>NR</b>	3.3	1.9	142.6	0.6	0.5	150.7	1.7	111.5	116	138.5	1	152	4.7	0.856
—	—	—	—	—	—	—	—	—	110	—	155	1	—	—	1.24
<b>N</b>	<b>NR</b>	3.71	3.1	155.22	0.6	0.5	169.7	2.82	114	120	151	2	172	6.1	1.58
<b>N</b>	<b>NR</b>	5.69	3.5	183.64	0.6	0.5	202.9	3.1	116	127.5	179	2	205	8.4	3.79
—	—	—	—	—	—	—	—	—	118	138	212	2.5	—	—	8.09

Notes (1) For tolerances for the snap ring grooves and snap ring dimensions, refer to Pages A50 to A53.

# SINGLE-ROW DEEP GROOVE BALL BEARINGS

Bore Diameter 110~160 mm

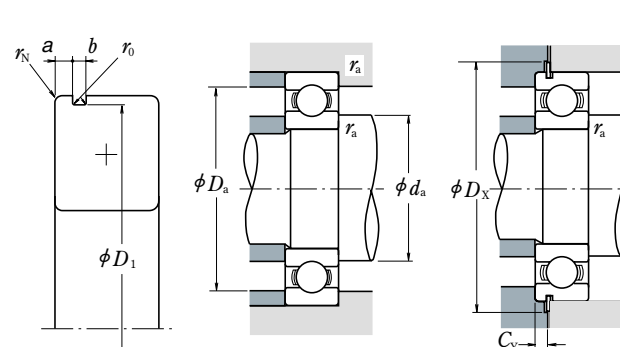
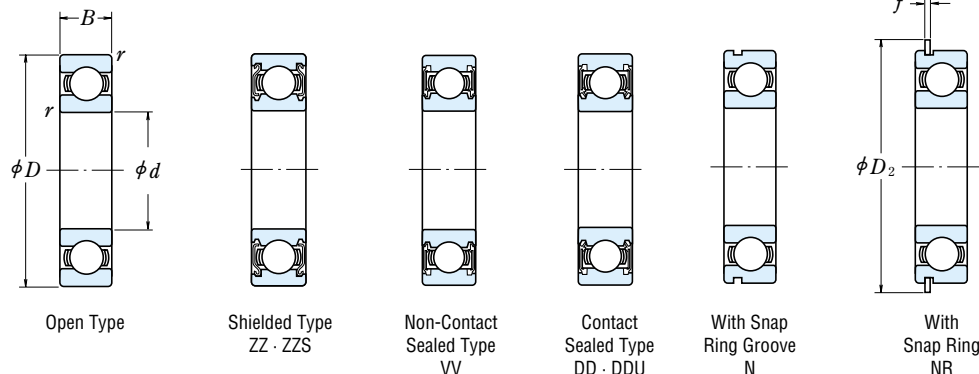

### Dynamic Equivalent Load

$$P = XF_r + YF_a$$

$\frac{f_0 F_a}{C_{0r}}$	$e$	$\frac{F_a}{F_r} \leq e$		$\frac{F_a}{F_r} > e$	
		X	Y	X	Y
0.172	0.19	1	0	0.56	2.30
0.345	0.22	1	0	0.56	1.99
0.689	0.26	1	0	0.56	1.71
1.03	0.28	1	0	0.56	1.55
1.38	0.30	1	0	0.56	1.45
2.07	0.34	1	0	0.56	1.31
3.45	0.38	1	0	0.56	1.15
5.17	0.42	1	0	0.56	1.04
6.89	0.44	1	0	0.56	1.00

### Static Equivalent Load

$$\frac{F_a}{F_r} > 0.8, P_0 = 0.6F_r + 0.5F_a$$

$$\frac{F_a}{F_r} \leq 0.8, P_0 = F_r$$

Boundary Dimensions (mm)	Basic Load Ratings (kgf)				Factor $f_0$	Limiting Speeds (rpm)			Bearing Numbers						
	(N)		(kgf)			Grease		Oil							
	$C_r$	$C_{0r}$	$C_r$	$C_{0r}$		Open Z	DU DDU	Open Z	Open	Shielded	Sealed				
<b>110</b>	140	16	1	28 100	32 500	2 860	3 350	17.1	4 300	2 400	5 300	<b>6822</b>	<b>ZZ</b>	<b>VV</b>	<b>DDU</b>
	150	20	1.1	43 500	44 500	4 450	4 550	16.6	4 300	2 400	5 000	<b>6922</b>	<b>ZZ</b>	<b>VV</b>	<b>DDU</b>
	170	19	1	57 500	56 500	5 850	5 800	16.3	3 800	—	4 500	<b>16022</b>	—	—	—
	170	28	2	85 000	73 000	8 650	7 450	15.5	3 800	2 200	4 500	<b>6022</b>	<b>ZZ</b>	<b>VV</b>	<b>DDU</b>
	200	38	2.1	144 000	117 000	14 700	11 900	14.3	2 800	2 200	3 400	<b>6222</b>	<b>ZZ</b>	<b>VV</b>	<b>DDU</b>
	240	50	3	205 000	179 000	20 900	18 300	13.2	2 400	—	3 000	<b>6322</b>	<b>ZZ</b>	—	—
<b>120</b>	150	16	1	28 900	35 500	2 950	3 650	17.3	4 000	2 200	4 800	<b>6824</b>	<b>ZZ</b>	<b>VV</b>	<b>DD</b>
	165	22	1.1	53 000	54 000	5 400	5 500	16.5	3 800	—	4 500	<b>6924</b>	<b>ZZ</b>	—	—
	180	19	1	56 500	57 500	5 800	5 850	16.5	3 600	—	4 300	<b>16024</b>	—	—	—
	180	28	2	88 000	80 000	9 000	8 150	15.7	3 600	2 200	4 300	<b>6024</b>	<b>ZZ</b>	<b>VV</b>	<b>DDU</b>
	215	40	2.1	155 000	131 000	15 800	13 400	14.4	2 600	2 000	3 200	<b>6224</b>	<b>ZZ</b>	<b>VV</b>	<b>DDU</b>
	260	55	3	207 000	185 000	21 100	18 800	13.5	2 200	1 800	2 800	<b>6324</b>	<b>ZZS</b>	—	<b>DDU</b>
<b>130</b>	165	18	1.1	37 000	44 000	3 750	4 450	17.1	3 600	2 000	4 300	<b>6826</b>	<b>ZZS</b>	<b>VV</b>	<b>DD</b>
	180	24	1.5	65 000	67 500	6 650	6 850	16.5	3 400	—	4 000	<b>6926</b>	<b>ZZ</b>	—	—
	200	22	1.1	75 500	77 500	7 700	7 900	16.4	3 000	—	3 600	<b>16026</b>	—	—	—
	200	33	2	106 000	101 000	10 800	10 300	15.8	3 000	1 900	3 600	<b>6026</b>	<b>ZZ</b>	—	<b>DDU</b>
	230	40	3	167 000	146 000	17 000	14 900	14.5	2 400	—	3 000	<b>6226</b>	<b>ZZ</b>	—	—
	280	58	4	229 000	214 000	23 400	21 800	13.6	2 200	—	2 600	<b>6326</b>	<b>ZZS</b>	—	—
<b>140</b>	175	18	1.1	38 500	48 000	3 900	4 850	17.3	3 400	1 900	4 000	<b>6828</b>	<b>ZZ</b>	<b>VV</b>	<b>DDU</b>
	190	24	1.5	66 500	72 000	6 800	7 300	16.6	3 200	—	3 800	<b>6928</b>	<b>ZZS</b>	<b>VV</b>	—
	210	22	1.1	77 500	82 500	7 900	8 400	16.5	2 800	—	3 400	<b>16028</b>	—	—	—
	210	33	2	110 000	109 000	11 200	11 100	16.0	2 800	1 800	3 400	<b>6028</b>	<b>ZZ</b>	—	<b>DDU</b>
	250	42	3	166 000	150 000	17 000	15 300	14.9	2 200	1 700	2 800	<b>6228</b>	<b>ZZS</b>	—	<b>DDU</b>
	300	62	4	253 000	246 000	25 800	25 100	13.6	2 000	—	2 400	<b>6328</b>	<b>ZZS</b>	—	—
<b>150</b>	190	20	1.1	47 500	58 500	4 850	5 950	17.1	3 200	1 800	3 800	<b>6830</b>	<b>ZZ</b>	<b>VV</b>	<b>DDU</b>
	210	28	2	85 000	90 500	8 650	9 200	16.5	2 600	1 700	3 200	<b>6930</b>	<b>ZZS</b>	—	<b>DDU</b>
	225	24	1.1	84 000	91 000	8 550	9 250	16.6	2 600	—	3 000	<b>16030</b>	—	—	—
	225	35	2.1	126 000	126 000	12 800	12 800	15.9	2 600	1 700	3 000	<b>6030</b>	<b>ZZ</b>	<b>VV</b>	<b>DDU</b>
	270	45	3	176 000	168 000	18 000	17 100	15.1	2 000	—	2 600	<b>6230</b>	<b>ZZS</b>	—	—
	320	65	4	274 000	284 000	28 000	28 900	13.9	1 800	—	2 200	<b>6330</b>	<b>ZZS</b>	—	—
<b>160</b>	200	20	1.1	48 500	61 000	4 950	6 250	17.2	2 600	1 700	3 200	<b>6832</b>	<b>ZZS</b>	<b>VV</b>	<b>DDU</b>
	220	28	2	87 000	96 000	8 850	9 800	16.6	2 600	1 600	3 000	<b>6932</b>	<b>ZZS</b>	—	<b>DDU</b>
	240	25	1.5	99 000	108 000	10 100	11 000	16.5	2 400	—	2 800	<b>16032</b>	—	—	—
	240	38	2.1	137 000	135 000	13 900	13 800	15.9	2 400	1 600	2 800	<b>6032</b>	<b>ZZ</b>	—	<b>DDU</b>
	290	48	3	185 000	186 000	18 900	19 000	15.4	1 900	—	2 400	<b>6232</b>	<b>ZZS</b>	—	—
	340	68	4	278 000	287 000	28 300	29 200	13.9	1 700	—	2 000	<b>6332</b>	<b>ZZS</b>	—	—

With Snap Ring Groove	With Snap Ring	Snap Ring Groove Dimensions (1) (mm)					Snap Ring (1) Dimensions (mm)		Abutment and Fillet Dimensions (mm)					Mass (kg) approx	
		a max	b min	D <sub>1</sub> max	r <sub>0</sub> max	r <sub>N</sub> min	D <sub>2</sub> max	f max	d <sub>a</sub> (2) min	d <sub>a</sub> (2) max	D <sub>a</sub> (2) max	r <sub>a</sub> max	D <sub>x</sub> min		C <sub>y</sub> max
<b>N</b>	<b>NR</b>	2.5	1.9	137.6	0.6	0.5	145.7	1.7	115	117	135	1	147	3.9	0.497
<b>N</b>	<b>NR</b>	3.3	1.9	147.6	0.6	0.5	155.7	1.7	116.5	121	143.5	1	157	4.7	0.893
		—	—	—	—	—	—	—	115	—	165	1	—	—	1.51
<b>N</b>	<b>NR</b>	3.71	3.5	163.65	0.6	0.5	182.9	3.1	119	124.5	161	2	185	6.4	1.94
<b>N</b>	<b>NR</b>	5.69	3.5	193.65	0.6	0.5	212.9	3.1	121	134	189	2	215	8.4	4.45
		—	—	—	—	—	—	—	123	147	227	2.5	—	—	9.51
<b>N</b>	<b>NR</b>	2.5	1.9	147.6	0.6	0.5	155.7	1.7	125	127	145	1	157	3.9	0.537
<b>N</b>	<b>NR</b>	3.7	1.9	161.8	0.6	0.5	171.5	1.7	126.5	132	158.5	1	173	5.1	1.21
		—	—	—	—	—	—	—	125	—	175	1	—	—	1.6
<b>N</b>	<b>NR</b>	3.71	3.5	173.66	0.6	0.5	192.9	3.1	129	134.5	171	2	195	6.4	2.08
		—	—	—	—	—	—	—	131	146	204	2	—	—	5.29
		—	—	—	—	—	—	—	133	161	247	2.5	—	—	12.5
<b>N</b>	<b>NR</b>	3.3	1.9	161.8	0.6	0.5	171.5	1.7	136.5	138	158.5	1	173	4.7	0.758
<b>N</b>	<b>NR</b>	3.7	1.9	176.8	0.6	0.5	186.5	1.7	138	144	172	1.5	188	5.1	1.57
		—	—	—	—	—	—	—	136.5	—	193.5	1	—	—	2.4
<b>N</b>	<b>NR</b>	5.69	3.5	193.65	0.6	0.5	212.9	3.1	139	148.5	191	2	215	8.4	3.26
		—	—	—	—	—	—	—	143	157	217	2.5	—	—	5.96
		—	—	—	—	—	—	—	146	175	264	3	—	—	15.2
<b>N</b>	<b>NR</b>	3.3	1.9	171.8	0.6	0.5	181.5	1.7	146.5	148.5	168.5	1	183	4.7	0.832
<b>N</b>	<b>NR</b>	3.7	1.9	186.8	0.6	0.5	196.5	1.7	148	153.5	182	1.5	198	5.1	1.67
		—	—	—	—	—	—	—	146.5	—	203.5	1	—	—	2.84
		—	—	—	—	—	—	—	149	158.5	201	2	—	—	3.48
		—	—	—	—	—	—	—	153	171.5	237	2.5	—	—	7.68
		—	—	—	—	—	—	—	156	187	284	3	—	—	18.5
<b>N</b>	<b>NR</b>	3.3	1.9	186.8	0.6	0.5	196.5	1.7	156.5	160	183.5	1	198	4.7	1.15
		—	—	—	—	—	—	—	159	166	201	2	—	—	3.01
		—	—	—	—	—	—	—	156.5	—	218.5	1	—	—	3.62
		—	—	—	—	—	—	—	161	170	214	2	—	—	4.24
		—	—	—	—	—	—	—	163	186	257	2.5	—	—	10
		—	—	—	—	—	—	—	166	203	304	3	—	—	22.7
<b>N</b>	<b>NR</b>	3.3	1.9	196.8	0.6	0.5	206.5	1.7	166.5	170.5	193.5	1	208	4.7	1.23
		—	—	—	—	—	—	—	169	176	211	2	—	—	2.71
		—	—	—	—	—	—	—	168	—	232	1.5	—	—	4.2
		—	—	—	—	—	—	—	171	181.5	229	2	—	—	5.15
		—	—	—	—	—	—	—	173	202	277	2.5	—	—	12.8
		—	—	—	—	—	—	—	176	215.5	324	3	—	—	26.2

Notes (1) For tolerances for the snap ring grooves and snap ring dimensions, refer to Pages A50 to A53.

(2) When heavy axial loads are applied, increase  $d_a$  and decrease  $D_a$  from the above values.

Remarks When using bearings with rotating outer rings, contact NSK if they are sealed, shielded, or have snap rings.

Bore Diameter 170~240 mm

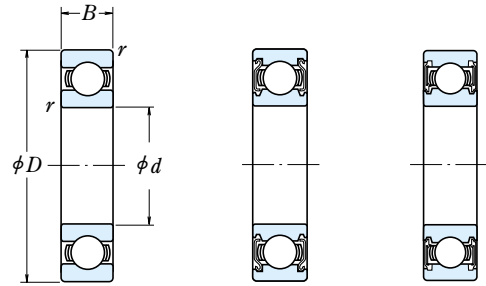

Open Type

Shielded Type  
ZZS

Non-Contact  
Sealed Type  
VV

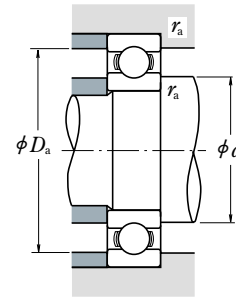

Dynamic Equivalent Load

$$P = X F_r + Y F_a$$

$\frac{f_0 F_a}{C_{0r}}$	$e$	$\frac{F_a}{F_r} \leq e$		$\frac{F_a}{F_r} > e$	
		X	Y	X	Y
0.172	0.19	1	0	0.56	2.30
0.345	0.22	1	0	0.56	1.99
0.689	0.26	1	0	0.56	1.71
1.03	0.28	1	0	0.56	1.55
1.38	0.30	1	0	0.56	1.45
2.07	0.34	1	0	0.56	1.31
3.45	0.38	1	0	0.56	1.15
5.17	0.42	1	0	0.56	1.04
6.89	0.44	1	0	0.56	1.00

Static Equivalent Load

$$\frac{F_a}{F_r} > 0.8, P_0 = 0.6 F_r + 0.5 F_a$$

$$\frac{F_a}{F_r} \leq 0.8, P_0 = F_r$$

Boundary Dimensions (mm)	Basic Load Ratings (N)				Factor $f_0$	Limiting Speeds (rpm)			Bearing Numbers						
	$d$	$D$	$B$	$r_{min}$		Grease		Oil	Open	Shielded	Sealed				
						$C_r$	$C_{0r}$	$C_r$				$C_{0r}$	Open Z		
170	215	22	1.1	60 000	75 000	6 100	7 650	17.1	2 600	1 600	3 000	<b>6834</b>	<b>ZZS</b>	<b>VV</b>	<b>DDU</b>
	230	28	2	86 000	97 000	8 750	9 850	16.7	2 400	—	2 800	<b>6934</b>	<b>ZZS</b>	—	—
	260	28	1.5	114 000	126 000	11 700	12 900	16.5	2 200	—	2 600	<b>16034</b>	—	—	—
	260	42	2.1	161 000	161 000	16 400	16 400	15.8	2 200	—	2 600	<b>6034</b>	<b>ZZS</b>	<b>VV</b>	—
	310	52	4	212 000	224 000	21 700	22 800	15.3	1 800	—	2 200	<b>6234</b>	<b>ZZS</b>	—	—
	360	72	4	325 000	355 000	33 500	36 000	13.6	1 600	—	2 000	<b>6334</b>	—	—	—
180	225	22	1.1	60 500	78 500	6 200	8 000	17.2	2 400	—	2 800	<b>6836</b>	—	<b>VV</b>	—
	250	33	2	119 000	128 000	12 100	13 100	16.4	2 200	—	2 600	<b>6936</b>	<b>ZZS</b>	—	—
	280	31	2	145 000	157 000	14 700	16 000	16.3	2 000	—	2 400	<b>16036</b>	—	—	—
	280	46	2.1	180 000	185 000	18 400	18 800	15.6	2 000	—	2 400	<b>6036</b>	<b>ZZS</b>	<b>VV</b>	—
	320	52	4	227 000	241 000	23 200	24 600	15.1	1 700	—	2 000	<b>6236</b>	<b>ZZS</b>	—	—
	380	75	4	355 000	405 000	36 000	41 500	13.9	1 500	—	1 800	<b>6336</b>	—	—	—
190	240	24	1.5	73 000	93 500	7 450	9 550	17.1	2 200	—	2 600	<b>6838</b>	—	<b>VV</b>	—
	260	33	2	113 000	127 000	11 500	13 000	16.6	2 200	—	2 600	<b>6938</b>	—	—	—
	290	31	2	149 000	168 000	15 200	17 100	16.4	2 000	—	2 400	<b>16038</b>	—	—	—
	290	46	2.1	188 000	201 000	19 200	20 500	15.8	2 000	—	2 400	<b>6038</b>	<b>ZZS</b>	—	—
	340	55	4	255 000	282 000	26 000	28 700	15.0	1 600	—	2 000	<b>6238</b>	<b>ZZS</b>	—	—
	400	78	5	355 000	415 000	36 000	42 500	14.1	1 400	—	1 700	<b>6338</b>	—	—	—
200	250	24	1.5	74 000	98 000	7 550	10 000	17.2	2 200	—	2 600	<b>6840</b>	—	—	—
	280	38	2.1	143 000	158 000	14 600	16 100	16.4	2 000	—	2 400	<b>6940</b>	<b>ZZS</b>	—	—
	310	34	2	161 000	180 000	16 400	18 300	16.4	1 900	—	2 200	<b>16040</b>	—	—	—
	310	51	2.1	207 000	226 000	21 100	23 000	15.6	1 900	—	2 200	<b>6040</b>	<b>ZZS</b>	—	—
	360	58	4	269 000	310 000	27 400	31 500	15.2	1 500	—	1 800	<b>6240</b>	<b>ZZS</b>	—	—
	420	80	5	380 000	445 000	38 500	45 500	13.8	1 300	—	1 600	<b>6340</b>	—	—	—
220	270	24	1.5	76 500	107 000	7 800	10 900	17.4	1 900	—	2 400	<b>6844</b>	<b>ZZS</b>	—	—
	300	38	2.1	146 000	169 000	14 900	17 300	16.6	1 800	—	2 200	<b>6944</b>	<b>ZZS</b>	—	—
	340	37	2.1	180 000	217 000	18 400	22 100	16.5	1 600	—	2 000	<b>16044</b>	—	—	—
	340	56	3	235 000	271 000	24 000	27 600	15.6	1 700	—	2 000	<b>6044</b>	<b>ZZS</b>	—	—
	400	65	4	310 000	375 000	31 500	38 500	15.1	1 300	—	1 600	<b>6244</b>	—	—	—
	460	88	5	410 000	520 000	42 000	53 000	14.3	1 200	—	1 500	<b>6344</b>	—	—	—
240	300	28	2	98 500	137 000	10 000	14 000	17.3	1 700	—	2 000	<b>6848</b>	—	—	—
	320	38	2.1	154 000	190 000	15 700	19 400	16.8	1 700	—	2 000	<b>6948</b>	<b>ZZS</b>	—	—
	360	37	2.1	196 000	243 000	19 900	24 700	16.5	1 500	—	1 900	<b>16048</b>	—	—	—
	360	56	3	244 000	296 000	24 900	30 000	15.9	1 500	—	1 900	<b>6048</b>	—	—	—
	440	72	4	340 000	430 000	34 500	44 000	15.2	1 200	—	1 500	<b>6248</b>	—	—	—
	500	95	5	470 000	625 000	48 000	63 500	14.2	1 100	—	1 300	<b>6348</b>	—	—	—

Note (1) When heavy axial loads are applied, increase  $d_a$  and decrease  $D_a$  from the above values.

Remarks When using bearings with rotating outer rings, contact NSK if they are sealed or shielded.

min	Abutment and Fillet Dimensions (mm)			Mass (kg) approx
	$d_a^{(1)}$	$D_a^{(1)}$	$r_a$	
176.5	182	208.5	1	1.86
179	186	221	2	3.34
178	—	252	1.5	5.71
181	194.5	249	2	6.89
186	215	294	3	15.8
186	—	344	3	36.6
186.5	192	218.5	1	1.98
189	198.5	241	2	4.16
189	—	271	2	7.5
191	208	269	2	8.88
196	223	304	3	15.9
196	—	364	3	43.1
198	202.5	232	1.5	2.53
199	—	251	2	5.18
199	—	281	2	7.78
201	218	279	2	9.39
206	236	324	3	22.3
210	—	380	4	49.7
208	—	242	1.5	2.67
211	222	269	2	7.28
209	—	301	2	10
211	231.5	299	2	12
216	252	344	3	26.7
220	—	400	4	55.3
228	233.5	262	1.5	2.9
231	242	289	2	7.88
231	—	329	2	13.1
233	254.5	327	2.5	18.6
236	—	384	3	37.4
240	—	440	4	73.9
249	—	291	2	4.48
251	262	309	2	8.49
251	—	349	2	13.9
253	—	347	2.5	19.9
256	—	424	3	50.5
260	—	480	4	94.4



Bore Diameter 260~360 mm

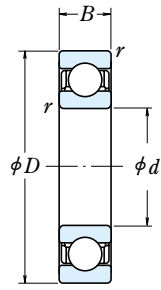

Open Type

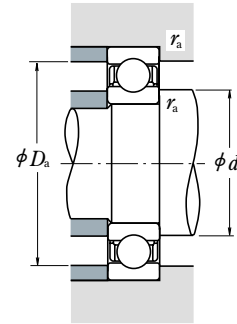

Dynamic Equivalent Load

$$P = XF_r + YF_a$$

$\frac{f_0 F_a}{C_{0r}}$	$e$	$\frac{F_a}{F_r} \leq e$		$\frac{F_a}{F_r} > e$	
		X	Y	X	Y
0.172	0.19	1	0	0.56	2.30
0.345	0.22	1	0	0.56	1.99
0.689	0.26	1	0	0.56	1.71
1.03	0.28	1	0	0.56	1.55
1.38	0.30	1	0	0.56	1.45
2.07	0.34	1	0	0.56	1.31
3.45	0.38	1	0	0.56	1.15
5.17	0.42	1	0	0.56	1.04
6.89	0.44	1	0	0.56	1.00

Static Equivalent Load

$$\frac{F_a}{F_r} > 0.8, P_0 = 0.6F_r + 0.5F_a$$

$$\frac{F_a}{F_r} \leq 0.8, P_0 = F_r$$

Boundary Dimensions (mm)				Basic Load Ratings				Factor	Limiting Speeds (rpm)		Bearing Numbers	
$d$	$D$	$B$	$r_{min}$	$C_r$ (N)	$C_{0r}$ (N)	$C_r$ (kgf)	$C_{0r}$ (kgf)		Grease	Oil		Open
260	320	28	2	101 000	148 000	10 300	15 100	17.4	1 600	1 900	6852	
	360	46	2.1	204 000	255 000	20 800	26 000	16.5	1 500	1 800	6952	
	400	44	3	237 000	310 000	24 100	31 500	16.4	1 400	1 700	16052	
280	400	65	4	291 000	375 000	29 700	38 500	15.8	1 400	1 700	6052	
	480	80	5	400 000	540 000	41 000	55 000	15.1	1 100	1 300	6252	
	540	102	6	505 000	710 000	51 500	72 500	14.6	1 000	1 200	6352	
300	350	33	2	133 000	191 000	13 600	19 500	17.3	1 500	1 700	6856	
	380	46	2.1	209 000	272 000	21 300	27 700	16.6	1 400	1 700	6956	
	420	44	3	243 000	330 000	24 700	33 500	16.5	1 300	1 600	16056	
320	420	65	4	300 000	410 000	31 000	41 500	16.0	1 300	1 600	6056	
	500	80	5	400 000	550 000	41 000	56 000	15.2	1 000	1 300	6256	
	580	108	6	570 000	840 000	58 000	86 000	14.5	900	1 100	6356	
340	380	38	2.1	166 000	233 000	17 000	23 800	17.1	1 300	1 600	6860	
	420	56	3	269 000	370 000	27 400	38 000	16.4	1 300	1 500	6960	
	460	50	4	285 000	405 000	29 000	41 000	16.4	1 200	1 400	16060	
360	460	74	4	355 000	500 000	36 500	51 000	15.8	1 200	1 400	6060	
	540	85	5	465 000	670 000	47 500	68 500	15.1	950	1 200	6260	
	380	400	38	2.1	168 000	244 000	17 200	24 900	17.2	1 300	1 500	6864
440		56	3	266 000	375 000	27 100	38 000	16.5	1 200	1 400	6964	
480		50	4	293 000	430 000	29 800	44 000	16.5	1 100	1 300	16064	
400	480	74	4	390 000	570 000	40 000	58 000	15.7	1 100	1 300	6064	
	580	92	5	530 000	805 000	54 500	82 500	15.0	850	1 100	6264	
	420	420	38	2.1	175 000	265 000	17 800	27 100	17.3	1 200	1 400	6868
460		56	3	273 000	400 000	27 800	40 500	16.6	1 100	1 300	6968	
520		82	5	440 000	660 000	45 000	67 500	15.6	1 000	1 200	6068	
440	620	92	6	530 000	820 000	54 000	83 500	15.3	800	1 000	6268	
	460	440	38	2.1	192 000	290 000	19 600	29 600	17.3	1 100	1 300	6872
		480	56	3	280 000	425 000	28 500	43 000	16.7	1 100	1 300	6972
540		82	5	460 000	720 000	47 000	73 500	15.7	950	1 200	6072	
480	650	95	6	555 000	905 000	57 000	92 000	15.4	750	950	6272	

Note (1) When heavy axial loads are applied, increase  $d_a$  and decrease  $D_a$  from the above values.

Abutment and Fillet Dimensions (mm)			Mass (kg)
$d_a^{(1)}$ min	$D_a^{(1)}$ max	$r_a$ max	
269	311	2	4.84
271	349	2	14
273	387	2.5	21.1
276	384	3	29.4
280	460	4	67
286	514	5	118
289	341	2	7.2
291	369	2	15.1
293	407	2.5	22.7
296	404	3	31.2
300	480	4	70.4
306	554	5	144
311	369	2	10.3
313	407	2.5	23.9
316	444	3	31.5
316	444	3	44.2
320	520	4	87.8
331	389	2	10.8
333	427	2.5	25.3
336	464	3	33.2
336	464	3	46.5
340	560	4	111
351	409	2	11.5
353	447	2.5	26.6
360	500	4	62.3
366	594	5	129
371	429	2	11.8
373	467	2.5	27.9
380	520	4	65.3
386	624	5	145



Bore Diameter 380~600 mm

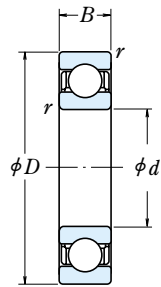

Open Type

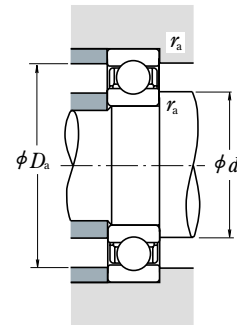

Dynamic Equivalent Load

$$P = XF_r + YF_a$$

$\frac{f_0 F_a}{C_{0r}}$	$e$	$\frac{F_a}{F_r} \leq e$		$\frac{F_a}{F_r} > e$	
		X	Y	X	Y
0.172	0.19	1	0	0.56	2.30
0.345	0.22	1	0	0.56	1.99
0.689	0.26	1	0	0.56	1.71
1.03	0.28	1	0	0.56	1.55
1.38	0.30	1	0	0.56	1.45
2.07	0.34	1	0	0.56	1.31
3.45	0.38	1	0	0.56	1.15
5.17	0.42	1	0	0.56	1.04
6.89	0.44	1	0	0.56	1.00

Static Equivalent Load

$$\frac{F_a}{F_r} > 0.8, P_0 = 0.6F_r + 0.5F_a$$

$$\frac{F_a}{F_r} \leq 0.8, P_0 = F_r$$

Boundary Dimensions (mm)				Basic Load Ratings				Factor	Limiting Speeds (rpm)		Bearing Numbers
$d$	$D$	$B$	$r_{min}$	$C_r$ (N)	$C_{0r}$ (N)	$C_r$ (kgf)	$C_{0r}$ (kgf)		Grease	Oil	
380	480	46	2.1	238 000	375 000	24 200	38 000	17.1	1 000	1 200	6876
	520	65	4	325 000	510 000	33 000	52 000	16.6	950	1 200	6976
	560	82	5	455 000	725 000	46 500	74 000	15.9	900	1 100	6076
400	500	46	2.1	241 000	390 000	24 600	40 000	17.2	950	1 200	6880
	540	65	4	335 000	540 000	34 000	55 000	16.7	900	1 100	6980
	600	90	5	510 000	825 000	52 000	84 000	15.7	850	1 000	6080
420	520	46	2.1	245 000	410 000	25 000	41 500	17.3	900	1 100	6884
	560	65	4	340 000	570 000	35 000	58 500	16.8	900	1 100	6984
	620	90	5	530 000	895 000	54 000	91 000	15.8	800	1 000	6084
440	540	46	2.1	248 000	425 000	25 300	43 500	17.4	900	1 100	6888
	600	74	4	395 000	680 000	40 500	69 000	16.6	800	1 000	6988
	650	94	6	550 000	965 000	56 000	98 500	16.0	750	900	6088
460	580	56	3	310 000	550 000	31 500	56 000	17.1	800	1 000	6892
	620	74	4	405 000	720 000	41 500	73 500	16.7	800	950	6992
	680	100	6	605 000	1 080 000	62 000	110 000	15.8	710	850	6092
480	600	56	3	315 000	575 000	32 000	58 500	17.2	800	950	6896
	650	78	5	450 000	815 000	45 500	83 000	16.6	750	900	6996
	700	100	6	605 000	1 090 000	61 500	111 000	15.9	710	850	6096
500	620	56	3	320 000	600 000	33 000	61 000	17.3	750	900	68/500
	670	78	5	460 000	865 000	47 000	88 000	16.7	710	850	69/500
	720	100	6	630 000	1 170 000	64 000	120 000	16.0	670	800	60/500
530	650	56	3	325 000	625 000	33 000	63 500	17.4	710	850	68/530
	710	82	5	455 000	870 000	46 500	88 500	16.8	670	800	69/530
	780	112	6	680 000	1 300 000	69 500	133 000	16.0	600	750	60/530
560	680	56	3	330 000	650 000	33 500	66 500	17.4	670	800	68/560
	750	85	5	525 000	1 040 000	53 500	106 000	16.7	600	750	69/560
	820	115	6	735 000	1 500 000	75 000	153 000	16.2	560	670	60/560
600	730	60	3	355 000	735 000	36 000	75 000	17.5	600	710	68/600
	800	90	5	550 000	1 160 000	56 500	118 000	16.9	560	670	69/600
	870	118	6	790 000	1 640 000	80 500	168 000	16.1	530	630	60/600

Abutment and Fillet Dimensions (mm)			Mass (kg)
$d_a^{(1)}$ min	$D_a^{(1)}$ max	$r_a$ max	
391	469	2	19.5
396	504	3	40
400	540	4	68
411	489	2	20.5
416	524	3	42
420	580	4	88.4
431	509	2	21.4
436	544	3	43.6
440	600	4	92.2
451	529	2	22.3
456	584	3	60.2
466	624	5	106
473	567	2.5	34.3
476	604	3	62.6
486	654	5	123
493	587	2.5	35.4
500	630	4	73.5
506	674	5	127
513	607	2.5	37.2
520	650	4	82
526	694	5	131
543	637	2.5	39.8
550	690	4	89.8
556	754	5	184
573	667	2.5	41.5
580	730	4	105
586	793.5	5	203
613	717	2.5	50.9
620	780	4	120
626	844	5	236

Note (1) When heavy axial loads are applied, increase  $d_a$  and decrease  $D_a$  from the above values.

# SINGLE-ROW DEEP GROOVE BALL BEARINGS

Bore Diameter 630~800 mm

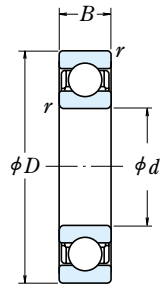

Open Type

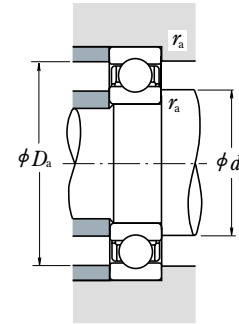

## Dynamic Equivalent Load

$$P = XF_r + YF_a$$

$\frac{f_0 F_a}{C_{0r}}$	$e$	$\frac{F_a}{F_r} \leq e$		$\frac{F_a}{F_r} > e$	
		X	Y	X	Y
0.172	0.19	1	0	0.56	2.30
0.345	0.22	1	0	0.56	1.99
0.689	0.26	1	0	0.56	1.71
1.03	0.28	1	0	0.56	1.55
1.38	0.30	1	0	0.56	1.45
2.07	0.34	1	0	0.56	1.31
3.45	0.38	1	0	0.56	1.15
5.17	0.42	1	0	0.56	1.04
6.89	0.44	1	0	0.56	1.00

## Static Equivalent Load

$$\frac{F_a}{F_r} > 0.8, P_0 = 0.6F_r + 0.5F_a$$

$$\frac{F_a}{F_r} \leq 0.8, P_0 = F_r$$

Boundary Dimensions (mm)				Basic Load Ratings				Factor	Limiting Speeds (rpm)		Bearing Numbers
$d$	$D$	$B$	$r_{\min}$	(N)		{kgf}			Grease	Oil	
<b>630</b>	780	69	4	420 000	890 000	43 000	90 500	17.3	560	670	<b>68/630</b>
	850	100	6	625 000	1 350 000	64 000	138 000	16.7	530	630	<b>69/630</b>
	920	128	7.5	750 000	1 620 000	76 500	165 000	16.4	480	600	<b>60/630</b>
<b>670</b>	820	69	4	435 000	965 000	44 500	98 000	17.4	500	630	<b>68/670</b>
	900	103	6	675 000	1 460 000	68 500	149 000	16.7	480	560	<b>69/670</b>
	980	136	7.5	765 000	1 730 000	78 000	177 000	16.6	450	530	<b>60/670</b>
<b>710</b>	870	74	4	480 000	1 100 000	49 000	113 000	17.4	480	560	<b>68/710</b>
	950	106	6	715 000	1 640 000	72 500	167 000	16.8	450	530	<b>69/710</b>
<b>750</b>	920	78	5	525 000	1 260 000	53 500	128 000	17.4	430	530	<b>68/750</b>
	1 000	112	6	785 000	1 840 000	80 000	188 000	16.7	400	500	<b>69/750</b>
<b>800</b>	980	82	5	530 000	1 310 000	54 000	133 000	17.5	400	480	<b>68/800</b>
	1 060	115	6	825 000	2 050 000	84 500	209 000	16.8	380	450	<b>69/800</b>

Note (1) When heavy axial loads are applied, increase  $d_a$  and decrease  $D_a$  from the above values.

Abutment and Fillet Dimensions (mm)			Mass (kg)
$d_a^{(1)}$ min	$D_a^{(1)}$ max	$r_a$ max	
646	764	3	71.3
656	824	5	163
662	888	6	285
686	804	3	75.4
696	874	5	181
702	948	6	351
726	854	3	92.6
736	924	5	208
770	900	4	110
776	974	5	245
820	960	4	132
826	1 034	5	275

# MAXIMUM TYPE BALL BEARINGS

Bore Diameter 25~110 mm

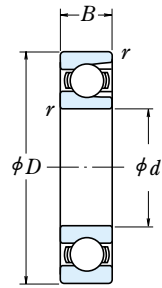

Open Type



Shielded Type  
(One Shield) Z



Shielded Type  
(Two Shields) ZZ

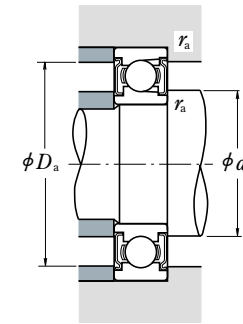
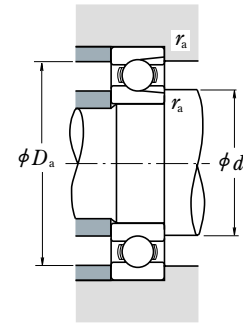

Boundary Dimensions (mm)				Basic Load Ratings (N) (kgf)				Limiting Speeds (rpm)		Open
d	D	B	r min	C <sub>r</sub>	C <sub>0r</sub>	C <sub>r</sub>	C <sub>0r</sub>	Grease Open Z · ZZ	Oil Open Z	
25	52	15	1	14 400	10 500	1 470	1 070	12 000	15 000	BL 205 BL 305
	62	17	1.1	21 500	15 500	2 200	1 580	11 000	13 000	
30	62	16	1	21 000	16 300	2 150	1 660	10 000	12 000	BL 206 BL 306
	72	19	1.1	27 900	20 700	2 840	2 110	9 000	11 000	
35	72	17	1.1	27 800	22 100	2 830	2 250	9 000	11 000	BL 207 BL 307
	80	21	1.5	37 000	29 100	3 800	2 970	8 000	9 500	
40	80	18	1.1	35 500	28 800	3 600	2 940	8 000	9 500	BL 208 BL 308
	90	23	1.5	46 500	36 000	4 750	3 650	7 500	9 000	
45	85	19	1.1	37 000	32 000	3 800	3 250	7 500	9 000	BL 209 BL 309
	100	25	1.5	55 500	44 000	5 650	4 500	6 300	8 000	
50	90	20	1.1	39 000	35 000	3 950	3 550	6 700	8 500	BL 210 BL 310
	110	27	2	65 000	52 500	6 600	5 350	6 000	7 100	
55	100	21	1.5	48 000	44 000	4 900	4 500	6 300	7 500	BL 211 BL 311
	120	29	2	75 000	61 500	7 650	6 250	5 600	6 700	
60	110	22	1.5	58 000	54 000	5 950	5 550	5 600	6 700	BL 212 BL 312
	130	31	2.1	85 500	71 500	8 700	7 300	5 000	6 000	
65	120	23	1.5	63 500	60 000	6 450	6 150	5 300	6 300	BL 213 BL 313
	140	33	2.1	103 000	89 500	10 500	9 150	4 800	5 600	
70	125	24	1.5	69 000	66 000	7 050	6 750	5 000	6 000	BL 214 BL 314
	150	35	2.1	115 000	102 000	11 800	10 400	4 300	5 300	
75	130	25	1.5	72 000	72 000	7 350	7 300	4 500	5 600	BL 215 BL 315
	160	37	2.1	126 000	116 000	12 800	11 800	4 000	5 000	
80	140	26	2	84 000	85 000	8 600	8 650	4 300	5 300	BL 216 BL 316
	170	39	2.1	136 000	130 000	13 900	13 300	3 800	4 500	
85	150	28	2	93 000	93 000	9 500	9 450	4 000	5 000	BL 217 BL 317
	180	41	3	147 000	145 000	15 000	14 800	3 600	4 300	
90	160	30	2	107 000	107 000	10 900	10 900	3 800	4 500	BL 218 BL 318
	190	43	3	158 000	161 000	16 100	16 400	3 400	4 000	
95	170	32	2.1	121 000	123 000	12 300	12 500	3 600	4 300	BL 219 BL 319
	200	45	3	169 000	178 000	17 300	18 100	2 800	3 600	
100	180	34	2.1	136 000	140 000	13 800	14 200	3 400	4 000	BL 220
105	190	36	2.1	148 000	157 000	15 000	16 000	3 200	3 800	BL 221
110	200	38	2.1	160 000	176 000	16 300	17 900	2 800	3 400	BL 222

Remarks When using Maximum Type Ball Bearings, please contact NSK.

Bearing Numbers		Abutment and Fillet Dimensions (mm)				Mass (kg) approx
With One Shielded	With Two Shields	d <sub>a</sub> min	d <sub>b</sub> max	D <sub>a</sub> max	r <sub>a</sub> max	
BL 205 Z	BL 205 ZZ	30	32	47	1	0.133
BL 305 Z	BL 305 ZZ	31.5	36	55.5	1	0.246
BL 206 Z	BL 206 ZZ	35	38.5	57	1	0.215
BL 306 Z	BL 306 ZZ	36.5	42	65.5	1	0.364
BL 207 Z	BL 207 ZZ	41.5	44.5	65.5	1	0.307
BL 307 Z	BL 307 ZZ	43	44.5	72	1.5	0.486
BL 208 Z	BL 208 ZZ	46.5	50	73.5	1	0.394
BL 308 Z	BL 308 ZZ	48	52.5	82	1.5	0.685
BL 209 Z	BL 209 ZZ	51.5	55.5	78.5	1	0.449
BL 309 Z	BL 309 ZZ	53	61.5	92	1.5	0.883
BL 210 Z	BL 210 ZZ	56.5	60	83.5	1	0.504
BL 310 Z	BL 310 ZZ	59	68	101	2	1.16
BL 211 Z	BL 211 ZZ	63	66.5	92	1.5	0.667
BL 311 Z	BL 311 ZZ	64	72.5	111	2	1.49
BL 212 Z	BL 212 ZZ	68	74.5	102	1.5	0.856
BL 312 Z	BL 312 ZZ	71	79	119	2	1.88
BL 213 Z	BL 213 ZZ	73	80	112	1.5	1.09
BL 313 Z	BL 313 ZZ	76	85.5	129	2	2.36
BL 214 Z	BL 214 ZZ	78	84	117	1.5	1.19
BL 314 Z	BL 314 ZZ	81	92	139	2	2.87
BL 215 Z	BL 215 ZZ	83	90	122	1.5	1.29
BL 315 Z	BL 315 ZZ	86	98.5	149	2	3.43
BL 216 Z	BL 216 ZZ	89	95.5	131	2	1.61
BL 316 Z	BL 316 ZZ	91	104.5	159	2	4.08
BL 217 Z	BL 217 ZZ	94	102	141	2	1.97
BL 317 Z	BL 317 ZZ	98	110.5	167	2.5	4.77
BL 218 Z	BL 218 ZZ	99	107.5	151	2	2.43
BL 318 Z	BL 318 ZZ	103	117	177	2.5	5.45
BL 219 Z	BL 219 ZZ	106	114	159	2	2.95
BL 319 Z	BL 319 ZZ	108	124	187	2.5	6.4
BL 220 Z	BL 220 ZZ	111	121.5	169	2	3.54
BL 221 Z	BL 221 ZZ	116	127.5	179	2	4.23
—	—	121	—	189	2	4.84

Bore Diameter 4~20 mm

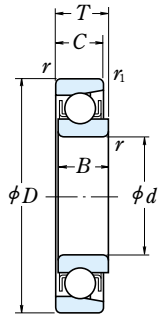

Outside Diameter Tolerance (Class N)

Units : μm

Nominal Outside Diameter D (mm)		Single Plane Mean Outside Diameter ΔD <sub>mp</sub>			
		E Series		EN Series	
Over	Incl	High	Low	High	Low
—	10	+ 8	0	0	- 8
10	18	+ 8	0	0	- 8
18	30	+ 9	0	0	- 9
30	50	+11	0	0	-11

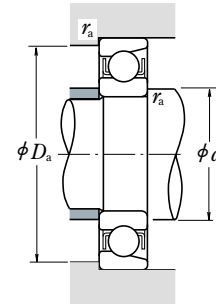

Dynamic Equivalent Load

$$P = XF_r + YF_a$$

$F_a/F_r \leq e$		$F_a/F_r > e$		$e$
X	Y	X	Y	
1	0	0.5	2.5	0.2

Boundary Dimensions (mm)					Basic Load Ratings (N) (kgf)				Limiting Speeds (rpm)		Bearing Numbers	
d	D	B,C,T	r <sub>min</sub>	r <sub>1 min</sub>	C <sub>r</sub>	C <sub>0r</sub>	C <sub>r</sub>	C <sub>0r</sub>	Grease	Oil	E Series	EN Series
<b>4</b>	16	5	0.15	0.1	1 650	288	168	29	34 000	40 000	<b>E 4</b>	<b>EN 4</b>
<b>5</b>	16	5	0.15	0.1	1 650	288	168	29	34 000	40 000	<b>E 5</b>	<b>EN 5</b>
<b>6</b>	21	7	0.3	0.15	2 490	445	254	46	30 000	36 000	<b>E 6</b>	<b>EN 6</b>
<b>7</b>	22	7	0.3	0.15	2 490	445	254	46	30 000	36 000	<b>E 7</b>	<b>EN 7</b>
<b>8</b>	24	7	0.3	0.15	3 450	650	350	66	28 000	34 000	<b>E 8</b>	<b>EN 8</b>
<b>9</b>	28	8	0.3	0.15	4 550	880	465	90	24 000	30 000	<b>E 9</b>	<b>EN 9</b>
<b>10</b>	28	8	0.3	0.15	4 550	880	465	90	24 000	30 000	<b>E 10</b>	<b>EN 10</b>
<b>11</b>	32	7	0.3	0.15	4 400	845	450	86	22 000	26 000	<b>E 11</b>	<b>EN 11</b>
<b>12</b>	32	7	0.3	0.15	4 400	845	450	86	22 000	26 000	<b>E 12</b>	<b>EN 12</b>
<b>13</b>	30	7	0.3	0.15	4 400	845	450	86	22 000	26 000	<b>E 13</b>	<b>EN 13</b>
<b>14</b>	35	8	0.3	0.15	5 800	1 150	590	117	19 000	22 000	—	<b>EN 14</b>
<b>15</b>	35	8	0.3	0.15	5 800	1 150	590	117	19 000	22 000	<b>E 15</b>	<b>EN 15</b>
	40	10	0.6	0.3	7 400	1 500	750	153	17 000	20 000	<b>BO 15</b>	—
<b>16</b>	38	10	0.6	0.2	6 900	1 380	705	141	17 000	22 000	—	<b>EN 16</b>
<b>17</b>	40	10	0.6	0.3	7 400	1 500	750	153	17 000	20 000	<b>L 17</b>	—
	44	11	0.6	0.3	7 350	1 500	750	153	16 000	19 000	—	<b>EN 17</b>
	44	11	0.6	0.3	7 350	1 500	750	153	16 000	19 000	<b>BO 17</b>	—
<b>18</b>	40	9	0.6	0.2	5 050	1 030	515	105	17 000	20 000	—	<b>EN 18</b>
<b>19</b>	40	9	0.6	0.2	5 050	1 030	515	105	17 000	20 000	<b>E 19</b>	<b>EN 19</b>
<b>20</b>	47	12	1	0.6	11 000	2 380	1 120	243	14 000	17 000	<b>E 20</b>	<b>EN 20</b>
	47	14	1	0.6	11 000	2 380	1 120	243	14 000	17 000	<b>L 20</b>	—

Abutment and Fillet Dimensions (mm)			Mass (kg)
d <sub>a min</sub>	D <sub>a max</sub>	r <sub>a max</sub>	
5.2	14.8	0.15	0.005
6.2	14.8	0.15	0.004
8	19	0.3	0.011
9	20	0.3	0.013
10	22	0.3	0.014
11	26	0.3	0.022
12	26	0.3	0.021
13	30	0.3	0.029
14	30	0.3	0.028
15	28	0.3	0.021
16	33	0.3	0.035
17	33	0.3	0.034
19	36	0.6	0.055
20	34	0.6	0.049
21	36	0.6	0.051
21	40	0.6	0.080
21	40	0.6	0.080
22	36	0.6	0.051
23	36	0.6	0.049
25	42	1	0.089
25	42	1	0.101

- Remarks**
1. The outside diameters of Magneto Bearings Series E always have plus tolerances.
  2. When using Magneto Bearings other than E, please contact NSK.

## EXTRA SMALL BALL BEARINGS AND MINIATURE BALL BEARINGS

### EXTRA SMALL BALL BEARINGS · MINIATURE BALL BEARINGS

Metric Design	Bore Diameter 1~9mm.....Pages B34 to B37
With Flange	Bore Diameter 1~9mm.....Pages B38 to B41
Inch Design	Bore Diameter 1.016~9.525mm .....Pages B42 to B43
With Flange	Bore Diameter 1.191~9.525mm .....Pages B44 to B45

### DESIGN AND TYPES

The size ranges of extra small and miniature ball bearings are shown in Table 1. The design, types, and type symbols are shown in Table 2. Those types among them that are listed in the bearing tables are indicated by the shading   in Table 2.

**Table 1 Size Ranges of Bearings**

Units : mm

Design	Extra Small Ball Bearings	Miniature Ball Bearings
Metric	Outside diameter $D \geq 9$ Bore diameter $d < 10$	Outside diameter $D < 9$
Inch	Outside diameter $D \geq 9.525$ Bore diameter $d < 10$	Outside diameter $D < 9.525$

Please refer to NSK Miniature Ball Bearings (CAT. No. E126) for details.

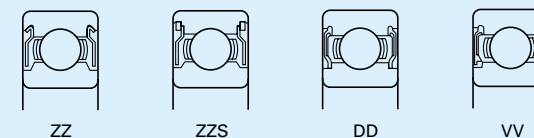
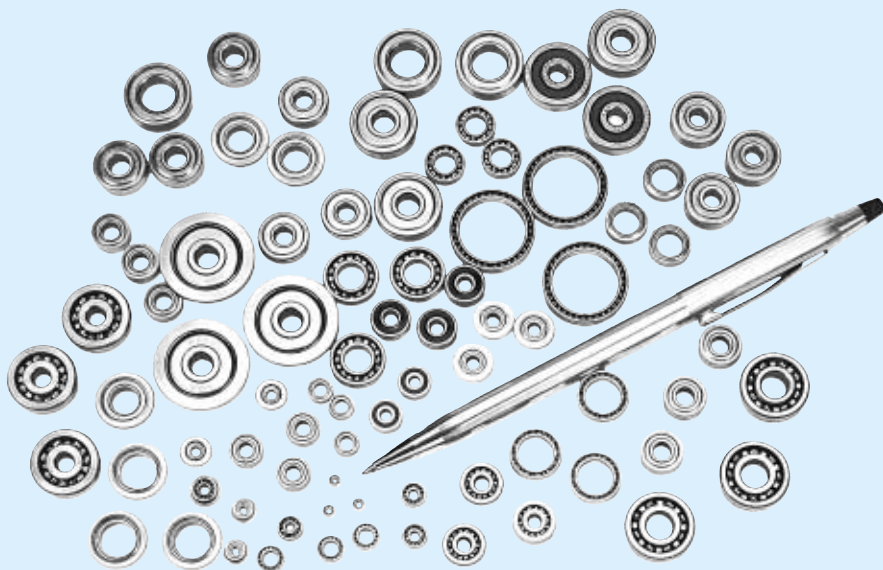









Table 2 Design, Types, and Type Symbols

Design · Types	Type Symbols				Remarks
	Metric	Inch	Special		
			Metric	Inch	
	6 0 0	R	MR	—	Shielded · sealed bearings are available.
Thin section 	—	—	SMT	—	
With flange 	F6 0 0	FR	MF	—	Shielded · sealed bearings are available.
Extended inner ring 	—	—	—	RW	Shielded bearings are available.
With flange and extended inner ring 	—	—	—	FRW	Shielded bearings are available.
For synchro motors 	—	—	—	SR00X00	Shielded bearings are available.
Pivot Ball Bearings 	—	—	BCF	—	
Thrust Ball Bearings 	—	—	F	—	

Remarks Single-row angular contact ball bearings are available besides those shown above.

TOLERANCES AND RUNNING ACCURACY

METRIC DESIGN BEARINGS .....Table 8.2(Pages A60 to A63)

The flange tolerances for metric design bearings are listed in Table 3.

Table 3 Flange Tolerances for Metric Flanged Bearings

(1) Tolerances of Flange Outside Diameter Units :  $\mu\text{m}$

Nominal Flange Outside Diameter $D_1(\text{mm})$		Deviation of Flange Outside Diameter $\Delta D_{1S}$			
		①		②	
over	incl	high	low	high	low
10	18	+220	-36	0	-36
10	18	+270	-43	0	-43
18	30	+330	-52	0	-52

Remarks ②is applied when the flange outside diameter is used for positioning.

(2) Flange Width Tolerances and Running Accuracies Related to Flange Units :  $\mu\text{m}$

Nominal Bearing Outside Diameter $D$ (mm)	Deviation of Flange Width $\Delta C_{1S}$	Variation of Flange Width $\Delta C_{1S}$			Variation of Bearing Outside Surface Generatrix Inclination with Flange Backface $S_{D1}$			Flange Backface Runout with Raceway $S_{ea1}$				
		Normal and Classes 6,5,4,2	Class 5	Class 4	Class 2	Class 5	Class 4	Class 2	Class 5	Class 4	Class 2	
over	incl	high	low	max	max	max	max	max	max	max		
2.5 <sup>(1)</sup>	6	Use the $\Delta B_S$ tolerance for $d$ of the same bearing of the same class	Use the $\Delta V_{BS}$ tolerance for $d$ of the same bearing of the same class	5	2.5	1.5	8	4	1.5	11	7	3
6	18			5	2.5	1.5	8	4	1.5	11	7	3
18	30			5	2.5	1.5	8	4	1.5	11	7	3

Notes (1) 2.5mm is included

INCH DESIGN BEARINGS .....Table 8.2 (Pages A60 to A63)

The flange tolerances for inch design flanged bearings are listed in Table 8.8.2 (Pages A76 and A77).

INSTRUMENT BALL BEARINGS .....Table 8.8 (Pages A76 to A77)

RECOMMENDED FITS

Please refer to NSK Miniature Ball Bearings (CAT.No.E126).

INTERNAL CLEARANCES .....Table 9.10 (Page A89)

LIMITING SPEEDS

The limiting speeds listed in the bearing tables should be adjusted depending on the bearing load conditions. Also, higher speeds are attainable by making changes in the lubrication method, cage design, etc. Refer to Page A37 for detailed information.



Metric Design  
Bore Diameter 1~4 mm

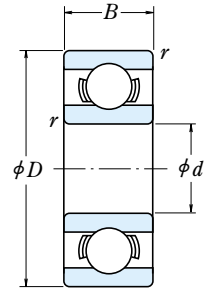

Open Type

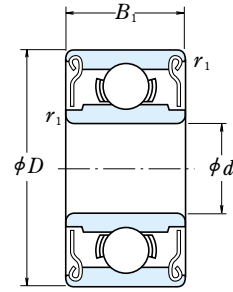

Shielded Type  
ZZ · ZZ1

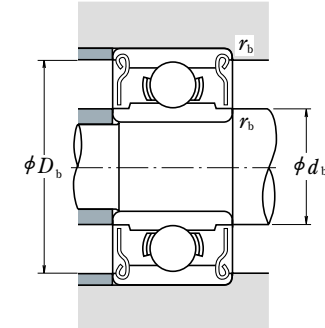
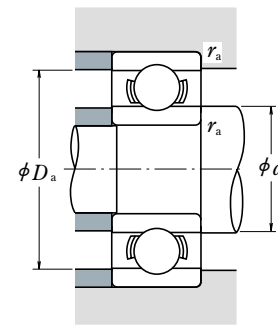

d	Boundary Dimensions (mm)					Basic Load Ratings (N) (kgf)				Limiting Speeds (rpm)		Open
	D	B	B <sub>1</sub>	r <sup>(1)</sup> <sub>min</sub>	r <sub>1</sub> <sup>(1)</sup> <sub>min</sub>	C <sub>r</sub>	C <sub>0r</sub>	C <sub>r</sub>	C <sub>0r</sub>	Grease Open ZZ	Oil Open ZZ	
1	3	1	—	0.05	—	80	23	8	2.5	130 000	150 000	<b>681</b>
	3	1.5	—	0.05	—	80	23	8	2.5	130 000	150 000	<b>MR 31</b>
	4	1.6	—	0.1	—	138	35	14	3.5	100 000	120 000	<b>691</b>
1.2	4	1.8	2.5	0.1	0.1	138	35	14	3.5	110 000	130 000	<b>MR 41 X</b>
1.5	4	1.2	2	0.05	0.05	112	33	11	3.5	100 000	120 000	<b>681 X</b>
	5	2	2.6	0.15	0.15	237	69	24	7	85 000	100 000	<b>691 X</b>
	6	2.5	3	0.15	0.15	330	98	34	10	75 000	90 000	<b>601 X</b>
2	5	1.5	2.3	0.08	0.08	169	50	17	5	85 000	100 000	<b>682</b>
	5	2	2.5	0.1	0.1	187	58	19	6	85 000	100 000	<b>MR 52 B</b>
	6	2.3	3	0.15	0.15	330	98	34	10	75 000	90 000	<b>692</b>
2.5	6	2.5	2.5	0.15	0.15	330	98	34	10	75 000	90 000	<b>MR 62</b>
	7	2.5	3	0.15	0.15	385	127	39	13	63 000	75 000	<b>MR 72</b>
	7	2.8	3.5	0.15	0.15	385	127	39	13	63 000	75 000	<b>602</b>
3	6	1.8	2.6	0.08	0.08	208	74	21	7.5	71 000	80 000	<b>682 X</b>
	7	2.5	3.5	0.15	0.15	385	127	39	13	63 000	75 000	<b>692 X</b>
	8	2.5	—	0.2	—	560	179	57	18	60 000	67 000	<b>MR 82 X</b>
4	8	2.8	4	0.15	0.15	550	175	56	18	60 000	71 000	<b>602 X</b>
	6	2	2.5	0.1	0.1	208	74	21	7.5	71 000	80 000	<b>MR 63</b>
	7	2	3	0.1	0.1	390	130	40	13	63 000	75 000	<b>683 A</b>
4	8	2.5	—	0.15	—	560	179	57	18	60 000	67 000	<b>MR 83</b>
	8	3	4	0.15	0.15	560	179	57	18	60 000	67 000	<b>693</b>
	9	2.5	4	0.2	0.15	570	187	58	19	56 000	67 000	<b>MR 93</b>
4	9	3	5	0.15	0.15	570	187	58	19	56 000	67 000	<b>603</b>
	10	4	4	0.15	0.15	630	218	64	22	50 000	60 000	<b>623</b>
	13	5	5	0.2	0.2	1 300	485	133	49	40 000	48 000	<b>633</b>
4	7	2	—	0.1	—	310	115	32	12	60 000	67 000	<b>MR 74</b>
	7	—	2.5	—	0.1	255	107	26	11	60 000	71 000	—
	8	2	3	0.15	0.1	395	139	40	14	56 000	67 000	<b>MR 84</b>
4	9	2.5	4	(0.15)	(0.15)	640	225	65	23	53 000	63 000	<b>684 A</b>
	10	3	4	0.2	0.15	710	270	73	28	50 000	60 000	<b>MR 104 B</b>
	11	4	4	0.15	0.15	960	345	98	35	48 000	56 000	<b>694</b>
4	12	4	4	0.2	0.2	960	345	98	35	48 000	56 000	<b>604</b>
	13	5	5	0.2	0.2	1 300	485	133	49	40 000	48 000	<b>624</b>
	16	5	5	0.3	0.3	1 730	670	177	68	36 000	43 000	<b>634</b>

Note (1) The values in parentheses are not based on ISO 15.

Remark 1. When using bearings with a rotating outer ring, please contact NSK if they are shielded.

Bearing Numbers		Abutment and Fillet Dimensions (mm)						Mass (g)	
Shielded	Sealed	d <sub>a</sub> <sub>min</sub>	d <sub>b</sub> <sub>max</sub>	D <sub>a</sub> <sub>max</sub>	D <sub>b</sub> <sub>min</sub>	r <sub>a</sub> <sub>max</sub>	r <sub>b</sub> <sub>max</sub>	Open	approx Shielded
—	—	1.4	—	2.6	—	0.05	—	0.03	—
—	—	1.4	—	2.6	—	0.05	—	0.04	—
—	—	1.8	—	3.2	—	0.1	—	0.09	—
<b>MR 41 XZZ</b>	—	2.0	1.9	3.2	3.5	0.1	0.1	0.10	0.14
<b>681 XZZ</b>	—	1.9	2.1	3.6	3.6	0.05	0.05	0.07	0.11
<b>691 XZZ</b>	—	2.7	2.5	3.8	4.3	0.15	0.15	0.17	0.20
<b>601 XZZ</b>	—	2.7	3.0	4.8	5.4	0.15	0.15	0.33	0.38
<b>682 ZZ</b>	—	2.6	2.7	4.4	4.2	0.08	0.08	0.12	0.17
<b>MR 52 BZZ</b>	—	2.8	2.7	4.2	4.4	0.1	0.1	0.16	0.23
<b>692 ZZ</b>	—	3.2	3.0	4.8	5.4	0.15	0.15	0.28	0.38
<b>MR 62 ZZ</b>	—	3.2	3.0	4.8	5.2	0.15	0.15	0.30	0.29
<b>MR 72 ZZ</b>	—	3.2	3.8	5.8	6.2	0.15	0.15	0.45	0.49
<b>602 ZZ</b>	—	3.2	3.8	5.8	6.2	0.15	0.15	0.51	0.58
<b>682 XZZ</b>	—	3.1	3.7	5.4	5.4	0.08	0.08	0.23	0.29
<b>692 XZZ</b>	—	3.7	3.8	5.8	6.2	0.15	0.15	0.41	0.55
—	—	4.1	—	6.4	—	0.2	—	0.56	—
<b>602 XZZ</b>	—	3.7	4.1	6.8	7.0	0.15	0.15	0.63	0.83
<b>MR 63 ZZ</b>	—	3.8	3.7	5.2	5.4	0.1	0.1	0.20	0.27
<b>683 AZZ</b>	—	3.8	4.0	6.2	6.4	0.1	0.1	0.32	0.45
—	—	4.2	—	6.8	—	0.15	—	0.54	—
<b>693 ZZ</b>	—	4.2	4.3	6.8	7.3	0.15	0.15	0.61	0.83
<b>MR 93 ZZ</b>	—	4.6	4.3	7.4	7.9	0.2	0.15	0.73	1.18
<b>603 ZZ</b>	—	4.2	4.3	7.8	7.9	0.15	0.15	0.87	1.45
<b>623 ZZ</b>	—	4.2	4.3	8.8	8.0	0.15	0.15	1.65	1.66
<b>633 ZZ</b>	—	4.6	6.0	11.4	11.3	0.2	0.2	3.38	3.33
—	—	4.8	—	6.2	—	0.1	—	0.22	—
<b>MR 74 ZZ</b>	—	—	4.8	—	6.3	—	0.1	—	0.29
<b>MR 84 ZZ</b>	—	5.2	5.0	6.8	7.4	0.15	0.1	0.36	0.56
<b>684 AZZ</b>	—	4.8	5.2	8.2	8.1	0.1	0.1	0.63	1.01
<b>MR 104 BZZ</b>	—	5.6	5.9	8.4	8.8	0.2	0.15	1.04	1.42
<b>694 ZZ</b>	—	5.2	5.6	9.8	9.9	0.15	0.15	1.7	1.75
<b>604 ZZ</b>	—	5.6	5.6	10.4	9.9	0.2	0.2	2.25	2.29
<b>624 ZZ</b>	—	5.6	6.0	11.4	11.3	0.2	0.2	3.03	3.04
<b>634 ZZ1</b>	—	6.0	7.5	14.0	13.8	0.3	0.3	5.24	5.21

Metric Design  
Bore Diameter 5~9 mm

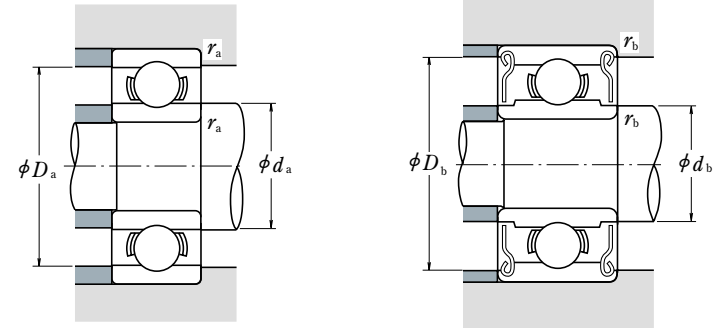
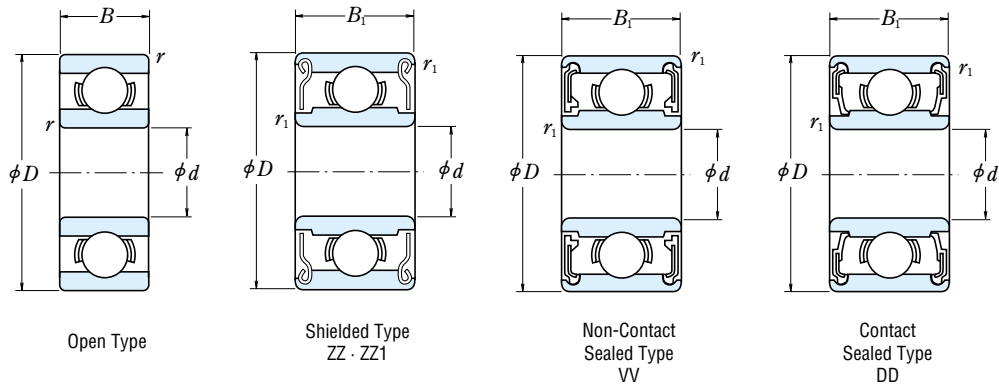

Boundary Dimensions (mm)					Basic Load Ratings (N) (kgf)				Limiting Speeds (rpm)			Open	
d	D	B	B <sub>1</sub>	r <sup>(1)</sup> <sub>min</sub>	r <sub>1</sub> <sup>(1)</sup> <sub>min</sub>	C <sub>r</sub>	C <sub>0r</sub>	C <sub>r</sub>	C <sub>0r</sub>	Grease	Oil		
											Open Z	Open	
5	8	2	—	0.1	—	310	120	31	12	53 000	—	63 000	MR 85
	8	—	2.5	—	0.1	278	131	28	13	53 000	—	63 000	—
	9	2.5	3	0.15	0.15	430	168	44	17	50 000	—	60 000	MR 95
	10	3	4	0.15	0.15	430	168	44	17	50 000	—	60 000	MR 105
	11	—	4	—	0.15	715	276	73	28	48 000	—	56 000	—
	11	3	5	0.15	0.15	715	281	73	29	45 000	—	53 000	685
	13	4	4	0.2	0.2	1 080	430	110	44	43 000	40 000	50 000	695
	14	5	5	0.2	0.2	1 330	505	135	52	40 000	38 000	50 000	605
	16	5	5	0.3	0.3	1 730	670	177	68	36 000	32 000	43 000	625
	19	6	6	0.3	0.3	2 340	885	238	90	32 000	30 000	40 000	635
6	10	2.5	3	0.15	0.1	495	218	51	22	45 000	—	53 000	MR 106
	12	3	4	0.2	0.15	715	292	73	30	43 000	40 000	50 000	MR 126
	13	3.5	5	0.15	0.15	1 080	440	110	45	40 000	38 000	50 000	686 A
	15	5	5	0.2	0.2	1 730	670	177	68	40 000	36 000	45 000	696
	17	6	6	0.3	0.3	2 260	835	231	85	38 000	34 000	45 000	606
	19	6	6	0.3	0.3	2 340	885	238	90	32 000	30 000	40 000	626
	22	7	7	0.3	0.3	3 300	1 370	335	140	30 000	28 000	36 000	636
	11	2.5	3	0.15	0.1	455	201	47	21	43 000	—	50 000	MR 117
	13	3	4	0.2	0.15	540	276	55	28	40 000	—	48 000	MR 137
	14	3.5	5	0.15	0.15	1 170	510	120	52	40 000	34 000	45 000	687
7	17	5	5	0.3	0.3	1 610	710	164	73	36 000	28 000	43 000	697
	19	6	6	0.3	0.3	2 340	885	238	90	36 000	32 000	43 000	607
	22	7	7	0.3	0.3	3 300	1 370	335	140	30 000	28 000	36 000	627
	26	9	9	0.3	0.3	4 550	1 970	465	201	28 000	22 000	34 000	637
	12	2.5	3.5	0.15	0.1	545	274	56	28	40 000	—	48 000	MR 128
	14	3.5	4	0.2	0.15	820	385	83	39	38 000	32 000	45 000	MR 148
	16	4	5	0.2	0.2	1 610	710	164	73	36 000	28 000	43 000	688 A
	19	6	6	0.3	0.3	2 240	910	228	93	36 000	28 000	43 000	698
	22	7	7	0.3	0.3	3 300	1 370	335	140	34 000	28 000	40 000	608
	24	8	8	0.3	0.3	3 350	1 430	340	146	28 000	24 000	34 000	628
8	28	9	9	0.3	0.3	4 550	1 970	465	201	28 000	22 000	34 000	638
	17	4	5	0.2	0.2	1 330	665	136	68	36 000	24 000	43 000	689
	20	6	6	0.3	0.3	1 720	840	175	86	34 000	24 000	40 000	699
	24	7	7	0.3	0.3	3 350	1 430	340	146	32 000	24 000	38 000	609
	26	8	8	(0.6)	(0.6)	4 550	1 970	465	201	28 000	22 000	34 000	629
	30	10	10	0.6	0.6	5 100	2 390	520	244	24 000	—	30 000	639

Bearing Numbers		Abutment and Fillet Dimensions (mm)						Mass (g)	
Shielded	Sealed	d <sub>a</sub> <sub>min</sub>	d <sub>b</sub> <sub>max</sub>	D <sub>a</sub> <sub>max</sub>	D <sub>b</sub> <sub>min</sub>	r <sub>a</sub> <sub>max</sub>	r <sub>b</sub> <sub>max</sub>	Open	approx Shielded
—	—	5.8	—	7.2	—	0.1	—	0.26	—
MR 85 ZZ	—	—	5.8	—	7.4	—	0.1	—	0.34
MR 95 ZZ1	—	6.2	6.0	7.8	8.2	0.15	0.15	0.50	0.58
MR 105 ZZ	—	6.2	6.0	8.8	8.4	0.15	0.15	0.95	1.29
MR 115 ZZ	VV	—	6.3	—	9.8	—	0.15	—	1.49
685 ZZ	—	6.2	6.2	9.8	9.9	0.15	0.15	1.2	1.96
695 ZZ	VV DD	6.6	6.6	11.4	11.2	0.2	0.2	2.45	2.5
605 ZZ	— DD	6.6	6.9	12.4	12.2	0.2	0.2	3.54	3.48
625 ZZ1	VV DD	7.0	7.5	14.0	13.8	0.3	0.3	4.95	4.86
635 ZZ1	VV DD	7.0	8.5	17.0	16.5	0.3	0.3	8.56	8.34
MR 106 ZZ1	—	7.2	7.0	8.8	9.3	0.15	0.1	0.56	0.68
MR 126 ZZ	— DD	7.6	7.2	10.4	10.9	0.2	0.15	1.27	1.74
686 AZZ	VV DD	7.2	7.4	11.8	11.7	0.15	0.15	1.91	2.69
696 ZZ1	VV DD	7.6	7.9	13.4	13.3	0.2	0.2	3.88	3.72
606 ZZ	VV DD	8.0	8.2	15.0	14.8	0.3	0.3	5.97	6.08
626 ZZ1	VV DD	8.0	8.5	17.0	16.5	0.3	0.3	8.15	7.94
636 ZZ	VV DD	8.0	10.5	20.0	19.0	0.3	0.3	14	14
MR 117 ZZ	—	8.2	8.0	9.8	10.5	0.15	0.1	0.62	0.72
MR 137 ZZ	—	8.6	9.0	11.4	11.6	0.2	0.15	1.58	2.02
687 ZZ1	VV DD	8.2	8.5	12.8	12.7	0.15	0.15	2.13	2.97
697 ZZ1	VV DD	9.0	10.2	15.0	14.8	0.3	0.3	5.26	5.12
607 ZZ1	VV DD	9.0	9.1	17.0	16.5	0.3	0.3	7.67	7.51
627 ZZ	VV DD	9.0	10.5	20.0	19.0	0.3	0.3	12.7	12.9
637 ZZ1	VV DD	9.0	12.8	24.0	22.8	0.3	0.3	24	25
MR 128 ZZ1	—	9.2	9.0	10.8	11.3	0.15	0.1	0.71	0.97
MR 148 ZZ	VV DD	9.6	9.2	12.4	12.8	0.2	0.15	1.86	2.16
688 AZZ1	VV DD	9.6	10.2	14.4	14.2	0.2	0.2	3.12	4.02
698 ZZ	VV DD	10.0	10.0	17.0	16.5	0.3	0.3	7.23	7.18
608 ZZ	VV DD	10.0	10.5	20.0	19.0	0.3	0.3	12.1	12.2
628 ZZ	VV DD	10.0	12.0	22.0	20.5	0.3	0.3	17.2	17.4
638 ZZ1	VV DD	10.0	12.8	26.0	22.8	0.3	0.3	28.3	28.6
689 ZZ1	VV DD	10.6	11.5	15.4	15.2	0.2	0.2	3.53	4.43
699 ZZ1	VV DD	11.0	12.0	18.0	17.2	0.3	0.3	8.45	8.33
609 ZZ	VV DD	11.0	12.0	22.8	20.5	0.3	0.3	14.5	14.7
629 ZZ	VV DD	11.0	12.8	24.0	22.8	0.3	0.3	19.5	19.3
639 ZZ	VV	13.0	16.1	26.0	25.6	0.6	0.6	36.5	36

Note (1) The values in parentheses are not based on ISO 15.

Remarks 1. When using bearings with a rotating outer ring, please contact NSK if they are sealed or shielded.  
2. Bearings with snap rings are also available, please contact NSK.

Metric Design With Flange  
Bore Diameter 1~4 mm

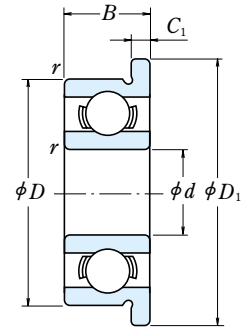

Open Type

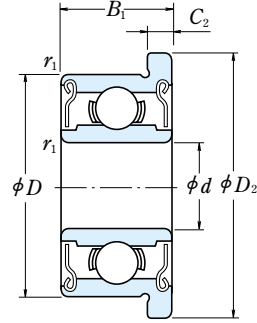

Shielded Type  
ZZ · ZZ1

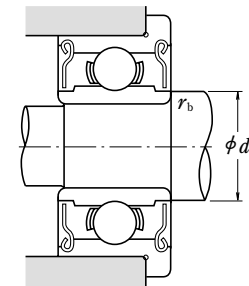
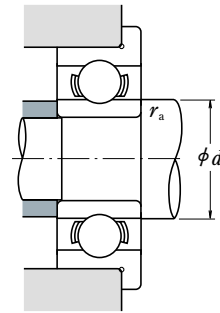

d	Boundary Dimensions (mm)								Basic Load Ratings (N) {kgf}				Limiting Speeds (rpm)		
	D	D <sub>1</sub>	D <sub>2</sub>	B	B <sub>1</sub>	C <sub>1</sub>	C <sub>2</sub>	r <sup>(1)</sup> <sub>min</sub>	r <sub>1</sub> <sup>(1)</sup> <sub>min</sub>	C <sub>r</sub>	C <sub>0r</sub>	C <sub>r</sub>	C <sub>0r</sub>	Grease Open Z · ZZ	Oil Open Z
1	3	3.8	—	1	—	0.3	—	0.05	—	80	23	8	2.5	130 000	150 000
	4	5	—	1.6	—	0.5	—	0.1	—	140	36	14	3.5	100 000	120 000
1.2	4	4.8	—	1.8	—	0.4	—	0.1	—	138	35	14	3.5	110 000	130 000
1.5	4	5	5	1.2	2	0.4	0.6	0.05	0.05	112	33	11	3.5	100 000	120 000
	5	6.5	6.5	2	2.6	0.6	0.8	0.15	0.15	237	69	24	7	85 000	100 000
	6	7.5	7.5	2.5	3	0.6	0.8	0.15	0.15	330	98	34	10	75 000	90 000
2	5	6.1	6.1	1.5	2.3	0.5	0.6	0.08	0.08	169	50	17	5	85 000	100 000
	5	6.2	6.2	2	2.5	0.6	0.6	0.1	0.1	187	58	19	6	85 000	100 000
	6	7.5	7.5	2.3	3	0.6	0.8	0.15	0.15	330	98	34	10	75 000	90 000
6	7.2	—	2.5	—	0.6	—	0.15	—	—	330	98	34	10	75 000	90 000
	8.2	8.2	2.5	3	0.6	0.6	0.15	0.15	385	127	39	13	63 000	75 000	
	8.5	8.5	2.8	3.5	0.7	0.9	0.15	0.15	385	127	39	13	63 000	75 000	
2.5	6	7.1	7.1	1.8	2.6	0.5	0.8	0.08	0.08	208	74	21	7.5	71 000	80 000
	7	8.5	8.5	2.5	3.5	0.7	0.9	0.15	0.15	385	127	39	13	63 000	75 000
	8	9.2	—	2.5	—	0.6	—	0.2	—	560	179	57	18	60 000	67 000
8	9.5	9.5	2.8	4	0.7	0.9	0.15	0.15	550	175	56	18	60 000	71 000	
	6	7.2	7.2	2	2.5	0.6	0.6	0.1	0.1	208	74	21	7.5	71 000	80 000
	7	8.1	8.1	2	3	0.5	0.8	0.1	0.1	390	130	40	13	63 000	75 000
8	9.2	—	2.5	—	0.6	—	0.15	—	—	560	179	57	18	60 000	67 000
	9.5	9.5	3	4	0.7	0.9	0.15	0.15	560	179	57	18	60 000	67 000	
	10.2	10.6	2.5	4	0.6	0.8	0.2	0.15	570	187	58	19	56 000	67 000	
9	10.5	10.5	3	5	0.7	1	0.15	0.15	570	187	58	19	56 000	67 000	
	11.5	11.5	4	4	1	1	0.15	0.15	630	218	64	22	50 000	60 000	
	13	15	15	5	5	1	1	0.2	0.2	1 300	485	133	49	36 000	43 000
4	7	8.2	—	2	—	0.6	—	0.1	—	310	115	32	12	60 000	67 000
	7	—	8.2	—	2.5	—	0.6	—	0.1	255	107	26	11	60 000	71 000
	8	9.2	9.2	2	3	0.6	0.6	0.15	0.1	395	139	40	14	56 000	67 000
9	10.3	10.3	2.5	4	0.6	1	(0.15)	(0.15)	640	225	65	23	53 000	63 000	
	10	11.2	11.6	3	4	0.6	0.8	0.2	0.15	710	270	73	28	50 000	60 000
	11	12.5	12.5	4	4	1	1	0.15	0.15	960	345	98	35	48 000	56 000
12	13.5	13.5	4	4	1	1	0.2	0.2	960	345	98	35	48 000	56 000	
	13	15	15	5	5	1	1	0.2	0.2	1 300	485	133	49	40 000	48 000
	16	18	18	5	5	1	1	0.3	0.3	1 730	670	177	68	36 000	43 000

Bearing Numbers			Abutment and Fillet Dimensions (mm)				Mass (g)	
Open	Shielded	Sealed	d <sub>a</sub> <sub>min</sub>	d <sub>b</sub> <sub>max</sub>	r <sub>a</sub> <sub>max</sub>	r <sub>b</sub> <sub>max</sub>	Open	Shielded
F 681	—	—	1.4	—	0.05	—	0.04	—
F 691	—	—	1.8	—	0.1	—	0.14	—
MF 41 X	—	—	2.0	—	0.1	—	0.12	—
F 681 X	F 681 XZZ	—	1.9	2.1	0.05	0.05	0.09	0.14
F 691 X	F 691 XZZ	—	2.7	2.5	0.15	0.15	0.23	0.28
F 601 X	F 601 XZZ	—	2.7	3.0	0.15	0.15	0.42	0.52
F 682	F 682 ZZ	—	2.6	2.7	0.08	0.08	0.16	0.22
MF 52 B	MF 52 BZZ	—	2.8	2.7	0.1	0.1	0.21	0.27
F 692	F 692 ZZ	—	3.2	3.0	0.15	0.15	0.35	0.48
MF 62	—	—	3.2	—	0.15	—	0.36	—
MF 72	MF 72 ZZ	—	3.2	3.8	0.15	0.15	0.52	0.56
F 602	F 602 ZZ	—	3.2	3.1	0.15	0.15	0.60	0.71
F 682 X	F 682 XZZ	—	3.1	3.7	0.08	0.08	0.25	0.36
F 692 X	F 692 XZZ	—	3.7	3.8	0.15	0.15	0.51	0.68
MF 82 X	—	—	4.1	—	0.2	—	0.62	—
F 602 X	F 602 XZZ	—	3.7	3.5	0.15	0.15	0.74	0.98
MF 63	MF 63 ZZ	—	3.8	3.7	0.1	0.1	0.27	0.33
F 683 A	F 683 AZZ	—	3.8	4.0	0.1	0.1	0.37	0.53
MF 83	—	—	4.2	—	0.15	—	0.56	—
F 693	F 693 ZZ	—	4.2	4.3	0.15	0.15	0.70	0.97
MF 93	MF 93 ZZ	—	4.6	4.3	0.2	0.15	0.81	1.34
F 603	F 603 ZZ	—	4.2	4.3	0.15	0.15	1.0	1.63
F 623	F 623 ZZ	—	4.2	4.3	0.15	0.15	1.85	1.86
F 633	F 633 ZZ	—	4.6	6.0	0.2	0.2	3.73	3.59
MF 74	—	—	4.8	—	0.1	—	0.29	—
—	MF 74 ZZ	—	—	4.8	—	0.1	—	0.35
MF 84	MF 84 ZZ	—	5.2	5.0	0.15	0.1	0.44	0.63
F 684	F 684 ZZ	—	4.8	5.2	0.1	0.1	0.70	1.14
MF 104 B	MF 104 BZZ	—	5.6	5.9	0.2	0.15	1.13	1.59
F 694	F 694 ZZ	—	5.2	5.6	0.15	0.15	1.91	1.96
F 604	F 604 ZZ	—	5.6	5.6	0.2	0.2	2.53	2.53
F 624	F 624 ZZ	—	5.6	6.0	0.2	0.2	3.38	3.53
F 634	F 634 ZZ1	—	6.0	7.5	0.3	0.3	5.73	5.62

Note (1) The values in parentheses are not based on ISO 15.

Remark 1. When using bearings with a rotating outer ring, please contact NSK if they are shielded.

Metric Design With Flange  
Bore Diameter 5~9 mm

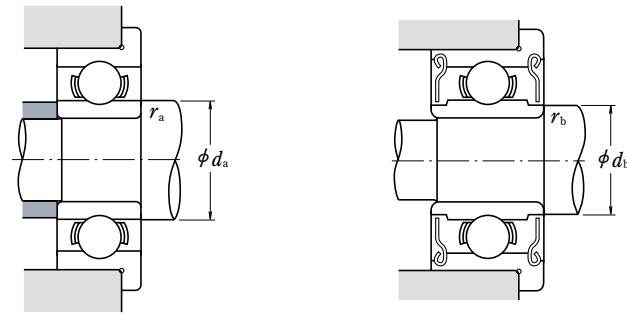
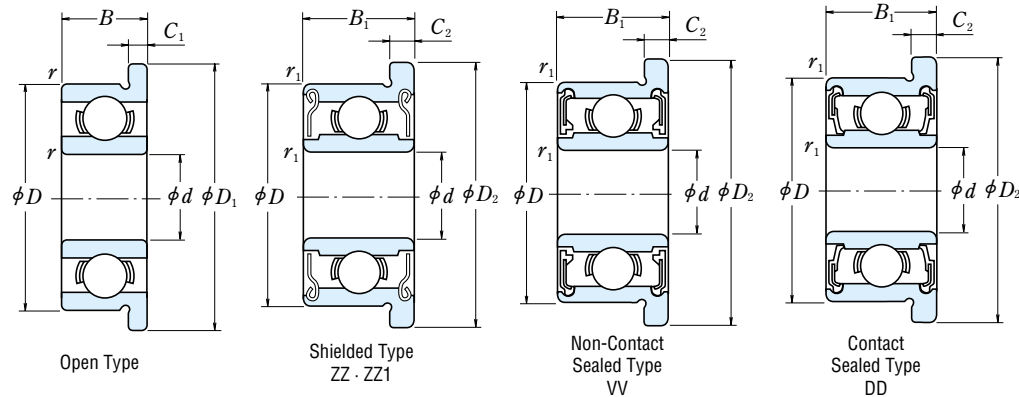

d	Boundary Dimensions (mm)								Basic Load Ratings (N) (kgf)				Limiting Speeds (rpm)			
	D	D <sub>1</sub>	D <sub>2</sub>	B	B <sub>1</sub>	C <sub>1</sub>	C <sub>2</sub>	r <sub>min</sub>	r <sub>1 min</sub>	C <sub>r</sub>	C <sub>0r</sub>	C <sub>r</sub>	C <sub>0r</sub>	Open Grease Z · ZZ V · VV	D · DD	Open Oil Z
5	8	9.2	—	2	—	0.6	—	0.1	—	310	120	31	12	53 000	—	63 000
	8	—	9.2	—	2.5	—	0.6	—	0.1	278	131	28	13	53 000	—	63 000
	9	10.2	10.2	2.5	3	0.6	0.6	0.15	0.15	430	168	44	17	50 000	—	60 000
	10	11.2	11.6	3	4	0.6	0.8	0.15	0.15	430	168	44	17	50 000	—	60 000
11	12.5	12.5	3	5	0.8	1	0.15	0.15	—	715	281	73	29	45 000	—	53 000
	13	15	15	4	4	1	1	0.2	0.2	1 080	430	110	44	43 000	40 000	50 000
	14	16	16	5	5	1	1	0.2	0.2	1 330	505	135	52	40 000	38 000	50 000
	16	18	18	5	5	1	1	0.3	0.3	1 730	670	177	68	36 000	32 000	43 000
19	22	22	6	6	1.5	1.5	0.3	0.3	—	2 340	885	238	90	32 000	30 000	40 000
	22	25	25	6	7	1.5	1.5	0.3	0.3	3 300	1 370	335	140	30 000	28 000	36 000
6	10	11.2	11.2	2.5	3	0.6	0.6	0.15	0.1	495	218	51	22	45 000	—	53 000
	12	13.2	13.6	3	4	0.6	0.8	0.2	0.15	715	292	73	30	43 000	40 000	50 000
	13	15	15	3.5	5	1	1.1	0.15	0.15	1 080	440	110	45	40 000	38 000	50 000
	15	17	17	5	5	1.2	1.2	0.2	0.2	1 730	670	177	68	40 000	36 000	45 000
17	19	19	6	6	1.2	1.2	0.3	0.3	—	2 260	835	231	85	38 000	34 000	45 000
	19	22	22	6	6	1.5	1.5	0.3	0.3	2 340	885	238	90	32 000	30 000	40 000
	22	25	25	7	7	1.5	1.5	0.3	0.3	3 300	1 370	335	140	30 000	28 000	36 000
	22	25	25	7	7	1.5	1.5	0.3	0.3	3 300	1 370	335	140	30 000	28 000	36 000
7	11	12.2	12.2	2.5	3	0.6	0.6	0.15	0.1	455	201	47	21	43 000	—	50 000
	13	14.2	14.6	3	4	0.6	0.8	0.2	0.15	540	276	55	28	40 000	—	48 000
	14	16	16	3.5	5	1	1.1	0.15	0.15	1 170	510	120	52	40 000	34 000	45 000
	17	19	19	5	5	1.2	1.2	0.3	0.3	1 610	715	164	73	36 000	28 000	43 000
19	22	22	6	6	1.5	1.5	0.3	0.3	—	2 340	885	238	90	36 000	32 000	43 000
	22	25	25	7	7	1.5	1.5	0.3	0.3	3 300	1 370	335	140	30 000	28 000	36 000
8	12	13.2	13.6	2.5	3.5	0.6	0.8	0.15	0.1	545	274	56	28	40 000	—	48 000
	14	15.6	15.6	3.5	4	0.8	0.8	0.2	0.15	820	385	83	39	38 000	32 000	45 000
	16	18	18	4	5	1	1.1	0.2	0.2	1 610	710	164	73	36 000	30 000	43 000
	19	22	22	6	6	1.5	1.5	0.3	0.3	2 240	910	228	93	36 000	28 000	43 000
22	25	25	7	7	1.5	1.5	0.3	0.3	—	3 300	1 370	335	140	34 000	28 000	40 000
	25	25	7	7	1.5	1.5	0.3	0.3	3 300	1 370	335	140	34 000	28 000	40 000	
9	17	19	19	4	5	1	1.1	0.2	0.2	1 330	665	136	68	36 000	24 000	43 000
	20	23	23	6	6	1.5	1.5	0.3	0.3	1 720	840	175	86	34 000	24 000	40 000

Bearing Numbers				Abutment and Fillet Dimensions (mm)				Mass (g)	
Open	Shielded	Sealed		d <sub>a min</sub>	d <sub>b max</sub>	r <sub>a max</sub>	r <sub>b max</sub>	Open	Shielded
MF 85	—	—	—	5.8	—	0.1	—	0.33	—
—	MF 85 ZZ	—	—	—	5.8	—	0.1	—	0.41
MF 95	MF 95 ZZ1	—	—	6.2	6.0	0.15	0.15	0.59	0.66
MF 105	MF 105 ZZ	—	—	6.2	6.0	0.15	0.15	1.05	1.46
F 685	F 685 ZZ	—	—	6.2	6.2	0.15	0.15	1.37	2.18
F 695	F 695 ZZ	VV	DD	6.6	6.6	0.2	0.2	2.79	2.84
F 605	F 605 ZZ	—	DD	6.6	6.9	0.2	0.2	3.9	3.85
F 625	F 625 ZZ1	VV	DD	7.0	7.5	0.3	0.3	5.37	5.27
F 635	F 635 ZZ1	VV	DD	7.0	8.5	0.3	0.3	9.49	9.49
MF 106	MF 106 ZZ1	—	—	7.2	7.0	0.15	0.1	0.65	0.77
MF 126	MF 126 ZZ	—	DD	7.6	7.2	0.2	0.15	1.38	1.94
F 686 A	F 686 AZZ	VV	DD	7.2	7.4	0.15	0.15	2.25	3.04
F 696	F 696 ZZ1	VV	DD	7.6	7.9	0.2	0.2	4.34	4.26
F 606	F 606 ZZ	VV	DD	8.0	8.2	0.3	0.3	6.58	6.61
F 626	F 626 ZZ1	VV	DD	8.0	8.5	0.3	0.3	9.09	9.09
F 636	F 636 ZZ	VV	DD	8.0	10.5	0.3	0.3	14.6	14.7
MF 117	MF 117 ZZ	—	—	8.2	8.0	0.15	0.1	0.72	0.82
MF 137	MF 137 ZZ	—	—	8.6	9.0	0.2	0.15	1.7	2.23
F 687	F 687 ZZ1	VV	DD	8.2	8.5	0.15	0.15	2.48	3.37
F 697	F 697 ZZ1	VV	DD	9.0	10.2	0.3	0.3	5.65	5.65
F 607	F 607 ZZ1	VV	DD	9.0	9.1	0.3	0.3	8.66	8.66
F 627	F 627 ZZ	VV	DD	9.0	10.5	0.3	0.3	14.2	14.2
MF 128	MF 128 ZZ1	—	—	9.2	9.0	0.15	0.1	0.82	1.15
MF 148	MF 148 ZZ	VV	DD	9.6	9.2	0.2	0.15	2.09	2.39
F 688 A	F 688 AZZ	VV	DD	9.6	10.2	0.2	0.2	3.54	4.47
F 698	F 698 ZZ	VV	DD	10.0	10.0	0.3	0.3	8.35	8.3
F 608	F 608 ZZ	VV	DD	10.0	10.5	0.3	0.3	13.4	13.5
F 689	F 689 ZZ1	VV	DD	10.6	11.5	0.2	0.2	3.97	4.91
F 699	F 699 ZZ1	VV	DD	11.0	12.0	0.3	0.3	9.51	9.51

Remark 1. When using bearings with a rotating outer ring, please contact NSK if they are shielded.

Inch Design

Bore Diameter 1.016~9.525 mm

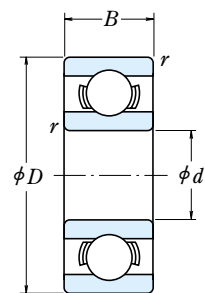

Open Type

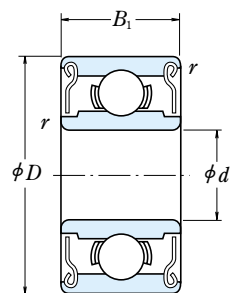

Shielded Type  
ZZ · ZJS

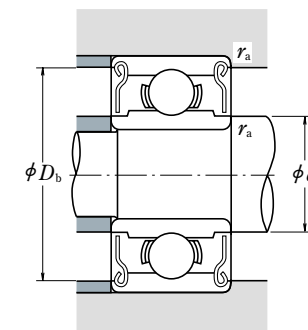
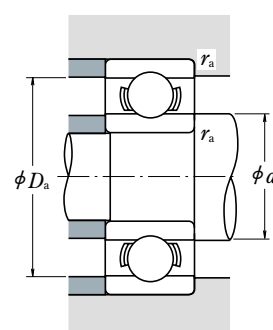

d	Boundary Dimensions (mm)				Basic Load Ratings (N)				Limiting Speeds (rpm)		Bearing Open
	D	B	B <sub>1</sub>	r <sub>min</sub>	C <sub>r</sub>	C <sub>0r</sub>	C <sub>r</sub>	C <sub>0r</sub>	Grease Open Z · ZZ	Oil Open Z	
1.016	3.175	1.191	—	0.1	80	23	8	2.5	130 000	150 000	R 09
1.191	3.967	1.588	2.380	0.1	138	35	14	3.5	110 000	130 000	R 0
1.397	4.762	1.984	2.779	0.1	231	66	24	6.5	90 000	110 000	R 1
1.984	6.350	2.380	3.571	0.1	310	108	32	11	67 000	80 000	R 1-4
2.380	4.762	1.588	—	0.1	188	60	19	6	80 000	95 000	R 133
	4.762	—	2.380	0.1	143	52	15	5.5	80 000	95 000	—
	7.938	2.779	3.571	0.15	550	175	56	18	60 000	71 000	R 1-5
3.175	6.350	2.380	2.779	0.1	283	95	29	9.5	67 000	80 000	R 144
	7.938	2.779	3.571	0.1	560	179	57	18	60 000	67 000	R 2-5
	9.525	2.779	3.571	0.15	640	225	65	23	53 000	63 000	R 2-6
3.967	9.525	3.967	3.967	0.3	630	218	64	22	56 000	67 000	R 2
	12.700	4.366	4.366	0.3	640	225	65	23	53 000	63 000	R 2A
	7.938	2.779	3.175	0.1	360	149	37	15	53 000	63 000	R 155
4.762	7.938	2.779	3.175	0.1	360	149	37	15	53 000	63 000	R 156
	9.525	3.175	3.175	0.1	710	270	73	28	50 000	60 000	R 166
	12.700	3.967	4.978	0.3	1 300	485	133	49	43 000	53 000	R 3
6.350	9.525	3.175	3.175	0.1	420	204	43	21	48 000	56 000	R 168B
	12.700	3.175	4.762	0.15	1 080	440	110	45	40 000	50 000	R 188
	15.875	4.978	4.978	0.3	1 610	660	164	68	38 000	45 000	R 4B
7.938	19.050	5.558	7.142	0.4	2 620	1 060	267	108	36 000	43 000	R 4AA
	12.700	3.967	3.967	0.15	540	276	55	28	40 000	48 000	R 1810
9.525	22.225	5.558	7.142	0.4	3 350	1 410	340	144	32 000	38 000	R 6

Numbers	Abutment and Fillet Dimensions (mm)					Mass (g)		
	Shielded	d <sub>a</sub> min	d <sub>b</sub> max	D <sub>a</sub> max	D <sub>b</sub> min	r <sub>a</sub> max	Open	approx Shielded
—	—	1.9	—	2.3	—	0.1	0.04	—
R 0 ZZ	—	2.0	1.9	3.1	3.5	0.1	0.09	0.11
R 1 ZZ	—	2.2	2.3	3.9	4.1	0.1	0.15	0.19
R 1-4 ZZ	—	2.8	3.9	5.5	5.9	0.1	0.35	0.50
—	—	3.2	—	3.9	—	0.1	0.10	—
R 133 ZZS	—	—	3.0	—	4.2	0.1	—	0.13
R 1-5 ZZ	—	3.6	4.1	6.7	7.0	0.15	0.60	0.72
R 144 ZZ	—	4.0	3.9	5.5	5.9	0.1	0.25	0.27
R 2-5 ZZ	—	4.0	4.3	7.1	7.3	0.1	0.55	0.72
R 2-6 ZZS	—	4.4	4.6	8.3	8.2	0.15	0.96	1.13
R 2 ZZ	—	5.2	4.8	7.5	8.0	0.3	1.36	1.39
R 2A ZZ	—	5.2	4.6	10.7	8.2	0.3	3.3	3.23
R 155 ZZS	—	4.8	5.5	7.1	7.3	0.1	0.51	0.56
R 156 ZZS	—	5.6	5.5	7.1	7.3	0.1	0.39	0.42
R 166 ZZ	—	5.6	5.9	8.7	8.8	0.1	0.81	0.85
R 3 ZZ	—	6.8	6.5	10.7	11.2	0.3	2.21	2.79
R 168 BZZ	—	7.2	7.0	8.7	8.9	0.1	0.58	0.62
R 188 ZZ	—	7.6	7.4	11.5	11.6	0.15	1.53	2.21
R 4B ZZ	—	8.4	8.4	13.8	13.8	0.3	4.5	4.43
R 4AA ZZ	—	9.4	9.0	16.0	16.6	0.4	7.48	9.17
R 1810 ZZ	—	9.2	9.0	11.5	11.6	0.15	1.56	1.48
R 6 ZZ	—	12.6	11.9	19.2	20.0	0.4	9.02	11

- Remarks 1. When using bearings with a rotating outer ring, please contact NSK if they are shielded.  
2. Bearings with double shields (ZZ, ZJS) are also available with single shields (Z, ZS).

Inch Design With Flange

Bore Diameter 1.191~9.525 mm

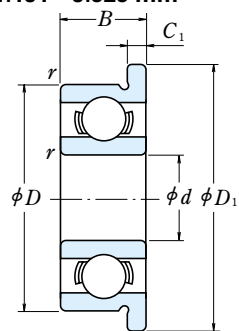

Open Type

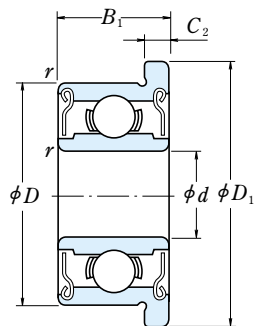

Shielded Type  
ZZ · ZS

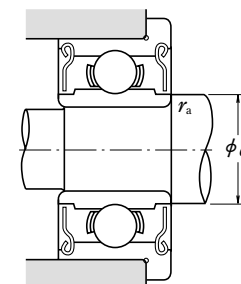
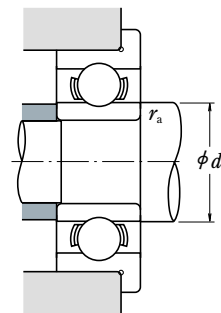

d	Boundary Dimensions (mm)							Basic Load Ratings (N) (kgf)			
	D	D <sub>1</sub>	B	B <sub>1</sub>	C <sub>1</sub>	C <sub>2</sub>	r <sub>min</sub>	C <sub>r</sub>	C <sub>0r</sub>	C <sub>r</sub>	C <sub>0r</sub>
1.191	3.967	5.156	1.588	2.380	0.330	0.790	0.1	138	35	14	3.5
1.397	4.762	5.944	1.984	2.779	0.580	0.790	0.1	231	66	24	6.5
1.984	6.350	7.518	2.380	3.571	0.580	0.790	0.1	310	108	32	11
2.380	4.762	5.944	1.588	—	0.460	—	0.1	188	60	19	6
	4.762	5.944	—	2.380	—	0.790	0.1	143	52	15	5.5
	7.938	9.119	2.779	3.571	0.580	0.790	0.15	550	175	56	18
3.175	6.350	7.518	2.380	2.779	0.580	0.790	0.1	283	95	29	9.5
	7.938	9.119	2.779	3.571	0.580	0.790	0.1	560	179	57	18
	9.525	10.719	2.779	3.571	0.580	0.790	0.15	640	225	65	23
	9.525	11.176	3.967	3.967	0.760	0.760	0.3	630	218	64	22
3.967	7.938	9.119	2.779	3.175	0.580	0.910	0.1	360	149	37	15
4.762	7.938	9.119	2.779	3.175	0.580	0.910	0.1	360	149	37	15
	9.525	10.719	3.175	3.175	0.580	0.790	0.1	710	270	73	28
	12.700	14.351	4.978	4.978	1.070	1.070	0.3	1 300	485	133	49
6.350	9.525	10.719	3.175	3.175	0.580	0.910	0.1	420	204	43	21
	12.700	13.894	3.175	4.762	0.580	1.140	0.15	1 080	440	110	45
	15.875	17.526	4.978	4.978	1.070	1.070	0.3	1 610	660	164	68
7.938	12.700	13.894	3.967	3.967	0.790	0.790	0.15	540	276	55	28
9.525	22.225	24.613	7.142	7.142	1.570	1.570	0.4	3 350	1 410	340	144

Limiting Speeds (rpm)		Bearing Numbers		Abutment and Fillet Dimensions (mm)			Mass (g)	
Grease Open Z · ZZ	Oil Open Z	Open	Shielded	d <sub>a</sub> min	d <sub>b</sub> max	r <sub>a</sub> max	Open	approx Shielded
110 000	130 000	FR 0	FR 0 ZZ	2.0	1.9	0.1	0.11	0.16
90 000	110 000	FR 1	FR 1 ZZ	2.2	2.3	0.1	0.20	0.25
67 000	80 000	FR 1-4	FR 1-4 ZZ	2.8	3.9	0.1	0.41	0.58
80 000	95 000	FR 133	—	3.2	—	0.1	0.13	—
80 000	95 000	—	FR 133 ZS	—	3.0	0.1	—	0.19
60 000	71 000	FR 1-5	FR 1-5 ZZ	3.6	4.1	0.15	0.68	0.82
67 000	80 000	FR 144	FR 144 ZZ	4.0	3.9	0.1	0.31	0.35
60 000	67 000	FR 2-5	FR 2-5 ZZ	4.0	4.3	0.1	0.62	0.81
53 000	63 000	FR 2-6	FR 2-6 ZS	4.4	4.6	0.15	1.04	1.25
56 000	67 000	FR 2	FR 2 ZZ	5.2	4.8	0.3	1.51	1.55
53 000	63 000	FR 155	FR 155 ZS	4.8	5.5	0.1	0.59	0.67
53 000	63 000	FR 156	FR 156 ZS	5.6	5.5	0.1	0.47	0.53
50 000	60 000	FR 166	FR 166 ZZ	5.6	5.9	0.1	0.90	0.98
43 000	53 000	FR 3	FR 3 ZZ	6.8	6.5	0.3	2.97	3.09
48 000	56 000	FR 168B	FR 168 BZZ	7.2	7.0	0.1	0.66	0.75
40 000	50 000	FR 188	FR 188 ZZ	7.6	7.4	0.15	1.64	2.49
38 000	45 000	FR 4B	FR 4B ZZ	8.4	8.4	0.3	4.78	4.78
40 000	48 000	FR 1810	FR 1810 ZZ	9.2	9.0	0.15	1.71	1.63
32 000	38 000	FR 6	FR 6 ZZ	12.6	11.9	0.4	10.1	12.1

- Remarks 1. When using bearings with a rotating outer ring, please contact NSK if they are shielded.  
2. Bearings with double shields (ZZ, ZS) are also available with single shields (Z, ZS).



## ANGULAR CONTACT BALL BEARINGS

### SINGLE-ROW AND MATCHED ANGULAR CONTACT BALL BEARINGS

Bore Diameter 10~ 50mm.....Pages B50~B55  
 Bore Diameter 60~120mm.....Pages B56~B61  
 Bore Diameter 130~200mm.....Pages B62~B65

### DOUBLE-ROW ANGULAR CONTACT BALL BEARINGS

Bore Diameter 10~ 85mm.....Pages B66~B67

### FOUR-POINT CONTACT BALL BEARINGS

Bore Diameter 30~200mm.....Pages B68~B71



## DESIGN, TYPES, AND FEATURES

### SINGLE-ROW ANGULAR CONTACT BALL BEARINGS

Since these bearings have a contact angle, they can sustain significant axial loads in one direction together with radial loads. Because of their design, when a radial load is applied, an axial force component is produced; therefore, two opposed bearings or a combination of more than two must be used.

Since the rigidity of single-row angular contact ball bearings can be increased by preloading, they are often used in the main spindles of machine tools, for which high running accuracy is required. (Refer to Chapter 10, Preload, Page A96).

Usually, the cages for angular contact ball bearings with a contact angle of 30° (Symbol **A**) or 40° (Symbol **B**) are in accordance with Table 1, but depending on the application, machined synthetic resin cages or molded polyamide resin cages are also used. The basic load ratings given in the bearing tables are based on the cage classification listed in Table 1.

Though the figures in the bearing tables (Pages B50 to B61; bearing bore diameters of 10 to 120) show bearings with single-shoulder-type inner rings, both-shoulder-type bearings are also available. Please consult NSK for more detailed information.

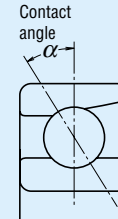

**Table 1 Standard Cages for Angular Contact Ball Bearings**

Series	Pressed Steel Cages	Machined Brass Cages
79A5, C	—	7900~7940
70A	7000~7018	7019~7040
70C	—	7000~7022
72A, B	7200~7222	7224~7240
72C	—	7200~7240
73A, B	7300~7320	7321~7340

In addition, for bearings with the same serial number, if the type of cages are different, the number of balls may also be different. In such a case, the load rating will differ from the one listed in the bearing tables.

Angular Contact Ball Bearings with contact angles of 15° (Symbol **C**) and 25° (Symbol **A5**) are primarily for high precision or high speed applications, and machined brass or synthetic resin cages or molded polyamide cages are used.

The maximum operating temperature of molded polyamide cages is 120°C.

## MATCHED ANGULAR CONTACT BALL BEARINGS

The types and features of matched angular contact ball bearings are shown in Table 2.

Table 2 Types and Features of Matched Angular Contact Ball Bearings

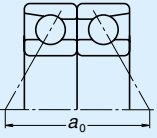
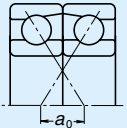
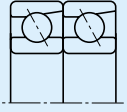
Figure	Arrangement	Features
	Back-to-back (DB) (Example) 7208 A DB	Radial loads and axial loads in both directions can be sustained. Since the distance between the effective load centers $a_0$ is big, this type is suitable if moments are applied.
	Face-to-face (DF) (Example) 7208 B DF	Radial loads and axial loads in both directions can be sustained. Compared with the DB Type, the distance between the effective load centers is small, so the capacity to sustain moments is inferior to the DB Type.
	Tandem (DT) (Example) 7208 A DT	Radial loads and axial loads in one direction can be sustained. Since two bearings share the axial load, this arrangement is used when the load in one direction is heavy.

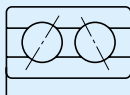

### DOUBLE-ROW ANGULAR CONTACT BALL BEARINGS

This is basically a back-to-back mounting of two single-row angular contact ball bearings, but their inner and outer rings are each integrated into one. Axial loads in both directions can be sustained, and the capacity to sustain moments is good. This type is used as fixed-end bearings.

Their cages are pressed steel.

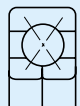

### FOUR-POINT CONTACT BALL BEARINGS

The inner ring is split radially into two pieces. Their design allows one bearing to sustain significant axial loads in either direction.

The contact angle is  $35^\circ$ , so the axial load capacity is high. This type is suitable for carrying pure axial loads or combined loads where the axial loads are high.

The cages are made of machined brass.

## PRECAUTIONS FOR USE OF ANGULAR CONTACT BALL BEARINGS

Under severe operating conditions where the speed and temperature are close to their limits, lubrication is marginal, vibration and moment loads are heavy, they may not be suitable, particularly for certain types of cages. In such a case, please consult with NSK beforehand.

And if the load on angular contact ball bearings becomes too small, or if the ratio of the axial and radial loads for matched bearings exceeds ' $e$ ' ( $e$  is listed in the bearings tables) during operation, slippage occurs between the balls and raceways, which may result in smearing. Especially with large bearings since the weight of the balls and cage is high. If such load conditions are expected, please consult with NSK for selection of the bearings.

## TOLERANCES AND RUNNING ACCURACY

### SINGLE-ROW ANGULAR CONTACT

**BALL BEARINGS** .....Table 8.2 (Pages A60–A63)

### MATCHED ANGULAR CONTACT

**BALL BEARINGS** .....Table 8.2 (Pages A60–A63)

### DOUBLE-ROW ANGULAR CONTACT

**BALL BEARINGS** .....Table 8.2 (Pages A60–A63)

### FOUR-POINT CONTACT BALL

**BEARINGS** .....Table 8.2 (Pages A60–A63)

## RECOMMENDED FITS

### SINGLE-ROW ANGULAR CONTACT BALL

**BEARINGS** .....Table 9.2 (Page A84)

Table 9.4 (Page A85)

### MATCHED ANGULAR CONTACT BALL

**BEARINGS** .....Table 9.2 (Page A84)

Table 9.4 (Page A85)

### DOUBLE-ROW ANGULAR CONTACT BALL

**BEARINGS** .....Table 9.2 (Page A84)

Table 9.4 (Page A85)

**FOUR-POINT CONTACT BALL BEARINGS** .....Table 9.2 (Page A84)

Table 9.4 (Page A85)

## INTERNAL CLEARANCES

**MATCHED ANGULAR CONTACT BALL BEARINGS** .....Table 9.17 (Page A94)

Matched angular contact ball bearings with precision better than P5 are primarily used in the main spindles of machine tools, so they are used with a preload for rigidity. For convenience of selection, internal clearances are adjusted to produce Very Light, Light, Medium, and Heavy Preloads. Their fitting is also special. Concerning these matters, please refer to Tables 10.1 and 10.2 (Pages A98 and A99).

The clearance (or preload) of matched bearings is obtained by axially tightening a pair of bearings till the side faces of their inner or outer rings are pressed against each other.

### DOUBLE-ROW ANGULAR CONTACT BALL BEARINGS

For the clearance in double-row angular contact ball bearings, please consult with NSK.

**FOUR-POINT CONTACT BALL BEARINGS** .....Table 9.18 (Page A94)

## LIMITING SPEEDS

In cases of single-row and matched angular contact ball bearings, the Limiting speeds listed in the bearing table are for bearings with machined cage. For those with pressed cages, the listed speeds must be reduced by 20%.

The limiting speeds of bearings with contact angles of  $15^\circ$  (Symbol **C**) and  $25^\circ$  (Symbol **A5**) are for bearings with precision of P5 and better (with machined synthetic-resin cages or molded polyamide cages).

The limiting speeds listed in the bearing tables should be adjusted depending on the bearing load conditions. Also, higher speeds are attainable by making changes in the lubrication method, cage design, etc. Refer to Page A37 for detailed information.

SINGLE/MATCHED MOUNTINGS

Bore Diameter 10~17 mm

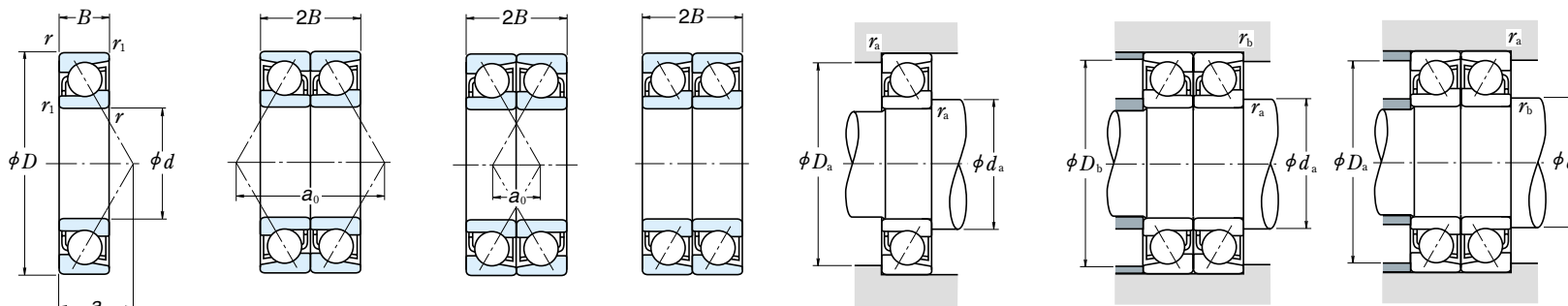

Single Back-to-Back DB Front-to-Front DF Tandem DT

Boundary Dimensions (mm)	Basic Load Ratings (Single) (N)				Factor $f_0$	Limiting Speeds (1) (rpm)		Eff. Load Centers (mm) $a$	Abutment and Fillet Dimensions (mm)			Mass (kg) approx				
	$d$	$D$	$B$	$r_{1\ min}$		$C_r$	$C_{0r}$		Grease	Oil	$d_a\ min$		$D_a\ max$	$r_a\ max$		
10	22	6	0.3	0.15	2 880	1 450	294	148	—	40 000	56 000	6.7	12.5	19.5	0.3	0.009
	22	6	0.3	0.15	3 000	1 520	305	155	14.1	48 000	63 000	5.1	12.5	19.5	0.3	0.009
	26	8	0.3	0.15	5 350	2 600	550	266	—	32 000	43 000	9.2	12.5	23.5	0.3	0.019
	26	8	0.3	0.15	5 300	2 490	540	254	12.6	45 000	63 000	6.4	12.5	23.5	0.3	0.021
	30	9	0.6	0.3	5 400	2 710	555	276	—	28 000	38 000	10.3	15	25	0.6	0.032
	30	9	0.6	0.3	5 000	2 500	510	255	—	20 000	28 000	12.9	15	25	0.6	0.032
	30	9	0.6	0.3	5 400	2 610	550	266	13.2	40 000	56 000	7.2	15	25	0.6	0.036
	35	11	0.6	0.3	9 300	4 300	950	440	—	20 000	26 000	12.0	15	30	0.6	0.053
	35	11	0.6	0.3	8 750	4 050	890	410	—	18 000	24 000	14.9	15	30	0.6	0.054
12	24	6	0.3	0.15	3 200	1 770	325	181	—	38 000	53 000	7.2	14.5	21.5	0.3	0.011
	24	6	0.3	0.15	3 350	1 860	340	189	14.7	45 000	63 000	5.4	14.5	21.5	0.3	0.011
	28	8	0.3	0.15	5 800	2 980	590	305	—	28 000	38 000	9.8	14.5	25.5	0.3	0.021
	28	8	0.3	0.15	5 800	2 900	590	296	13.2	40 000	56 000	6.7	14.5	25.5	0.3	0.024
	32	10	0.6	0.3	8 000	4 050	815	410	—	26 000	34 000	11.4	17	27	0.6	0.037
	32	10	0.6	0.3	7 450	3 750	760	380	—	18 000	26 000	14.2	17	27	0.6	0.038
	32	10	0.6	0.3	7 900	3 850	805	395	12.5	36 000	50 000	7.9	17	27	0.6	0.041
	37	12	1	0.6	9 450	4 500	965	460	—	18 000	24 000	13.1	18	31	1	0.060
	37	12	1	0.6	8 850	4 200	900	425	—	16 000	22 000	16.3	18	31	1	0.062
15	28	7	0.3	0.15	4 550	2 530	465	258	—	32 000	43 000	8.5	17.5	25.5	0.3	0.015
	28	7	0.3	0.15	4 750	2 640	485	270	14.5	38 000	53 000	6.4	17.5	25.5	0.3	0.015
	32	9	0.3	0.15	6 100	3 450	625	350	—	24 000	32 000	11.3	17.5	29.5	0.3	0.030
	32	9	0.3	0.15	6 250	3 400	635	345	14.1	34 000	48 000	7.6	17.5	29.5	0.3	0.034
	35	11	0.6	0.3	8 650	4 650	880	475	—	22 000	30 000	12.7	20	30	0.6	0.045
	35	11	0.6	0.3	7 950	4 300	810	440	—	16 000	22 000	16.0	20	30	0.6	0.046
	35	11	0.6	0.3	8 650	4 550	885	460	13.2	32 000	45 000	8.8	20	30	0.6	0.052
	42	13	1	0.6	13 400	7 100	1 370	720	—	16 000	22 000	14.7	21	36	1	0.084
	42	13	1	0.6	12 500	6 600	1 270	670	—	14 000	19 000	18.5	21	36	1	0.086
17	30	7	0.3	0.15	4 750	2 800	485	286	—	30 000	40 000	9.0	19.5	27.5	0.3	0.017
	30	7	0.3	0.15	5 000	2 940	510	299	14.8	34 000	48 000	6.6	19.5	27.5	0.3	0.017
	35	10	0.3	0.15	6 400	3 800	655	390	—	22 000	30 000	12.5	19.5	32.5	0.3	0.040
	35	10	0.3	0.15	6 600	3 800	675	390	14.5	32 000	43 000	8.5	19.5	32.5	0.3	0.044
	40	12	0.6	0.3	10 800	6 000	1 100	610	—	20 000	28 000	14.2	22	35	0.6	0.067
	40	12	0.6	0.3	9 950	5 500	1 010	565	—	14 000	19 000	18.0	22	35	0.6	0.068
	40	12	0.6	0.3	10 900	5 850	1 110	595	13.3	28 000	38 000	9.8	22	35	0.6	0.075
	47	14	1	0.6	15 900	8 650	1 630	880	—	14 000	19 000	16.2	23	41	1	0.116
	47	14	1	0.6	14 800	8 000	1 510	820	—	13 000	17 000	20.4	23	41	1	0.118

Notes (1) For applications operating near the limiting speed, refer to Page B49.  
(2) The suffixes A, A5, B, and C represent contact angles of 30°, 25°, 40°, and 15° respectively.

Dynamic Equivalent Load  $P = XF_r + YF_a$

Contact Angle	$i f_0 F_a^*$ $C_{0r}$	$e$	Single, DT				DB or DF				
			$F_a/F_r \leq e$		$F_a/F_r > e$		$F_a/F_r \leq e$		$F_a/F_r > e$		
			X	Y	X	Y	X	Y	X	Y	
15°	0.178	0.38	1	0	0.44	1.47	1	1.65	0.72	2.39	
	0.357	0.40	1	0	0.44	1.40	1	1.57	0.72	2.28	
	0.714	0.43	1	0	0.44	1.30	1	1.46	0.72	2.11	
	1.07	0.46	1	0	0.44	1.23	1	1.38	0.72	2.00	
	1.43	0.47	1	0	0.44	1.19	1	1.34	0.72	1.93	
	2.14	0.50	1	0	0.44	1.12	1	1.26	0.72	1.82	
	3.57	0.55	1	0	0.44	1.02	1	1.14	0.72	1.66	
	5.35	0.56	1	0	0.44	1.00	1	1.12	0.72	1.63	
	25°	—	0.68	1	0	0.41	0.87	1	0.92	0.67	1.41
	30°	—	0.80	1	0	0.39	0.76	1	0.78	0.63	1.24
40°	—	1.14	1	0	0.35	0.57	1	0.55	0.57	0.93	

\*For  $i$ , use 2 for DB, DF and 1 for DT

Static Equivalent Load  $P_0 = X_0 F_r + Y_0 F_a$

Contact Angle	Single, DT		DB or DF		Single or DT mounting When $F_r > 0.5 F_r + Y_0 F_a$ use $P_0 = F_r$
	$X_0$	$Y_0$	$X_0$	$Y_0$	
15°	0.5	0.46	1	0.92	
25°	0.5	0.38	1	0.76	
30°	0.5	0.33	1	0.66	
40°	0.5	0.26	1	0.52	

Bearing Numbers (°)	Basic Load Ratings (Matched) (N)				Limiting Speeds (1) (Matched) (rpm)		Load Center Spacings (mm)		Abutment and Fillet Dimensions (mm)				
	Single	Duplex	$C_r$	$C_{0r}$	Grease	Oil	DB	DF	$d_b$ (3) min	$D_b$ max	$r_b$ (3) max		
7900 A5 DB DF DT			4 700	2 900	475	296	13.5	1.5	—	20.8	0.15		
7900 C DB DF DT			4 900	3 050	500	310	10.3	1.7	—	20.8	0.15		
7000 A DB DF DT			8 750	5 200	890	530	18.4	2.4	11.2	24.8	0.15		
7000 C DB DF DT			8 650	5 000	880	510	12.8	3.2	—	24.8	0.15		
7200 A DB DF DT			8 800	5 400	900	555	20.5	2.5	12.5	27.5	0.3		
7200 B DB DF DT			8 100	5 000	825	510	16.000	22 000	25.8	7.8	12.5	27.5	0.3
7200 C DB DF DT			8 800	5 200	895	530	32 000	45 000	14.4	3.6	—	27.5	0.3
7300 A DB DF DT			15 100	8 600	1 540	880	16 000	22 000	24.0	2.0	12.5	32.5	0.3
7300 B DB DF DT			14 200	8 100	1 450	825	14 000	20 000	29.9	7.9	12.5	32.5	0.3
7901 A5 DB DF DT			5 200	3 550	530	360	30 000	43 000	14.4	2.4	—	22.8	0.15
7901 C DB DF DT			5 450	3 700	555	380	36 000	50 000	10.8	1.2	—	22.8	0.15
7001 A DB DF DT			9 400	5 950	955	610	22 000	30 000	19.5	3.5	13.2	26.8	0.15
7001 C DB DF DT			9 400	5 800	960	590	32 000	45 000	13.4	2.6	—	26.8	0.15
7201 A DB DF DT			13 000	8 050	1 330	820	20 000	28 000	22.7	2.7	14.5	29.5	0.3
7201 B DB DF DT			12 100	7 500	1 230	765	15 000	20 000	28.5	8.5	14.5	29.5	0.3
7201 C DB DF DT			12 800	7 700	1 310	785	30 000	40 000	15.9	4.1	—	29.5	0.3
7301 A DB DF DT			15 400	9 000	1 570	915	15 000	20 000	26.1	2.1	17	32	0.6
7301 B DB DF DT			14 400	8 400	1 460	855	13 000	18 000	32.6	8.6	17	32	0.6
7902 A5 DB DF DT			7 400	5 050	755	515	26 000	34 000	17.0	3.0	—	26.8	0.15
7902 C DB DF DT			7 750	5 300	790	540	30 000	43 000	12.8	1.2	—	26.8	0.15
7002 A DB DF DT			9 950	6 850	1 010	700	19 000	26 000	22.6	4.6	16.2	30.8	0.15
7002 C DB DF DT			10 100	6 750	1 030	690	28 000	38 000	15.3	2.7	—	30.8	0.15
7202 A DB DF DT			14 000	9 300	1 430	950	18 000	24 000	25.4	3.4	17.5	32.5	0.3
7202 B DB DF DT			12 900	8 600	1 310	875	13 000	18 000	32.0	10.0	17.5	32.5	0.3
7202 C DB DF DT			14 100	9 050	1 440	925	26 000	36 000	17.7	4.3	—	32	

SINGLE/MATCHED MOUNTINGS

Bore Diameter 20~35 mm

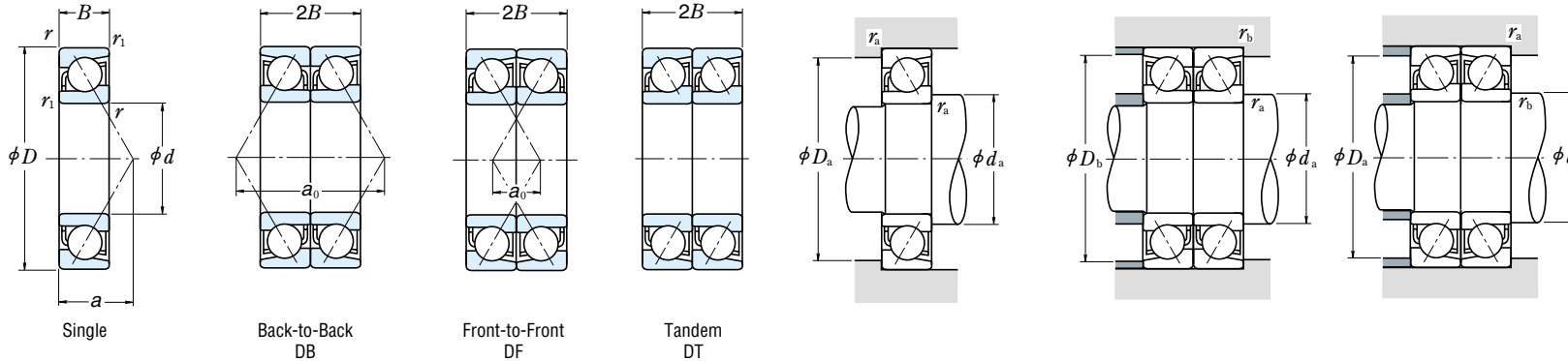

Boundary Dimensions (mm)	Basic Load Ratings (Single) (N)				Factor $f_0$	Limiting Speeds (1) (rpm)		Eff. Load Centers (mm) $a$	Abutment and Fillet Dimensions (mm)			Mass (kg) approx				
	$d$	$D$	$B$	$r_{1 \min}$		$C_r$	$C_{0r}$		Grease	Oil	$d_a \min$		$D_a \max$	$r_a \max$		
20	37	9	0.3	0.15	6 600	4 050	675	410	—	24 000	32 000	11.1	22.5	34.5	0.3	0.036
	37	9	0.3	0.15	6 950	4 250	710	430	14.9	28 000	38 000	8.3	22.5	34.5	0.3	0.036
	42	12	0.6	0.3	10 800	6 600	1 110	670	—	18 000	24 000	14.9	25	37	0.6	0.068
	42	12	0.6	0.3	11 100	6 550	1 130	665	14.0	26 000	36 000	10.1	25	37	0.6	0.076
	47	14	1	0.6	14 500	8 300	1 480	845	—	17 000	22 000	16.7	26	41	1	0.106
	47	14	1	0.6	13 300	7 650	1 360	780	—	12 000	16 000	21.1	26	41	1	0.109
	47	14	1	0.6	14 600	8 050	1 480	825	13.3	24 000	34 000	11.5	26	41	1	0.118
	52	15	1.1	0.6	18 700	10 400	1 910	1 060	—	13 000	17 000	17.9	27	45	1	0.146
	52	15	1.1	0.6	17 300	9 650	1 770	985	—	11 000	15 000	22.6	27	45	1	0.15
	25	42	9	0.3	0.15	7 450	5 150	760	525	—	20 000	28 000	12.3	27.5	39.5	0.3
42		9	0.3	0.15	7 850	5 400	800	555	15.5	24 000	34 000	9.0	27.5	39.5	0.3	0.042
47		12	0.6	0.3	11 300	7 400	1 150	750	—	16 000	22 000	16.4	30	42	0.6	0.079
47		12	0.6	0.3	11 700	7 400	1 190	755	14.7	22 000	30 000	10.8	30	42	0.6	0.089
52		15	1	0.6	16 200	10 300	1 650	1 050	—	15 000	20 000	18.6	31	46	1	0.13
52		15	1	0.6	14 800	9 400	1 510	960	—	10 000	14 000	23.7	31	46	1	0.133
52		15	1	0.6	16 600	10 200	1 690	1 040	14.0	22 000	28 000	12.7	31	46	1	0.143
62		17	1.1	0.6	26 400	15 800	2 690	1 610	—	10 000	14 000	21.1	32	55	1	0.235
62		17	1.1	0.6	24 400	14 600	2 490	1 490	—	9 000	13 000	26.7	32	55	1	0.241
30		47	9	0.3	0.15	7 850	5 950	800	605	—	18 000	24 000	13.5	32.5	44.5	0.3
	47	9	0.3	0.15	8 300	6 250	845	640	15.9	22 000	28 000	9.7	32.5	44.5	0.3	0.049
	55	13	1	0.6	14 500	10 100	1 480	1 030	—	13 000	18 000	18.8	36	49	1	0.116
	55	13	1	0.6	15 100	10 300	1 540	1 050	14.9	19 000	26 000	12.2	36	49	1	0.134
	62	16	1	0.6	22 500	14 800	2 300	1 510	—	12 000	17 000	21.3	36	56	1	0.197
	62	16	1	0.6	20 500	13 500	2 090	1 380	—	8 500	12 000	27.3	36	56	1	0.202
	62	16	1	0.6	23 000	14 700	2 350	1 500	13.9	18 000	24 000	14.2	36	56	1	0.222
	72	19	1.1	0.6	33 500	20 900	3 450	2 130	—	9 000	12 000	24.2	37	65	1	0.346
	72	19	1.1	0.6	31 000	19 300	3 150	1 960	—	8 000	11 000	30.9	37	65	1	0.354
	35	55	10	0.6	0.3	11 400	8 700	1 170	885	—	15 000	20 000	15.5	40	50	0.6
55		10	0.6	0.3	12 100	9 150	1 230	930	15.7	18 000	24 000	11.0	40	50	0.6	0.074
62		14	1	0.6	18 300	13 400	1 870	1 370	—	12 000	16 000	21.0	41	56	1	0.153
62		14	1	0.6	19 100	13 700	1 950	1 390	15.0	17 000	22 000	13.5	41	56	1	0.173
72		17	1.1	0.6	29 700	20 100	3 050	2 050	—	10 000	14 000	23.9	42	65	1	0.287
72		17	1.1	0.6	27 100	18 400	2 760	1 870	—	7 500	10 000	30.9	42	65	1	0.294
72		17	1.1	0.6	30 500	19 900	3 100	2 030	13.9	15 000	20 000	15.7	42	65	1	0.32
80		21	1.5	1	40 000	26 300	4 050	2 680	—	8 000	10 000	27.1	44	71	1.5	0.464
80		21	1.5	1	36 500	24 200	3 750	2 460	—	7 100	9 500	34.6	44	71	1.5	0.474

Notes (1) For applications operating near the limiting speed, refer to Page B49.  
(2) The suffixes A, A5, B, and C represent contact angles of 30°, 25°, 40°, and 15° respectively.

Dynamic Equivalent Load  $P = X F_r + Y F_a$

Contact Angle	$i f_0 F_a^*$ $C_{0r}$	$e$	Single, DT				DB or DF				
			$F_a/F_r \leq e$		$F_a/F_r > e$		$F_a/F_r \leq e$		$F_a/F_r > e$		
			X	Y	X	Y	X	Y	X	Y	
15°	0.178	0.38	1	0	0.44	1.47	1	1.65	0.72	2.39	
	0.357	0.40	1	0	0.44	1.40	1	1.57	0.72	2.28	
	0.714	0.43	1	0	0.44	1.30	1	1.46	0.72	2.11	
	1.07	0.46	1	0	0.44	1.23	1	1.38	0.72	2.00	
	1.43	0.47	1	0	0.44	1.19	1	1.34	0.72	1.93	
	2.14	0.50	1	0	0.44	1.12	1	1.26	0.72	1.82	
	3.57	0.55	1	0	0.44	1.02	1	1.14	0.72	1.66	
	5.35	0.56	1	0	0.44	1.00	1	1.12	0.72	1.63	
	25°	—	0.68	1	0	0.41	0.87	1	0.92	0.67	1.41
	30°	—	0.80	1	0	0.39	0.76	1	0.78	0.63	1.24
40°	—	1.14	1	0	0.35	0.57	1	0.55	0.57	0.93	

\*For  $i$ , use 2 for DB, DF and 1 for DT

Static Equivalent Load  $P_0 = X_0 F_r + Y_0 F_a$

Contact Angle	Single, DT		DB or DF		Single or DT mounting When $F_r > 0.5 F_r + Y_0 F_a$ use $P_0 = F_r$
	$X_0$	$Y_0$	$X_0$	$Y_0$	
15°	0.5	0.46	1	0.92	
25°	0.5	0.38	1	0.76	
30°	0.5	0.33	1	0.66	
40°	0.5	0.26	1	0.52	

Bearing Numbers (°)	Basic Load Ratings (Matched) (N)				Limiting Speeds (1) (Matched) (rpm)		Load Center Spacings (mm)		Abutment and Fillet Dimensions (mm)				
	Single	Duplex	$C_r$	$C_{0r}$	Grease	Oil	DB	DF	$d_b$ (3) min	$D_b$ max	$r_b$ (3) max		
<b>7904 A5 DB DF DT</b>			10 700	8 100	1 090	825	19 000	26 000	22.3	4.3	—	35.8	0.15
<b>7904 C DB DF DT</b>			11 300	8 500	1 150	865	22 000	32 000	16.6	1.4	—	35.8	0.15
<b>7004 A DB DF DT</b>			17 600	13 200	1 800	1 340	15 000	20 000	29.9	5.9	22.5	39.5	0.3
<b>7004 C DB DF DT</b>			18 000	13 100	1 840	1 330	20 000	30 000	20.3	3.7	—	39.5	0.3
<b>7204 A DB DF DT</b>			23 500	16 600	2 400	1 690	13 000	19 000	33.3	5.3	25	42	0.6
<b>7204 B DB DF DT</b>			21 600	15 300	2 210	1 560	9 500	13 000	42.1	14.1	25	42	0.6
<b>7204 C DB DF DT</b>			23 600	16 100	2 410	1 650	19 000	26 000	23.0	5.0	—	42	0.6
<b>7304 A DB DF DT</b>			30 500	20 800	3 100	2 130	10 000	13 000	35.8	5.8	25	47	0.6
<b>7304 B DB DF DT</b>			28 200	19 300	2 870	1 970	9 000	12 000	45.2	15.2	25	47	0.6
<b>7905 A5 DB DF DT</b>			12 100	10 300	1 230	1 050	16 000	22 000	24.6	6.6	—	40.8	0.15
<b>7905 C DB DF DT</b>			12 700	10 800	1 300	1 110	19 000	26 000	18.0	0.0	—	40.8	0.15
<b>7005 A DB DF DT</b>			18 300	14 800	1 870	1 510	13 000	17 000	32.8	8.8	27.5	44.5	0.3
<b>7005 C DB DF DT</b>			19 000	14 800	1 940	1 510	18 000	26 000	21.6	2.4	—	44.5	0.3
<b>7205 A DB DF DT</b>			26 300	20 500	2 690	2 090	12 000	16 000	37.2	7.2	30	47	0.6
<b>7205 B DB DF DT</b>			24 000	18 800	2 450	1 920	8 500	11 000	47.3	17.3	30	47	0.6
<b>7205 C DB DF DT</b>			27 000	20 400	2 750	2 080	17 000	24 000	25.3	4.7	—	47	0.6
<b>7305 A DB DF DT</b>			43 000	31 500	4 400	3 250	8 500	11 000	42.1	8.1	30	57	0.6
<b>7305 B DB DF DT</b>			39 500	29 300	4 050	2 980	7 500	10 000	53.5	19.5	30	57	0.6
<b>7906 A5 DB DF DT</b>			12 800	11 900	1 300	1 210	14 000	19 000	27.0	9.0	—	45.8	0.15
<b>7906 C DB DF DT</b>			13 500	12 500	1 380	1 280	17 000	24 000	19.3	1.3	—	45.8	0.15
<b>7006 A DB DF DT</b>			23 600	20 200	2 410	2 060	11 000	15 000	37.5	11.5	35	50	0.6
<b>7006 C DB DF DT</b>			24 600	20 500	2 510	2 090	15 000	22 000	24.4	1.6	—	50	0.6
<b>7206 A DB DF DT</b>			36 500	29 500	3 750	3 000	10 000	13 000	42.6	10.6	35	57	0.6
<b>7206 B DB DF DT</b>			33 500	27 000	3 400	2 760	7 100	9 500	54.6	22.6	35	57	0.6
<b>7206 C DB</b>													

SINGLE/MATCHED MOUNTINGS

Bore Diameter 40~55 mm

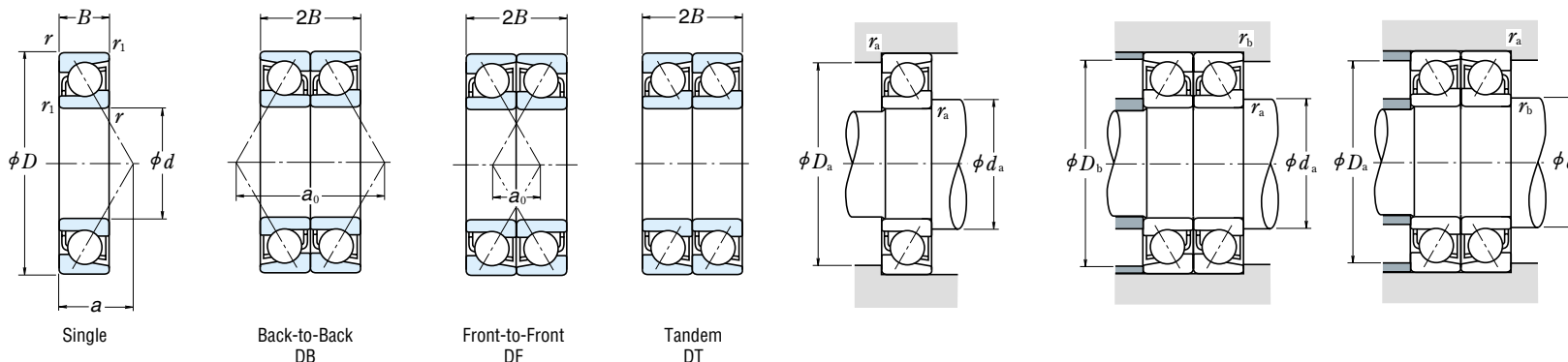

Dynamic Equivalent Load  $P = XF_r + YF_a$

Contact Angle	$i f_0 F_a^*$ $C_{0r}$	e	Single, DT				DB or DF			
			$F_a/F_r \leq e$		$F_a/F_r > e$		$F_a/F_r \leq e$		$F_a/F_r > e$	
			X	Y	X	Y	X	Y	X	Y
15°	0.178	0.38	1	0	0.44	1.47	1	1.65	0.72	2.39
	0.357	0.40	1	0	0.44	1.40	1	1.57	0.72	2.28
	0.714	0.43	1	0	0.44	1.30	1	1.46	0.72	2.11
	1.07	0.46	1	0	0.44	1.23	1	1.38	0.72	2.00
	1.43	0.47	1	0	0.44	1.19	1	1.34	0.72	1.93
	2.14	0.50	1	0	0.44	1.12	1	1.26	0.72	1.82
	3.57	0.55	1	0	0.44	1.02	1	1.14	0.72	1.66
	5.35	0.56	1	0	0.44	1.00	1	1.12	0.72	1.63
25°	—	0.68	1	0	0.41	0.87	1	0.92	0.67	1.41
30°	—	0.80	1	0	0.39	0.76	1	0.78	0.63	1.24
40°	—	1.14	1	0	0.35	0.57	1	0.55	0.57	0.93

\*For i, use 2 for DB, DF and 1 for DT

Static Equivalent Load  $P_0 = X_0 F_r + Y_0 F_a$

Contact Angle	Single, DT		DB or DF		Single or DT mounting When $F_r > 0.5 F_r + Y_0 F_a$ use $P_0 = F_r$
	$X_0$	$Y_0$	$X_0$	$Y_0$	
15°	0.5	0.46	1	0.92	
25°	0.5	0.38	1	0.76	
30°	0.5	0.33	1	0.66	
40°	0.5	0.26	1	0.52	

	Boundary Dimensions (mm)					Basic Load Ratings (Single) (N)				Factor $f_0$	Limiting Speeds (1) (rpm)		Eff. Load Centers (mm) a	Abutment and Fillet Dimensions (mm)			Mass (kg) approx
	d	D	B	r <sub>min</sub>	r <sub>1 min</sub>	C <sub>r</sub>	C <sub>0r</sub>	C <sub>r</sub>	C <sub>0r</sub>		Grease	Oil		d <sub>a min</sub>	D <sub>a max</sub>	r <sub>a max</sub>	
40	62	12	0.6	0.3	0.3	14 300	11 200	1 460	1 140	—	14 000	18 000	17.9	45	57	0.6	0.11
	62	12	0.6	0.3	0.3	15 100	11 700	1 540	1 200	15.7	16 000	22 000	12.8	45	57	0.6	0.109
	68	15	1	0.6	0.6	19 500	15 400	1 990	1 570	—	10 000	14 000	23.1	46	62	1	0.19
	68	15	1	0.6	0.6	20 600	15 900	2 100	1 620	15.4	15 000	20 000	14.7	46	62	1	0.213
	80	18	1.1	0.6	0.6	35 500	25 100	3 600	2 560	—	9 500	13 000	26.3	47	73	1	0.375
	80	18	1.1	0.6	0.6	32 000	23 000	3 250	2 340	—	6 700	9 000	34.2	47	73	1	0.383
	80	18	1.1	0.6	0.6	36 500	25 200	3 700	2 570	14.1	14 000	19 000	17.0	47	73	1	0.418
	90	23	1.5	1	1	49 000	33 000	5 000	3 350	—	7 100	9 000	30.3	49	81	1.5	0.633
	90	23	1.5	1	1	45 000	30 500	4 550	3 100	—	6 300	8 500	38.8	49	81	1.5	0.648
	45	68	12	0.6	0.3	0.3	15 100	12 700	1 540	1 290	—	12 000	17 000	19.2	50	63	0.6
68		12	0.6	0.3	0.3	16 000	13 400	1 630	1 360	16.0	14 000	20 000	13.6	50	63	0.6	0.129
75		16	1	0.6	0.6	23 100	18 700	2 360	1 910	—	9 500	13 000	25.3	51	69	1	0.25
75		16	1	0.6	0.6	24 400	19 300	2 490	1 960	15.4	14 000	19 000	16.0	51	69	1	0.274
85		19	1.1	0.6	0.6	39 500	28 700	4 050	2 930	—	8 500	12 000	28.3	52	78	1	0.411
85		19	1.1	0.6	0.6	36 000	26 200	3 650	2 680	—	6 300	8 500	36.8	52	78	1	0.421
85		19	1.1	0.6	0.6	41 000	28 800	4 150	2 940	14.2	12 000	17 000	18.2	52	78	1	0.468
100		25	1.5	1	1	63 500	43 500	6 450	4 450	—	6 300	8 500	33.4	54	91	1.5	0.848
100		25	1.5	1	1	58 500	40 000	5 950	4 100	—	5 600	7 500	42.9	54	91	1.5	0.869
50		72	12	0.6	0.3	0.3	15 900	14 200	1 630	1 450	—	11 000	15 000	20.2	55	67	0.6
	72	12	0.6	0.3	0.3	16 900	15 000	1 720	1 530	16.2	13 000	18 000	14.2	55	67	0.6	0.13
	80	16	1	0.6	0.6	24 500	21 100	2 500	2 150	—	8 500	12 000	26.8	56	74	1	0.263
	80	16	1	0.6	0.6	26 000	21 900	2 650	2 230	15.7	12 000	17 000	16.7	56	74	1	0.293
	90	20	1.1	0.6	0.6	41 500	31 500	4 200	3 200	—	8 000	11 000	30.2	57	83	1	0.466
	90	20	1.1	0.6	0.6	37 500	28 600	3 800	2 920	—	5 600	8 000	39.4	57	83	1	0.477
	90	20	1.1	0.6	0.6	43 000	31 500	4 350	3 250	14.5	12 000	16 000	19.4	57	83	1	0.528
	110	27	2	1	1	74 000	52 000	7 550	5 300	—	5 600	7 500	36.6	60	100	2	1.1
	110	27	2	1	1	68 000	48 000	6 950	4 900	—	5 000	6 700	47.1	60	100	2	1.12
	55	80	13	1	0.6	0.6	18 100	16 800	1 840	1 710	—	10 000	14 000	22.2	61	74	1
80		13	1	0.6	0.6	19 100	17 700	1 950	1 810	16.3	12 000	16 000	15.5	61	74	1	0.182
90		18	1.1	0.6	0.6	32 500	27 700	3 300	2 830	—	7 500	11 000	29.9	62	83	1	0.391
90		18	1.1	0.6	0.6	34 000	28 600	3 500	2 920	15.5	11 000	15 000	18.7	62	83	1	0.43
100		21	1.5	1	1	51 000	39 500	5 200	4 050	—	7 100	10 000	32.9	64	91	1.5	0.613
100		21	1.5	1	1	46 500	36 000	4 700	3 700	—	5 300	7 100	43.0	64	91	1.5	0.627
100		21	1.5	1	1	53 000	40 000	5 400	4 100	14.5	10 000	14 000	20.9	64	91	1.5	0.688
120		29	2	1	1	86 000	61 500	8 750	6 250	—	5 000	6 700	39.8	65	110	2	1.41
120		29	2	1	1	79 000	56 500	8 050	5 750	—	4 500	6 300	51.2	65	110	2	1.45

Notes (1) For applications operating near the limiting speed, refer to Page B49.  
(2) The suffixes A, A5, B, and C represent contact angles of 30°, 25°, 40°, and 15° respectively.

Bearing Numbers (°)	Basic Load Ratings (Matched) (N)				Limiting Speeds (1) (Matched) (rpm)		Load Center Spacings (mm)		Abutment and Fillet Dimensions (mm)				
	Single	Duplex	C <sub>r</sub>	C <sub>0r</sub>	Grease	Oil	DB	DF	d <sub>b</sub> (2) min	D <sub>b</sub> max	r <sub>b</sub> (2) max		
7908 A5 DB DF DT			23 300	22 300	2 370	2 270	11 000	15 000	35.8	11.8	—	59.5	0.3
7908 C DB DF DT			24 600	23 500	2 510	2 390	13 000	18 000	25.7	1.7	—	59.5	0.3
7008 A DB DF DT			31 500	31 000	3 250	3 150	8 500	11 000	46.2	16.2	45	63	0.6
7008 C DB DF DT			33 500	32 000	3 400	3 250	12 000	17 000	29.5	0.5	—	63	0.6
7208 A DB DF DT			57 500	50 500	5 850	5 150	7 500	10 000	52.6	16.6	45	75	0.6
7208 B DB DF DT			52 000	46 000	5 300	4 700	5 300	7 500	68.3	32.3	45	75	0.6
7208 C DB DF DT			59 000	50 500	6 000	5 150	11 000	15 000	34.1	1.9	—	75	0.6
7308 A DB DF DT			79 500	66 000	8 100	6 700	5 600	7 500	60.5	14.5	46	84	1
7308 B DB DF DT			73 000	60 500	7 400	6 200	5 000	6 700	77.5	31.5	46	84	1
7909 A5 DB DF DT			24 600	25 400	2 510	2 590	9 500	13 000	38.4	14.4	—	65.5	0.3
7909 C DB DF DT			26 000	26 800	2 660	2 730	12 000	16 000	27.1	3.1	—	65.5	0.3
7009 A DB DF DT			37 500	37 500	3 850	3 800	7 500	10 000	50.6	18.6	50	70	0.6
7009 C DB DF DT			39 500	38 500	4 050	3 950	11 000	15 000	32.1	0.1	—	70	0.6
7209 A DB DF DT			64 500	57 500	6 550	5 850	7 100	9 500	56.5	18.5	50	80	0.6
7209 B DB DF DT			58 500	52 500	5 950	5 350	5 000	6 700	73.5	35.5	50	80	0.6
7209 C DB DF DT			66 500	57 500	6 750	5 850	10 000	14 000	36.4	1.6	—	80	0.6
7309 A DB DF DT			103 000	87 000	10 500	8 900	5 000	6 700	66.9	16.9	51	94	1
7309 B DB DF DT			95 000	80 500	9 650	8 200	4 500	6 000	85.8	35.8	51	94	1
7910 A5 DB DF DT			25 900	28 400	2 640	2 900	9 000	12 000	40.5	16.5	—	69.5	0.3
7910 C DB DF DT			27 400	30 000	2 800	3 050	11 000	15 000	28.3	4.3	—	69.5	0.3
7010 A DB DF DT			40 000	42 000	4 050	4 300	7 100	9 500	53.5	21.5	55	75	0.6
7010 C DB DF DT			42 000	44 000	4 300	4 450	10 000	14 000	33.4	1.4	—	75	0.6
7210 A DB DF DT			67 000	63 000	6 850								



SINGLE/MATCHED MOUNTINGS

Bore Diameter 60~75 mm

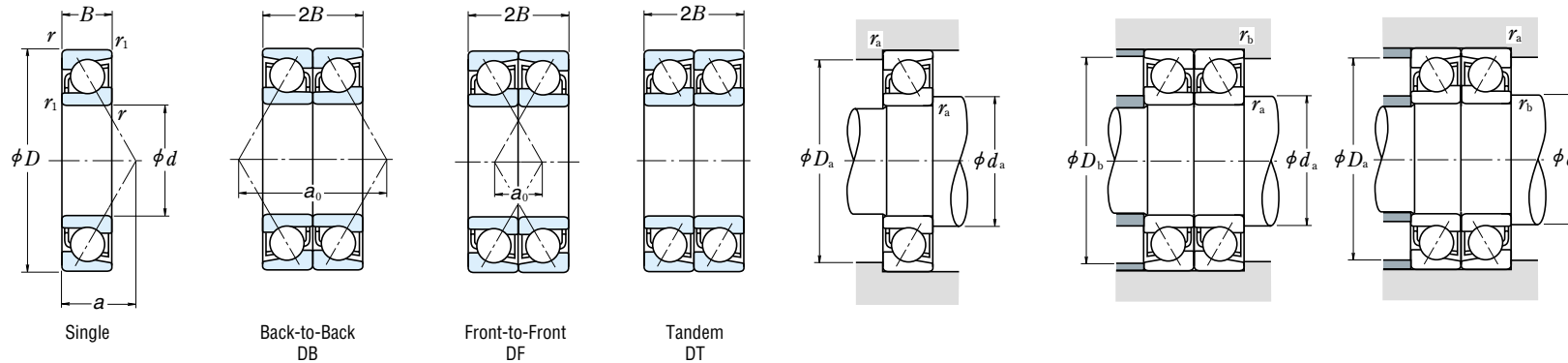

**Dynamic Equivalent Load**  $P = X F_r + Y F_a$

Contact Angle	$i f_0 F_a^*$ $C_{0r}$	$e$	Single, DT				DB or DF			
			$F_a/F_r \leq e$		$F_a/F_r > e$		$F_a/F_r \leq e$		$F_a/F_r > e$	
			X	Y	X	Y	X	Y	X	Y
15°	0.178	0.38	1	0	0.44	1.47	1	1.65	0.72	2.39
	0.357	0.40	1	0	0.44	1.40	1	1.57	0.72	2.28
	0.714	0.43	1	0	0.44	1.30	1	1.46	0.72	2.11
	1.07	0.46	1	0	0.44	1.23	1	1.38	0.72	2.00
	1.43	0.47	1	0	0.44	1.19	1	1.34	0.72	1.93
	2.14	0.50	1	0	0.44	1.12	1	1.26	0.72	1.82
	3.57	0.55	1	0	0.44	1.02	1	1.14	0.72	1.66
	5.35	0.56	1	0	0.44	1.00	1	1.12	0.72	1.63
25°	—	0.68	1	0	0.41	0.87	1	0.92	0.67	1.41
30°	—	0.80	1	0	0.39	0.76	1	0.78	0.63	1.24
40°	—	1.14	1	0	0.35	0.57	1	0.55	0.57	0.93

\*For  $i$ , use 2 for DB, DF and 1 for DT

**Static Equivalent Load**  $P_0 = X_0 F_r + Y_0 F_a$

Contact Angle	Single, DT		DB or DF		Single or DT mounting When $F_r > 0.5 F_r + Y_0 F_a$ use $P_0 = F_r$
	$X_0$	$Y_0$	$X_0$	$Y_0$	
15°	0.5	0.46	1	0.92	
25°	0.5	0.38	1	0.76	
30°	0.5	0.33	1	0.66	
40°	0.5	0.26	1	0.52	

	Boundary Dimensions (mm)				Basic Load Ratings (Single) (N)				Factor $f_0$	Limiting Speeds (1) (rpm)		Eff. Load Centers (mm) $a$	Abutment and Fillet Dimensions (mm)			Mass (kg) approx
	$d$	$D$	$B$	$r_{1 \min}$	$C_r$	$C_{0r}$	$C_r$	$C_{0r}$		Grease	Oil		$d_{a \min}$	$D_{a \max}$	$r_{a \max}$	
60	85	13	1	0.6	18 300	17 700	1 870	1 810	—	9 500	13 000	23.4	66	79	1	0.197
	85	13	1	0.6	19 400	18 700	1 980	1 910	16.5	11 000	15 000	16.2	66	79	1	0.194
	95	18	1.1	0.6	33 000	29 500	3 350	3 000	—	7 100	10 000	31.4	67	88	1	0.417
	95	18	1.1	0.6	35 000	30 500	3 600	3 150	15.7	10 000	14 000	19.4	67	88	1	0.46
	110	22	1.5	1	62 000	48 500	6 300	4 950	—	6 700	9 000	35.5	69	101	1.5	0.798
	110	22	1.5	1	56 000	44 500	5 700	4 550	—	4 800	6 300	46.7	69	101	1.5	0.815
	110	22	1.5	1	64 000	49 000	6 550	5 000	14.4	9 500	13 000	22.4	69	101	1.5	0.889
	130	31	2.1	1.1	98 000	71 500	10 000	7 250	—	4 800	6 300	42.9	72	118	2	1.74
	130	31	2.1	1.1	90 000	65 500	9 200	6 700	—	4 300	5 600	55.4	72	118	2	1.78
	65	90	13	1	0.6	19 100	19 400	1 940	1 980	—	9 000	12 000	24.6	71	84	1
90		13	1	0.6	20 200	20 500	2 060	2 090	16.7	10 000	14 000	16.9	71	84	1	0.208
100		18	1.1	0.6	35 000	33 000	3 550	3 350	—	6 700	9 500	32.8	72	93	1	0.455
100		18	1.1	0.6	37 000	34 500	3 800	3 500	15.9	10 000	13 000	20.0	72	93	1	0.493
120		23	1.5	1	70 500	58 000	7 150	5 900	—	6 000	8 500	38.2	74	111	1.5	1.03
120		23	1.5	1	63 500	52 500	6 500	5 350	—	4 300	6 000	50.3	74	111	1.5	1.05
120		23	1.5	1	73 000	58 500	7 450	6 000	14.6	9 000	12 000	23.9	74	111	1.5	1.14
140		33	2.1	1.1	111 000	82 000	11 300	8 350	—	4 300	6 000	46.1	77	128	2	2.12
140		33	2.1	1.1	102 000	75 500	10 400	7 700	—	3 800	5 300	59.5	77	128	2	2.17
70		100	16	1	0.6	26 500	26 300	2 710	2 680	—	8 000	11 000	27.8	76	94	1
	100	16	1	0.6	28 100	27 800	2 870	2 830	16.4	9 500	13 000	19.4	76	94	1	0.338
	110	20	1.1	0.6	44 000	41 500	4 500	4 200	—	6 300	8 500	36.0	77	103	1	0.625
	110	20	1.1	0.6	47 000	43 000	4 800	4 400	15.7	9 000	12 000	22.1	77	103	1	0.698
	125	24	1.5	1	76 500	63 500	7 800	6 500	—	5 600	8 000	40.1	79	116	1.5	1.11
	125	24	1.5	1	69 000	58 000	7 050	5 900	—	4 000	5 600	52.9	79	116	1.5	1.14
	125	24	1.5	1	79 500	64 500	8 100	6 600	14.6	8 500	11 000	25.1	79	116	1.5	1.24
	150	35	2.1	1.1	125 000	93 500	12 700	9 550	—	4 000	5 300	49.3	82	138	2	2.6
	150	35	2.1	1.1	114 000	86 000	11 700	8 750	—	3 600	5 000	63.6	82	138	2	2.65
	75	105	16	1	0.6	26 900	27 700	2 750	2 820	—	7 500	10 000	29.0	81	99	1
105		16	1	0.6	28 600	29 300	2 910	2 980	16.6	9 000	12 000	20.1	81	99	1	0.357
115		20	1.1	0.6	45 000	43 500	4 600	4 450	—	6 000	8 000	37.4	82	108	1	0.661
115		20	1.1	0.6	48 000	45 500	4 900	4 650	15.9	8 500	12 000	22.7	82	108	1	0.748
130		25	1.5	1	76 000	64 500	7 750	6 550	—	5 600	7 500	42.1	84	121	1.5	1.19
130		25	1.5	1	68 500	58 500	7 000	5 950	—	3 800	5 300	55.5	84	121	1.5	1.22
130		25	1.5	1	83 000	70 000	8 450	7 100	14.8	8 000	11 000	26.2	84	121	1.5	1.36
160		37	2.1	1.1	136 000	106 000	13 800	10 800	—	3 800	5 000	52.4	87	148	2	3.13
160		37	2.1	1.1	125 000	97 500	12 700	9 900	—	3 400	4 800	67.8	87	148	2	3.19

Notes (1) For applications operating near the limiting speed, refer to Page B49.  
(2) The suffixes A, A5, B, and C represent contact angles of 30°, 25°, 40°, and 15° respectively.

Bearing Numbers (°)	Basic Load Ratings (Matched) (N)				Limiting Speeds (1) (Matched) (rpm)		Load Center Spacings (mm)		Abutment and Fillet Dimensions (mm)		
	Single	Duplex	$C_r$	$C_{0r}$	Grease	Oil	DB	DF	$d_b$ (3) min	$D_b$ max	$r_b$ (3) max
7912 A5 DB DF DT	A5	DB	DF	DT	7 500	10 000	46.8	20.8	—	80	0.6
7912 C DB DF DT	C	DB	DF	DT	9 000	12 000	32.4	6.4	—	80	0.6
7012 A DB DF DT	A	DB	DF	DT	6 000	8 000	62.7	26.7	65	90	0.6
7012 C DB DF DT	C	DB	DF	DT	8 500	12 000	38.8	2.8	—	90	0.6
7212 A DB DF DT	A	DB	DF	DT	5 300	7 100	71.1	27.1	66	104	1
7212 B DB DF DT	B	DB	DF	DT	3 800	5 300	93.3	49.3	66	104	1
7212 C DB DF DT	C	DB	DF	DT	7 500	11 000	44.8	0.8	—	104	1
7312 A DB DF DT	A	DB	DF	DT	3 800	5 000	85.9	23.9	67	123	1
7312 B DB DF DT	B	DB	DF	DT	3 400	4 500	110.7	48.7	67	123	1
7913 A5 DB DF DT	A5	DB	DF	DT	7 100	9 500	49.1	23.1	—	85	0.6
7913 C DB DF DT	C	DB	DF	DT	8 500	12 000	33.8	7.8	—	85	0.6
7013 A DB DF DT	A	DB	DF	DT	5 600	7 500	65.6	29.6	70	95	0.6
7013 C DB DF DT	C	DB	DF	DT	8 000	11 000	40.1	4.1	—	95	0.6
7213 A DB DF DT	A	DB	DF	DT	4 800	6 700	76.4	30.4	71	114	1
7213 B DB DF DT	B	DB	DF	DT	3 400	4 800	100.6	54.6	71	114	1
7213 C DB DF DT	C	DB	DF	DT	7 100	9 500	47.8	1.8	—	114	1



SINGLE/MATCHED MOUNTINGS

Bore Diameter 80~95 mm

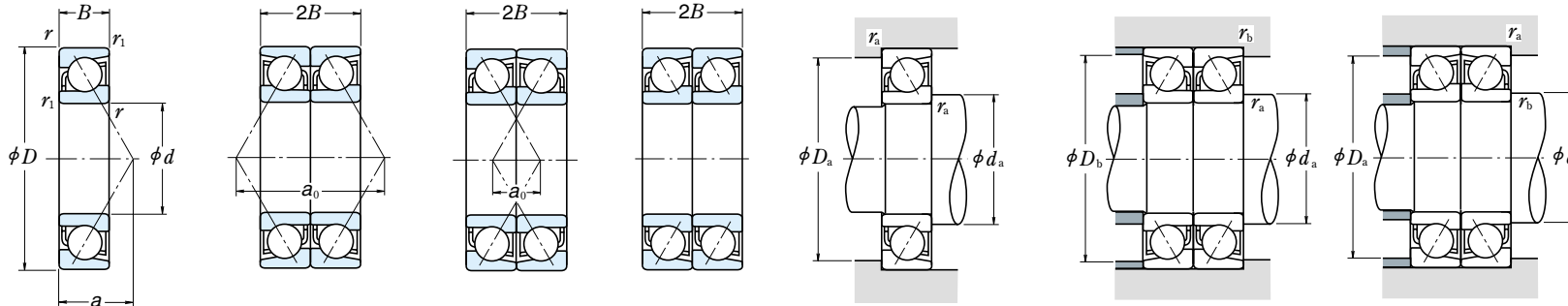

Dynamic Equivalent Load  $P = XF_r + YF_a$

Contact Angle	$i f_0 F_a^*$ $C_{0r}$	$e$	Single, DT				DB or DF				
			$F_a/F_r \leq e$		$F_a/F_r > e$		$F_a/F_r \leq e$		$F_a/F_r > e$		
			X	Y	X	Y	X	Y	X	Y	
15°	0.178	0.38	1	0	0.44	1.47	1	1.65	0.72	2.39	
	0.357	0.40	1	0	0.44	1.40	1	1.57	0.72	2.28	
	0.714	0.43	1	0	0.44	1.30	1	1.46	0.72	2.11	
	1.07	0.46	1	0	0.44	1.23	1	1.38	0.72	2.00	
	1.43	0.47	1	0	0.44	1.19	1	1.34	0.72	1.93	
	2.14	0.50	1	0	0.44	1.12	1	1.26	0.72	1.82	
	3.57	0.55	1	0	0.44	1.02	1	1.14	0.72	1.66	
	5.35	0.56	1	0	0.44	1.00	1	1.12	0.72	1.63	
	25°	—	0.68	1	0	0.41	0.87	1	0.92	0.67	1.41
	30°	—	0.80	1	0	0.39	0.76	1	0.78	0.63	1.24
40°	—	1.14	1	0	0.35	0.57	1	0.55	0.57	0.93	

\*For  $i$ , use 2 for DB, DF and 1 for DT

Static Equivalent Load  $P_0 = X_0 F_r + Y_0 F_a$

Contact Angle	Single, DT		DB or DF		Single or DT mounting When $F_r > 0.5 F_r + Y_0 F_a$ use $P_0 = F_r$
	$X_0$	$Y_0$	$X_0$	$Y_0$	
15°	0.5	0.46	1	0.92	
25°	0.5	0.38	1	0.76	
30°	0.5	0.33	1	0.66	
40°	0.5	0.26	1	0.52	

	Boundary Dimensions (mm)				Basic Load Ratings (Single) (N)				Factor $f_0$	Limiting Speeds (1) (rpm)		Eff. Load Centers (mm) $a$	Abutment and Fillet Dimensions (mm)			Mass (kg) approx	
	$d$	$D$	$B$	$r_{min}$ $r_{1min}$	$C_r$	$C_{0r}$	$C_r$	$C_{0r}$		$f_0$	Grease		Oil	$d_a$ min	$D_a$ max		$r_a$ max
80	110	16	1	0.6	27 300	29 000	2 790	2 960	—	7 100	10 000	30.2	86	104	1	0.38	
	110	16	1	0.6	29 000	30 500	2 960	3 150	16.7	8 500	12 000	20.7	86	104	1	0.376	
	125	22	1.1	0.6	55 000	53 000	5 650	5 400	—	5 600	7 500	40.6	87	118	1	0.88	
	125	22	1.1	0.6	58 500	55 500	6 000	5 650	15.7	8 000	11 000	24.7	87	118	1	0.966	
	140	26	2	1	89 000	76 000	9 100	7 750	—	5 000	7 100	44.8	90	130	2	1.46	
	140	26	2	1	80 500	69 500	8 200	7 050	—	3 600	5 000	59.1	90	130	2	1.49	
	140	26	2	1	93 000	77 500	9 450	7 900	14.7	7 500	10 000	27.7	90	130	2	1.63	
	170	39	2.1	1.1	147 000	119 000	15 000	12 100	—	3 600	4 800	55.6	92	158	2	3.71	
	170	39	2.1	1.1	135 000	109 000	13 800	11 100	—	3 200	4 300	71.9	92	158	2	3.79	
	85	120	18	1.1	0.6	36 500	38 500	3 750	3 900	—	6 700	9 000	32.9	92	113	1	0.541
120		18	1.1	0.6	39 000	40 500	3 950	4 150	16.5	8 000	11 000	22.7	92	113	1	0.534	
130		22	1.1	0.6	56 500	56 000	5 750	5 700	—	5 300	7 100	42.0	92	123	1	0.913	
130		22	1.1	0.6	60 000	58 500	6 150	6 000	15.9	7 500	10 000	25.4	92	123	1	1.01	
150		28	2	1	103 000	89 000	10 500	9 100	—	4 800	6 700	47.9	95	140	2	1.83	
150		28	2	1	93 000	81 000	9 500	8 250	—	3 400	4 800	63.3	95	140	2	1.87	
150		28	2	1	107 000	90 500	10 900	9 250	14.7	6 700	9 500	29.7	95	140	2	2.04	
180		41	3	1.1	159 000	133 000	16 200	13 500	—	3 400	4 500	58.8	99	166	2.5	4.33	
180		41	3	1.1	146 000	122 000	14 800	12 400	—	3 000	4 000	76.1	99	166	2.5	4.42	
90		125	18	1.1	0.6	39 500	43 500	4 000	4 450	—	6 300	8 500	34.1	97	118	1	0.56
	125	18	1.1	0.6	41 500	46 000	4 250	4 700	16.6	7 500	10 000	23.4	97	118	1	0.563	
	140	24	1.5	1	67 500	66 500	6 850	6 750	—	4 800	6 700	45.2	99	131	1.5	1.19	
	140	24	1.5	1	71 500	69 000	7 300	7 050	15.7	7 100	9 500	27.4	99	131	1.5	1.34	
	160	30	2	1	118 000	103 000	12 000	10 500	—	4 500	6 000	51.1	100	150	2	2.25	
	160	30	2	1	107 000	94 000	10 900	9 550	—	3 200	4 300	67.4	100	150	2	2.29	
	160	30	2	1	123 000	105 000	12 500	10 700	14.6	6 300	9 000	31.7	100	150	2	2.51	
	190	43	3	1.1	171 000	147 000	17 400	15 000	—	3 200	4 300	61.9	104	176	2.5	5.06	
	190	43	3	1.1	156 000	135 000	15 900	13 800	—	2 800	3 800	80.2	104	176	2.5	5.17	
	95	130	18	1.1	0.6	40 000	45 500	4 050	4 650	—	6 000	8 500	35.2	102	123	1	0.597
130		18	1.1	0.6	42 500	48 000	4 300	4 900	16.7	7 100	10 000	24.1	102	123	1	0.591	
145		24	1.5	1	67 000	67 000	6 800	6 800	—	4 500	6 300	46.6	104	136	1.5	1.43	
145		24	1.5	1	73 500	73 000	7 500	7 450	15.9	6 700	9 000	28.1	104	136	1.5	1.42	
170		32	2.1	1.1	128 000	111 000	13 000	11 300	—	4 300	5 600	54.2	107	158	2	2.68	
170		32	2.1	1.1	116 000	101 000	11 800	10 300	—	3 000	4 000	71.6	107	158	2	2.74	
170		32	2.1	1.1	133 000	112 000	13 500	11 400	14.6	6 000	8 500	33.7	107	158	2	3.05	
200		45	3	1.1	183 000	162 000	18 600	16 600	—	3 000	4 000	65.1	109	186	2.5	5.83	
200		45	3	1.1	167 000	149 000	17 100	15 200	—	2 600	3 600	84.3	109	186	2.5	5.98	

Notes (1) For applications operating near the limiting speed, refer to Page B49.  
(2) The suffixes A, A5, B, and C represent contact angles of 30°, 25°, 40°, and 15° respectively.

Bearing Numbers (°)	Basic Load Ratings (Matched) (N)				Limiting Speeds (1) (Matched) (rpm)		Load Center Spacings (mm)		Abutment and Fillet Dimensions (mm)		
	Single	Duplex	$C_r$	$C_{0r}$	Grease	Oil	DB	DF	$d_b$ (3) min	$D_b$ max	$r_b$ (3) max
7916 A5 DB DF DT	44 500	58 000	4 550	5 900	5 600	8 000	60.3	28.3	—	105	0.6
	47 000	61 500	4 800	6 250	6 700	9 500	41.5	9.5	—	105	0.6
	89 500	106 000	9 150	10 800	4 300	6 000	81.2	37.2	85	120	0.6
	95 500	111 000	9 700	11 300	6 300	9 000	49.4	5.4	—	120	0.6
	145 000	152 000	14 700	15 600	4 000	5 600	89.5	37.5	86	134	1
	131 000	139 000	13 300	14 100	2 800	4 000	118.3	66.3	86	134	1
	151 000	155 000	15 400	15 800	6 000	8 000	55.5	3.5	—	134	1
	239 000	238 000	24 400	24 200	2 800	3 800	111.2	33.2	87	163	1
	219 000	218 000	22 400	22 300	2 600	3 400	143.9	65.9	87	163	1
	59 500	77 000	6 100	7 850	5 300	7 500	65.8	29.8	—	115	0.6
63 000	81 500	6 450	8 300	6 300	9 000	45.5	9.5	—	115	0.6	
91 500	112 000	9 350	11 400	4 300	5 600	84.1	40.1	90	125	0.6	
98 000	117 000	9 950	12 000	6 000	8 500	50.8	6.8	—	125	0.6	
167 000	178 000	17 100	18 200	3 800	5 300	95.8	39.8	91	144	1	
151 000	162 000	15 400	16 500	2 800	3 800	126.6	70.6	91	144	1	
174 000	181 000	17 800	18 500	5 600	7 500	59.5	3.5	—	144	1	
258 000	265 000	26 300	27 000	2 600	3 600	117.5	35.5	92	173	1	
236 000	244 000	24 100	24 800	2 400	3 200	152.2	70.2	92	173	1	
64 000	87 000	6 500	8 900	5 000	7 100	68.1	32.1	—	120	0.6	
67 500	92 000	6 900	9 400	6 000	8 500	46.8	10.8	—	120	0.6	
109 000	133 000	11 200	13 500	3 800	5 300	90.4	42.4	96	134	1	
116 000	138 000	11 900	14 100	5 600	8 000	54.8	6.8	—	134	1	
191 000	206 000	19 500	21 000	3 600	5 000	102.2	42.2	96	154	1	
173 000	188 000	17 700	19 100	2 600	3 400	134.9	74.9	96	154	1	
199 000	209 000	20 300	21 400	5 300	7 100	63.5	3.5	—	154	1	
277 000	294 000	28 300	30 000	2 600	3 400	123.8	37.8	97	183	1	
254 000											

SINGLE/MATCHED MOUNTINGS

Bore Diameter 100~120 mm

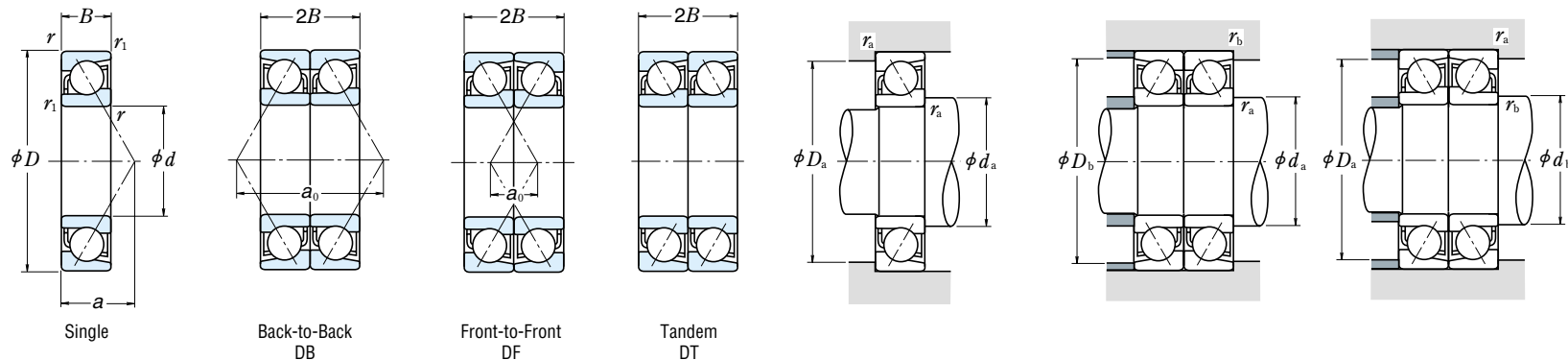

Dynamic Equivalent Load  $P = X F_r + Y F_a$

Contact Angle	$i f_0 F_a^*$ $C_{0r}$	e	Single, DT				DB or DF				
			$F_a/F_r \leq e$		$F_a/F_r > e$		$F_a/F_r \leq e$		$F_a/F_r > e$		
			X	Y	X	Y	X	Y	X	Y	
15°	0.178	0.38	1	0	0.44	1.47	1	1.65	0.72	2.39	
	0.357	0.40	1	0	0.44	1.40	1	1.57	0.72	2.28	
	0.714	0.43	1	0	0.44	1.30	1	1.46	0.72	2.11	
	1.07	0.46	1	0	0.44	1.23	1	1.38	0.72	2.00	
	1.43	0.47	1	0	0.44	1.19	1	1.34	0.72	1.93	
	2.14	0.50	1	0	0.44	1.12	1	1.26	0.72	1.82	
	3.57	0.55	1	0	0.44	1.02	1	1.14	0.72	1.66	
	5.35	0.56	1	0	0.44	1.00	1	1.12	0.72	1.63	
	25°	—	0.68	1	0	0.41	0.87	1	0.92	0.67	1.41
	30°	—	0.80	1	0	0.39	0.76	1	0.78	0.63	1.24
40°	—	1.14	1	0	0.35	0.57	1	0.55	0.57	0.93	

\*For  $i$ , use 2 for DB, DF and 1 for DT

Static Equivalent Load  $P_0 = X_0 F_r + Y_0 F_a$

Contact Angle	Single, DT		DB or DF		Single or DT mounting When $F_r > 0.5 F_r + Y_0 F_a$ use $P_0 = F_r$
	$X_0$	$Y_0$	$X_0$	$Y_0$	
15°	0.5	0.46	1	0.92	
25°	0.5	0.38	1	0.76	
30°	0.5	0.33	1	0.66	
40°	0.5	0.26	1	0.52	

	Boundary Dimensions (mm)				Basic Load Ratings (Single) (N)				Factor $f_0$	Limiting Speeds (1) (rpm)		Eff. Load Centers (mm) $a$	Abutment and Fillet Dimensions (mm)			Mass (kg) approx
	$d$	$D$	$B$	$r_{1 \min}$	$C_r$	$C_{0r}$	$C_r$	$C_{0r}$		Grease	Oil		$d_{a \min}$	$D_{a \max}$	$r_{a \max}$	
100	140	20	1.1	0.6	47 500	51 500	4 850	5 250	—	5 600	8 000	38.0	107	133	1	0.804
	140	20	1.1	0.6	50 000	54 000	5 100	5 550	16.5	6 700	9 000	26.1	107	133	1	0.794
	150	24	1.5	1	68 500	70 500	6 950	7 200	—	4 500	6 000	48.1	109	141	1.5	1.48
	150	24	1.5	1	75 500	77 000	7 700	7 900	16.0	6 300	9 000	28.7	109	141	1.5	1.46
	180	34	2.1	1.1	144 000	126 000	14 700	12 800	—	4 000	5 300	57.4	112	168	2	3.22
	180	34	2.1	1.1	130 000	114 000	13 300	11 700	—	2 800	3 800	75.7	112	168	2	3.28
	180	34	2.1	1.1	149 000	127 000	15 200	12 900	14.5	5 600	8 000	35.7	112	168	2	3.65
	215	47	3	1.1	207 000	193 000	21 100	19 700	—	2 800	3 800	69.0	114	201	2.5	7.29
	215	47	3	1.1	190 000	178 000	19 400	18 100	—	2 400	3 400	89.6	114	201	2.5	7.43
	105	145	20	1.1	0.6	48 000	54 000	4 900	5 500	—	5 600	7 500	39.2	112	138	1
145		20	1.1	0.6	51 000	57 000	5 200	5 800	16.6	6 300	9 000	26.7	112	138	1	0.826
160		26	2	1	80 000	81 500	8 150	8 350	—	4 300	5 600	51.2	115	150	2	1.84
160		26	2	1	88 000	89 500	9 000	9 100	15.9	6 000	8 500	30.7	115	150	2	1.82
190		36	2.1	1.1	157 000	142 000	16 000	14 400	—	3 800	5 000	60.6	117	178	2	3.84
190		36	2.1	1.1	142 000	129 000	14 500	13 100	—	2 600	3 600	79.9	117	178	2	3.92
190		36	2.1	1.1	162 000	143 000	16 600	14 600	14.5	5 300	7 500	37.7	117	178	2	4.33
225		49	3	1.1	208 000	193 000	21 200	19 700	—	2 600	3 600	72.1	119	211	2.5	9.34
225		49	3	1.1	191 000	177 000	19 400	18 100	—	2 400	3 200	93.7	119	211	2.5	9.43
110		150	20	1.1	0.6	49 000	56 000	5 000	5 750	—	5 300	7 100	40.3	117	143	1
	150	20	1.1	0.6	52 000	59 500	5 300	6 050	16.7	6 300	8 500	27.4	117	143	1	0.867
	170	28	2	1	96 500	95 500	9 850	9 700	—	4 000	5 300	54.4	120	160	2	2.28
	170	28	2	1	106 000	104 000	10 800	10 600	15.6	5 600	8 000	32.7	120	160	2	2.26
	200	38	2.1	1.1	170 000	158 000	17 300	16 100	—	3 600	4 800	63.7	122	188	2	4.49
	200	38	2.1	1.1	154 000	144 000	15 700	14 700	—	2 600	3 400	84.0	122	188	2	4.58
	200	38	2.1	1.1	176 000	160 000	17 900	16 300	14.5	5 000	7 100	39.8	122	188	2	5.1
	240	50	3	1.1	220 000	215 000	22 500	21 900	—	2 600	3 400	75.5	124	226	2.5	11.1
	240	50	3	1.1	201 000	197 000	20 500	20 100	—	2 200	3 000	98.4	124	226	2.5	11.2
	120	165	22	1.1	0.6	67 500	77 000	6 900	7 850	—	4 800	6 300	44.2	127	158	1
165		22	1.1	0.6	72 000	81 000	7 300	8 300	16.5	5 600	7 500	30.1	127	158	1	1.15
180		28	2	1	102 000	107 000	10 400	10 900	—	3 600	5 000	57.3	130	170	2	2.45
215		40	2.1	1.1	183 000	177 000	18 600	18 100	—	3 200	4 500	68.3	132	203	2	6.22
215		40	2.1	1.1	165 000	162 000	16 900	16 500	—	2 400	3 200	90.3	132	203	2	6.26
260		55	3	1.1	246 000	252 000	25 100	25 700	—	2 200	3 000	82.3	134	246	2.5	14.5
260		55	3	1.1	225 000	231 000	23 000	23 600	—	2 000	2 800	107.2	134	246	2.5	14.4

Notes (1) For applications operating near the limiting speed, refer to Page B49.  
(2) The suffixes A, A5, B, and C represent contact angles of 30°, 25°, 40°, and 15° respectively.

Bearing Numbers (°)	Basic Load Ratings (Matched) (N)				Limiting Speeds (1) (Matched) (rpm)		Load Center Spacings (mm)		Abutment and Fillet Dimensions (mm)		
	Single	Duplex	$C_r$	$C_{0r}$	Grease	Oil	DB	DF	$d_b^{(3)}$ min	$D_b$ max	$r_b^{(3)}$ max
7920 A5 DB DF DT			77 000	103 000	4 500	6 300	76.0	36.0	—	135	0.6
7920 C DB DF DT			81 500	108 000	5 300	7 500	52.2	12.2	—	135	0.6
7020 A DB DF DT			111 000	141 000	3 600	5 000	96.2	48.2	—	144	1
7020 C DB DF DT			122 000	154 000	5 300	7 100	57.5	9.5	—	144	1
7220 A DB DF DT			233 000	251 000	3 200	4 300	114.8	46.8	107	173	1
7220 B DB DF DT			212 000	229 000	2 200	3 000	151.5	83.5	107	173	1
7220 C DB DF DT			242 000	254 000	4 500	6 300	71.5	3.5	—	173	1
7320 A DB DF DT			335 000	385 000	2 200	3 000	137.9	43.9	107	208	1
7320 B DB DF DT			310 000	355 000	2 000	2 800	179.2	85.2	107	208	1
7921 A5 DB DF DT			78 500	108 000	4 300	6 000	78.3	38.3	—	140	0.6
7921 C DB DF DT			83 000	114 000	5 300	7 100	53.5	13.5	—	140	0.6
7021 A DB DF DT			130 000	163 000	3 400	4 500	102.5	50.5	—	154	1
7021 C DB DF DT			143 000	179 000	4 800	6 700	61.5	9.5	—	154	1
7221 A DB DF DT			254 000	283 000	3 000	4 000	121.2	49.2	112	183	1
7221 B DB DF DT			231 000	258 000	2 200	3 000	159.8	87.8	112	183	1
7221 C DB DF DT			264 000	286 000	4 300	6 000	75.5	3.5	—	183	1
7321 A DB DF DT			335 000	385 000	2 200	2 800	144.3	46.3	—	218	1
7321 B DB DF DT			310 000	355 000	1 900	2 600	187.4	89.4	—	218	1
7922 A5 DB DF DT			79 500	112 000	4 300	5 600	80.6	40.6	—	145	0.6
7922 C DB DF DT			84 500	119 000	5 000	6 700	54.8	14.8	—	145	0.6
7022 A DB DF DT			157 000	191 000	3 200	4 300	108.8	52.8	—	164	1
7022 C DB DF DT			172 000	208 000	4 500	6 300	65.5	9.5	—	164	1
7222 A DB DF DT			276 000	315 000	2 800	4 000	127.5	51.5	117	193	1
7222 B DB DF DT			250 000	289 000	2 000	2 800	168.1	92.1	117	193	1
7222 C DB DF DT			286 000	320 000	4 000	5 600	79.5	3.5	—	193	1
7322 A DB DF DT			360 000	430 000	2 000	2 600	151.0	51.0	—	233	1
7322 B DB DF DT			325 000	395 000	1 800	2 400	196.8	96.8	—	233	1
7924 A5 DB DF DT			110 000	154 000	3 800	5 300	88.5	44.5	—	160	0.6
7924 C DB DF DT			117 000	162 000	4 500	6 300	60.2	16.2	—	160	0.6
7024 A DB DF DT			166 000	213 000	3 000	4 000	114.6	58.6	—	174	1
7224 A DB DF DT			297 000	355 000	2 600						

SINGLE/MATCHED MOUNTINGS

Bore Diameter 130~170 mm

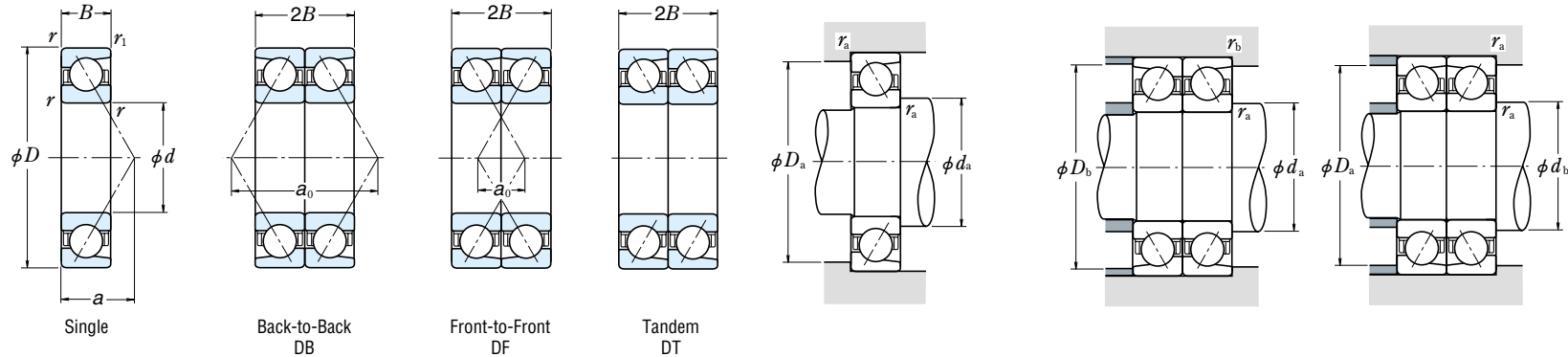

**Dynamic Equivalent Load**  $P = X F_r + Y F_a$

Contact Angle	$i f_0 F_a^* / C_{0r}$	$e$	Single, DT				DB or DF				
			$F_a/F_r \leq e$		$F_a/F_r > e$		$F_a/F_r \leq e$		$F_a/F_r > e$		
			X	Y	X	Y	X	Y	X	Y	
15°	0.178	0.38	1	0	0.44	1.47	1	1.65	0.72	2.39	
	0.357	0.40	1	0	0.44	1.40	1	1.57	0.72	2.28	
	0.714	0.43	1	0	0.44	1.30	1	1.46	0.72	2.11	
	1.07	0.46	1	0	0.44	1.23	1	1.38	0.72	2.00	
	1.43	0.47	1	0	0.44	1.19	1	1.34	0.72	1.93	
	2.14	0.50	1	0	0.44	1.12	1	1.26	0.72	1.82	
	3.57	0.55	1	0	0.44	1.02	1	1.14	0.72	1.66	
	5.35	0.56	1	0	0.44	1.00	1	1.12	0.72	1.63	
	25°	—	0.68	1	0	0.41	0.87	1	0.92	0.67	1.41
	30°	—	0.80	1	0	0.39	0.76	1	0.78	0.63	1.24
40°	—	1.14	1	0	0.35	0.57	1	0.55	0.57	0.93	

\*For  $i$ , use 2 for DB, DF and 1 for DT

**Static Equivalent Load**  $P_0 = X_0 F_r + Y_0 F_a$

Contact Angle	Single, DT		DB or DF		Single or DT mounting When $F_r > 0.5 F_r + Y_0 F_a$ use $P_0 = F_r$
	$X_0$	$Y_0$	$X_0$	$Y_0$	
15°	0.5	0.46	1	0.92	
25°	0.5	0.38	1	0.76	
30°	0.5	0.33	1	0.66	
40°	0.5	0.26	1	0.52	

	Boundary Dimensions (mm)				Basic Load Ratings (Single) (N)				Factor $f_0$	Limiting Speeds (1) (rpm)		Eff. Load Centers (mm) $a$	Abutment and Fillet Dimensions (mm)			Mass (kg) approx
	$d$	$D$	$B$	$r_{min}$ / $r_{1min}$	$C_r$	$C_{0r}$	$C_r$	$C_{0r}$		Grease	Oil		$d_{min}$	$D_{max}$	$r_{a,max}$	
130	180	24	1.5	1	74 000	86 000	7 550	8 750	—	4 300	6 000	48.1	139	171	1.5	1.54
	180	24	1.5	1	78 500	91 000	8 000	9 250	16.5	5 000	7 100	32.8	139	171	1.5	1.5
	200	33	2	1	117 000	125 000	12 000	12 800	—	3 400	4 500	64.1	140	190	2	3.68
	230	40	3	1.1	189 000	193 000	19 300	19 600	—	2 400	3 200	72.0	144	216	2.5	7.06
	230	40	3	1.1	171 000	175 000	17 400	17 800	—	2 200	3 000	95.5	144	216	2.5	7.1
	280	58	4	1.5	273 000	293 000	27 900	29 800	—	2 200	2 800	88.2	148	262	3	17.5
140	280	58	4	1.5	250 000	268 000	25 500	27 400	—	1 900	2 600	115.0	148	262	3	17.6
	190	24	1.5	1	75 000	90 000	7 650	9 200	—	4 000	5 600	50.5	149	181	1.5	1.63
	190	24	1.5	1	79 500	95 500	8 100	9 700	16.7	4 800	6 700	34.1	149	181	1.5	1.63
	210	33	2	1	120 000	133 000	12 200	13 500	—	3 200	4 300	67.0	150	200	2	3.9
	250	42	3	1.1	218 000	234 000	22 300	23 900	—	2 200	3 000	77.3	154	236	2.5	8.92
	250	42	3	1.1	197 000	213 000	20 100	21 700	—	2 000	2 800	102.8	154	236	2.5	8.94
150	300	62	4	1.5	300 000	335 000	30 500	34 500	—	2 000	2 600	94.5	158	282	3	21.4
	300	62	4	1.5	275 000	310 000	28 100	31 500	—	1 700	2 400	123.3	158	282	3	21.6
	210	28	2	1	96 500	115 000	9 850	11 800	—	3 800	5 000	56.0	160	200	2	2.97
	210	28	2	1	102 000	122 000	10 400	12 400	16.6	4 300	6 000	38.1	160	200	2	2.96
	225	35	2.1	1.1	137 000	154 000	14 000	15 700	—	2 400	3 000	71.6	162	213	2	4.75
	270	45	3	1.1	248 000	280 000	25 300	28 500	—	2 000	2 800	83.1	164	256	2.5	11.2
160	270	45	3	1.1	225 000	254 000	22 900	25 900	—	1 800	2 600	110.6	164	256	2.5	11.2
	320	65	4	1.5	315 000	370 000	32 500	38 000	—	1 800	2 400	100.3	168	302	3	26
	320	65	4	1.5	289 000	340 000	29 400	34 500	—	1 600	2 200	131.1	168	302	3	25.9
	220	28	2	1	106 000	133 000	10 800	13 500	16.7	3 800	5 000	39.4	170	210	2	3.1
	240	38	2.1	1.1	155 000	176 000	15 800	18 000	—	2 200	2 800	76.7	172	228	2	5.77
	290	48	3	1.1	263 000	305 000	26 800	31 500	—	1 900	2 600	89.0	174	276	2.5	14.1
170	290	48	3	1.1	238 000	279 000	24 200	28 400	—	1 700	2 400	118.4	174	276	2.5	14.2
	340	68	4	1.5	345 000	420 000	35 500	43 000	—	1 700	2 200	106.2	178	322	3	30.7
	340	68	4	1.5	315 000	385 000	32 000	39 500	—	1 500	2 000	138.9	178	322	3	30.8
	230	28	2	1	113 000	148 000	11 500	15 100	16.8	3 600	4 800	40.8	180	220	2	3.36
	260	42	2.1	1.1	186 000	214 000	19 000	21 900	—	2 000	2 600	83.1	182	248	2	7.9
	310	52	4	1.5	295 000	360 000	30 000	36 500	—	1 800	2 400	95.3	188	292	3	17.3
170	310	52	4	1.5	266 000	325 000	27 200	33 000	—	1 600	2 200	126.7	188	292	3	17.6
	360	72	4	1.5	390 000	485 000	39 500	49 500	—	1 600	2 200	112.5	188	342	3	35.8
	360	72	4	1.5	355 000	445 000	36 000	45 500	—	1 400	2 000	147.2	188	342	3	35.6

Notes (1) For applications operating near the limiting speed, refer to Page B49.  
 (2) The suffixes A, A5, B, and C represent contact angles of 30°, 25°, 40°, and 15° respectively.

Bearing Numbers (°)	Basic Load Ratings (Matched) (N)				Limiting Speeds (1) (Matched) (rpm)		Load Center Spacings (mm)		Abutment and Fillet Dimensions (mm)		
	Single	Duplex	$C_r$	$C_{0r}$	Grease	Oil	DB	DF	$d_b^{(3)}$ min	$D_b$ max	$r_b^{(3)}$ max
<b>7926 A5 DB DF DT</b>	120 000	172 000	12 300	17 500	3 400	4 800	96.3	48.3	—	174	1
<b>7926 C DB DF DT</b>	128 000	182 000	13 000	18 500	4 000	5 600	65.5	17.5	—	174	1
<b>7026 A DB DF DT</b>	191 000	251 000	19 400	25 600	2 600	3 600	128.3	62.3	—	194	1
<b>7226 A DB DF DT</b>	310 000	385 000	31 500	39 500	1 900	2 600	143.9	63.9	—	223	1
<b>7226 B DB DF DT</b>	278 000	350 000	28 300	35 500	1 700	2 400	191.0	111.0	—	223	1
<b>7326 A DB DF DT</b>	445 000	585 000	45 500	59 500	1 700	2 200	176.3	60.3	—	271	1.5
<b>7326 B DB DF DT</b>	405 000	535 000	41 500	54 500	1 500	2 000	230.0	114.0	—	271	1.5
<b>7928 A5 DB DF DT</b>	122 000	180 000	12 400	18 400	3 200	4 500	100.9	52.9	—	184	1
<b>7928 C DB DF DT</b>	129 000	191 000	13 200	19 400	3 800	5 300	68.2	20.2	—	184	1
<b>7028 A DB DF DT</b>	194 000	265 000	19 800	27 000	2 600	3 400	134.0	68.0	—	204	1
<b>7228 A DB DF DT</b>	355 000	470 000	36 000	48 000	1 800	2 400	154.6	70.6	—	243	1
<b>7228 B DB DF DT</b>	320 000	425 000	32 500	43 500	1 600	2 200	205.6	121.6	—	243	1
<b>7328 A DB DF DT</b>	490 000	670 000	50 000	68 500	1 600	2 000	189.0	65.0	—	291	1.5
<b>7328 B DB DF DT</b>	445 000	615 000	45 500	63 000	1 400	1 900	246.6	122.6	—	291	1.5
<b>7930 A5 DB DF DT</b>	157 000	231 000	16 000	23 500	3 000	4 000	112.0	56.0	—	204	1
<b>7930 C DB DF DT</b>	166 000	244 000	16 900	24 900	3 600	4 800	76.2	20.2	—	204	1
<b>7030 A DB DF DT</b>	222 000	305 000	22 700	31 500	1 900	2 400	143.3	73.3	—	218	1
<b>7230 A DB DF DT</b>	405 000	560 000	41 000	57 000	1 600	2 200	166.3	76.3	—	263	1
<b>7230 B DB DF DT</b>	365 000	510 000	37 000	52 000	1 500	2 000	221.2	131.2	—	263	1
<b>7330 A DB DF DT</b>	515 000	745 000	52 500	75 500	1 500	1 900	200.7	70.7	—	311	1.5
<b>7330 B DB DF DT</b>	470 000	680 000	48 000	69 500	1 300	1 800	262.2	132.2	—	311	1.5
<b>7932 A DB DF DT</b>	173 000	265 000	17 600	27 000	3 000	4 000	78.9	22.9	—	214	1
<b>7032 A DB DF DT</b>	252 000	355 000	25 700	36 000	1 700	2 400	153.5	77.5	—	233	1
<b>7232 A DB DF DT</b>	425 000	615 000	43 500	62 500	1 500	2 000	177.9	81.9	—	283	1
<b>7232 B DB DF DT</b>	385 000	555 000	39 500	57 000	1 400	1 900	236.8	140.8	—	283	1
<b>7332 A DB DF DT</b>	565 000	845 000	57 500	86 000	1 400	1 800	212.3	76.3	—	331	1.5
<b>7332 B DB DF DT</b>	515 000	770 000	52 500	78 500	1 200	1 700	277.8	141.8	—	331	

SINGLE/MATCHED MOUNTINGS

Bore Diameter 180~200 mm

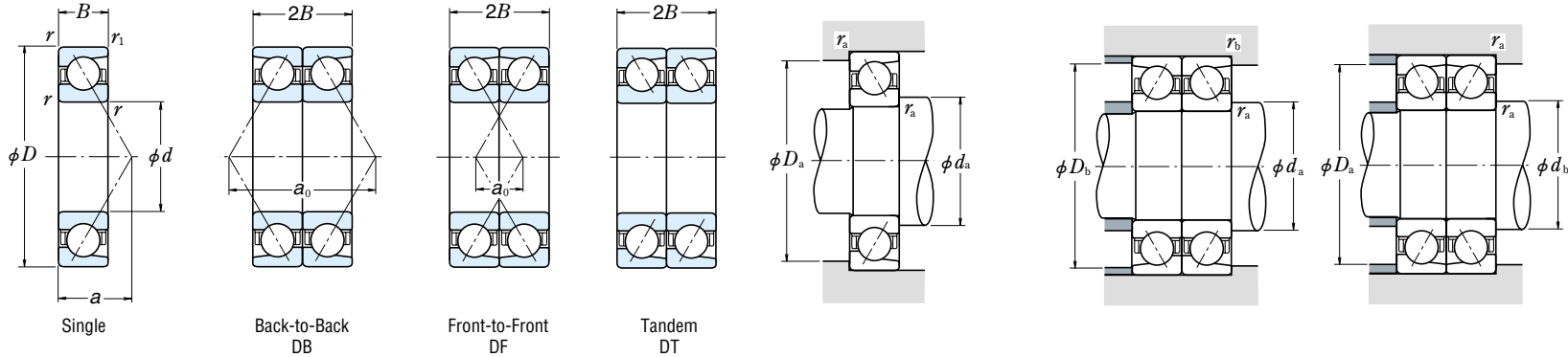

	Boundary Dimensions (mm)				Basic Load Ratings (Single) (N)				Factor $f_0$	Limiting Speeds <sup>(1)</sup> (rpm)		Eff. Load Centers (mm) $a$	Abutment and Fillet Dimensions (mm)			Mass (kg) approx
	$d$	$D$	$B$	$r_{min}$	$C_r$	$C_{0r}$	$C_r$	$C_{0r}$		Grease	Oil		$d_{min}$	$D_{a max}$	$r_{a max}$	
<b>180</b>	250	33	2	1	145 000	184 000	14 800	18 800	16.6	3 200	4 500	45.3	190	240	2	4.9
	280	46	2.1	1.1	207 000	252 000	21 100	25 700	—	1 900	2 400	89.4	192	268	2	10.5
	320	52	4	1.5	305 000	385 000	31 000	39 000	—	1 700	2 200	98.2	198	302	3	18.1
	320	52	4	1.5	276 000	350 000	28 100	35 500	—	1 500	2 000	130.9	198	302	3	18.4
	380	75	4	1.5	410 000	535 000	41 500	54 500	—	1 500	2 000	118.3	198	362	3	42.1
<b>190</b>	260	33	2	1	147 000	192 000	15 000	19 600	16.7	3 000	4 300	46.6	200	250	2	4.98
	290	46	2.1	1.1	224 000	280 000	22 800	28 600	—	1 800	2 400	92.3	202	278	2	11.3
	340	55	4	1.5	315 000	410 000	32 000	42 000	—	1 600	2 200	104.0	208	322	3	22.4
	340	55	4	1.5	284 000	375 000	28 900	38 000	—	1 400	2 000	138.7	208	322	3	22.5
	400	78	5	2	450 000	600 000	46 000	61 000	—	1 400	1 900	124.2	212	378	4	47.5
<b>200</b>	360	58	4	1.5	335 000	450 000	34 500	46 000	—	1 300	1 700	162.8	212	378	4	47.2
	280	38	2.1	1.1	189 000	244 000	19 300	24 900	16.5	2 800	4 000	51.2	212	268	2	6.85
	310	51	2.1	1.1	240 000	310 000	24 500	31 500	—	1 700	2 200	99.1	212	298	2	13.7
	360	58	4	1.5	335 000	450 000	34 500	46 000	—	1 500	2 000	109.8	218	342	3	26.5
	360	58	4	1.5	305 000	410 000	31 000	41 500	—	1 300	1 800	146.5	218	342	3	26.6

**Notes** <sup>(1)</sup> For applications operating near the limiting speed, refer to Page B49.  
<sup>(2)</sup> The suffixes A, A5, B, and C represent contact angles of 30°, 25°, 40°, and 15° respectively.

Dynamic Equivalent Load  $P = XF_r + YF_a$

Contact Angle	$i f_0 F_a^*$ $C_{0r}$	$e$	Single, DT				DB or DF			
			$F_a/F_r \leq e$		$F_a/F_r > e$		$F_a/F_r \leq e$		$F_a/F_r > e$	
			X	Y	X	Y	X	Y	X	Y
15°	0.178	0.38	1	0	0.44	1.47	1	1.65	0.72	2.39
	0.357	0.40	1	0	0.44	1.40	1	1.57	0.72	2.28
	0.714	0.43	1	0	0.44	1.30	1	1.46	0.72	2.11
	1.07	0.46	1	0	0.44	1.23	1	1.38	0.72	2.00
	1.43	0.47	1	0	0.44	1.19	1	1.34	0.72	1.93
	2.14	0.50	1	0	0.44	1.12	1	1.26	0.72	1.82
	3.57	0.55	1	0	0.44	1.02	1	1.14	0.72	1.66
	5.35	0.56	1	0	0.44	1.00	1	1.12	0.72	1.63
	25°	—	0.68	1	0	0.41	0.87	1	0.92	0.67
30°	—	0.80	1	0	0.39	0.76	1	0.78	0.63	1.24
40°	—	1.14	1	0	0.35	0.57	1	0.55	0.57	0.93

\*For  $i$ , use 2 for DB, DF and 1 for DT

Static Equivalent Load  $P_0 = X_0 F_r + Y_0 F_a$

Contact Angle	Single, DT		DB or DF		Single or DT mounting When $F_r > 0.5 F_r + Y_0 F_a$ use $P_0 = F_r$
	$X_0$	$Y_0$	$X_0$	$Y_0$	
15°	0.5	0.46	1	0.92	
25°	0.5	0.38	1	0.76	
30°	0.5	0.33	1	0.66	
40°	0.5	0.26	1	0.52	

Bearing Numbers <sup>(2)</sup>	Basic Load Ratings (Matched) (N)				Limiting Speeds <sup>(1)</sup> (Matched) (rpm)		Load Center Spacings (mm)		Abutment and Fillet Dimensions (mm)		
	Single	Duplex	$C_r$	$C_{0r}$	Grease	Oil	DB	DF	$d_{b min}^{(3)}$	$D_{b max}$	$r_{b max}^{(3)}$
<b>7936 C DB DF DT</b>			236 000	370 000	2 600	3 600	90.6	24.6	—	244	1
<b>7036 A DB DF DT</b>			335 000	505 000	1 500	2 000	178.8	86.8	—	273	1
<b>7236 A DB DF DT</b>			495 000	770 000	1 400	1 800	196.3	92.3	—	311	1.5
<b>7236 B DB DF DT</b>			450 000	700 000	1 200	1 700	261.8	157.8	—	311	1.5
<b>7336 A DB DF DT</b>			665 000	1 070 000	1 200	1 600	236.6	86.6	—	371	1.5
<b>7336 B DB DF DT</b>			605 000	975 000	1 100	1 500	309.9	159.9	—	371	1.5
<b>7938 C DB DF DT</b>			239 000	385 000	2 400	3 400	93.3	27.3	—	254	1
<b>7038 A DB DF DT</b>			365 000	560 000	1 400	1 900	184.6	92.6	—	283	1
<b>7238 A DB DF DT</b>			510 000	825 000	1 300	1 700	208.0	98.0	—	331	1.5
<b>7238 B DB DF DT</b>			460 000	750 000	1 100	1 600	277.3	167.3	—	331	1.5
<b>7338 A DB DF DT</b>			730 000	1 200 000	1 100	1 500	248.3	92.3	—	390	2
<b>7338 B DB DF DT</b>			670 000	1 100 000	1 000	1 400	325.5	169.5	—	390	2
<b>7940 C DB DF DT</b>			305 000	490 000	2 200	3 200	102.3	26.3	—	273	1
<b>7040 A DB DF DT</b>			390 000	620 000	1 300	1 800	198.2	96.2	—	303	1
<b>7240 A DB DF DT</b>			550 000	900 000	1 200	1 600	219.6	103.6	—	351	1.5
<b>7240 B DB DF DT</b>			495 000	815 000	1 100	1 500	292.9	176.9	—	351	1.5
<b>7340 A DB DF DT</b>			770 000	1 320 000	1 100	1 400	259.0	99.0	—	410	2
<b>7340 B DB DF DT</b>			700 000	1 200 000	950	1 300	340.1	180.1	—	410	2

**Note** <sup>(3)</sup> For bearings marked — in the column for  $d_b$ ,  $D_b$  and  $r_b$  for shafts are  $d_a$  (min) and  $r_a$  (max) respectively.

Bore Diameter 10~85 mm

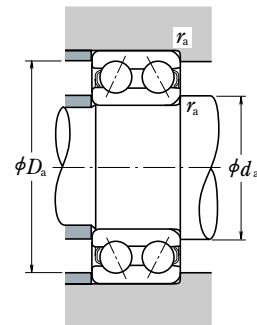
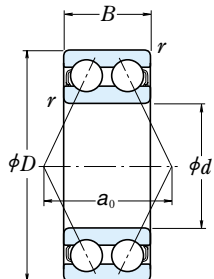

Dynamic Equivalent Load

$$P = XF_r + YF_a$$

$F_a/F_r \leq e$		$F_a/F_r > e$		$e$
X	Y	X	Y	
1	0.92	0.67	1.41	0.68

Static Equivalent Load

$$P_0 = F_r + 0.76 F_a$$

Boundary Dimensions (mm)				Basic Load Ratings				Limiting Speeds (rpm)		Bearing Numbers
$d$	$D$	$B$	$r_{min}$	$C_r$ (N)	$C_{0r}$ (kgf)	$C_r$ (kgf)	$C_{0r}$ (kgf)	Grease	Oil	
10	30	14.3	0.6	7 150	3 900	730	400	17 000	22 000	5200
12	32	15.9	0.6	10 500	5 800	1 070	590	15 000	20 000	5201
15	35	15.9	0.6	11 700	7 050	1 190	715	13 000	17 000	5202
	42	19	1	17 600	10 200	1 800	1 040	11 000	15 000	5302
17	40	17.5	0.6	14 600	9 050	1 490	920	11 000	15 000	5203
	47	22.2	1	21 000	12 600	2 140	1 280	10 000	13 000	5303
20	47	20.6	1	19 600	12 400	2 000	1 270	10 000	13 000	5204
	52	22.2	1.1	24 600	15 000	2 510	1 530	9 000	12 000	5304
25	52	20.6	1	21 300	14 700	2 170	1 500	8 500	11 000	5205
	62	25.4	1.1	32 500	20 700	3 350	2 110	7 500	10 000	5305
30	62	23.8	1	29 600	21 100	3 000	2 150	7 100	9 500	5206
	72	30.2	1.1	40 500	28 100	4 150	2 870	6 300	8 500	5306
35	72	27	1.1	39 000	28 700	4 000	2 920	6 300	8 000	5207
	80	34.9	1.5	51 000	36 000	5 200	3 700	5 600	7 500	5307
40	80	30.2	1.1	44 000	33 500	4 500	3 400	5 600	7 100	5208
	90	36.5	1.5	56 500	41 000	5 800	4 200	5 300	6 700	5308
45	85	30.2	1.1	49 500	38 000	5 050	3 900	5 000	6 700	5209
	100	39.7	1.5	68 500	51 000	7 000	5 200	4 500	6 000	5309
50	90	30.2	1.1	53 000	43 500	5 400	4 400	4 800	6 000	5210
	110	44.4	2	81 500	61 500	8 300	6 250	4 300	5 600	5310
55	100	33.3	1.5	56 000	49 000	5 700	5 000	4 300	5 600	5211
	120	49.2	2	95 000	73 000	9 700	7 450	3 800	5 000	5311
60	110	36.5	1.5	69 000	62 000	7 050	6 300	3 800	5 000	5212
	130	54	2.1	125 000	98 500	12 800	10 000	3 400	4 500	5312
65	120	38.1	1.5	76 500	69 000	7 800	7 050	3 600	4 500	5213
	140	58.7	2.1	142 000	113 000	14 500	11 500	3 200	4 300	5313
70	125	39.7	1.5	94 000	82 000	9 600	8 400	3 400	4 500	5214
	150	63.5	2.1	159 000	128 000	16 200	13 100	3 000	3 800	5314
75	130	41.3	1.5	93 500	83 000	9 550	8 500	3 200	4 300	5215
	80	44.4	2	99 000	93 000	10 100	9 500	3 000	3 800	5216
85	150	49.2	2	116 000	110 000	11 800	11 200	2 800	3 600	5217

Load Center Spacings (mm) $a_0$	Abutment and Fillet Dimensions (mm)			Mass (kg) approx
	$d_{a min}$	$D_{a max}$	$r_{a max}$	
14.5	15	25	0.6	0.050
16.7	17	27	0.6	0.060
18.3	20	30	0.6	0.070
	22.0	21	36	1
20.8	22	35	0.6	0.090
	25.0	23	41	1
24.3	26	41	1	0.12
	26.7	27	45	1
26.8	31	46	1	0.19
	31.8	32	55	1
31.6	36	56	1	0.29
	36.5	37	65	1
36.6	42	65	1	0.43
	41.6	44	71	1.5
41.5	47	73	1	0.57
	45.5	49	81	1.5
43.4	52	78	1	0.62
	50.6	54	91	1.5
45.9	57	83	1	0.67
	55.6	60	100	2
50.1	64	91	1.5	0.96
	60.6	65	110	2
56.5	69	101	1.5	1.35
	69.2	72	118	2
59.7	74	111	1.5	1.65
	72.8	77	128	2
63.8	79	116	1.5	1.8
	78.3	82	138	2
66.1	84	121	1.5	1.9
	69.6	90	130	2
75.3	95	140	2	3.4

Bore Diameter 30~95 mm

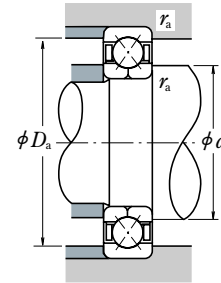
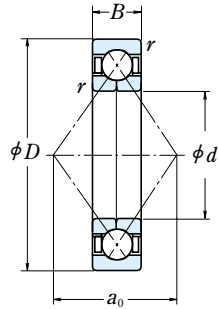

Dynamic Equivalent Load  
 $P_a = F_a$

Static Equivalent Load  
 $P_{0a} = F_a$

Boundary Dimensions (mm)				Basic Load Ratings				Limiting Speeds (rpm)	
d	D	B	r min	(N)		{kgf}		Grease	Oil
				$C_a$	$C_{0a}$	$C_a$	$C_{0a}$		
30	62	16	1	31 000	45 000	3 150	4 600	8 500	12 000
	72	19	1.1	46 000	63 000	4 700	6 450	8 000	11 000
35	72	17	1.1	41 000	61 500	4 200	6 250	7 500	10 000
	80	21	1.5	55 000	80 000	5 600	8 150	7 100	9 500
40	80	18	1.1	49 000	77 500	5 000	7 900	6 700	9 000
	90	23	1.5	67 000	100 000	6 850	10 200	6 300	8 500
45	85	19	1.1	55 000	88 500	5 600	9 000	6 300	8 500
	100	25	1.5	87 500	133 000	8 900	13 500	5 600	7 500
50	90	20	1.1	57 000	97 000	5 850	9 900	5 600	8 000
	110	27	2	102 000	159 000	10 400	16 200	5 000	6 700
55	100	21	1.5	71 000	122 000	7 200	12 500	5 300	7 100
	120	29	2	118 000	187 000	12 000	19 100	4 500	6 300
60	110	22	1.5	85 500	150 000	8 750	15 300	4 800	6 300
	130	31	2.1	135 000	217 000	13 800	22 200	4 300	5 600
65	120	23	1.5	97 500	179 000	9 950	18 300	4 300	6 000
	140	33	2.1	153 000	250 000	15 600	25 500	3 800	5 300
70	125	24	1.5	106 000	197 000	10 800	20 100	4 000	5 600
	150	35	2.1	172 000	285 000	17 500	29 100	3 600	5 000
75	130	25	1.5	110 000	212 000	11 200	21 700	3 800	5 300
	160	37	2.1	187 000	320 000	19 100	33 000	3 400	4 800
80	125	22	1.1	77 000	167 000	7 850	17 000	3 800	5 300
	140	26	2	124 000	236 000	12 600	24 100	3 600	5 000
	170	39	2.1	202 000	360 000	20 600	37 000	3 200	4 300
85	130	22	1.1	79 000	176 000	8 050	18 000	3 800	5 000
	150	28	2	143 000	276 000	14 600	28 200	3 400	4 800
	180	41	3	218 000	405 000	22 300	41 000	3 000	4 000
90	140	24	1.5	94 000	208 000	9 600	21 200	3 400	4 800
	160	30	2	164 000	320 000	16 700	32 500	3 200	4 300
	190	43	3	235 000	450 000	23 900	45 500	2 800	3 800
95	145	24	1.5	96 500	220 000	9 800	22 500	3 400	4 500
	170	32	2.1	177 000	340 000	18 000	35 000	3 000	4 000
	200	45	3	251 000	495 000	25 600	50 500	2 600	3 600

Bearing Numbers	Load Center Spacings (mm) $a_0$	Abutment and Fillet Dimensions (mm)			Mass (kg) approx
		$d_a$ min	$D_a$ max	$r_a$ max	
<b>QJ 206</b>	32.2	36	56	1	0.24
<b>QJ 306</b>	35.7	37	65	1	0.42
<b>QJ 207</b>	37.5	42	65	1	0.35
<b>QJ 307</b>	40.3	44	71	1.5	0.57
<b>QJ 208</b>	42.0	47	73	1	0.45
<b>QJ 308</b>	45.5	49	81	1.5	0.78
<b>QJ 209</b>	45.5	52	78	1	0.52
<b>QJ 309</b>	50.8	54	91	1.5	1.05
<b>QJ 210</b>	49.0	57	83	1	0.59
<b>QJ 310</b>	56.0	60	100	2	1.35
<b>QJ 211</b>	54.3	64	91	1.5	0.77
<b>QJ 311</b>	61.3	65	110	2	1.75
<b>QJ 212</b>	59.5	69	101	1.5	0.98
<b>QJ 312</b>	66.5	72	118	2	2.15
<b>QJ 213</b>	64.8	74	111	1.5	1.2
<b>QJ 313</b>	71.8	77	128	2	2.7
<b>QJ 214</b>	68.3	79	116	1.5	1.3
<b>QJ 314</b>	77.0	82	138	2	3.18
<b>QJ 215</b>	71.8	84	121	1.5	1.5
<b>QJ 315</b>	82.3	87	148	2	3.9
<b>QJ 1016</b>	71.8	87	118	1	1.05
<b>QJ 216</b>	77.0	90	130	2	1.85
<b>QJ 316</b>	87.5	92	158	2	4.6
<b>QJ 1017</b>	75.3	92	123	1	1.1
<b>QJ 217</b>	82.3	95	140	2	2.2
<b>QJ 317</b>	92.8	99	166	2.5	5.34
<b>QJ 1018</b>	80.5	99	131	1.5	1.45
<b>QJ 218</b>	87.5	100	150	2	2.75
<b>QJ 318</b>	98.0	104	176	2.5	6.4
<b>QJ 1019</b>	84.0	104	136	1.5	1.5
<b>QJ 219</b>	92.8	107	158	2	3.35
<b>QJ 319</b>	103.3	109	186	2.5	7.4

Remarks When using four-point contact ball bearings, please contact NSK.



Bore Diameter 100~200 mm

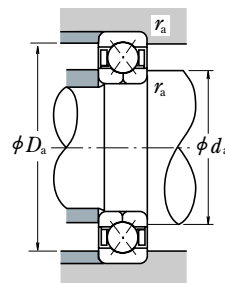
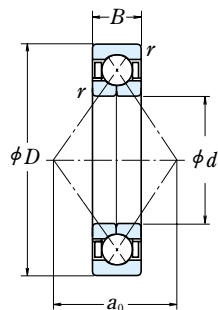

Dynamic Equivalent Load

$$P_a = F_a$$

Static Equivalent Load

$$P_{0a} = F_a$$

Boundary Dimensions (mm)				Basic Load Ratings				Limiting Speeds (rpm)	
d	D	B	r min	(N)		(kgf)		Grease	Oil
				C <sub>a</sub>	C <sub>0a</sub>	C <sub>a</sub>	C <sub>0a</sub>		
100	150	24	1.5	98 000	232 000	10 000	23 700	3 200	4 300
	180	34	2.1	199 000	390 000	20 300	39 500	2 800	3 800
	215	47	3	300 000	640 000	31 000	65 500	2 400	3 400
105	160	26	2	115 000	269 000	11 800	27 400	3 000	4 000
	190	36	2.1	217 000	435 000	22 100	44 500	2 600	3 600
	225	49	3	305 000	640 000	31 000	65 500	2 400	3 200
110	170	28	2	139 000	315 000	14 200	32 000	2 800	3 800
	200	38	2.1	235 000	490 000	24 000	50 000	2 600	3 400
	240	50	3	320 000	710 000	32 500	72 500	2 200	3 000
120	180	28	2	147 000	350 000	15 000	36 000	2 600	3 600
	215	40	2.1	265 000	585 000	27 000	60 000	2 400	3 200
	260	55	3	360 000	835 000	36 500	85 500	2 000	2 800
130	200	33	2	169 000	415 000	17 300	42 000	2 400	3 200
	230	40	3	274 000	635 000	28 000	65 000	2 200	3 000
	280	58	4	400 000	970 000	40 500	99 000	1 900	2 600
140	210	33	2	172 000	435 000	17 600	44 500	2 200	3 000
	250	42	3	315 000	775 000	32 000	79 000	2 000	2 800
	300	62	4	440 000	1 110 000	44 500	114 000	1 700	2 400
150	225	35	2.1	197 000	505 000	20 100	51 500	2 000	2 800
	270	45	3	360 000	925 000	36 500	94 500	1 800	2 600
	320	65	4	460 000	1 230 000	47 000	125 000	1 600	2 200
160	240	38	2.1	224 000	580 000	22 800	59 000	1 900	2 600
	290	48	3	380 000	1 010 000	39 000	103 000	1 700	2 400
	340	68	4	505 000	1 400 000	51 500	143 000	1 500	2 000
170	260	42	2.1	268 000	705 000	27 300	72 000	1 800	2 400
	310	52	4	425 000	1 180 000	43 500	121 000	1 600	2 200
	360	72	4	565 000	1 610 000	57 500	164 000	1 400	2 000
180	280	46	2.1	299 000	830 000	30 500	84 500	1 700	2 200
	320	52	4	440 000	1 270 000	45 000	130 000	1 500	2 000
	380	75	4	595 000	1 770 000	60 500	180 000	1 300	1 800
190	290	46	2.1	325 000	925 000	33 000	94 000	1 600	2 200
	340	55	4	455 000	1 360 000	46 500	139 000	1 400	2 000
	400	78	5	655 000	1 980 000	67 000	202 000	1 300	1 700
200	310	51	2.1	345 000	1 020 000	35 500	104 000	1 500	2 000
	360	58	4	490 000	1 480 000	49 500	151 000	1 300	1 800
	420	80	5	690 000	2 180 000	70 500	222 000	1 200	1 600

Bearing Numbers	Load Center Spacings (mm) a <sub>0</sub>	Abutment and Fillet Dimensions (mm)			Mass (kg) approx
		d <sub>a</sub> min	D <sub>a</sub> max	r <sub>a</sub> max	
<b>QJ 1020</b>	87.5	109	141	1.5	1.6
<b>QJ 220</b>	98.0	112	168	2	4.0
<b>QJ 320</b>	110.3	114	201	2.5	9.3
<b>QJ 1021</b>	92.8	115	150	2	2.0
<b>QJ 221</b>	103.3	117	178	2	4.7
<b>QJ 321</b>	115.5	119	211	2.5	10.5
<b>QJ 1022</b>	98.0	120	160	2	2.5
<b>QJ 222</b>	108.5	122	188	2	5.6
<b>QJ 322</b>	122.5	124	226	2.5	12.5
<b>QJ 1024</b>	105.0	130	170	2	2.65
<b>QJ 224</b>	117.3	132	203	2	6.9
<b>QJ 324</b>	133.0	134	246	2.5	15.4
<b>QJ 1026</b>	115.5	140	190	2	4.0
<b>QJ 226</b>	126.0	144	216	2.5	7.7
<b>QJ 326</b>	143.5	148	262	3	19
<b>QJ 1028</b>	122.5	150	200	2	4.3
<b>QJ 228</b>	136.5	154	236	2.5	9.8
<b>QJ 328</b>	154.0	158	282	3	24
<b>QJ 1030</b>	131.3	162	213	2	5.2
<b>QJ 230</b>	147.0	164	256	2.5	12
<b>QJ 330</b>	164.5	168	302	3	29
<b>QJ 1032</b>	140.0	172	228	2	6.4
<b>QJ 232</b>	157.5	174	276	2.5	15
<b>QJ 332</b>	175.1	178	322	3	31
<b>QJ 1034</b>	150.5	182	248	2	8.6
<b>QJ 234</b>	168.0	188	292	3	19.5
<b>QJ 334</b>	185.6	188	342	3	41
<b>QJ 1036</b>	161.0	192	268	2	11
<b>QJ 236</b>	175.1	198	302	3	20.5
<b>QJ 336</b>	196.1	198	362	3	48
<b>QJ 1038</b>	168.0	202	278	2	11.5
<b>QJ 238</b>	185.6	208	322	3	23
<b>QJ 338</b>	206.6	212	378	4	54.5
<b>QJ 1040</b>	178.6	212	298	2	15
<b>QJ 240</b>	196.1	218	342	3	27
<b>QJ 340</b>	217.1	222	398	4	61.5

Remarks When using four-point contact ball bearings, please contact NSK.

# SELF-ALIGNING BALL BEARINGS

## SELF-ALIGNING BALL BEARINGS

Bore Diameter 5-110mm.....Pages B74-B79

### DESIGN, TYPES, AND FEATURES

The outer ring has a spherical raceway and its center of curvature coincides with that of the bearing; therefore, the axis of the inner ring, balls and cage can deflect to some extent around the bearing center. This type is recommended when the alignment of the shaft and housing is difficult and when the shaft may bend. Since the contact angle is small, the axial load capacity is low.

Pressed steel cages are usually used.

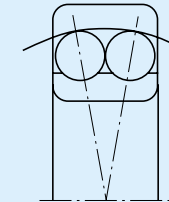

### PROTRUSION AMOUNT OF BALLS

Among self-aligning ball bearings, there are some in which the balls protrude from the side face as shown below. This protrusion amount  $b_1$  is listed in the following table.

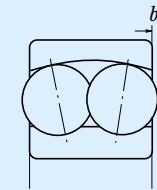

Bearing No.	$b_1$ (mm)
2222(K), 2316(K)	0.5
2319(K), 2320(K) 2321, 2322(K)	0.5
1318(K)	1.5
1319(K)	2
1320(K), 1321 1322(K)	3

### TOLERANCES AND RUNNING ACCURACY

Table 8.2 (Pages A60-A63)

### RECOMMENDED FITS

Table 9.2 (Page A84)  
Table 9.4 (Page A85)

### INTERNAL CLEARANCE

Table 9.12 (Page A90)

### PERMISSIBLE MISALIGNMENT

The permissible misalignment of self-aligning ball bearings is approximately 0.07 to 0.12 radian (4° to 7°) under normal loads. However, depending on the surrounding structure, such an angle may not be possible. Use care in the structural design.



Bore Diameter 5~30 mm

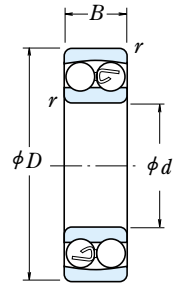

Cylindrical Bore

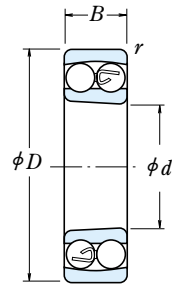

Tapered Bore

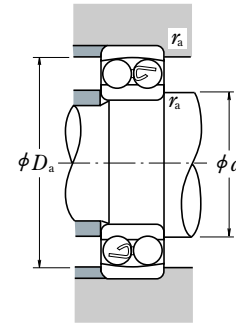

Dynamic Equivalent Load

$$P = XF_r + YF_a$$

$F_a/F_r \leq e$		$F_a/F_r > e$	
X	Y	X	Y
1	$Y_3$	0.65	$Y_2$

Static Equivalent Load

$$P_0 = F_r + Y_0 F_a$$

The values of  $e$ ,  $Y_2$ ,  $Y_3$ , and  $Y_0$  are listed in the table below.

Boundary Dimensions (mm)				Basic Load Ratings (N)				Limiting Speeds (rpm)		Bearing
$d$	$D$	$B$	$r_{min}$	$C_r$	$C_{0r}$	{kgf}		Grease	Oil	
5	19	6	0.3	2 530	475	258	49	30 000	36 000	135
6	19	6	0.3	2 530	475	258	49	30 000	36 000	126
7	22	7	0.3	2 750	600	280	61	26 000	32 000	127
8	22	7	0.3	2 750	600	280	61	26 000	32 000	108
9	26	8	0.6	4 150	895	425	91	26 000	30 000	129
10	30	9	0.6	5 550	1 190	570	121	22 000	28 000	1200
	30	14	0.6	7 450	1 590	760	162	24 000	28 000	2200
	35	11	0.6	7 350	1 620	750	165	20 000	24 000	1300
	35	17	0.6	9 200	2 010	935	205	18 000	22 000	2300
12	32	10	0.6	5 700	1 270	580	130	22 000	26 000	1201
	32	14	0.6	7 750	1 730	790	177	22 000	26 000	2201
	37	12	1	9 650	2 160	985	221	18 000	22 000	1301
	37	17	1	12 100	2 730	1 240	278	17 000	22 000	2301
15	35	11	0.6	7 600	1 750	775	179	18 000	22 000	1202
	35	14	0.6	7 800	1 850	795	188	18 000	22 000	2202
	42	13	1	9 700	2 290	990	234	16 000	20 000	1302
	42	17	1	12 300	2 910	1 250	296	14 000	18 000	2302
17	40	12	0.6	8 000	2 010	815	205	16 000	20 000	1203
	40	16	0.6	9 950	2 420	1 010	247	16 000	20 000	2203
	47	14	1	12 700	3 200	1 300	325	14 000	17 000	1303
	47	19	1	14 700	3 550	1 500	365	13 000	16 000	2303
20	47	14	1	10 000	2 610	1 020	266	14 000	17 000	1204
	47	18	1	12 800	3 300	1 310	340	14 000	17 000	2204
	52	15	1.1	12 600	3 350	1 280	340	12 000	15 000	1304
	52	21	1.1	18 500	4 700	1 880	480	11 000	14 000	2304
25	52	15	1	12 200	3 300	1 250	335	12 000	14 000	1205
	52	18	1	12 400	3 450	1 270	350	12 000	14 000	2205
	62	17	1.1	18 200	5 000	1 850	510	10 000	13 000	1305
	62	24	1.1	24 900	6 600	2 530	675	9 500	12 000	2305
30	62	16	1	15 800	4 650	1 610	475	10 000	12 000	1206
	62	20	1	15 300	4 550	1 560	460	10 000	12 000	2206
	72	19	1.1	21 400	6 300	2 190	645	8 500	11 000	1306
	72	27	1.1	32 000	8 750	3 250	895	8 000	10 000	2306

Numbers	Abutment and Fillet Dimensions (mm)			Constant	Axial Load Factors			Mass (kg)
	Tapered Bore <sup>(1)</sup>	$d_{a min}$	$D_{a max}$		$r_{a max}$	$e$	$Y_2$	
—	7	17	0.3	0.34	2.9	1.9	1.9	0.009
—	8	17	0.3	0.34	2.9	1.9	1.9	0.008
—	9	20	0.3	0.31	3.1	2.0	2.1	0.013
—	10	20	0.3	0.31	3.1	2.0	2.1	0.016
—	13	22	0.6	0.32	3.1	2.0	2.1	0.021
—	14	26	0.6	0.32	3.1	2.0	2.1	0.033
—	14	26	0.6	0.64	1.5	0.98	1.0	0.042
—	14	31	0.6	0.35	2.8	1.8	1.9	0.057
—	14	31	0.6	0.71	1.4	0.89	0.93	0.077
—	16	28	0.6	0.36	2.7	1.8	1.8	0.039
—	16	28	0.6	0.58	1.7	1.1	1.1	0.048
—	17	32	1	0.33	2.9	1.9	2.0	0.066
—	17	32	1	0.60	1.6	1.1	1.1	0.082
—	19	31	0.6	0.32	3.1	2.0	2.1	0.051
—	19	31	0.6	0.50	1.9	1.3	1.3	0.055
—	20	37	1	0.33	2.9	1.9	2.0	0.093
—	20	37	1	0.51	1.9	1.2	1.3	0.108
—	21	36	0.6	0.31	3.1	2.0	2.1	0.072
—	21	36	0.6	0.50	1.9	1.3	1.3	0.085
—	22	42	1	0.32	3.1	2.0	2.1	0.13
—	22	42	1	0.51	1.9	1.2	1.3	0.15
1204 K	25	42	1	0.29	3.4	2.2	2.3	0.12
2204 K	25	42	1	0.47	2.1	1.3	1.4	0.133
1304 K	26.5	45.5	1	0.29	3.4	2.2	2.3	0.165
2304 K	26.5	45.5	1	0.50	1.9	1.2	1.3	0.193
1205 K	30	47	1	0.28	3.5	2.3	2.4	0.14
2205 K	30	47	1	0.41	2.4	1.5	1.6	0.15
1305 K	31.5	55.5	1	0.28	3.5	2.3	2.4	0.255
2305 K	31.5	55.5	1	0.47	2.1	1.4	1.4	0.319
1206 K	35	57	1	0.25	3.9	2.5	2.6	0.22
2206 K	35	57	1	0.38	2.5	1.6	1.7	0.249
1306 K	36.5	65.5	1	0.26	3.7	2.4	2.5	0.385
2306 K	36.5	65.5	1	0.44	2.2	1.4	1.5	0.48

Note <sup>(1)</sup> The suffix K represents bearings with tapered bores (1 : 12)

Remarks For the dimensions related to adapters, refer to Page B354.

Bore Diameter 35~70 mm

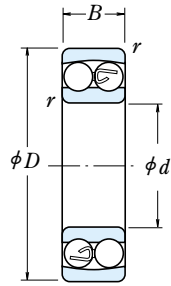

Cylindrical Bore

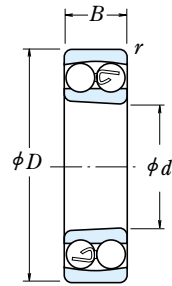

Tapered Bore

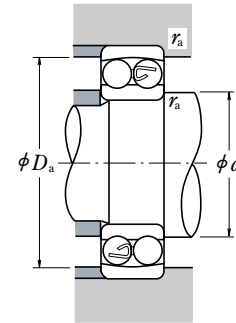

Dynamic Equivalent Load

$$P = XF_r + YF_a$$

$F_a/F_r \leq e$		$F_a/F_r > e$	
X	Y	X	Y
1	$Y_3$	0.65	$Y_2$

Static Equivalent Load

$$P_0 = F_r + Y_0 F_a$$

The values of  $e$ ,  $Y_2$ ,  $Y_3$ , and  $Y_0$  are listed in the table below.

Boundary Dimensions (mm)				Basic Load Ratings (N)				Limiting Speeds (rpm)		Bearing
$d$	$D$	$B$	$r_{min}$	$C_r$	$C_{0r}$	(kgf)		Grease	Oil	
						$C_r$	$C_{0r}$			Cylindrical Bore
35	72	17	1.1	15 900	5 100	1 620	520	8 500	10 000	1207
	72	23	1.1	21 700	6 600	2 210	675	8 500	10 000	2207
	80	21	1.5	25 300	7 850	2 580	800	7 500	9 500	1307
	80	31	1.5	40 000	11 300	4 100	1 150	7 100	9 000	2307
40	80	18	1.1	19 300	6 500	1 970	665	7 500	9 000	1208
	80	23	1.1	22 400	7 350	2 290	750	7 500	9 000	2208
	90	23	1.5	29 800	9 700	3 050	990	6 700	8 500	1308
	90	33	1.5	45 500	13 500	4 650	1 380	6 300	8 000	2308
45	85	19	1.1	22 000	7 350	2 240	750	7 100	8 500	1209
	85	23	1.1	23 300	8 150	2 380	830	7 100	8 500	2209
	100	25	1.5	38 500	12 700	3 900	1 300	6 000	7 500	1309
	100	36	1.5	55 000	16 700	5 600	1 700	5 600	7 100	2309
50	90	20	1.1	22 800	8 100	2 330	830	6 300	8 000	1210
	90	23	1.1	23 300	8 450	2 380	865	6 300	8 000	2210
	110	27	2	43 500	14 100	4 450	1 440	5 600	6 700	1310
	110	40	2	65 000	20 200	6 650	2 060	5 000	6 300	2310
55	100	21	1.5	26 900	10 000	2 750	1 020	6 000	7 100	1211
	100	25	1.5	26 700	9 900	2 720	1 010	6 000	7 100	2211
	120	29	2	51 500	17 900	5 250	1 820	5 000	6 300	1311
	120	43	2	76 500	24 000	7 800	2 450	4 800	6 000	2311
60	110	22	1.5	30 500	11 500	3 100	1 180	5 300	6 300	1212
	110	28	1.5	34 000	12 600	3 500	1 290	5 300	6 300	2212
	130	31	2.1	57 500	20 800	5 900	2 130	4 500	5 600	1312
	130	46	2.1	88 500	28 300	9 000	2 880	4 300	5 300	2312
65	120	23	1.5	31 000	12 500	3 150	1 280	4 800	6 000	1213
	120	31	1.5	43 500	16 400	4 450	1 670	4 800	6 000	2213
	140	33	2.1	62 500	22 900	6 350	2 330	4 300	5 300	1313
	140	48	2.1	97 000	32 500	9 900	3 300	3 800	4 800	2313
70	125	24	1.5	35 000	13 800	3 550	1 410	4 800	5 600	1214
	125	31	1.5	44 000	17 100	4 500	1 740	4 500	5 600	2214
	150	35	2.1	75 000	27 700	7 650	2 830	4 000	5 000	1314
	150	51	2.1	111 000	37 500	11 300	3 850	3 600	4 500	2314

Numbers	Abutment and Fillet Dimensions (mm)			Constant	Axial Load Factors			Mass (kg)	
	Tapered Bore <sup>(1)</sup>	$d_{a min}$	$D_{a max}$		$r_{a max}$	$e$	$Y_2$		$Y_3$
1207 K	—	41.5	65.5	1	0.23	4.2	2.7	2.8	0.32
	—	41.5	65.5	1	0.37	2.6	1.7	1.8	0.378
	—	43	72	1.5	0.26	3.8	2.5	2.6	0.51
	—	43	72	1.5	0.46	2.1	1.4	1.4	0.642
1208 K	—	46.5	73.5	1	0.22	4.3	2.8	2.9	0.415
	—	46.5	73.5	1	0.33	3.0	1.9	2.0	0.477
	—	48	82	1.5	0.24	4.0	2.6	2.7	0.715
	—	48	82	1.5	0.43	2.3	1.5	1.5	0.889
1209 K	—	51.5	78.5	1	0.21	4.7	3.0	3.1	0.465
	—	51.5	78.5	1	0.30	3.2	2.1	2.2	0.522
	—	53	92	1.5	0.25	4.0	2.6	2.7	0.955
	—	53	92	1.5	0.41	2.4	1.5	1.6	1.2
1210 K	—	56.5	83.5	1	0.21	4.7	3.1	3.2	0.525
	—	56.5	83.5	1	0.28	3.4	2.2	2.3	0.564
	—	59	101	2	0.23	4.2	2.7	2.8	1.25
	—	59	101	2	0.42	2.3	1.5	1.6	1.58
1211 K	—	63	92	1.5	0.20	4.9	3.2	3.3	0.705
	—	63	92	1.5	0.28	3.5	2.3	2.4	0.746
	—	64	111	2	0.23	4.2	2.7	2.8	1.6
	—	64	111	2	0.41	2.4	1.5	1.6	2.03
1212 K	—	68	102	1.5	0.18	5.3	3.4	3.6	0.90
	—	68	102	1.5	0.28	3.5	2.3	2.4	1.03
	—	71	119	2	0.23	4.3	2.8	2.9	2.03
	—	71	119	2	0.40	2.4	1.6	1.6	2.57
1213 K	—	73	112	1.5	0.17	5.7	3.7	3.8	1.15
	—	73	112	1.5	0.28	3.5	2.3	2.4	1.4
	—	76	129	2	0.23	4.2	2.7	2.9	2.54
	—	76	129	2	0.39	2.5	1.6	1.7	3.2
—	—	78	117	1.5	0.18	5.3	3.4	3.6	1.3
	—	78	117	1.5	0.26	3.7	2.4	2.5	1.52
	—	81	139	2	0.22	4.4	2.8	3.0	3.19
	—	81	139	2	0.38	2.6	1.7	1.8	3.9

Note <sup>(1)</sup> The suffix K represents bearings with tapered bores (1 : 12)

Remarks For the dimensions related to adapters, refer to Page B354 and B355.

Bore Diameter 75~110 mm

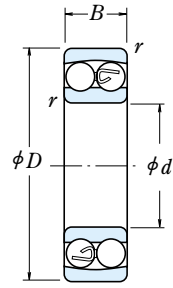

Cylindrical Bore

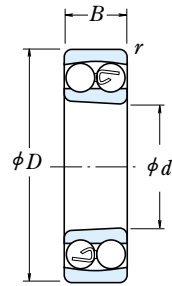

Tapered Bore

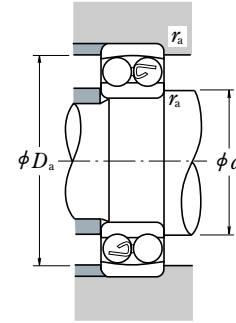

Dynamic Equivalent Load

$$P = XF_r + YF_a$$

$F_a/F_r \leq e$		$F_a/F_r > e$	
X	Y	X	Y
1	$Y_3$	0.65	$Y_2$

Static Equivalent Load

$$P_0 = F_r + Y_0 F_a$$

The values of  $e$ ,  $Y_2$ ,  $Y_3$ , and  $Y_0$  are listed in the table below.

Boundary Dimensions (mm)				Basic Load Ratings (N)				Limiting Speeds (rpm)		Bearing
$d$	$D$	$B$	$r_{min}$	$C_r$	$C_{0r}$	(kgf)		Grease	Oil	
75	130	25	1.5	39 000	15 700	4 000	1 600	4 300	5 300	1215
	130	31	1.5	44 500	17 800	4 550	1 820	4 300	5 300	2215
	160	37	2.1	80 000	30 000	8 150	3 050	3 800	4 500	1315
	160	55	2.1	125 000	43 000	12 700	4 400	3 400	4 300	2315
80	140	26	2	40 000	17 000	4 100	1 730	4 000	5 000	1216
	140	33	2	49 000	19 900	5 000	2 030	4 000	5 000	2216
	170	39	2.1	89 000	33 000	9 100	3 400	3 600	4 300	1316
	170	58	2.1	130 000	45 000	13 200	4 600	3 200	4 000	* 2316
85	150	28	2	49 500	20 800	5 050	2 120	3 800	4 500	1217
	150	36	2	58 500	23 600	5 950	2 400	3 800	4 800	2217
	180	41	3	98 500	38 000	10 000	3 850	3 400	4 000	1317
	180	60	3	142 000	51 500	14 500	5 250	3 000	3 800	2317
90	160	30	2	57 500	23 500	5 850	2 400	3 600	4 300	1218
	160	40	2	70 500	28 700	7 200	2 930	3 600	4 300	2218
	190	43	3	117 000	44 500	12 000	4 550	3 200	3 800	* 1318
	190	64	3	154 000	57 500	15 700	5 850	2 800	3 600	2318
95	170	32	2.1	64 000	27 100	6 550	2 770	3 400	4 000	1219
	170	43	2.1	84 000	34 500	8 550	3 500	3 400	4 000	2219
	200	45	3	129 000	51 000	13 200	5 200	3 000	3 600	* 1319
	200	67	3	161 000	64 500	16 400	6 550	2 800	3 400	* 2319
100	180	34	2.1	69 500	29 700	7 100	3 050	3 200	3 800	1220
	180	46	2.1	94 500	38 500	9 650	3 900	3 200	3 800	2220
	215	47	3	140 000	57 500	14 300	5 850	2 800	3 400	* 1320
	215	73	3	187 000	79 000	19 100	8 050	2 400	3 200	* 2320
105	190	36	2.1	75 000	32 500	7 650	3 300	3 000	3 600	1221
	190	50	2.1	109 000	45 000	11 100	4 550	3 000	3 600	2221
	225	49	3	154 000	64 500	15 700	6 600	2 600	3 200	* 1321
	225	77	3	200 000	87 000	20 400	8 850	2 400	3 000	* 2321
110	200	38	2.1	87 000	38 500	8 900	3 950	2 800	3 400	1222
	200	53	2.1	122 000	51 500	12 500	5 250	2 800	3 400	* 2222
	240	50	3	161 000	72 000	16 400	7 300	2 400	3 000	* 1322
	240	80	3	211 000	94 500	21 600	9 650	2 200	2 800	* 2322

Numbers	Abutment and Fillet Dimensions (mm)			Constant	Axial Load Factors			Mass (kg)	
	Tapered Bore <sup>(1)</sup>	$d_{a min}$	$D_{a max}$		$r_{a max}$	$e$	$Y_2$		$Y_3$
1215 K 2215 K 1315 K 2315 K		83	122	1.5	0.17	5.6	3.6	3.8	1.41
		83	122	1.5	0.25	3.9	2.5	2.6	1.6
		86	149	2	0.22	4.4	2.8	2.9	3.65
		86	149	2	0.38	2.5	1.6	1.7	4.77
1216 K 2216 K 1316 K * 2316 K		89	131	2	0.16	6.0	3.9	4.1	1.73
		89	131	2	0.25	3.9	2.5	2.7	1.97
		91	159	2	0.22	4.5	2.9	3.1	4.31
		91	159	2	0.39	2.5	1.6	1.7	5.54
1217 K 2217 K 1317 K 2317 K		94	141	2	0.17	5.7	3.7	3.8	2.09
		94	141	2	0.25	3.9	2.5	2.6	2.48
		98	167	2.5	0.21	4.6	2.9	3.1	5.13
		98	167	2.5	0.37	2.6	1.7	1.8	6.56
1218 K 2218 K * 1318 K 2318 K		99	151	2	0.17	5.8	3.8	3.9	2.55
		99	151	2	0.27	3.7	2.4	2.5	3.13
		103	177	2.5	0.22	4.3	2.8	2.9	5.94
		103	177	2.5	0.38	2.6	1.7	1.7	7.76
1219 K 2219 K * 1319 K * 2319 K		106	159	2	0.17	5.8	3.7	3.9	3.21
		106	159	2	0.27	3.7	2.4	2.5	3.87
		108	187	2.5	0.23	4.3	2.8	2.9	6.84
		108	187	2.5	0.38	2.6	1.7	1.8	9.01
1220 K 2220 K * 1320 K * 2320 K		111	169	2	0.17	5.6	3.6	3.8	3.82
		111	169	2	0.27	3.7	2.4	2.5	4.53
		113	202	2.5	0.24	4.1	2.7	2.8	8.46
		113	202	2.5	0.38	2.6	1.7	1.8	11.6
— — — —		116	179	2	0.18	5.5	3.6	3.7	4.52
		116	179	2	0.28	3.5	2.3	2.4	5.64
		118	212	2.5	0.23	4.2	2.7	2.9	10
		118	212	2.5	0.38	2.6	1.7	1.7	14.4
1222 K * 2222 K * 1322 K * 2322 K		121	189	2	0.17	5.7	3.7	3.9	5.33
		121	189	2	0.28	3.5	2.2	2.3	6.64
		123	227	2.5	0.22	4.4	2.8	3.0	12
		123	227	2.5	0.37	2.6	1.7	1.8	17.4

Notes <sup>(1)</sup> The suffix K represents bearings with tapered bores (1 : 12)

(\*) The balls of the bearings marked \* protrude slightly from the bearing face. The protrusion amounts are shown on Page B73.

Remarks For the dimensions related to adapters, refer to Pages B356 and B357.

## CYLINDRICAL ROLLER BEARINGS

### SINGLE-ROW CYLINDRICAL ROLLER BEARINGS

Bore Diameter 20~ 65mm .....Pages B 84~B 89

Bore Diameter 70~160mm .....Pages B 90~B 97

Bore Diameter 170~500mm .....Pages B 98~B101

### L-SHAPED THRUST COLLARS FOR CYLINDRICAL ROLLER BEARINGS

Bore Diameter 20~320mm .....Pages B102~B105

### DOUBLE-ROW CYLINDRICAL ROLLER BEARINGS

Bore Diameter 25~360mm .....Pages B106~B109

Four-Row Cylindrical Roller Bearings are described on Pages B294 to B303.

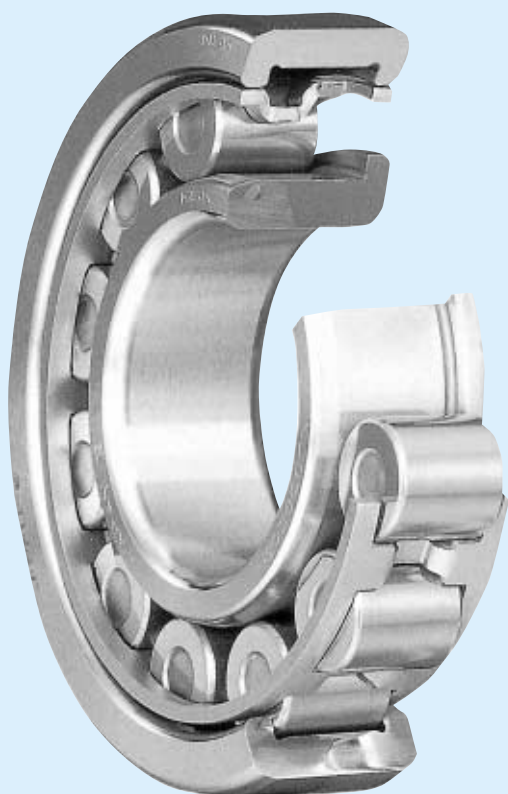

### DESIGN, TYPES, AND FEATURES

Depending on the existence of ribs on their rings, Cylindrical Roller Bearings are classified into the following types.

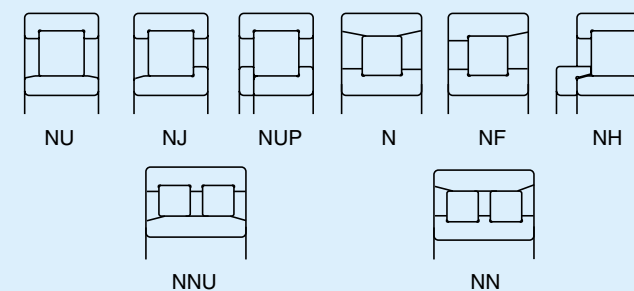

Types NU, N, NNU, and NN are suitable as free-end bearings. Types NJ and NF can sustain limited axial loads in one direction. Types NH and NUP can be used as fixed-end bearings.

NH-type cylindrical roller bearings consist of the NJ-type cylindrical roller bearings and HJ-type L-shaped thrust collars (See Page B102 to B105).

The inner ring loose rib of a NUP-type cylindrical roller bearing should be mounted so that the marked side is on the outside.



Use pressed, machined, or molded cages for standard cylindrical roller bearings as shown in Table 1.

**Table 1 Standard Cages for Cylindrical Roller Bearings**

Series	Pressed Steel Cages (W)	Machined Brass Cages (M)	Molded Polyamide Cages (T)
NU10**	—	1005~10/500	—
N2**	204~230	232~264	—
NU2**	228~230	232~264	—
NU2**E	205E~213E	214E~240E	204E
NU22**	2204~2230	2232~2252	—
NU22**E	—	2222E~2240E	2204E~2220E
N3**	304~330	332~352	—
NU3**	312~330	332~352	—
NU3**E	305E~311E	312E~340E	304E
NU23**	2304~2320	2322~2340	—
NU23**E	—	2322E~2340E	2304E~2320E
NU4**	405~416	417~430	—

The basic load ratings listed in the bearing tables are based on the Cage Classification in Table 1.

For a given bearing number, if the type of cage is not the standard one, the number of rollers may vary; in such a case, the load rating will differ from the one listed in the bearing tables.

Among the NN Type of double-row bearings, there are many of high precision that have tapered bores, and they are primarily used in the main spindles of machine tools. Their cages are either molded polyphenylenesulfide (PPS) or machined brass.

**PRECAUTIONS FOR USE OF CYLINDRICAL ROLLER BEARINGS**

If the load on cylindrical roller bearings becomes too small during operation, slippage between the rollers and raceways occurs, which may result in smearing. Especially with large bearings since the weight of the roller and cage is high.

In case of strong shock loads or vibration, pressed-steel cages are sometimes inadequate.

If very small bearing load or strong shock loads or vibration are expected, please consult with NSK for selection of the bearings.

Bearings with molded polyamide cages (ET type) can be used continuously at temperatures between -40 and 120°C. If the bearings are used in gear oil, nonflammable hydraulic oil, or ester oil at a high temperature over 100°C, please contact NSK beforehand.

**TOLERANCES AND RUNNING ACCURACY**

**CYLINDRICAL ROLLER BEARINGS** .....Table 8.2 (Pages A60~A63)

**DOUBLE-ROW CYLINDRICAL ROLLER BEARINGS** .....Table 8.2 (Pages A60~A63)

**Table 2 Tolerances for Roller Inscribed Circle Diameter  $F_w$  and Roller Circumscribed Circle Diameter  $E_w$  of Cylindrical Roller Bearings Having Interchangeable Rings** Units :  $\mu\text{m}$

Nominal Bore Diameter $d$ (mm)	Tolerances for $F_w$ of types NU, NJ, NUP, NH, and NNU $\Delta F_w$	Tolerances for $E_w$ of types N, NF, and NN $\Delta E_w$	
		high	low
over	incl	high	low
—	20	+10	0
20	50	+15	0
50	120	+20	0
120	200	+25	0
200	250	+30	0
250	315	+35	0
315	400	+40	0
400	500	+45	0

**RECOMMENDED FITS**

**CYLINDRICAL ROLLER BEARINGS** .....Table 9.2 (Page A84)  
Table 9.4 (Page A85)

**DOUBLE-ROW CYLINDRICAL ROLLER BEARINGS** .....Table 9.2 (Page A84)  
Table 9.4 (Page A85)

**INTERNAL CLEARANCES**

**CYLINDRICAL ROLLER BEARINGS** .....Table 9.14 (Page A91)  
**DOUBLE-ROW CYLINDRICAL ROLLER BEARINGS** .....Table 9.14 (Page A91)

**PERMISSIBLE MISALIGNMENT**

The permissible misalignment of cylindrical roller bearings varies depending on the type and internal specifications, but under normal loads, the angles are approximately as follows:

- Cylindrical Roller Bearings of width series 0 or 1 .....0.0012 radian (4')
  - Cylindrical Roller Bearings of width series 2 .....0.0006 radian (2')
- For double-row cylindrical roller bearings, nearly no misalignment is allowed.

**LIMITING SPEEDS**

The limiting speeds listed in the bearing tables should be adjusted depending on the bearing load conditions. Also, higher speeds are attainable by making changes in the lubrication method, cage design, etc. Refer to Page A37 for detailed information.

Bore Diameter 20~35 mm

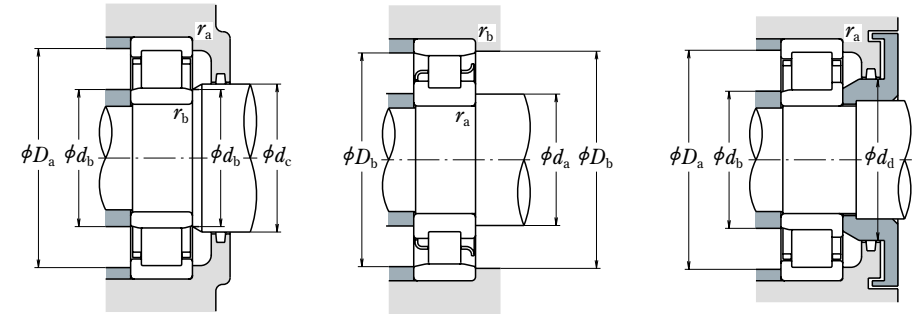
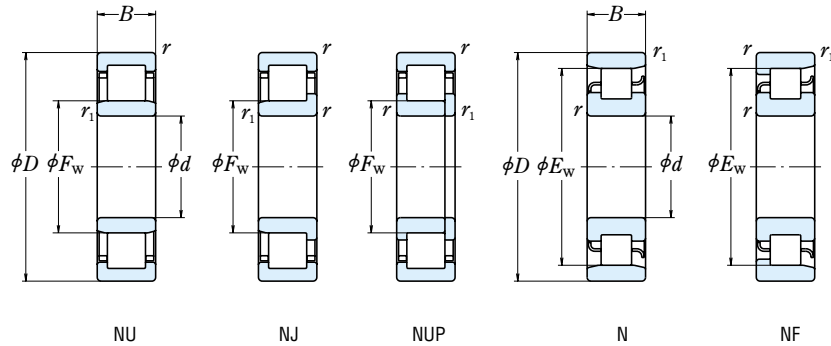

d	Boundary Dimensions (mm)						Basic Load Ratings (N)		Limiting Speeds <sup>(1)</sup> (rpm)	
	D	B	r min	r <sub>1</sub> min	F <sub>w</sub>	E <sub>w</sub>	C <sub>r</sub>	C <sub>0r</sub>	Grease	Oil
20	47	14	1	0.6	—	40	15 400	12 700	15 000	18 000
	47	14	1	0.6	26.5	—	25 700	22 600	13 000	16 000
	47	18	1	0.6	27	—	20 700	18 400	13 000	16 000
	47	18	1	0.6	26.5	—	30 500	28 300	13 000	16 000
	52	15	1.1	0.6	—	44.5	21 400	17 300	12 000	15 000
	52	15	1.1	0.6	27.5	—	31 500	26 900	12 000	15 000
25	52	21	1.1	0.6	28.5	—	30 500	27 200	11 000	14 000
	52	21	1.1	0.6	27.5	—	42 000	39 000	11 000	14 000
	47	12	0.6	0.3	30.5	—	14 300	13 100	15 000	18 000
	52	15	1	0.6	—	45	17 700	15 700	13 000	16 000
	52	15	1	0.6	31.5	—	29 300	27 700	12 000	14 000
	52	18	1	0.6	31.5	—	35 000	34 500	12 000	14 000
30	62	17	1.1	1.1	—	53	29 300	25 200	10 000	13 000
	62	17	1.1	1.1	34	—	41 500	37 500	10 000	12 000
	62	24	1.1	1.1	34	—	57 000	56 000	9 000	11 000
	80	21	1.5	1.5	38.8	62.8	46 500	40 000	9 000	11 000
	55	13	1	0.6	36.5	48.5	19 700	19 600	12 000	15 000
	62	16	1	0.6	—	53.5	24 900	23 300	11 000	13 000
35	62	16	1	0.6	37.5	—	39 000	37 500	9 500	12 000
	62	20	1	0.6	37.5	—	49 000	50 000	9 500	12 000
	72	19	1.1	1.1	—	62	38 500	35 000	8 500	11 000
	72	19	1.1	1.1	40.5	—	53 000	50 000	8 500	10 000
	72	27	1.1	1.1	40.5	—	74 500	77 500	8 000	9 500
	90	23	1.5	1.5	45	73	62 500	55 000	7 500	9 500
100	62	14	1	0.6	42	55	22 600	23 200	11 000	13 000
	72	17	1.1	0.6	—	61.8	35 500	34 000	9 500	11 000
	72	17	1.1	0.6	44	—	50 500	50 000	8 500	10 000
	72	23	1.1	0.6	44	—	61 500	65 000	8 500	10 000
	80	21	1.5	1.1	—	68.2	49 500	47 000	8 000	9 500
	80	21	1.5	1.1	46.2	—	66 500	65 500	7 500	9 500

Bearing Numbers <sup>(2)</sup>	Abutment and Fillet Dimensions (mm)										Mass (kg) approx						
	NU	NJ	NUP	N	NF	d <sub>a</sub> <sup>(4)</sup> min	d <sub>b</sub> min	d <sub>b</sub> <sup>(5)</sup> max	d <sub>c</sub> min	d <sub>d</sub> min		D <sub>a</sub> <sup>(4)</sup> max	D <sub>b</sub> max	D <sub>b</sub> min	r <sub>a</sub> max	r <sub>b</sub> max	
<b>N 204</b>	—	—	—	<b>N</b>	<b>NF</b>	25	—	—	—	—	—	43	42	1	0.6	0.107	
<b>NU 204 ET</b>	<b>NU</b>	<b>NJ</b>	<b>NUP</b>	—	—	25	24	25	29	32	42	—	—	1	0.6	0.107	
<b>NU2204</b>	<b>NU</b>	<b>NJ</b>	—	—	—	25	24	25	29	32	42	—	—	1	0.6	0.144	
<b>NU2204 ET</b>	<b>NU</b>	<b>NJ</b>	<b>NUP</b>	—	—	25	24	25	29	32	42	—	—	1	0.6	0.138	
<b>N 304</b>	—	—	—	<b>N</b>	<b>NF</b>	26.5	—	—	—	—	—	48	46	1	0.6	0.148	
<b>NU 304 ET</b>	<b>NU</b>	<b>NJ</b>	<b>NUP</b>	—	—	26.5	24	26	30	33	45.5	—	—	1	0.6	0.145	
<b>NU2304</b>	<b>NU</b>	<b>NJ</b>	<b>NUP</b>	—	—	26.5	24	27	30	33	45.5	—	—	1	0.6	0.217	
<b>NU2304 ET</b>	<b>NU</b>	<b>NJ</b>	<b>NUP</b>	—	—	26.5	24	26	30	33	45.5	—	—	1	0.6	0.209	
<b>NU1005</b>	<b>NU</b>	—	—	—	—	—	27	30	32	—	43	—	—	0.6	0.3	0.094	
<b>N 205</b>	—	—	—	<b>N</b>	<b>NF</b>	30	—	—	—	—	—	48	46	1	0.6	0.135	
<b>NU 205 EW</b>	<b>NU</b>	<b>NJ</b>	<b>NUP</b>	—	—	30	29	30	34	37	47	—	—	1	0.6	0.136	
<b>NU2205 ET</b>	<b>NU</b>	<b>NJ</b>	<b>NUP</b>	—	—	30	29	30	34	37	47	—	—	1	0.6	0.16	
<b>N 305</b>	—	—	—	<b>N</b>	<b>NF</b>	31.5	—	—	—	—	—	55.5	50	1	1	0.233	
<b>NU 305 EW</b>	<b>NU</b>	<b>NJ</b>	<b>NUP</b>	—	—	31.5	31.5	32	37	40	55.5	—	—	1	1	0.269	
<b>NU2305 ET</b>	<b>NU</b>	<b>NJ</b>	<b>NUP</b>	—	—	31.5	31.5	32	37	40	55.5	—	—	1	1	0.338	
<b>NU 405</b>	<b>NU</b>	<b>NJ</b>	—	<b>N</b>	<b>NF</b>	33	33	37	41	46	72	72	64	1.5	1.5	0.57	
<b>NU1006</b>	<b>NU</b>	—	—	<b>N</b>	—	—	35	34	36	38	—	50	51	49	1	0.5	0.136
<b>N 206</b>	—	—	—	<b>N</b>	<b>NF</b>	35	—	—	—	—	—	58	56	1	0.6	0.208	
<b>NU 206 EW</b>	<b>NU</b>	<b>NJ</b>	<b>NUP</b>	—	—	35	34	36	40	44	57	—	—	1	0.6	0.205	
<b>NU2206 ET</b>	<b>NU</b>	<b>NJ</b>	<b>NUP</b>	—	—	35	34	36	40	44	57	—	—	1	0.6	0.255	
<b>N 306</b>	—	—	—	<b>N</b>	<b>NF</b>	36.5	—	—	—	—	—	65.5	64	1	1	0.353	
<b>NU 306 EW</b>	<b>NU</b>	<b>NJ</b>	<b>NUP</b>	—	—	36.5	36.5	39	44	48	65.5	—	—	1	1	0.409	
<b>NU2306 ET</b>	<b>NU</b>	<b>NJ</b>	<b>NUP</b>	—	—	36.5	36.5	39	44	48	65.5	—	—	1	1	0.518	
<b>NU 406</b>	<b>NU</b>	<b>NJ</b>	—	<b>N</b>	<b>NF</b>	38	38	43	47	52	82	82	75	1.5	1.5	0.758	
<b>NU1007</b>	<b>NU</b>	<b>NJ</b>	—	<b>N</b>	—	—	40	39	41	44	—	57	58	56	1	0.5	0.18
<b>N 207</b>	—	—	—	<b>N</b>	<b>NF</b>	41.5	—	—	—	—	—	68	64	1	0.6	0.301	
<b>NU 207 EW</b>	<b>NU</b>	<b>NJ</b>	<b>NUP</b>	—	—	41.5	39	42	46	50	65.5	—	—	1	0.6	0.304	
<b>NU2207 ET</b>	<b>NU</b>	<b>NJ</b>	<b>NUP</b>	—	—	41.5	39	42	46	50	65.5	—	—	1	0.6	0.40	
<b>N 307</b>	—	—	—	<b>N</b>	<b>NF</b>	43	—	—	—	—	—	73.5	70	1.5	1	0.476	
<b>NU 307 EW</b>	<b>NU</b>	<b>NJ</b>	<b>NUP</b>	—	—	41.5	41.5	44	48	53	72	—	—	1.5	1	0.545	
<b>NU2307 ET</b>	<b>NU</b>	<b>NJ</b>	<b>NUP</b>	—	—	43	41.5	44	48	53	72	—	—	1.5	1	0.711	
<b>NU 407</b>	<b>NU</b>	<b>NJ</b>	—	<b>N</b>	<b>NF</b>	43	43	51	55	61	92	92	85	1.5	1.5	1.01	

**Notes** <sup>(1)</sup> The limiting speeds listed above apply to bearings with machined cages (No suffix). For bearings with pressed cages, reduce the limiting speed by 20%. (Not applicable to bearing numbers with an EM, EW, or ET suffix.)  
<sup>(2)</sup> The bearings with suffix ET have polyamide cage. The maximum operating temperature should be less than 120 °C.

**Notes** <sup>(3)</sup> When L-shaped thrust collars (See section for L-Shaped Thrust Collars starting on page B100) are used, the bearings become the NH type.  
<sup>(4)</sup> If axial loads are applied, increase d<sub>a</sub> and reduce D<sub>a</sub> from the values listed above.  
<sup>(5)</sup> d<sub>b</sub> (max) are values for adjusting rings for NU, NJ Types.

Bore Diameter 40~55 mm

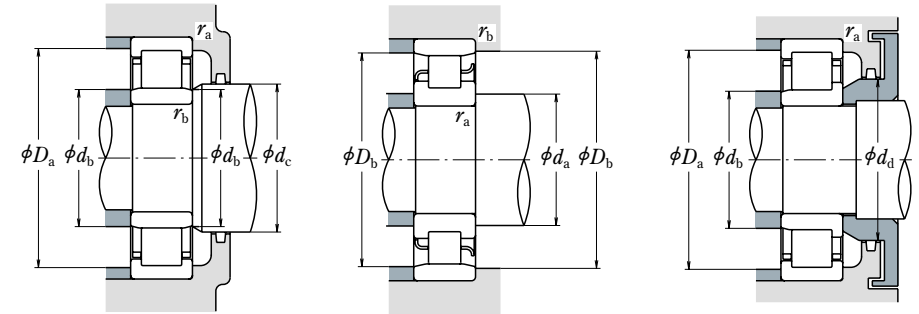
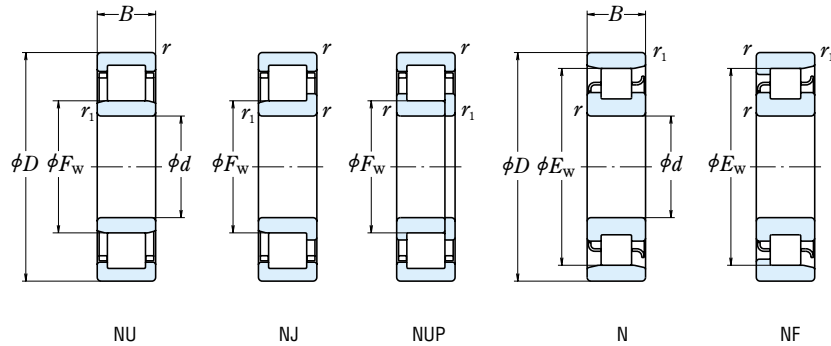

d	Boundary Dimensions (mm)						Basic Load Ratings (N)		Limiting Speeds <sup>(1)</sup> (rpm)	
	D	B	r min	r <sub>1</sub> min	F <sub>w</sub>	E <sub>w</sub>	C <sub>r</sub>	C <sub>0r</sub>	Grease	Oil
40	68	15	1	0.6	47	61	27 300	29 000	10 000	12 000
	80	18	1.1	1.1	—	70	43 500	43 000	8 500	10 000
	80	18	1.1	1.1	49.5	—	55 500	55 500	7 500	9 000
	80	23	1.1	1.1	49.5	—	72 500	77 500	7 500	9 000
	90	23	1.5	1.5	—	77.5	58 500	57 000	6 700	8 500
45	90	23	1.5	1.5	52	—	83 000	81 500	6 700	8 000
	90	33	1.5	1.5	52	—	114 000	122 000	6 000	7 500
	110	27	2	2	58	92	95 500	89 000	6 000	7 500
	75	16	1	0.6	52.5	67.5	32 500	35 500	9 000	11 000
	85	19	1.1	1.1	—	75	46 000	47 000	7 500	9 000
50	85	19	1.1	1.1	54.5	—	63 000	66 500	6 700	8 000
	85	23	1.1	1.1	54.5	—	76 000	84 500	6 700	8 500
	100	25	1.5	1.5	—	86.5	74 000	71 000	6 300	7 500
	100	25	1.5	1.5	58.5	—	97 500	98 500	6 000	7 500
	100	36	1.5	1.5	58.5	—	137 000	153 000	5 300	6 700
55	120	29	2	2	64.5	100.5	107 000	102 000	5 600	6 700
	80	16	1	0.6	57.5	72.5	32 000	36 000	8 000	10 000
	90	20	1.1	1.1	—	80.4	48 000	51 000	7 100	8 500
	90	20	1.1	1.1	59.5	—	69 000	76 500	6 300	7 500
	90	23	1.1	1.1	59.5	—	83 500	97 000	6 300	8 000

Bearing Numbers <sup>(2)</sup>						Abutment and Fillet Dimensions (mm)								Mass (kg) approx	
<sup>(3)</sup> NU NJ NUP N NF						d <sub>a</sub> <sup>(4)</sup> min	d <sub>b</sub> min	d <sub>b</sub> <sup>(5)</sup> max	d <sub>c</sub> min	d <sub>d</sub> min	D <sub>a</sub> <sup>(4)</sup> max	D <sub>b</sub> max	D <sub>b</sub> min		r <sub>a</sub> max
NU1008	NU	NJ	NUP	N	—	45	44	46	49	—	63	64	62	1	0.6
N 208	—	—	—	N	NF	46.5	—	—	—	—	—	73.5	72	1	1
NU 208 EW	NU	NJ	NUP	—	—	46.5	46.5	48	52	56	73.5	—	—	1	1
NU2208 ET	NU	NJ	NUP	—	—	46.5	46.5	48	52	56	73.5	—	—	1	1
N 308	—	—	—	N	NF	48	—	—	—	—	—	82	79	1.5	1.5
NU 308 EW	NU	NJ	NUP	—	—	48	48	50	55	60	82	—	—	1.5	1.5
NU2308 ET	NU	NJ	NUP	—	—	48	48	50	55	60	82	—	—	1.5	1.5
NU 408	NU	NJ	NUP	N	NF	49	49	56	60	67	101	101	94	2	2
NU1009	NU	—	—	N	NF	50	49	51	54	—	70	71	68	1	0.6
N 209	—	—	—	N	NF	51.5	—	—	—	—	—	78.5	77	1	1
NU 209 EW	NU	NJ	NUP	—	—	51.5	51.5	52	57	61	78.5	—	—	1	1
NU2209 ET	NU	NJ	NUP	—	—	51.5	51.5	52	57	61	78.5	—	—	1	1
N 309	—	—	—	N	NF	53	—	—	—	—	—	92	77	1.5	1.5
NU 309 EW	NU	NJ	NUP	—	—	53	53	56	60	66	92	—	—	1.5	1.5
NU2309 ET	NU	NJ	NUP	—	—	53	53	56	60	66	92	—	—	1.5	1.5
NU 409	NU	NJ	NUP	N	NF	54	54	62	66	74	111	111	103	2	2
NU1010	NU	NJ	NUP	N	—	55	54	56	59	—	75	76	73	1	0.6
N 210	—	—	—	N	NF	56.5	—	—	—	—	—	83.5	82	1	1
NU 210 EW	NU	NJ	NUP	—	—	56.5	56.5	57	62	67	83.5	—	—	1	1
NU2210 ET	NU	NJ	NUP	—	—	56.5	56.5	57	62	67	83.5	—	—	1	1
N 310	—	—	—	N	NF	59	—	—	—	—	—	101	97	2	2
NU 310 EW	NU	NJ	NUP	—	—	59	59	63	67	73	101	—	—	2	2
NU2310 ET	NU	NJ	NUP	—	—	59	59	63	67	73	101	—	—	2	2
NU 410	NU	NJ	NUP	N	NF	61	61	68	73	81	119	119	113.3	2	2
NU1011	NU	NJ	—	N	—	61.5	60	63	66	—	83.5	85	82	1	1
N 211	—	—	—	N	NF	63	—	—	—	—	—	93.5	91	1.5	1
NU 211 EW	NU	NJ	NUP	—	—	63	61.5	64	68	73	92	—	—	1.5	1
NU2211 ET	NU	NJ	NUP	—	—	63	61.5	64	68	73	92	—	—	1.5	1
N 311	—	—	—	N	NF	64	—	—	—	—	—	111	107	2	2
NU 311 EW	NU	NJ	NUP	—	—	64	64	68	72	80	111	—	—	2	2
NU2311 ET	NU	NJ	NUP	—	—	64	64	68	72	80	111	—	—	2	2
NU 411	NU	NJ	NUP	N	NF	66	66	75	79	87	129	129	119	2	2

Notes <sup>(1)</sup> The limiting speeds listed above apply to bearings with machined cages (No suffix). For bearings with pressed cages, reduce the limiting speed by 20%. (Not applicable to bearing numbers with an EM, EW, or ET suffix.)  
<sup>(2)</sup> The bearings with suffix ET have polyamide cage. The maximum operating temperature should be less than 120 °C.

Notes <sup>(3)</sup> When L-shaped thrust collars (See section for L-Shaped Thrust Collars starting on page B100) are used, the bearings become the NH type.  
<sup>(4)</sup> If axial loads are applied, increase d<sub>a</sub> and reduce D<sub>a</sub> from the values listed above.  
<sup>(5)</sup> d<sub>b</sub> (max) are values for adjusting rings for NU, NJ Types.

Bore Diameter 60~75 mm

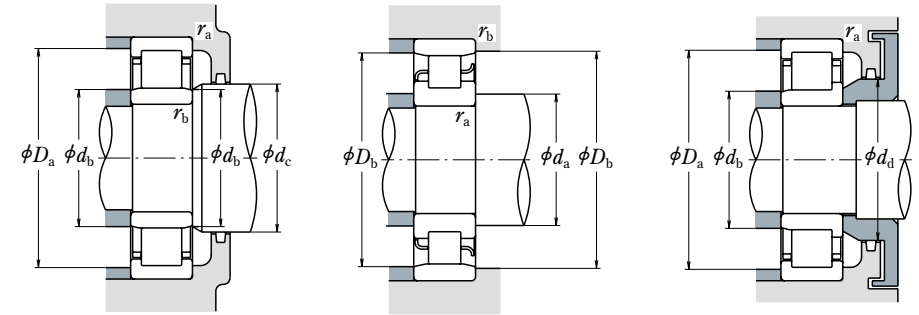
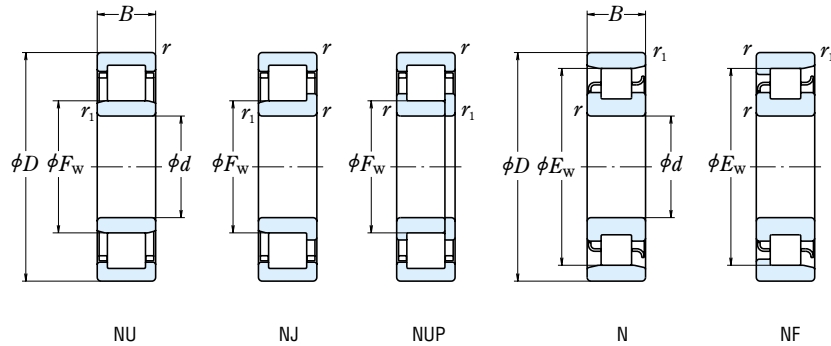

d	Boundary Dimensions (mm)						Basic Load Ratings (N)		Limiting Speeds <sup>(1)</sup> (rpm)	
	D	B	r <sub>min</sub>	r <sub>1min</sub>	F <sub>w</sub>	E <sub>w</sub>	C <sub>r</sub>	C <sub>0r</sub>	Grease	Oil
60	95	18	1.1	1	69.5	85.5	40 000	48 500	6 700	8 500
	110	22	1.5	1.5	—	97.5	68 500	75 000	6 000	7 100
	110	22	1.5	1.5	72	—	97 500	107 000	5 300	6 300
	110	28	1.5	1.5	72	—	131 000	157 000	5 300	6 300
	130	31	2.1	2.1	—	113	124 000	126 000	4 800	5 600
	130	31	2.1	2.1	77	—	124 000	126 000	4 800	5 600
	130	31	2.1	2.1	77	—	150 000	157 000	4 800	5 600
	130	46	2.1	2.1	77	—	222 000	262 000	4 300	5 300
	150	35	2.1	2.1	83	127	167 000	168 000	4 300	5 300
	65	100	18	1.1	1	74.5	90.5	41 000	51 000	6 300
120		23	1.5	1.5	—	105.6	84 000	94 500	5 300	6 300
120		23	1.5	1.5	78.5	—	108 000	119 000	4 800	5 600
120		31	1.5	1.5	78.5	—	149 000	181 000	4 800	6 000
140		33	2.1	2.1	—	121.5	135 000	139 000	4 300	5 300
140		33	2.1	2.1	83.5	—	135 000	139 000	4 300	5 300
140		33	2.1	2.1	82.5	—	181 000	191 000	4 300	5 300
140		48	2.1	2.1	82.5	—	233 000	265 000	3 800	4 800
160		37	2.1	2.1	89.3	135.3	182 000	186 000	4 000	4 800
70		110	20	1.1	1	80	100	58 500	70 500	6 000
	125	24	1.5	1.5	—	110.5	83 500	95 000	5 000	6 300
	125	24	1.5	1.5	83.5	—	119 000	137 000	5 000	6 300
	125	31	1.5	1.5	83.5	—	156 000	194 000	4 500	5 600
	150	35	2.1	2.1	—	130	158 000	168 000	4 000	5 000
	150	35	2.1	2.1	90	—	158 000	168 000	4 000	5 000
	150	35	2.1	2.1	89	—	205 000	222 000	4 000	5 000
	150	51	2.1	2.1	89	—	274 000	325 000	3 600	4 500
	180	42	3	3	100	152	228 000	236 000	3 600	4 300
	75	115	20	1.1	1	85	105	60 000	74 500	5 600
130		25	1.5	1.5	—	116.5	96 500	111 000	4 800	6 000
130		25	1.5	1.5	88.5	—	130 000	156 000	4 800	6 000
130		31	1.5	1.5	88.5	—	162 000	207 000	4 300	5 300
160		37	2.1	2.1	—	139.5	179 000	189 000	3 800	4 800
160		37	2.1	2.1	95.5	—	179 000	189 000	3 800	4 800
160		37	2.1	2.1	95	—	240 000	263 000	3 800	4 800
160		55	2.1	2.1	95	—	330 000	395 000	3 400	4 300
190		45	3	3	104.5	160.5	262 000	274 000	3 400	4 000

Bearing Numbers <sup>(2)</sup>						Abutment and Fillet Dimensions (mm)								Mass (kg) approx		
NU	NJ	NUP	N	NF		d <sub>a</sub> <sup>(4)</sup> min	d <sub>b</sub> min	d <sub>b</sub> <sup>(5)</sup> max	d <sub>c</sub> min	d <sub>d</sub> min	D <sub>a</sub> <sup>(4)</sup> max	D <sub>b</sub> max	D <sub>b</sub> min		r <sub>a</sub> max	r <sub>b</sub> max
NU1012	NU NJ	—	N	NF		66.5	65	68	71	—	88.5	90	87	1	1	0.474
N 212	—	—	N	NF		68	—	—	—	—	—	102	100	1.5	1.5	0.823
NU 212 EW	NU NJ	NUP	—	—		68	68	70	75	80	102	—	—	1.5	1.5	0.824
NU2212 ET	NU NJ	NUP	—	—		68	68	70	75	80	102	—	—	1.5	1.5	1.06
N 312	—	—	N	NF		71	—	—	—	—	—	119	115	2	2	1.78
NU 312	NU NJ	NUP	—	—		71	71	75	79	86	119	—	—	2	2	1.82
NU 312 EM	NU NJ	NUP	—	—		71	71	75	79	86	119	—	—	2	2	2.06
NU2312 ET	NU NJ	NUP	—	—		71	71	75	79	86	119	—	—	2	2	2.7
NU 412	NU NJ	NUP	N	NF		71	71	80	85	94	139	139	130	2	2	3.04
NU1013	NU NJ	—	N	NF		71.5	70	73	76	—	93.5	95	92	1	1	0.504
N 213	—	—	N	NF		73	—	—	—	—	—	112	108	1.5	1.5	1.05
NU 213 EW	NU NJ	NUP	—	—		73	73	76	81	87	112	—	—	1.5	1.5	1.05
NU2213 ET	NU NJ	NUP	—	—		73	73	76	81	87	112	—	—	1.5	1.5	1.41
N 313	—	—	N	NF		76	—	—	—	—	—	129	125	2	2	2.17
NU 313	NU NJ	NUP	—	—		76	76	81	85	93	129	—	—	2	2	2.23
NU 313 EM	NU NJ	NUP	—	—		76	76	80	85	93	129	—	—	2	2	2.56
NU2313 ET	NU NJ	NUP	—	—		76	76	80	85	93	129	—	—	2	2	3.16
NU 413	NU NJ	—	N	NF		76	76	86	91	100	149	149	138.8	2	2	3.63
NU1014	NU NJ	NUP	N	NF		76.5	75	79	82	—	103.5	105	101	1	1	0.693
N 214	—	—	N	NF		78	—	—	—	—	—	117	113	1.5	1.5	1.14
NU 214 EM	NU NJ	NUP	—	—		78	78	81	86	92	117	—	—	1.5	1.5	1.29
NU2214 ET	NU NJ	NUP	—	—		78	78	81	86	92	117	—	—	1.5	1.5	1.49
N 314	—	—	N	NF		81	—	—	—	—	—	139	133.5	2	2	2.67
NU 314	NU NJ	NUP	—	—		81	81	87	92	100	139	—	—	2	2	2.75
NU 314 EM	NU NJ	NUP	—	—		81	81	86	92	100	139	—	—	2	2	3.09
NU2314 ET	NU NJ	NUP	—	—		81	81	86	92	100	139	—	—	2	2	3.92
NU 414	NU NJ	NUP	N	NF		83	83	97	102	112	167	167	155	2.5	2.5	5.28
NU1015	NU	—	N	NF		81.5	80	83	87	—	108.5	110	106	1	1	0.731
N 215	—	—	N	NF		83	—	—	—	—	—	122	119	1.5	1.5	1.23
NU 215 EM	NU NJ	NUP	—	—		83	83	86	90	96	122	—	—	1.5	1.5	1.44
NU2215 ET	NU NJ	NUP	—	—		83	83	86	90	96	122	—	—	1.5	1.5	1.57
N 315	—	—	N	NF		86	—	—	—	—	—	149	143	2	2	3.2
NU 315	NU NJ	NUP	—	—		86	86	93	97	106	149	—	—	2	2	3.26
NU 315 EM	NU NJ	NUP	—	—		86	86	92	97	106	149	—	—	2	2	3.73
NU2315 ET	NU NJ	NUP	—	—		86	86	92	97	106	149	—	—	2	2	4.86
NU 415	NU NJ	—	N	NF		88	88	102	107	118	177	177	164	2.5	2.5	6.27

**Notes** <sup>(1)</sup> The limiting speeds listed above apply to bearings with machined cages (No suffix). For bearings with pressed cages, reduce the limiting speed by 20%. (Not applicable to bearing numbers with an EM, EW, or ET suffix.)

<sup>(2)</sup> The bearings with suffix ET have polyamide cage. The maximum operating temperature should be less than 120 °C.

**Notes** <sup>(3)</sup> When L-shaped thrust collars (See section for L-Shaped Thrust Collars starting on page B100) are used, the bearings become the NH type.

<sup>(4)</sup> If axial loads are applied, increase d<sub>a</sub> and reduce D<sub>a</sub> from the values listed above.

<sup>(5)</sup> d<sub>b</sub> (max) are values for adjusting rings for NU, NJ Types.

Bore Diameter 80~95 mm

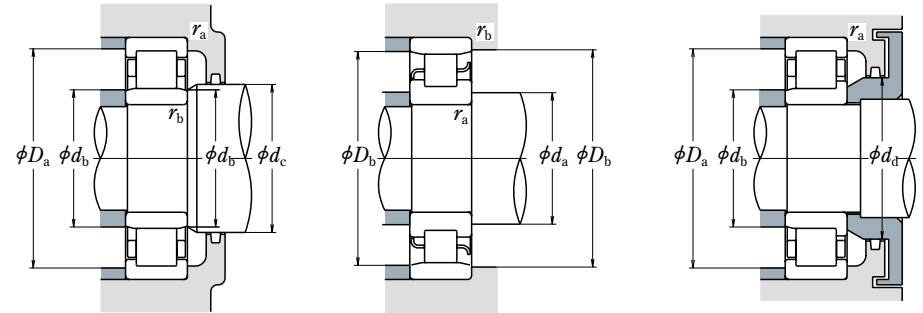
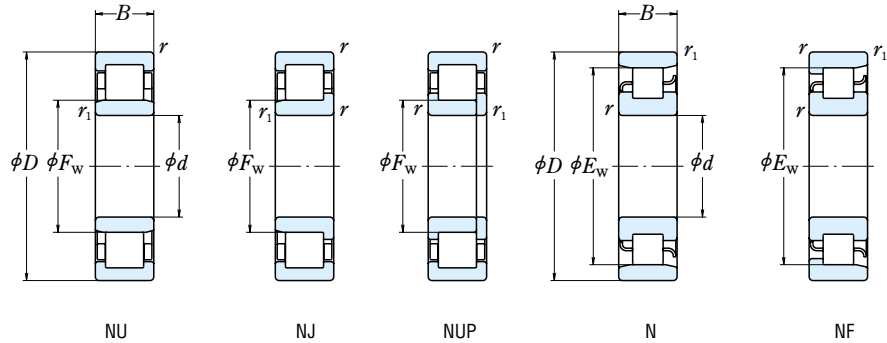

d	Boundary Dimensions (mm)						Basic Load Ratings (N)		Limiting Speeds <sup>(1)</sup> (rpm)		
	D	B	r <sub>min</sub>	r <sub>1min</sub>	F <sub>w</sub>	E <sub>w</sub>	C <sub>r</sub>	C <sub>0r</sub>	Grease	Oil	
80	125	22	1.1	1	91.5	113.5	72 500	90 500	5 300	6 300	
	140	26	2	2	—	125.3	106 000	122 000	4 500	5 300	
	140	26	2	2	95.3	—	139 000	167 000	4 500	5 300	
	140	33	2	2	95.3	—	186 000	243 000	4 000	5 000	
	170	39	2.1	2.1	—	147	190 000	207 000	3 600	4 300	
	170	39	2.1	2.1	101	—	256 000	282 000	3 600	4 300	
	170	58	2.1	2.1	101	—	355 000	430 000	3 200	4 000	
	200	48	3	3	110	170	299 000	315 000	3 200	3 800	
	85	130	22	1.1	1	96.5	118.5	74 500	95 500	5 000	6 000
		150	28	2	2	—	133.8	120 000	140 000	4 300	5 000
150		28	2	2	100.5	—	167 000	199 000	4 300	5 000	
150		36	2	2	100.5	—	217 000	279 000	3 800	4 500	
180		41	3	3	—	156	212 000	228 000	3 400	4 000	
180		41	3	3	108	—	212 000	228 000	3 400	4 000	
180		41	3	3	108	—	291 000	330 000	3 400	4 000	
180		60	3	3	108	—	395 000	485 000	3 000	3 800	
210		52	4	4	113	177	335 000	350 000	3 000	3 800	
90		140	24	1.5	1.1	103	127	88 000	114 000	4 500	5 600
	160	30	2	2	—	143	152 000	178 000	4 000	4 800	
	160	30	2	2	107	—	182 000	217 000	4 000	4 800	
	160	40	2	2	107	—	242 000	315 000	3 600	4 300	
	190	43	3	3	—	165	240 000	265 000	3 200	3 800	
	190	43	3	3	113.5	—	240 000	265 000	3 200	3 800	
	190	43	3	3	113.5	—	315 000	355 000	3 200	3 800	
	190	64	3	3	113.5	—	435 000	535 000	2 800	3 400	
	225	54	4	4	123.5	191.5	375 000	400 000	2 800	3 400	
	95	145	24	1.5	1.1	108	132	90 500	120 000	4 300	5 300
170		32	2.1	2.1	—	151.5	158 000	183 000	3 800	4 500	
170		32	2.1	2.1	112.5	—	220 000	265 000	3 800	4 500	
170		43	2.1	2.1	112.5	—	273 000	350 000	3 400	4 000	
200		45	3	3	—	173.5	259 000	289 000	3 000	3 600	
200		45	3	3	121.5	—	259 000	289 000	3 000	3 600	
200		45	3	3	121.5	—	335 000	385 000	3 000	3 600	
200		67	3	3	121.5	—	460 000	585 000	2 600	3 400	
240		55	4	4	133.5	201.5	400 000	445 000	2 600	3 200	

Bearing Numbers <sup>(2)</sup>						Abutment and Fillet Dimensions (mm)								Mass (kg)		
<sup>(3)</sup>						d <sub>a</sub> <sup>(4)</sup>	d <sub>b</sub>	d <sub>b</sub> <sup>(5)</sup>	d <sub>c</sub>	d <sub>d</sub>	D <sub>a</sub> <sup>(4)</sup>	D <sub>b</sub>	D <sub>b</sub>	r <sub>a</sub>	r <sub>b</sub>	approx
NU	NJ	NUP	N	NF		min	min	max	min	min	max	max	min	max	max	
NU1016	—	—	N	—	—	86.5	85	90	94	—	118.5	120	115	1	1	0.969
N 216	—	—	N	NF	—	89	—	—	—	—	—	131	128	2	2	1.47
NU 216 EM	NU	NJ	NUP	—	—	89	89	92	97	104	131	—	—	2	2	1.7
NU2216 ET	NU	NJ	NUP	—	—	89	89	92	97	104	131	—	—	2	2	1.96
N 316	—	—	N	NF	—	91	—	—	—	—	—	159	150	2	2	3.85
NU 316 EM	NU	NJ	NUP	—	—	91	91	98	105	114	159	—	—	2	2	4.45
NU2316 ET	NU	NJ	NUP	—	—	91	91	98	105	114	159	—	—	2	2	5.73
NU 416	NU	NJ	—	N	NF	93	93	107	112	124	187	187	173	2.5	2.5	7.36
NU1017	NU	—	—	N	—	91.5	90	95	99	—	123.5	125	120	1	1	1.01
N 217	—	—	—	N	NF	94	—	—	—	—	—	141	137	2	2	1.87
NU 217 EM	NU	NJ	NUP	—	—	94	94	98	104	110	141	—	—	2	2	2.11
NU2217 ET	NU	NJ	NUP	—	—	94	94	98	104	110	141	—	—	2	2	2.44
N 317	—	—	—	N	NF	98	—	—	—	—	—	167	159	2.5	2.5	4.53
NU 317	NU	NJ	NUP	—	—	98	98	105	110	119	167	—	—	2.5	2.5	4.6
NU 317 EM	NU	NJ	NUP	—	—	98	98	105	110	119	167	—	—	2.5	2.5	5.26
NU2317 ET	NU	NJ	NUP	—	—	98	98	105	110	119	167	—	—	2.5	2.5	6.77
NU 417	NU	NJ	—	N	NF	101	101	110	115	128	194	194	180	3	3	9.56
NU1018	NU	—	—	N	—	98	96.5	101	106	—	132	133.5	129	1.5	1	1.35
N 218	—	—	—	N	NF	99	—	—	—	—	—	151	146	2	2	2.31
NU 218 EM	NU	NJ	NUP	—	—	99	99	104	109	116	151	—	—	2	2	2.6
NU2218 ET	NU	NJ	NUP	—	—	99	99	104	109	116	151	—	—	2	2	3.11
N 318	—	—	—	N	NF	103	—	—	—	—	—	177	168	2.5	2.5	5.31
NU 318	NU	NJ	NUP	—	—	103	103	112	117	127	177	—	—	2.5	2.5	5.38
NU 318 EM	NU	NJ	NUP	—	—	103	103	111	117	127	177	—	—	2.5	2.5	6.1
NU2318 ET	NU	NJ	NUP	—	—	103	103	111	117	127	177	—	—	2.5	2.5	7.9
NU 418	NU	NJ	—	N	NF	106	106	120	125	139	209	209	196	3	3	11.5
NU1019	NU	NJ	—	N	—	103	101.5	106	111	—	137	138.5	134	1.5	1	1.41
N 219	—	—	—	N	NF	106	—	—	—	—	—	159	155	2	2	2.79
NU 219 EM	NU	NJ	NUP	—	—	106	106	110	116	123	159	—	—	2	2	3.17
NU2219 ET	NU	NJ	NUP	—	—	106	106	110	116	123	159	—	—	2	2	3.81
N 319	—	—	—	N	NF	108	—	—	—	—	—	187	177	2.5	2.5	6.09
NU 319	NU	NJ	NUP	—	—	108	108	118	124	134	187	—	—	2.5	2.5	6.23
NU 319 EM	NU	NJ	NUP	—	—	108	108	118	124	134	187	—	—	2.5	2.5	7.13
NU2319 ET	NU	NJ	NUP	—	—	108	108	118	124	134	187	—	—	2.5	2.5	9.21
NU 419	NU	NJ	NUP	—	NF	111	111	130	136	149	224	224	206	3	3	13.6

Notes <sup>(1)</sup> The limiting speeds listed above apply to bearings with machined cages (No suffix). For bearings with pressed cages, reduce the limiting speed by 20%. (Not applicable to bearing numbers with an EM, EW, or ET suffix.)  
<sup>(2)</sup> The bearings with suffix ET have polyamide cage. The maximum operating temperature should be less than 120 °C.

Notes <sup>(3)</sup> When L-shaped thrust collars (See section for L-Shaped Thrust Collars starting on page B100) are used, the bearings become the NH type.  
<sup>(4)</sup> If axial loads are applied, increase d<sub>a</sub> and reduce D<sub>a</sub> from the values listed above.  
<sup>(5)</sup> d<sub>b</sub> (max) are values for adjusting rings for NU, NJ Types.

Bore Diameter 100~120 mm

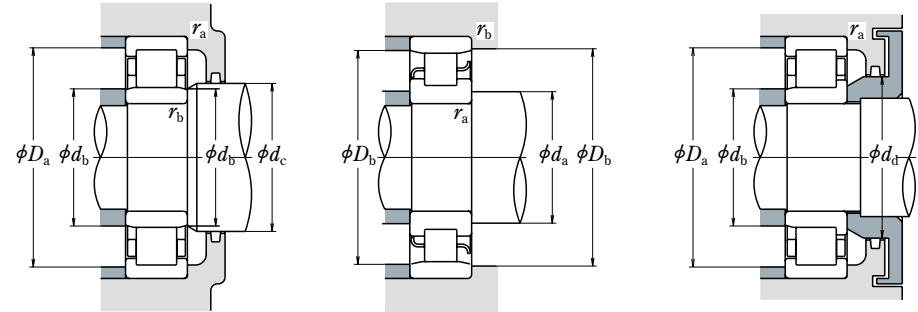
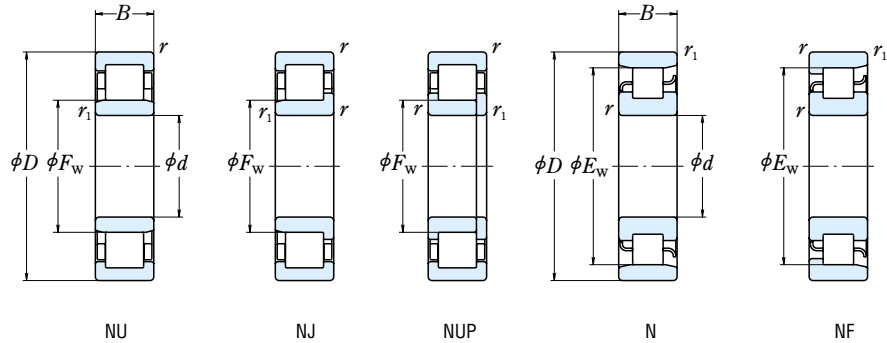

d	Boundary Dimensions (mm)						Basic Load Ratings (N)		Limiting Speeds <sup>(1)</sup> (rpm)	
	D	B	r <sub>min</sub>	r <sub>1min</sub>	F <sub>w</sub>	E <sub>w</sub>	C <sub>r</sub>	C <sub>0r</sub>	Grease	Oil
100	150	24	1.5	1.1	113	137	93 000	126 000	4 300	5 300
	180	34	2.1	2.1	—	160	183 000	217 000	3 600	4 300
	180	34	2.1	2.1	119	—	249 000	305 000	3 600	4 300
	180	46	2.1	2.1	119	—	335 000	445 000	3 200	3 800
	215	47	3	3	—	185.5	299 000	335 000	2 800	3 400
	215	47	3	3	129.5	—	299 000	335 000	2 800	3 400
	215	47	3	3	127.5	—	380 000	425 000	2 800	3 400
	215	73	3	3	127.5	—	570 000	715 000	2 400	3 000
	250	58	4	4	139	211	450 000	500 000	2 600	3 000
	105	160	26	2	1.1	119.5	145.5	109 000	149 000	4 000
190		36	2.1	2.1	—	168.8	201 000	241 000	3 400	4 000
190		36	2.1	2.1	125	—	262 000	310 000	3 400	4 000
225		49	3	3	—	195	320 000	360 000	2 600	3 200
225		49	3	3	133	—	425 000	480 000	2 600	3 200
260		60	4	4	144.5	220.5	495 000	555 000	2 400	3 000
110		170	28	2	1.1	125	155	131 000	174 000	3 800
	200	38	2.1	2.1	—	178.5	229 000	272 000	3 200	3 800
	200	38	2.1	2.1	132.5	—	293 000	365 000	3 200	3 800
	200	53	2.1	2.1	132.5	—	385 000	515 000	2 800	3 400
	240	50	3	3	—	207	360 000	400 000	2 600	3 000
	240	50	3	3	143	—	450 000	525 000	2 600	3 000
	280	65	4	4	155	—	550 000	620 000	2 200	2 800
	120	180	28	2	1.1	135	165	139 000	191 000	3 400
215		40	2.1	2.1	—	191.5	248 000	299 000	3 000	3 400
215		40	2.1	2.1	143.5	—	335 000	420 000	3 000	3 400
215		58	2.1	2.1	143.5	—	450 000	620 000	2 600	3 200
260		55	3	3	—	226	450 000	510 000	2 200	2 800
260		55	3	3	154	—	530 000	610 000	2 200	2 800
260		86	3	3	154	—	795 000	1 030 000	2 000	2 600
310		72	5	5	170	260	675 000	770 000	2 000	2 400

Bearing Numbers <sup>(2)</sup>						Abutment and Fillet Dimensions (mm)								Mass (kg) approx		
<sup>(3)</sup> NU NJ NUP N NF						d <sub>a</sub> <sup>(4)</sup> min	d <sub>b</sub> min	d <sub>b</sub> <sup>(5)</sup> max	d <sub>c</sub> min	d <sub>d</sub> min	D <sub>a</sub> <sup>(4)</sup> max	D <sub>b</sub> max	D <sub>b</sub> min		r <sub>a</sub> max	r <sub>b</sub> max
NU1020	NU	NJ	NUP	N	—	108	106.5	111	116	—	142	143.5	139	1.5	1	1.47
N 220	—	—	—	N	NF	111	—	—	—	—	—	169	163	2	2	3.36
NU 220 EM	NU	NJ	NUP	—	—	111	111	116	122	130	169	—	—	2	2	3.81
NU2220 ET	NU	NJ	NUP	—	—	111	111	116	122	130	169	—	—	2	2	4.69
N 320	—	—	—	N	NF	113	—	—	—	—	—	202	190	2.5	2.5	7.59
NU 320	NU	NJ	NUP	—	—	113	113	126	132	143	202	—	—	2.5	2.5	7.69
NU 320 EM	NU	NJ	NUP	—	—	113	113	124	132	143	202	—	—	2.5	2.5	8.63
NU2320 ET	NU	NJ	NUP	—	—	113	113	124	132	143	202	—	—	2.5	2.5	11.8
NU 420	NU	NJ	—	N	NF	116	116	135	141	156	234	234	215	3	3	15.5
NU1021	NU	—	—	N	NF	114	111.5	118	122	—	151	153.5	147	2	1	1.83
N 221	—	—	—	N	NF	116	—	—	—	—	—	179	172	2	2	4.0
NU 221 EM	NU	NJ	NUP	—	—	116	116	121	129	137	179	—	—	2	2	4.58
N 321	—	—	—	N	NF	118	—	—	—	—	—	212	199	2.5	2.5	8.69
NU 321 EM	NU	NJ	NUP	—	—	118	118	131	137	149	212	—	—	2.5	2.5	9.84
NU 421	NU	NJ	—	N	NF	121	121	141	147	162	244	244	225	3	3	17.3
NU1022	NU	NJ	—	N	NF	119	116.5	123	128	—	161	163.5	157	2	1	2.27
N 222	—	—	—	N	NF	121	—	—	—	—	—	189	182	2	2	4.64
NU 222 EM	NU	NJ	NUP	—	—	121	121	129	135	144	189	—	—	2	2	5.37
NU2222 EM	NU	NJ	NUP	—	—	121	121	129	135	144	189	—	—	2	2	7.65
N 322	—	—	—	N	NF	123	—	—	—	—	—	227	211	2.5	2.5	10.3
NU 322 EM	NU	NJ	NUP	—	—	123	123	139	145	158	227	—	—	2.5	2.5	11.8
NU 422	NU	NJ	—	—	—	126	126	151	157	173	264	—	—	3	3	22.1
NU1024	NU	NJ	NUP	N	—	129	126.5	133	138	—	171	173.5	167	2	1	2.43
N 224	—	—	—	N	NF	131	—	—	—	—	—	204	196	2	2	5.63
NU 224 EM	NU	NJ	NUP	—	—	131	131	140	146	156	204	—	—	2	2	6.43
NU2224 EM	NU	NJ	NUP	—	—	131	131	140	146	156	204	—	—	2	2	9.51
N 324	—	—	—	N	NF	133	—	—	—	—	—	247	230	2.5	2.5	12.9
NU 324 EM	NU	NJ	NUP	—	—	133	133	150	156	171	247	—	—	2.5	2.5	15
NU2324 EM	NU	NJ	NUP	—	—	133	133	150	156	171	247	—	—	2.5	2.5	25
NU 424	NU	NJ	NUP	N	—	140	140	166	172	190	290	290	266	4	4	30.2

Notes <sup>(1)</sup> The limiting speeds listed above apply to bearings with machined cages (No suffix). For bearings with pressed cages, reduce the limiting speed by 20%. (Not applicable to bearing numbers with an EM, EW, or ET suffix.)

<sup>(2)</sup> The bearings with suffix ET have polyamide cage. The maximum operating temperature should be less than 120 °C.

Notes <sup>(3)</sup> When L-shaped thrust collars (See section for L-Shaped Thrust Collars starting on page B100) are used, the bearings become the NH type.

<sup>(4)</sup> If axial loads are applied, increase d<sub>a</sub> and reduce D<sub>a</sub> from the values listed above.

<sup>(5)</sup> d<sub>b</sub> (max) are values for adjusting rings for NU, NJ Types.



Bore Diameter 130~160 mm

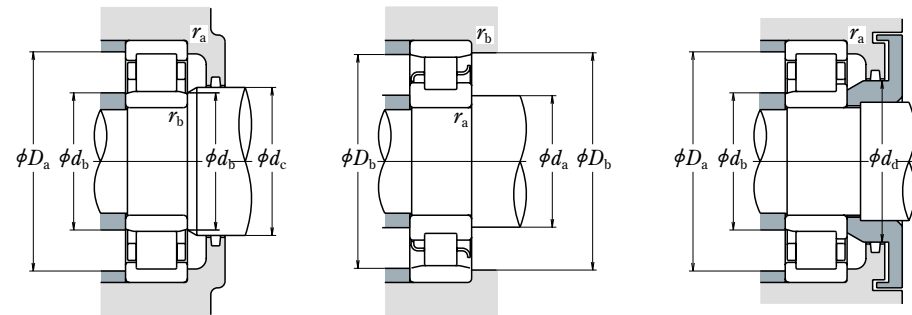
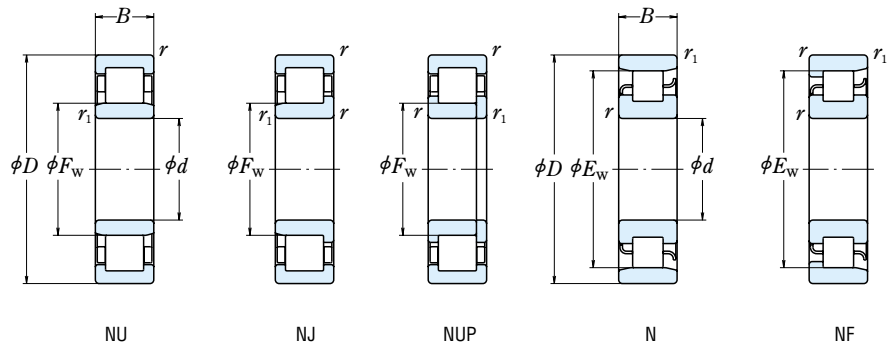

d	Boundary Dimensions (mm)						Basic Load Ratings (N)		Limiting Speeds <sup>(1)</sup> (rpm)	
	D	B	r <sub>min</sub>	r <sub>1min</sub>	F <sub>w</sub>	E <sub>w</sub>	C <sub>r</sub>	C <sub>0r</sub>	Grease	Oil
130	200	33	2	1.1	148	182	172 000	238 000	3 200	3 800
	230	40	3	3	—	204	258 000	320 000	2 600	3 200
	230	40	3	3	153.5	—	365 000	455 000	2 600	3 200
	230	64	3	3	153.5	—	530 000	735 000	2 400	3 000
	280	58	4	4	—	243	500 000	570 000	2 200	2 600
	280	58	4	4	167	—	615 000	735 000	2 200	2 600
	280	93	4	4	167	—	920 000	1 230 000	1 900	2 400
	340	78	5	5	185	285	825 000	955 000	1 800	2 200
140	210	33	2	1.1	158	192	176 000	250 000	3 000	3 600
	250	42	3	3	—	221	297 000	375 000	2 400	3 000
	250	42	3	3	169	—	395 000	515 000	2 400	3 000
	250	68	3	3	169	—	550 000	790 000	2 200	2 800
	300	62	4	4	—	260	550 000	640 000	2 000	2 400
	300	62	4	4	180	—	665 000	795 000	2 000	2 400
	300	102	4	4	180	—	1 020 000	1 380 000	1 700	2 200
	360	82	5	5	198	302	875 000	1 020 000	1 700	2 000
150	225	35	2.1	1.5	169.5	205.5	202 000	294 000	2 800	3 400
	270	45	3	3	—	238	345 000	435 000	2 200	2 800
	270	45	3	3	182	—	450 000	595 000	2 200	2 800
	270	73	3	3	182	—	635 000	930 000	2 000	2 600
	320	65	4	4	—	277	590 000	690 000	1 800	2 200
	320	65	4	4	193	—	760 000	920 000	1 800	2 200
	320	108	4	4	193	—	1 160 000	1 600 000	1 600	2 000
	380	85	5	5	213	—	930 000	1 120 000	1 600	2 000
160	240	38	2.1	1.5	180	220	238 000	340 000	2 600	3 200
	290	48	3	3	—	255	430 000	570 000	2 200	2 600
	290	48	3	3	195	—	500 000	665 000	2 200	2 600
	290	80	3	3	193	—	810 000	1 190 000	1 900	2 400
	340	68	4	4	—	292	700 000	875 000	1 700	2 000
	340	68	4	4	204	—	860 000	1 050 000	1 700	2 000
	340	114	4	4	204	—	1 310 000	1 820 000	1 500	1 900

Bearing Numbers <sup>(2)</sup>						Abutment and Fillet Dimensions (mm)								Mass (kg)		
<sup>(3)</sup>														approx		
NU	NJ	NUP	N	NF		d <sub>a</sub> <sup>(4)</sup> <sub>min</sub>	d <sub>b</sub> <sub>min</sub>	d <sub>b</sub> <sup>(5)</sup> <sub>max</sub>	d <sub>c</sub>	d <sub>d</sub>	D <sub>a</sub> <sup>(4)</sup> <sub>max</sub>	D <sub>b</sub> <sub>max</sub>	D <sub>b</sub> <sub>min</sub>		r <sub>a</sub> <sub>max</sub>	r <sub>b</sub> <sub>max</sub>
NU1026	NU NJ	—	N	NF		139	136.5	146	151	—	191	193.5	184	2	1	3.66
N 226	—	—	N	NF		143	—	—	—	—	—	217	208	2.5	2.5	6.48
NU 226 EM	NU NJ	NUP	—	—		143	143	150	158	168	217	—	—	2.5	2.5	8.03
NU2226 EM	NU NJ	NUP	—	—		143	143	150	158	168	217	—	—	2.5	2.5	9.44
N 326	—	—	N	NF		146	—	—	—	—	—	264	247.5	3	3	17.7
NU326EM	NU NJ	NUP	—	—		146	146	163	169	184	264	—	—	3	3	18.7
NU2326EM	NU NJ	NUP	—	—		146	146	163	169	184	264	—	—	3	3	30
NU 426	NU NJ	—	NF	—		150	150	180	187	208	320	320	291	4	4	39.6
NU1028	NU NJ	NUP	N	—		149	146.5	156	161	—	201	203.5	194	2	1	3.87
N 228	—	—	N	NF		153	—	—	—	—	—	237	225	2.5	2.5	8.08
NU228EM	NU NJ	NUP	—	—		153	153	165	171	182	237	—	—	2.5	2.5	9.38
NU2228EM	NU NJ	NUP	—	—		153	153	165	171	182	237	—	—	2.5	2.5	15.2
N 328	—	—	N	NF		156	—	—	—	—	—	284	266	3	3	21.7
NU328EM	NU NJ	NUP	—	—		156	156	176	182	198	284	—	—	3	3	22.8
NU2328EM	NU NJ	NUP	—	—		156	156	176	182	198	284	—	—	3	3	37.7
NU 428	NU NJ	—	N	—		160	160	193	200	222	340	340	308	4	4	46.4
NU1030	NU NJ	—	N	NF		161	158	167	173	—	214	217	208	2	1.5	4.77
N 230	—	—	N	NF		163	—	—	—	—	—	257	242	2.5	2.5	10.4
NU230EM	NU NJ	NUP	—	—		163	163	177	184	196	257	—	—	2.5	2.5	11.9
NU2230EM	NU NJ	NUP	—	—		163	163	177	184	196	257	—	—	2.5	2.5	19.3
N 330	—	—	N	NF		166	—	—	—	—	—	304	283	3	3	25.8
NU330EM	NU NJ	NUP	—	—		166	166	188	195	213	304	—	—	3	3	27.1
NU2330EM	NU NJ	NUP	—	—		166	166	188	195	213	304	—	—	3	3	45.1
NU 430	NU NJ	—	—	—		170	170	208	216	237	360	—	—	4	4	55.8
NU1032	NU NJ	—	N	NF		171	168	178	184	—	229	232	222	2	1.5	5.81
N 232	—	—	N	NF		173	—	—	—	—	—	277	261	2.5	2.5	14.1
NU232EM	NU NJ	NUP	—	—		173	173	190	197	210	277	—	—	2.5	2.5	14.7
NU2232EM	NU NJ	NUP	—	—		173	173	188	197	210	277	—	—	2.5	2.5	24.5
N 332	—	—	N	—		176	—	—	—	—	—	324	298	3	3	30.8
NU332EM	NU NJ	NUP	—	—		176	176	199	211	228	324	—	—	3	3	32.1
NU2332EM	NU NJ	NUP	—	—		176	176	199	211	228	324	—	—	3	3	53.9

Notes <sup>(1)</sup> The limiting speeds listed above apply to bearings with machined cages (No suffix). For bearings with pressed cages, reduce the limiting speed by 20%. (Not applicable to bearing numbers with an EM, EW, or ET suffix.)

<sup>(2)</sup> The bearings with suffix ET have polyamide cage. The maximum operating temperature should be less than 120 °C.

Notes <sup>(3)</sup> When L-shaped thrust collars (See section for L-Shaped Thrust Collars starting on page B100) are used, the bearings become the NH type.

<sup>(4)</sup> If axial loads are applied, increase d<sub>a</sub> and reduce D<sub>a</sub> from the values listed above.

<sup>(5)</sup> d<sub>b</sub> (max) are values for adjusting rings for NU, NJ Types.

Bore Diameter 170~220 mm

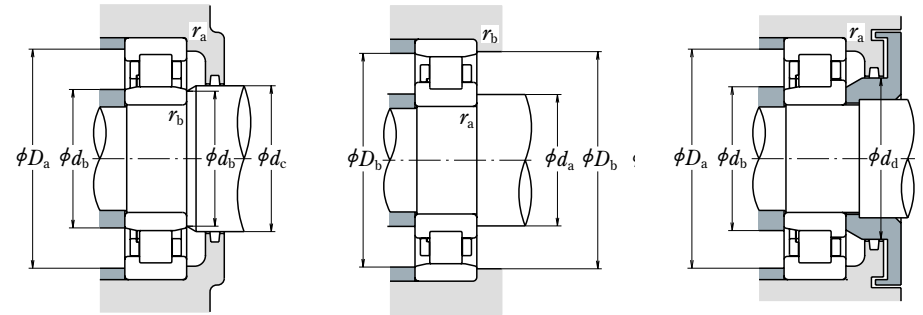
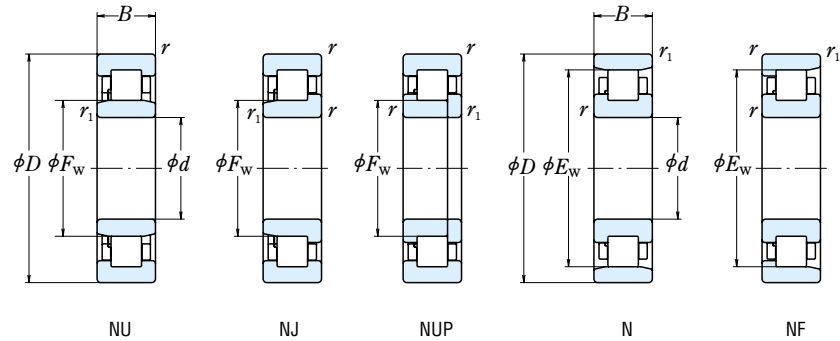

d	Boundary Dimensions (mm)						Basic Load Ratings (N)		Limiting Speeds (rpm)	
	D	B	r <sub>min</sub>	r <sub>1min</sub>	F <sub>w</sub>	E <sub>w</sub>	C <sub>r</sub>	C <sub>0r</sub>	Grease	Oil
170	260	42	2.1	2.1	193	237	287 000	415 000	2 400	2 800
	310	52	4	4	—	272	475 000	635 000	2 000	2 400
	310	52	4	4	207	—	605 000	800 000	2 000	2 400
	310	86	4	4	205	—	925 000	1 330 000	1 800	2 200
	360	72	4	4	—	310	795 000	1 010 000	1 600	2 000
	360	72	4	4	218	—	930 000	1 150 000	1 600	2 000
	360	120	4	4	216	—	1 490 000	2 070 000	1 400	1 800
180	280	46	2.1	2.1	205	255	355 000	510 000	2 200	2 600
	320	52	4	4	—	282	495 000	675 000	1 900	2 200
	320	52	4	4	217	—	625 000	850 000	1 900	2 200
	320	86	4	4	215	—	1 010 000	1 510 000	1 700	2 000
	380	75	4	4	—	328	905 000	1 150 000	1 500	1 800
	380	75	4	4	231	—	985 000	1 230 000	1 500	1 800
	380	126	4	4	227	—	1 560 000	2 220 000	1 300	1 700
190	290	46	2.1	2.1	215	265	365 000	535 000	2 000	2 600
	340	55	4	4	—	299	555 000	770 000	1 800	2 200
	340	55	4	4	230	—	695 000	955 000	1 800	2 200
	340	92	4	4	228	—	1 100 000	1 670 000	1 600	2 000
	400	78	5	5	—	345	975 000	1 260 000	1 400	1 700
	400	78	5	5	245	—	1 060 000	1 340 000	1 400	1 700
	400	132	5	5	240	—	1 770 000	2 520 000	1 300	1 600
200	310	51	2.1	2.1	229	281	390 000	580 000	2 000	2 400
	360	58	4	4	—	316	620 000	865 000	1 700	2 000
	360	58	4	4	243	—	765 000	1 060 000	1 700	2 000
	360	98	4	4	241	—	1 220 000	1 870 000	1 500	1 800
	420	80	5	5	—	360	975 000	1 270 000	1 300	1 600
	420	80	5	5	258	—	1 140 000	1 450 000	1 300	1 600
	420	138	5	5	253	—	1 910 000	2 760 000	1 200	1 500
220	340	56	3	3	250	310	500 000	750 000	1 800	2 200
	400	65	4	4	—	350	760 000	1 080 000	1 500	1 800
	400	65	4	4	270	—	760 000	1 080 000	1 500	1 800
	400	108	4	4	270	—	1 140 000	1 810 000	1 300	1 600
	460	88	5	5	—	396	1 190 000	1 570 000	1 200	1 500
	460	88	5	5	284	—	1 190 000	1 570 000	1 200	1 500

Bearing Numbers	Abutment and Fillet Dimensions (mm)										Mass (kg) approx					
	NU	NJ	NUP	N	NF	d <sub>a</sub> (2) min	d <sub>b</sub> min	d <sub>b</sub> (3) max	d <sub>c</sub> min	d <sub>d</sub> min		D <sub>a</sub> (2) max	D <sub>b</sub> max	D <sub>b</sub> min	r <sub>a</sub> max	r <sub>b</sub> max
<b>NU1034</b>	<b>NU</b>	<b>NJ</b>	—	<b>N</b>	—	181	181	190	197	—	249	249	239	2	2	7.91
<b>N 234</b>	—	—	—	<b>N</b>	<b>NF</b>	186	—	—	—	—	294	278	3	3	17.4	
<b>NU234EM</b>	<b>NU</b>	<b>NJ</b>	<b>NUP</b>	—	—	186	186	202	211	223	294	—	—	3	3	18.3
<b>NU2234EM</b>	<b>NU</b>	<b>NJ</b>	<b>NUP</b>	—	—	186	186	200	211	223	294	—	—	3	3	29.9
<b>N 334</b>	—	—	—	<b>N</b>	—	186	—	—	—	—	344	316	3	3	36.6	
<b>NU334EM</b>	<b>NU</b>	<b>NJ</b>	<b>NUP</b>	—	—	186	186	213	223	241	344	—	—	3	3	37.9
<b>NU2334EM</b>	<b>NU</b>	<b>NJ</b>	<b>NUP</b>	—	—	186	186	210	223	241	344	—	—	3	3	63.4
<b>NU1036</b>	<b>NU</b>	<b>NJ</b>	—	<b>N</b>	<b>NF</b>	191	191	202	209	—	269	269	258	2	2	10.2
<b>N 236</b>	—	—	—	<b>N</b>	<b>NF</b>	196	—	—	—	—	304	288	3	3	18.1	
<b>NU236EM</b>	<b>NU</b>	<b>NJ</b>	<b>NUP</b>	—	—	196	196	212	221	233	304	—	—	3	3	19
<b>NU2236EM</b>	<b>NU</b>	<b>NJ</b>	<b>NUP</b>	—	—	196	196	210	221	233	304	—	—	3	3	31.4
<b>N 336</b>	—	—	—	<b>N</b>	<b>NF</b>	196	—	—	—	—	364	335	3	3	42.6	
<b>NU336EM</b>	<b>NU</b>	<b>NJ</b>	<b>NUP</b>	—	—	196	196	226	235	255	364	—	—	3	3	44
<b>NU2336EM</b>	<b>NU</b>	<b>NJ</b>	<b>NUP</b>	—	—	196	196	222	235	255	364	—	—	3	3	74.6
<b>NU1038</b>	<b>NU</b>	<b>NJ</b>	—	<b>N</b>	—	201	201	212	219	—	279	279	268	2	2	10.7
<b>N 238</b>	—	—	—	<b>N</b>	<b>NF</b>	206	—	—	—	—	324	305	3	3	22	
<b>NU238EM</b>	<b>NU</b>	<b>NJ</b>	<b>NUP</b>	—	—	206	206	225	234	247	324	—	—	3	3	23
<b>NU2238EM</b>	<b>NU</b>	<b>NJ</b>	<b>NUP</b>	—	—	206	206	223	234	247	324	—	—	3	3	38.3
<b>N 338</b>	—	—	—	<b>N</b>	—	210	—	—	—	—	380	352	4	4	48.7	
<b>NU338EM</b>	<b>NU</b>	<b>NJ</b>	<b>NUP</b>	—	—	210	210	240	248	268	380	—	—	4	4	50.6
<b>NU2338EM</b>	<b>NU</b>	<b>NJ</b>	<b>NUP</b>	—	—	210	210	235	248	268	380	—	—	4	4	86.2
<b>NU1040</b>	<b>NU</b>	<b>NJ</b>	—	<b>N</b>	<b>NF</b>	211	211	226	233	—	299	299	284	2	2	14
<b>N 240</b>	—	—	—	<b>N</b>	<b>NF</b>	216	—	—	—	—	344	323	3	3	26.2	
<b>NU240EM</b>	<b>NU</b>	<b>NJ</b>	<b>NUP</b>	—	—	216	216	238	247	261	344	—	—	3	3	27.4
<b>NU2240EM</b>	<b>NU</b>	<b>NJ</b>	<b>NUP</b>	—	—	216	216	235	247	261	344	—	—	3	3	46.1
<b>N 340</b>	—	—	—	<b>N</b>	<b>NF</b>	220	—	—	—	—	400	367	4	4	55.3	
<b>NU340EM</b>	<b>NU</b>	<b>NJ</b>	<b>NUP</b>	—	—	220	220	252	263	283	400	—	—	4	4	57.1
<b>NU2340EM</b>	<b>NU</b>	<b>NJ</b>	<b>NUP</b>	—	—	220	220	247	263	283	400	—	—	4	4	99.3
<b>NU1044</b>	<b>NU</b>	<b>NJ</b>	—	<b>N</b>	—	233	233	247	254	—	327	327	313	2.5	2.5	18.2
<b>N 244</b>	—	—	—	<b>N</b>	<b>NF</b>	236	—	—	—	—	384	357	3	3	37	
<b>NU244EM</b>	<b>NU</b>	<b>NJ</b>	<b>NUP</b>	—	—	236	236	264	273	289	384	—	—	3	3	37.3
<b>NU2244EM</b>	<b>NU</b>	—	—	—	—	—	236	264	273	289	384	—	—	3	3	61.8
<b>N 344</b>	—	—	—	<b>N</b>	—	240	—	—	—	—	440	403	4	4	72.8	
<b>NU344EM</b>	<b>NU</b>	<b>NJ</b>	—	—	—	240	240	278	287	307	440	—	—	4	4	74.6

Notes (1) When L-shaped thrust collars (Refer to page B101) are used, the bearings become the NH Type.

(2) If axial loads are applied, increase d<sub>a</sub> and reduce D<sub>a</sub> from the values listed above.

(3) d<sub>b</sub> (max) are values for adjusting rings for NU, NJ Types.

Bore Diameter 240~500 mm

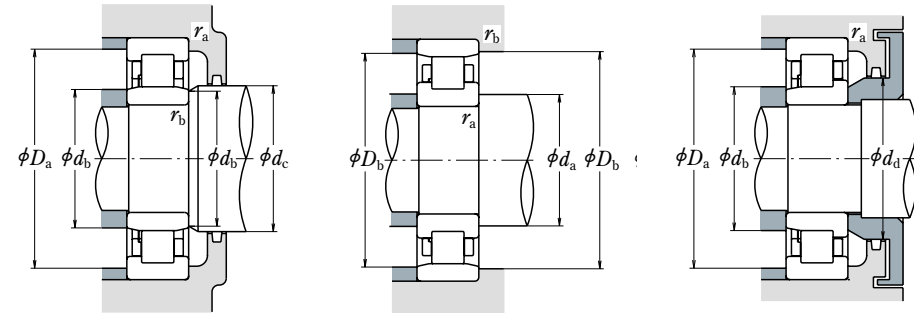
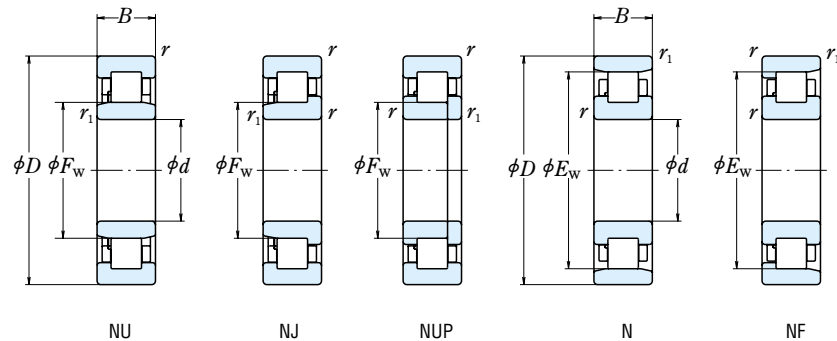

d	Boundary Dimensions (mm)						Basic Load Ratings (N)		Limiting Speeds (rpm)	
	D	B	r <sub>min</sub>	r <sub>1min</sub>	F <sub>w</sub>	E <sub>w</sub>	C <sub>r</sub>	C <sub>0r</sub>	Grease	Oil
<b>240</b>	360	56	3	3	270	330	530 000	820 000	1 600	2 000
	440	72	4	4	—	385	935 000	1 340 000	1 300	1 600
	440	72	4	4	295	—	935 000	1 340 000	1 300	1 600
	440	120	4	4	295	—	1 440 000	2 320 000	1 200	1 500
	500	95	5	5	—	430	1 360 000	1 820 000	1 100	1 300
<b>260</b>	400	65	4	4	296	364	645 000	1 000 000	1 500	1 800
	480	80	5	5	—	420	1 100 000	1 580 000	1 200	1 500
	480	80	5	5	320	—	1 100 000	1 580 000	1 200	1 500
	480	130	5	5	320	—	1 710 000	2 770 000	1 100	1 300
	540	102	6	6	336	—	1 540 000	2 090 000	1 000	1 200
<b>280</b>	420	65	4	4	316	384	660 000	1 050 000	1 400	1 700
	500	80	5	5	—	440	1 140 000	1 680 000	1 100	1 400
	500	80	5	5	340	—	1 140 000	1 680 000	1 100	1 400
<b>300</b>	460	74	4	4	340	420	885 000	1 400 000	1 300	1 500
	540	85	5	5	364	—	1 400 000	2 070 000	1 100	1 300
<b>320</b>	480	74	4	4	360	440	905 000	1 470 000	1 200	1 400
	580	92	5	5	—	510	1 540 000	2 270 000	950	1 200
	580	92	5	5	390	—	1 540 000	2 270 000	950	1 200
<b>340</b>	520	82	5	5	385	475	1 080 000	1 740 000	1 100	1 300
<b>360</b>	540	82	5	5	405	495	1 110 000	1 830 000	1 000	1 300
<b>380</b>	560	82	5	5	425	—	1 140 000	1 910 000	1 000	1 200
<b>400</b>	600	90	5	5	450	550	1 360 000	2 280 000	900	1 100
<b>420</b>	620	90	5	5	470	570	1 390 000	2 380 000	850	1 100
<b>440</b>	650	94	6	6	493	—	1 470 000	2 530 000	800	1 000
<b>460</b>	680	100	6	6	516	624	1 580 000	2 740 000	750	950
<b>480</b>	700	100	6	6	536	644	1 620 000	2 860 000	750	900
<b>500</b>	720	100	6	6	556	664	1 660 000	2 970 000	710	850

Bearing Numbers	Abutment and Fillet Dimensions (mm)										Mass (kg) approx					
	NU	NJ	NUP	N	NF	d <sub>a</sub> <sup>(2)</sup> <sub>min</sub>	d <sub>b</sub> <sub>min</sub>	d <sub>b</sub> <sup>(3)</sup> <sub>max</sub>	d <sub>c</sub>	d <sub>d</sub> <sub>min</sub>		D <sub>a</sub> <sup>(2)</sup> <sub>max</sub>	D <sub>b</sub> <sub>max</sub>	D <sub>b</sub> <sub>min</sub>	r <sub>a</sub> <sub>max</sub>	r <sub>b</sub> <sub>max</sub>
<b>NU1048</b>	NU	NJ	—	N	—	253	253	266	275	—	347	347	333	2.5	2.5	19.5
<b>N 248</b>	—	—	—	N	NF	256	—	—	—	—	—	424	392	3	3	49.6
<b>NU 248</b>	NU	NJ	NUP	—	—	256	256	289	298	316	424	—	—	3	3	50.4
<b>NU2248</b>	NU	—	—	—	—	—	256	289	298	316	424	—	—	3	3	84.9
<b>N 348</b>	—	—	—	N	—	260	—	—	—	—	—	480	438	4	4	92.3
<b>NU 348</b>	NU	NJ	—	—	—	260	260	304	313	333	480	—	—	4	4	94.6
<b>NU1052</b>	NU	NJ	—	N	NF	276	276	292	300	—	384	384	367	3	3	29.1
<b>N 252</b>	—	—	—	N	—	280	—	—	—	—	—	460	428	4	4	66.2
<b>NU 252</b>	NU	NJ	—	—	—	280	280	314	323	343	460	—	—	4	4	67.1
<b>NU2252</b>	NU	—	NUP	—	—	280	280	314	323	343	460	—	—	4	4	111
<b>NU 352</b>	NU	NJ	—	—	—	286	286	330	339	359	514	—	—	5	5	118
<b>NU1056</b>	NU	NJ	NUP	N	NF	296	296	312	320	—	404	404	387	3	3	30.8
<b>N 256</b>	—	—	—	N	NF	300	—	—	—	—	—	480	448	4	4	69.6
<b>NU 256</b>	NU	NJ	—	—	—	300	300	334	344	364	480	—	—	4	4	70.7
<b>NU1060</b>	NU	NJ	—	N	NF	316	316	336	344	—	444	444	424	3	3	43.7
<b>NU 260</b>	NU	NJ	—	—	—	320	320	358	368	391	520	—	—	4	4	89.2
<b>NU1064</b>	NU	—	—	N	NF	336	336	356	365	—	464	464	444	3	3	46.1
<b>N 264</b>	—	—	—	N	—	340	—	—	—	—	—	560	519	4	4	110
<b>NU 264</b>	NU	NJ	—	—	—	340	340	384	394	420	560	—	—	4	4	112
<b>NU1068</b>	NU	NJ	—	N	NF	360	360	381	390	—	500	500	479	4	4	61.8
<b>NU1072</b>	NU	—	—	N	NF	380	380	400	410	—	520	520	499	4	4	64.6
<b>NU1076</b>	NU	—	—	—	—	—	400	420	430	—	540	—	—	4	4	67.5
<b>NU1080</b>	NU	—	NUP	N	—	420	420	445	455	—	580	580	554.5	4	4	88.2
<b>NU1084</b>	NU	—	—	N	—	440	440	465	475	—	600	600	574.5	4	4	91.7
<b>NU1088</b>	NU	—	—	—	—	—	466	488	498	—	624	—	—	5	5	105
<b>NU1092</b>	NU	—	NUP	N	—	486	486	511	521	—	654	654	628.5	5	5	123
<b>NU1096</b>	NU	NJ	—	N	—	506	506	531	541	—	674	674	654	5	5	127
<b>NU10/500</b>	NU	—	—	N	—	526	526	551	558	—	694	694	674	5	5	131

Notes (1) When L-shaped thrust collars (Refer to page B101) are used, the bearings become the NH Type.  
 (2) If axial loads are applied, increase d<sub>a</sub> and reduce D<sub>a</sub> from the values listed above.  
 (3) d<sub>b</sub> (max) are values for adjusting rings for NU, NJ Types.

L-Shaped Thrust Collars

Bore Diameter 20~85 mm

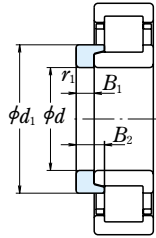

L-Shaped Thrust Collar

Bore Diameter 90~320 mm

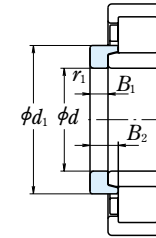

L-Shaped Thrust Collar

d	Boundary Dimensions (mm)				Bearing Numbers	Mass (kg) approx
	d <sub>1</sub>	B <sub>1</sub>	B <sub>2</sub>	r <sub>1 min</sub>		
20	30	3	6.75	0.6	HJ 204	0.012
	29.8	3	5.5	0.6	HJ 204 E	0.011
	30	3	7.5	0.6	HJ 2204	0.012
	29.8	3	6.5	0.6	HJ 2204 E	0.012
	31.8	4	7.5	0.6	HJ 304	0.017
	31.4	4	6.5	0.6	HJ 304 E	0.017
25	31.8	4	8.5	0.6	HJ 2304	0.017
	31.4	4	7.5	0.6	HJ 2304 E	0.018
	34.8	3	6	0.6	HJ 205 E	0.014
	34.8	3	6.5	0.6	HJ 2205 E	0.014
	38.2	4	7	1.1	HJ 305 E	0.025
	38.2	4	8	1.1	HJ 2305 E	0.026
30	43.6	6	10.5	1.5	HJ 405	0.057
	41.4	4	7	0.6	HJ 206 E	0.025
	41.4	4	7.5	0.6	HJ 2206 E	0.025
	45.1	5	8.5	1.1	HJ 306 E	0.042
	45.1	5	9.5	1.1	HJ 2306 E	0.043
	50.5	7	11.5	1.5	HJ 406	0.080
35	48.2	4	7	0.6	HJ 207 E	0.033
	48.2	4	8.5	0.6	HJ 2207 E	0.035
	51.1	6	9.5	1.1	HJ 307 E	0.060
	51.1	6	11	1.1	HJ 2307 E	0.062
	59	8	13	1.5	HJ 407	0.12
	40	54.1	5	8.5	1.1	HJ 208 E
54.1		5	9	1.1	HJ 2208 E	0.050
57.7		7	11	1.5	HJ 308 E	0.088
57.7		7	12.5	1.5	HJ 2308 E	0.091
64.8		8	13	2	HJ 408	0.14
45		59.1	5	8.5	1.1	HJ 209 E
	59.1	5	9	1.1	HJ 2209 E	0.055
	64.5	7	11.5	1.5	HJ 309 E	0.11
	64.5	7	13	1.5	HJ 2309 E	0.113
	71.8	8	13.5	2	HJ 409	0.175
	50	64.1	5	9	1.1	HJ 210 E
64.1		5	9	1.1	HJ 2210 E	0.061
71.4		8	13	2	HJ 310 E	0.151
71.4		8	14.5	2	HJ 2310 E	0.155
78.8		9	14.5	2.1	HJ 410	0.23

d	Boundary Dimensions (mm)				Bearing Numbers	Mass (kg) approx
	d <sub>1</sub>	B <sub>1</sub>	B <sub>2</sub>	r <sub>1 min</sub>		
55	70.9	6	9.5	1.1	HJ 211 E	0.087
	70.9	6	10	1.1	HJ 2211 E	0.088
	77.6	9	14	2	HJ 311 E	0.195
	77.6	9	15.5	2	HJ 2311 E	0.20
	85.2	10	16.5	2.1	HJ 411	0.29
	60	77.7	6	10	1.5	HJ 212 E
77.7		6	10	1.5	HJ 2212 E	0.108
84.5		9	14.5	2.1	HJ 312 E	0.231
84.5		9	16	2.1	HJ 2312 E	0.237
91.8		10	16.5	2.1	HJ 412	0.34
65		84.5	6	10	1.5	HJ 213 E
	84.5	6	10.5	1.5	HJ 2213 E	0.131
	90.6	10	15.5	2.1	HJ 313 E	0.288
	90.6	10	18	2.1	HJ 2313 E	0.298
	98.5	11	18	2.1	HJ 413	0.42
	70	89.5	7	11	1.5	HJ 214 E
89.5		7	11.5	1.5	HJ 2214 E	0.158
97.5		10	15.5	2.1	HJ 314 E	0.33
97.5		10	18.5	2.1	HJ 2314 E	0.345
110.5		12	20	3	HJ 414	0.605
75		94.5	7	11	1.5	HJ 215 E
	94.5	7	11.5	1.5	HJ 2215 E	0.167
	104.2	11	16.5	2.1	HJ 315 E	0.41
	104.2	11	19.5	2.1	HJ 2315 E	0.43
	116	13	21.5	3	HJ 415	0.71
	80	101.6	8	12.5	2	HJ 216 E
101.6		8	12.5	2	HJ 2216 E	0.222
110.6		11	17	2.1	HJ 316 E	0.46
110.6		11	20	2.1	HJ 2316 E	0.48
122		13	22	3	HJ 416	0.78
85		107.6	8	12.5	2	HJ 217 E
	107.6	8	13	2	HJ 2217 E	0.252
	117.9	12	18.5	3	HJ 317 E	0.575
	117.9	12	22	3	HJ 2317 E	0.595
	126	14	24	4	HJ 417	0.88

d	Boundary Dimensions (mm)				Bearing Numbers	Mass (kg) approx	
	d <sub>1</sub>	B <sub>1</sub>	B <sub>2</sub>	r <sub>1 min</sub>			
90	114.4	9	14	2	HJ 218 E	0.32	
	114.4	9	15	2	HJ 2218 E	0.325	
	124.2	12	18.5	3	HJ 318 E	0.63	
	124.2	12	22	3	HJ 2318 E	0.66	
	137	14	24	4	HJ 418	1.05	
	95	120.6	9	14	2.1	HJ 219 E	0.355
120.6		9	15.5	2.1	HJ 2219 E	0.365	
132.2		13	20.5	3	HJ 319 E	0.785	
132.2		13	24.5	3	HJ 2319 E	0.815	
147		15	25.5	4	HJ 419	1.3	
100		127.5	10	15	2.1	HJ 220 E	0.44
	127.5	10	16	2.1	HJ 2220 E	0.45	
	139.6	13	20.5	3	HJ 320 E	0.89	
	139.6	13	23.5	3	HJ 2320 E	0.92	
	153.5	16	27	4	HJ 420	1.5	
	105	147	13	20.5	3	HJ 321 E	0.97
159.5		16	27	4	HJ 421	1.65	
110		141.7	11	17	2.1	HJ 222 E	0.62
		141.7	11	19.5	2.1	HJ 2222 E	0.645
		155.8	14	22	3	HJ 322 E	1.21
		155.8	14	26.5	3	HJ 2322 E	1.27
	171	17	29.5	4	HJ 422	2.1	
	120	153.4	11	17	2.1	HJ 224 E	0.71
153.4		11	20	2.1	HJ 2224 E	0.745	
168.6		14	22.5	3	HJ 324 E	1.41	
168.6		14	26	3	HJ 2324 E	1.46	
188		17	30.5	5	HJ 424	2.6	
130		164.2	11	17	3	HJ 226 E	0.79
	164.2	11	21	3	HJ 2226 E	0.84	
	182.3	14	23	4	HJ 326 E	1.65	
	182.3	14	28	4	HJ 2326 E	1.73	
	205	18	32	5	HJ 426	3.3	
	140	180	11	18	3	HJ 228 E	0.99
180		11	23	3	HJ 2228 E	1.07	
196		15	25	4	HJ 328 E	2.04	
196		15	31	4	HJ 2328 E	2.14	
219		18	33	5	HJ 428	3.75	

d	Boundary Dimensions (mm)				Bearing Numbers	Mass (kg) approx		
	d <sub>1</sub>	B <sub>1</sub>	B <sub>2</sub>	r <sub>1 min</sub>				
150	193.7	12	19.5	3	HJ 230 E	1.26		
	193.7	12	24.5	3	HJ 2230 E	1.35		
	210	15	25	4	HJ 330 E	2.35		
	210	15	31.5	4	HJ 2330 E	2.48		
	234	20	36.5	5	HJ 430	4.7		
	160	207.3	12	20	3	HJ 232 E	1.48	
206.1		12	24.5	3	HJ 2232 E	1.55		
222.1		15	25	4	HJ 332 E	2.59		
222.1		15	32	4	HJ 2332 E	2.76		
170		220.8	12	20	4	HJ 234 E	1.7	
		219.5	12	24	4	HJ 2234 E	1.79	
	238	16	33.5	4	HJ 334 E	3.25		
	180	230.8	12	20	4	HJ 236 E	1.79	
		229.5	12	24	4	HJ 2236 E	1.88	
		252	17	35	4	HJ 336 E	3.85	
190		244.5	13	21.5	4	HJ 238 E	2.19	
		243.2	13	26.5	4	HJ 2238 E	2.31	
		266	18	36.5	5	HJ 338 E	4.45	
	200	258.2	14	23	4	HJ 240 E	2.65	
		258	14	34	4	HJ 2240 E	2.6	
		256.9	14	28	4	HJ 2240 E	2.78	
280		18	30	5	HJ 340 E	5.0		
220		286	15	27.5	4	HJ 244	3.55	
		286	15	36.5	4	HJ 2244	3.55	
	307	20	36	5	HJ 344	7.05		
	240	313	16	29.5	4	HJ 248	4.65	
		313	16	38.5	4	HJ 2248	4.65	
		335	22	39.5	5	HJ 348	8.2	
260		340	18	33	5	HJ 252	6.2	
		340	18	40.5	5	HJ 2252	6.2	
		362	24	43	6	HJ 352	11.4	
	280	360	18	33	5	HJ 256	7.4	
		300	387	20	34.5	5	HJ 260	9.15
			320	415	21	37	5	HJ 264

Bore Diameter 25~140 mm

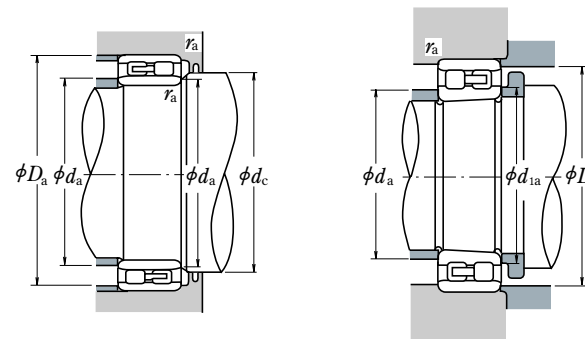
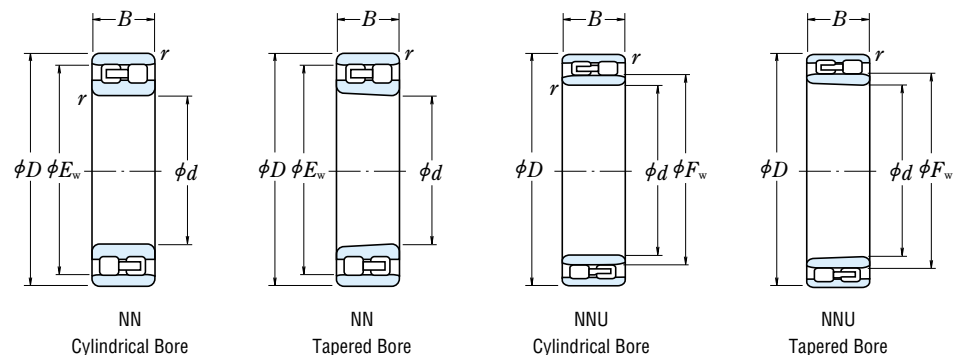

d	Boundary Dimensions (mm)					Basic Load Ratings (N)		Limiting Speeds (rpm)	
	D	B	r <sub>min</sub>	F <sub>w</sub>	E <sub>w</sub>	C <sub>r</sub>	C <sub>0r</sub>	Grease	Oil
25	47	16	0.6	—	41.3	25 800	30 000	14 000	17 000
30	55	19	1	—	48.5	31 000	37 000	12 000	14 000
35	62	20	1	—	55	39 500	50 000	10 000	12 000
40	68	21	1	—	61	43 500	55 500	9 000	11 000
45	75	23	1	—	67.5	52 000	68 500	8 500	10 000
50	80	23	1	—	72.5	53 000	72 500	7 500	9 000
55	90	26	1.1	—	81	69 500	96 500	6 700	8 000
60	95	26	1.1	—	86.1	73 500	106 000	6 300	7 500
65	100	26	1.1	—	91	77 000	116 000	6 000	7 100
70	110	30	1.1	—	100	97 500	148 000	5 600	6 700
75	115	30	1.1	—	105	96 500	149 000	5 300	6 300
80	125	34	1.1	—	113	119 000	186 000	4 800	6 000
85	130	34	1.1	—	118	125 000	201 000	4 500	5 600
90	140	37	1.5	—	127	143 000	228 000	4 300	5 000
95	145	37	1.5	—	132	150 000	246 000	4 000	5 000
100	140 150	40 37	1.1 1.5	112 —	— 137	155 000 157 000	295 000 265 000	4 000 4 000	5 000 4 800
105	145 160	40 41	1.1 2	117 —	— 146	161 000 198 000	315 000 320 000	3 800 3 800	4 800 4 500
110	150 170	40 45	1.1 2	122 —	— 155	167 000 229 000	335 000 375 000	3 600 3 400	4 500 4 300
120	165 180	45 46	1.1 2	133.5 —	— 165	183 000 239 000	360 000 405 000	3 200 3 200	4 000 3 800
130	180 200	50 52	1.5 2	144 —	— 182	274 000 284 000	545 000 475 000	3 000 3 000	3 800 3 600
140	190 210	50 53	1.5 2	154 —	— 192	283 000 298 000	585 000 515 000	2 800 2 800	3 600 3 400

Bearing Numbers		Abutment and Fillet Dimensions (mm)							Mass (kg)
Cylindrical Bore	Tapered Bore <sup>(1)</sup>	d <sub>a</sub> <sup>(2)</sup>		d <sub>1a</sub> min	d <sub>c</sub> min	D <sub>a</sub> max	r <sub>a</sub> max	approx	
		min	max						
NN 3005	NN 3005 K	29	—	29	—	43	42	0.6	
NN 3006	NN 3006 K	35	—	36	—	50	50	0.198	
NN 3007	NN 3007 K	40	—	41	—	57	56	0.258	
NN 3008	NN 3008 K	45	—	46	—	63	62	0.309	
NN 3009	NN 3009 K	50	—	51	—	70	69	0.407	
NN 3010	NN 3010 K	55	—	56	—	75	74	0.436	
NN 3011	NN 3011 K	61.5	—	62	—	83.5	83	0.647	
NN 3012	NN 3012 K	66.5	—	67	—	88.5	88	0.693	
NN 3013	NN 3013 K	71.5	—	72	—	93.5	93	0.741	
NN 3014	NN 3014 K	76.5	—	77	—	103.5	102	1.06	
NN 3015	NN 3015 K	81.5	—	82	—	108.5	107	1.11	
NN 3016	NN 3016 K	86.5	—	87	—	118.5	115	1.54	
NN 3017	NN 3017 K	91.5	—	92	—	123.5	120	1.63	
NN 3018	NN 3018 K	98	—	99	—	132	129	2.09	
NN 3019	NN 3019 K	103	—	104	—	137	134	2.19	
NNU 4920	NNU 4920 K	106.5	111	108	115	133.5	—	1.9	
NN 3020	NN 3020 K	108	—	109	—	142	139	2.28	
NNU 4921	NNU 4921 K	111.5	116	113	120	138.5	—	1.99	
NN 3021	NN 3021 K	114	—	115	—	151	148	2.88	
NNU 4922	NNU 4922 K	116.5	121	118	125	143.5	—	2.07	
NN 3022	NN 3022 K	119	—	121	—	161	157	3.71	
NNU 4924	NNU 4924 K	126.5	133	128	137	158.5	—	2.85	
NN 3024	NN 3024 K	129	—	131	—	171	167	4.04	
NNU 4926	NNU 4926 K	138	143	140	148	172	—	3.85	
NN 3026	NN 3026 K	139	—	141	—	191	185	5.88	
NNU 4928	NNU 4928 K	148	153	150	158	182	—	4.08	
NN 3028	NN 3028 K	149	—	151	—	201	195	6.34	

Note <sup>(1)</sup> The suffix K represents bearings with tapered bores (taper 1 : 12).

Remarks Production of double-row cylindrical roller bearings is generally in the high precision classes (Class 5 or better).

Note <sup>(2)</sup> d<sub>a</sub> (max) are values for adjusting rings for the NNU Type.

Bore Diameter 150~360 mm

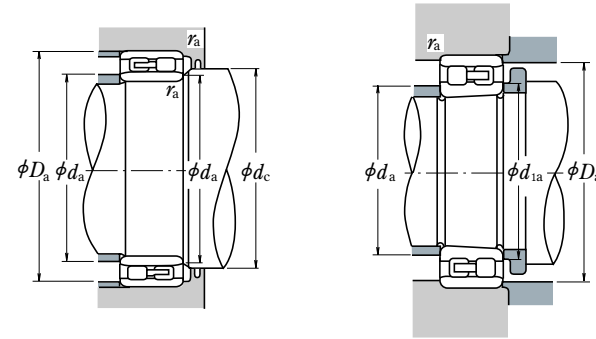
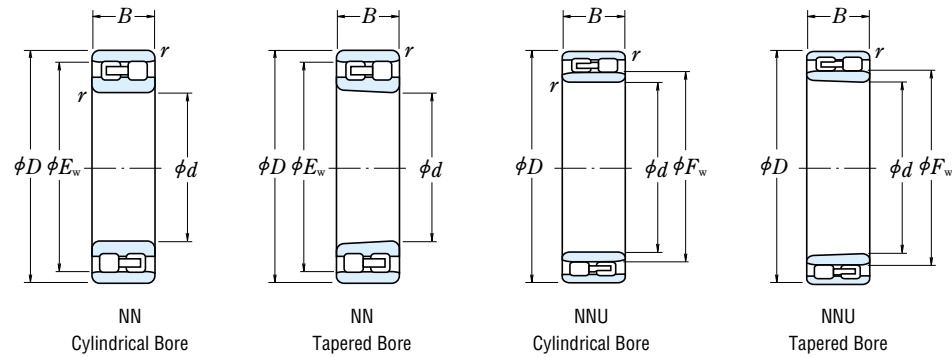

d	Boundary Dimensions (mm)					Basic Load Ratings (N)		Limiting Speeds (rpm)	
	D	B	r <sub>min</sub>	F <sub>w</sub>	E <sub>w</sub>	C <sub>r</sub>	C <sub>0r</sub>	Grease	Oil
150	210	60	2	167	—	350 000	715 000	2 600	3 200
	225	56	2.1	—	206	335 000	585 000	2 600	3 000
160	220	60	2	177	—	365 000	760 000	2 400	3 000
	240	60	2.1	—	219	375 000	660 000	2 400	2 800
170	230	60	2	187	—	375 000	805 000	2 400	2 800
	260	67	2.1	—	236	450 000	805 000	2 200	2 600
180	250	69	2	200	—	480 000	1 020 000	2 200	2 600
	280	74	2.1	—	255	565 000	995 000	2 000	2 400
190	260	69	2	211.5	—	485 000	1 060 000	2 000	2 600
	290	75	2.1	—	265	595 000	1 080 000	2 000	2 400
200	280	80	2.1	223	—	570 000	1 220 000	1 900	2 400
	310	82	2.1	—	282	655 000	1 170 000	1 800	2 200
220	300	80	2.1	243	—	600 000	1 330 000	1 700	2 200
	340	90	3	—	310	815 000	1 480 000	1 700	2 000
240	320	80	2.1	263	—	625 000	1 450 000	1 600	2 000
	360	92	3	—	330	855 000	1 600 000	1 500	1 800
260	360	100	2.1	289	—	935 000	2 100 000	1 400	1 800
	400	104	4	—	364	1 030 000	1 920 000	1 400	1 700
280	380	100	2.1	309	—	960 000	2 230 000	1 300	1 700
	420	106	4	—	384	1 080 000	2 080 000	1 300	1 500
300	420	118	3	336	—	1 230 000	2 870 000	1 200	1 500
	460	118	4	—	418	1 290 000	2 460 000	1 200	1 400
320	440	118	3	356	—	1 260 000	3 050 000	1 100	1 400
	480	121	4	—	438	1 350 000	2 670 000	1 100	1 300
340	520	133	5	—	473	1 670 000	3 300 000	1 000	1 200
360	540	134	5	—	493	1 700 000	3 450 000	950	1 200

Note (1) The suffix K represents bearings with tapered bores (taper 1 : 12).

Remarks Production of double-row cylindrical roller bearings is generally in the high precision classes (Class 5 or better).

Bearing Numbers		Abutment and Fillet Dimensions (mm)							Mass (kg)
Cylindrical Bore	Tapered Bore <sup>(1)</sup>	d <sub>a</sub> <sup>(2)</sup>	d <sub>1a</sub>	d <sub>c</sub>	D <sub>a</sub>	r <sub>a</sub>		approx	
		min	max	min	max	min	max		
NNU 4930 NN 3030	NNU 4930 K NN 3030 K	159	166	162	171	201	—	2	6.39
		161	—	162	—	214	209	2	7.77
NNU 4932 NN 3032	NNU 4932 K NN 3032 K	169	176	172	182	211	—	2	6.76
		171	—	172	—	229	222	2	9.41
NNU 4934 NN 3034	NNU 4934 K NN 3034 K	179	186	182	192	221	—	2	7.12
		181	—	183	—	249	239	2	12.8
NNU 4936 NN 3036	NNU 4936 K NN 3036 K	189	199	193	205	241	—	2	10.4
		191	—	193	—	269	258	2	16.8
NNU 4938 NN 3038	NNU 4938 K NN 3038 K	199	211	203	217	251	—	2	10.9
		201	—	203	—	279	268	2	17.8
NNU 4940 NN 3040	NNU 4940 K NN 3040 K	211	222	214	228	269	—	2	15.3
		211	—	214	—	299	285	2	22.7
NNU 4944 NN 3044	NNU 4944 K NN 3044 K	231	242	234	248	289	—	2	16.6
		233	—	236	—	327	313	2.5	29.6
NNU 4948 NN 3048	NNU 4948 K NN 3048 K	251	262	254	269	309	—	2	18
		253	—	256	—	347	334	2.5	32.7
NNU 4952 NN 3052	NNU 4952 K NN 3052 K	271	288	275	295	349	—	2	31.1
		276	—	278	—	384	368	3	47.7
NNU 4956 NN 3056	NNU 4956 K NN 3056 K	291	308	295	315	369	—	2	33
		296	—	298	—	404	388	3	51.1
NNU 4960 NN 3060	NNU 4960 K NN 3060 K	313	335	318	343	407	—	2.5	51.9
		316	—	319	—	444	422	3	70.7
NNU 4964 NN 3064	NNU 4964 K NN 3064 K	333	355	338	363	427	—	2.5	54.9
		336	—	340	—	464	442	3	76.6
NNU 3068	NN 3068 K	360	—	365	—	500	477	4	102
NN 3072	NN 3072 K	380	—	385	—	520	497	4	106

Note (2) d<sub>a</sub> (max) are values for adjusting rings for the NNU Type.



# TAPERED ROLLER BEARINGS

## METRIC DESIGN TAPERED ROLLER BEARINGS

Bore Diameter 15~100mm .....Pages B116~B123  
 Bore Diameter 105~240mm .....Pages B124~B129  
 Bore Diameter 260~440mm .....Pages B130~B131

## INCH DESIGN TAPERED ROLLER BEARINGS

Bore Diameter 12.000~ 47.625mm .....Pages B132~B145  
 Bore Diameter 48.412~ 69.850mm .....Pages B146~B153  
 Bore Diameter 70.000~206.375mm .....Pages B154~B167

The index for inch design tapered roller bearings is in Appendix 14 (Page C26).

## DOUBLE-ROW TAPERED ROLLER BEARINGS

Bore Diameter 40~260mm .....Pages B168~B177

**Four-Row Tapered Roller Bearings** are described on pages B294 to B299.



## DESIGN, TYPES, AND FEATURES

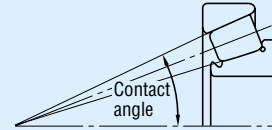

Tapered roller bearings are designed so the apices of the cones formed by the raceways of the cone and cup and the conical rollers all coincide at one point on the axis of the bearing. When a radial load is imposed, an axial force component occurs; therefore, it is necessary to use two bearings in opposition or some other multiple arrangement.

For metric-design medium-angle and steep-angle tapered roller bearings, the respective contact angle symbol C or D is added after the bore number. For normal-angle tapered roller bearings, no contact angle symbol is used. Medium-angle tapered roller bearings are primarily used for the pinion shafts of differential gears of automobiles.

Among those with high load capacity(HR series), some bearings have the basic number suffixed by J to conform to the specifications of ISO for the cup back face raceway diameter, cup width, and contact angle. Therefore, the cone assembly and cup of bearings with the same basic number suffixed by J are internationally interchangeable.

Among metric-design tapered roller bearings specified by ISO 355, there are those having new dimensions that are different than the dimension series 3XX used in the past. Part of them are listed in the bearing tables. They conform to the specifications of ISO for the smaller end diameter of the cup and contact angle. The cone and cup assemblies are internationally interchangeable. The bearing number formulation, which is different than that for past metric design, is as follows:

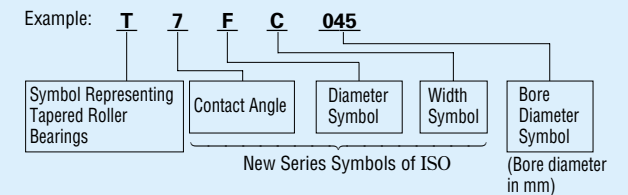

Besides metric design tapered roller bearings, there are also inch design bearings. For the cone assemblies and cups of inch design bearings, except four-row tapered roller bearings, the bearing numbers are approximately formulated as follows:

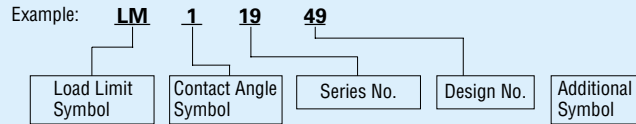

For tapered roller bearings, besides single-row bearings, there are also various combinations of bearings. The cages of tapered roller bearings are usually pressed steel.

**Table 1 Design and Featured of Combinations of Tapered Roller Bearings**

Figure	Arrangement	Examples of Bearing No.	Features
	Back-to-back	HR30210JDB+KLR10	Two standard bearings are combined. The bearing clearances are adjusted by cone spacers or cup spacers. The cones and cups and spacers are marked with serial numbers and mating marks. Components with the same serial number can be assembled referring to the matching symbols.
	Face-to-face	HR30210JDF+KR	
	KBE Type	100KBE31+L	The KBE type is a back-to-back arrangement of bearings with the cup and spacer integrated, and the KH type is a face-to-face arrangement in which the cones are integrated. Since the bearing clearance is adjusted using spacers, it is necessary for components to have the same serial number for assembly with reference to matching symbols.
	KH Type	110KH31+K	

**TOLERANCES AND RUNNING ACCURACY**

**METRIC DESIGN TAPERED ROLLER BEARINGS** ..... Table 8.3 (Pages A64~A67)

**INCH DESIGN TAPERED ROLLER BEARINGS** ..... Table 8.4 (Pages A68~A69)

Among inch design tapered roller bearings, there are those to which the following precision classes apply. For more details, please consult with NSK.

(1) J line bearings(in the bearing tables, bearings preceded by ▲)

**Table 2 Tolerances for Cones(CLASS K)**

Units :  $\mu\text{m}$

Nominal Bore Diameter $d$ (mm)		$\Delta d_{mp}$		$V_{dp}$	$V_{dmp}$	$K_{ia}$
over	incl	high	low	max	max	max
10	18	0	-12	12	9	15
18	30	0	-12	12	9	18
30	50	0	-12	12	9	20
50	80	0	-15	15	11	25
80	120	0	-20	20	15	30
120	180	0	-25	25	19	35
180	250	0	-30	30	23	50
250	315	0	-35	35	26	60
315	400	0	-40	40	30	70

**Table 3 Tolerances for Cups(CALSS K)**

Units :  $\mu\text{m}$

Nominal Outside Diameter $D$ (mm)		$\Delta D_{mp}$		$V_{Dp}$	$V_{Dmp}$	$K_{ea}$
over	incl	high	low	max	max	max
18	30	0	-12	12	9	18
30	50	0	-14	14	11	20
50	80	0	-16	16	12	25
80	120	0	-18	18	14	35
120	150	0	-20	20	15	40
150	180	0	-25	25	19	45
180	250	0	-30	30	23	50
250	315	0	-35	35	26	60
315	400	0	-40	40	30	70
400	500	0	-45	45	34	80

**Table 4 Tolerances for Effective Widths of Cone Assemblies and Cups, and Overall Width (CLASS K)**

Units :  $\mu\text{m}$

Nominal Bore Diameter $d$ (mm)		Effective Width Deviation of Cone Assembly $\Delta T_{1s}$		Effective Width Deviation of Cup $\Delta T_{2s}$		Overall Width Deviation $\Delta T_s$	
over	incl	high	low	high	low	high	low
10	80	+100	0	+100	0	+200	0
80	120	+100	-100	+100	-100	+200	-200
120	315	+150	-150	+200	-100	+350	-250
315	400	+200	-200	+200	-200	+400	-400

(2) Bearings for Front Axles of Automobiles  
(In the bearing tables, those preceded by t)

**Table 5 Tolerances for Bore Diameter and Overall Width**

Units :  $\mu\text{m}$

Nominal Bore Diameter $d$				Bore Diameter Deviation $\Delta d_s$		Overall Width Deviation $\Delta T_s$	
over	incl		incl	hig	hlow	hig	hlow
(mm)	1/25.4	(mm)	1/25.4				
—		76.200	3.0000	+20	0	+356	0

The tolerances for outside diameter and those for radial runout of the cones and cups conform to Table 8.4.2 (Pages A68 and A69).

(3) Special Chamfer Dimensions

For bearings marked "spec." in the column of  $r$  in the bearing tables, the chamfer dimension of the cone back-face side is as shown on the following figure.

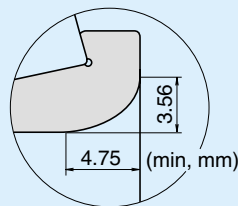

**RECOMMENDED FITS**

**METRIC DESIGN TAPERED ROLLER BEARINGS** ..... Table 9.2 (Page A84)  
Table 9.4 (Page A85)

**INCH DESIGN TAPERED ROLLER BEARINGS** ..... Table 9.6 (Page A86)  
Table 9.7 (Page A87)

**INTERNAL CLEARANCE**

**METRIC DESIGN TAPERED ROLLER BEARINGS**  
(Matched and Double-Row) ..... Table 9.16 (Page A93)  
**INCH DESIGN TAPERED ROLLER BEARINGS**  
(Matched and Double-Row) ..... Table 9.16 (Page A93)

**DIMENSIONS RELATED TO MOUNTING**

The dimensions related to mounting tapered roller bearings are listed in the bearing tables. Since the cages protrude from the ring faces of tapered roller bearings, please use care when designing shafts and housings.  
When heavy axial loads are imposed, the shaft shoulder dimensions and strength must be sufficient to support the cone rib.

**PERMISSIBLE MISALIGNMENT**

The permissible misalignment angle for tapered roller bearings is approximately 0.0009 radian (3').

**LIMITING SPEEDS**

The limiting speeds listed in the bearing tables should be adjusted depending on the bearing load conditions. Also, higher speeds are attainable by making changes in the lubrication method, cage design, etc. Refer to Page A37 for detailed information.

**PRECAUTIONS FOR USE OF TAPERED ROLLER BEARINGS**

1. If the load on tapered roller bearings becomes too small, or if the ratio of the axial and radial loads for matched bearings exceeds 'e' (e is listed in the bearing tables) during operation, slippage between the rollers and raceways occurs, which may result in smearing. Especially with large bearings since the weight of the rollers and cage is high. If such load conditions are expected, please contact NSK for selection of the bearings.
2. Confirm the dimension of "Abutment and Fillet Dimensions" of  $D_a$ ,  $D_b$ ,  $S_a$ ,  $S_b$  at the time of the HR series adoption.

Bore Diameter 15~28 mm

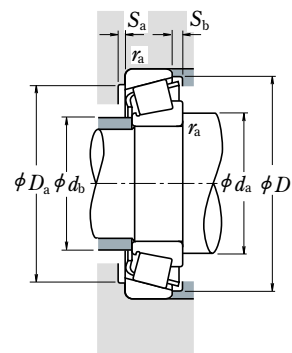
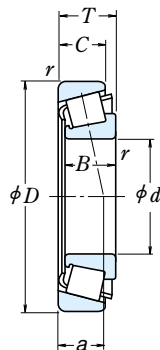

Dynamic Equivalent Load

$$P = XF_r + YF_a$$

$F_a/F_r \leq e$		$F_a/F_r > e$	
X	Y	X	Y
1	0	0.4	$Y_1$

Static Equivalent Load

$$P_0 = 0.5F_r + Y_0F_a$$

When  $F_r > 0.5F_r + Y_0F_a$ , use  $P_0 = F_r$

The values of  $e$ ,  $Y_1$ , and  $Y_0$  are given in the table below.

Boundary Dimensions (mm)							Basic Load Ratings				Limiting Speeds (rpm)	
$d$	$D$	$T$	$B$	$C$	Cone	Cup	(N)		(kgf)		Grease	Oil
					$r_{min}$	$r_{max}$	$C_r$	$C_{0r}$	$C_r$	$C_{0r}$		
15	35	11.75	11	10	0.6	0.6	14 800	13 200	1 510	1 350	11 000	15 000
	42	14.25	13	11	1	1	23 600	21 100	2 400	2 160	9 500	13 000
17	40	13.25	12	11	1	1	20 100	19 900	2 050	2 030	9 500	13 000
	40	17.25	16	14	1	1	27 100	28 000	2 770	2 860	9 500	13 000
	47	15.25	14	12	1	1	29 200	26 700	2 980	2 720	8 500	12 000
	47	15.25	14	10.5	1	1	22 000	20 300	2 240	2 070	8 000	11 000
20	47	20.25	19	16	1	1	37 500	36 500	3 800	3 750	8 500	11 000
	42	15	15	12	0.6	0.6	24 600	27 400	2 510	2 800	9 000	12 000
22	47	15.25	14	12	1	1	27 900	28 500	2 850	2 900	8 000	11 000
	47	15.25	14	12	0.3	1	23 900	24 000	2 430	2 450	8 000	11 000
	47	19.25	18	15	1	1	35 500	37 500	3 650	3 850	8 500	11 000
	47	19.25	18	15	1	1	31 500	33 500	3 200	3 400	8 000	11 000
	52	16.25	15	13	1.5	1.5	35 000	33 500	3 550	3 400	7 500	10 000
	52	16.25	15	12	1.5	1.5	25 300	24 500	2 580	2 490	7 100	10 000
	52	22.25	21	18	1.5	1.5	45 500	47 500	4 650	4 850	8 000	11 000
	44	15	15	11.5	0.6	0.6	25 600	29 400	2 610	3 000	8 500	11 000
	50	15.25	14	12	1	1	29 200	30 500	2 980	3 150	7 500	10 000
	50	15.25	14	12	1	1	27 200	29 500	2 780	3 000	7 500	10 000
	50	19.25	18	15	1	1	36 500	40 500	3 750	4 100	7 500	11 000
	50	19.25	18	15	1	1	33 500	39 500	3 400	4 000	7 500	10 000
25	56	17.25	16	14	1.5	1.5	37 000	36 500	3 750	3 750	7 100	9 500
	56	17.25	16	13	1.5	1.5	34 500	34 000	3 500	3 500	6 700	9 500
	47	15	15	11.5	0.6	0.6	27 400	33 000	2 800	3 400	8 000	11 000
	47	17	17	14	0.6	0.6	31 000	38 000	3 150	3 900	8 000	11 000
	52	16.25	15	13	1	1	32 000	35 000	3 300	3 550	7 100	10 000
	52	16.25	15	12	1	1	28 100	31 500	2 860	3 200	9 700	9 500
	52	19.25	18	16	1	1	40 000	45 000	4 050	4 600	7 100	10 000
	52	19.25	18	15	1	1	35 000	42 000	3 550	4 250	7 100	9 500
	52	22	22	18	1	1	47 500	56 500	4 850	5 750	7 500	10 000
	62	18.25	17	15	1.5	1.5	47 500	46 000	4 850	4 700	6 300	8 500
	62	18.25	17	14	1.5	1.5	42 000	45 000	4 300	4 550	6 000	8 500
	62	18.25	17	13	1.5	1.5	38 000	40 500	3 900	4 100	5 600	8 000
28	62	18.25	17	13	1.5	1.5	38 000	40 500	3 900	4 100	5 600	8 000
	62	25.25	24	20	1.5	1.5	62 500	66 000	6 400	6 750	6 300	8 500
	52	16	16	12	1	1	32 000	39 000	3 300	3 950	7 100	9 500
	58	17.25	16	14	1	1	39 500	41 500	4 050	4 200	6 300	9 000
	58	17.25	16	12	1	1	34 000	38 500	3 450	3 900	6 300	8 500
	58	20.25	19	16	1	1	47 500	54 000	4 850	5 500	6 300	9 000
	58	20.25	19	16	1	1	42 000	49 500	4 300	5 050	6 300	9 000
	68	19.75	18	15	1.5	1.5	55 000	55 500	5 650	5 650	6 000	8 000
	68	19.75	18	14	1.5	1.5	49 500	50 500	5 000	5 150	5 600	7 500

Bearing Numbers	ISO355 Dimension Series approx	Abutment and Fillet Dimensions (mm)								Eff. Load Centers (mm) $a$	Constant $e$	Axial Load Factors		Mass (kg) approx	
		$d_a$ min	$d_b$ max	$D_a$ max	$D_b$ min	$S_a$ min	$S_b$ min	Cone $r_a$ max	Cup $r_a$ max			$Y_1$	$Y_0$		
30202	—	23	19	30	30	33	2	1.5	0.6	0.6	8.2	0.32	1.9	1.0	0.053
HR 30302 J	2FB	24	22	36	36	38.5	2	3	1	1	9.5	0.29	2.1	1.2	0.098
HR 32023 J	2DB	26	23	34	34	37.5	2	2	1	1	9.7	0.35	1.7	0.96	0.079
HR 32203 J	2DD	26	22	34	34	37	2	3	1	1	11.2	0.31	1.9	1.1	0.103
HR 30303 J	2FB	26	24	41	40	43	2	3	1	1	10.4	0.29	2.1	1.2	0.134
30303 D	—	29	23	41	34	44	2	4.5	1	1	15.4	0.81	0.74	0.41	0.129
HR 32303 J	2FD	28	23	41	39	43	2	4	1	1	12.5	0.29	2.1	1.2	0.178
HR 32004 XJ	3CC	28	24	37	35	40	3	3	0.6	0.6	10.6	0.37	1.6	0.88	0.097
HR 32024 J	2DB	29	27	41	40	44	2	3	1	1	11.0	0.35	1.7	0.96	0.127
HR 30204 C-A-	—	29	26	41	37	44	2	3	0.3	1	13.0	0.55	1.1	0.60	0.126
HR 32204 J	2DD	29	25	41	38	44.5	3	4	1	1	12.6	0.33	1.8	1.0	0.161
HR 32204 CJ	5DD	29	25	41	36	44	2	4	1	1	14.5	0.52	1.2	0.64	0.166
HR 30304 J	2FB	31	27	44	44	47.5	2	3	1.5	1.5	11.6	0.30	2.0	1.1	0.172
30304 D	—	34	26	43	37	49	2	4	1.5	1.5	16.7	0.81	0.74	0.41	0.168
HR 32304 J	2FD	33	26	43	42	48	3	4	1.5	1.5	13.9	0.30	2.0	1.1	0.241
HR 320/22 XJ	3CC	30	27	39	37	42	3	3.5	0.6	0.6	11.1	0.40	1.5	0.83	0.103
HR 302/22	—	31	29	44	42	47	2	3	1	1	11.6	0.37	1.6	0.90	0.139
HR 302/22 C	—	31	29	44	40	47	2	3	1	1	13.0	0.49	1.2	0.67	0.144
HR 322/22	—	31	28	44	41	47	2	4	1	1	13.5	0.37	1.6	0.89	0.18
HR 322/22 C	—	31	29	44	39	48	2	4	1	1	15.2	0.51	1.2	0.65	0.185
HR 303/22	—	33	30	47	46	50	2	3	1.5	1.5	12.4	0.32	1.9	1.0	0.208
HR 303/22 C	—	33	30	47	44	52.5	3	4	1.5	1.5	15.9	0.59	1.0	0.56	0.207
HR 32005 XJ	4CC	33	30	42	40	45	3	3.5	0.6	0.6	11.8	0.43	1.4	0.77	0.116
HR 33005 J	2CE	33	29	42	41	44	3	3	0.6	0.6	11.0	0.29	2.1	1.1	0.131
HR 30205 J	3CC	34	31	46	44	48.5	2	3	1	1	12.7	0.38	1.6	0.88	0.157
HR 30205 C	—	34	32	46	43	49.5	2	4	1	1	14.4	0.53	1.1	0.62	0.155
HR 32205 J	2CD	34	30	46	44	50	2	3	1	1	13.5	0.36	1.7	0.92	0.189
HR 32205 C	—	34	30	46	40	50	2	4	1	1	15.8	0.53	1.1	0.62	0.19
HR 33205 J	2DE	34	29	46	43	49.5	4	4	1	1	14.1	0.35	1.7	0.94	0.221
HR 30305 J	2FB	36	34	54	54	57	2	3	1.5	1.5	13.2	0.30	2.0	1.1	0.27
HR 30305 C	—	36	35	53	49	58.5	3	4	1.5	1.5	16.4	0.55	1.1	0.60	0.276
HR 30305 DJ	(7FB)	39	34	53	47	59	2	5	1.5	1.5	19.9	0.83	0.73	0.40	0.265
HR 31305 J	7FB	39	33	53	47	59	3	5	1.5	1.5	19.9	0.83	0.73	0.40	0.265
HR 32305 J	2FD	38	32	53	51	57	3	5	1.5	1.5	15.6	0.30	2.0	1.1	0.376
HR 320/28 XJ	4CC	37	33	46	44	50	3	4	1	1	12.8	0.43	1.4	0.77	0.146
HR 302/28	—	37	34	52	50	55	2	3	1	1	13.2	0.35	1.7	0.93	0.203
HR 302/28 C	—	37	34	52	48	54	2	5	1	1	16.9	0.64	0.94	0.52	0.198
HR 322/28	—	37	34	52	49	55	2	4	1	1	14.6	0.37	1.6	0.89	0.243
HR 322/28 CJ	5DD	37													

Bore Diameter 30~35 mm

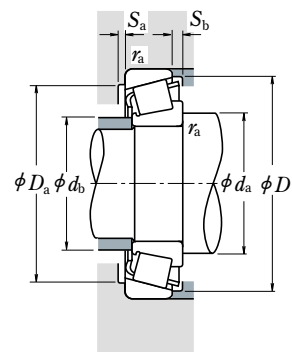
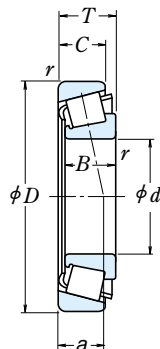

Dynamic Equivalent Load

$$P = XF_r + YF_a$$

$F_a/F_r \leq e$		$F_a/F_r > e$	
X	Y	X	Y
1	0	0.4	$Y_1$

Static Equivalent Load

$$P_0 = 0.5F_r + Y_0F_a$$

When  $F_r > 0.5F_r + Y_0F_a$ , use  $P_0 = F_r$

The values of  $e$ ,  $Y_1$ , and  $Y_0$  are given in the table below.

d	Boundary Dimensions (mm)				Cone		Basic Load Ratings (N) / (kgf)				Limiting Speeds (rpm)		
	D	T	B	C	r	r <sub>min</sub>	C <sub>r</sub>	C <sub>0r</sub>	C <sub>r</sub>	C <sub>0r</sub>	Grease	Oil	
30	47	12	12	9	0.3	0.3	17 600	24 400	1 800	2 490	7 500	10 000	
	55	17	17	13	1	1	36 000	44 500	3 700	4 550	6 700	9 000	
	55	20	20	16	1	1	42 000	54 000	4 250	5 500	6 700	9 000	
	62	17.25	16	14	1	1	43 000	47 500	4 400	4 850	6 000	8 000	
	62	17.25	16	12	1	1	35 500	37 000	3 650	3 800	5 600	7 500	
	62	21.25	20	17	1	1	52 000	60 000	5 300	6 150	6 000	8 500	
	62	21.25	20	16	1	1	48 000	56 000	4 900	5 750	6 000	8 000	
	62	25	25	19.5	1	1	66 500	79 500	6 800	8 100	6 000	8 000	
	72	20.75	19	16	1.5	1.5	59 500	60 000	6 050	6 100	5 300	7 500	
	72	20.75	19	14	1.5	1.5	56 500	55 500	5 800	5 650	5 300	7 100	
	72	20.75	19	14	1.5	1.5	49 000	52 500	5 000	5 350	4 800	6 700	
	72	20.75	19	14	1.5	1.5	49 000	52 500	5 000	5 350	4 800	6 800	
72	28.75	27	23	1.5	1.5	80 000	88 500	8 150	9 000	5 600	7 500		
72	28.75	27	23	1.5	1.5	76 000	86 500	7 750	8 800	5 600	7 500		
32	58	17	17	13	1	1	37 500	47 000	3 800	4 800	6 300	8 500	
	58	21	20	16	1	1	41 000	50 000	4 150	5 100	6 300	8 500	
	65	18.25	17	15	1	1	48 500	54 000	4 950	5 500	5 600	8 000	
	65	18.25	17	14	1	1	45 500	52 500	4 650	5 350	5 600	7 500	
	65	22.25	21	18	1	1	56 000	65 000	5 700	6 650	6 000	8 000	
	65	22.25	21	17	1	1	49 500	60 000	5 050	6 100	5 600	7 500	
	65	26	26	20.5	1	1	70 000	86 500	7 150	8 850	5 600	8 000	
	75	21.75	20	17	1.5	1.5	56 000	56 000	5 700	5 700	5 300	7 100	
	35	55	14	14	11.5	0.6	0.6	27 400	39 000	2 790	3 950	6 300	8 500
		62	18	18	14	1	1	43 500	55 500	4 400	5 650	5 600	8 000
62		21	21	17	1	1	49 000	65 000	4 950	6 650	5 600	8 000	
72		18.25	17	15	1.5	1.5	54 000	59 500	5 500	6 050	5 300	7 100	
72		18.25	17	13	1.5	1.5	47 000	54 500	4 750	5 550	5 000	6 700	
72		24.25	23	19	1.5	1.5	70 500	83 500	7 150	8 550	5 300	7 100	
72		24.25	23	18	1.5	1.5	60 500	71 500	6 200	7 300	5 000	7 100	
72		28	28	22	1.5	1.5	86 500	108 000	8 850	11 100	5 300	7 100	
80		22.75	21	18	2	1.5	76 000	79 000	7 750	8 050	4 800	6 700	
80		22.75	21	16	2	1.5	68 000	70 500	6 900	7 200	4 800	6 300	
80		22.75	21	15	2	1.5	62 000	68 000	6 350	6 950	4 300	6 000	
80		22.75	21	15	2	1.5	62 000	68 000	6 350	6 950	4 300	6 000	
80	32.75	31	25	2	1.5	99 000	111 000	10 100	11 300	5 000	6 700		

Bearing Numbers	ISO355 Dimension Series approx	Abutment and Fillet Dimensions (mm)								Eff. Load Centers (mm) a	Constant e	Axial Load Factors		Mass (kg) approx	
		d <sub>a</sub> min	d <sub>b</sub> max	D <sub>a</sub> max	D <sub>b</sub> min	S <sub>a</sub> min	S <sub>b</sub> min	Cone r <sub>a</sub> max	Cup r <sub>a</sub> min			Y <sub>1</sub>	Y <sub>0</sub>		
HR 32906 J HR 32006 XJ HR 33006 J	2BD	34	34	44	42	44	3	3	0.3	0.3	9.2	0.32	1.9	1.0	0.074
	4CC	39	35	49	47	53	3	4	1	1	13.5	0.43	1.4	0.77	0.172
	2CE	39	35	49	48	52	3	4	1	1	13.1	0.29	2.1	1.1	0.208
HR 30206 J HR 30206 C HR 32206 J	3DB	39	37	56	52	58	2	3	1	1	13.9	0.38	1.6	0.88	0.238
	—	39	36	56	49	59	2	5	1	1	17.8	0.68	0.88	0.49	0.221
	3DC	39	36	56	51	58.5	2	4	1	1	15.4	0.38	1.6	0.88	0.297
HR 32206 C HR 32206 J HR 30306 J HR 30306 C	—	39	35	56	48	59	2	5	1	1	17.8	0.55	1.1	0.60	0.293
	2DE	39	35	56	52	59.5	5	5.5	1	1	16.1	0.34	1.8	0.97	0.355
	2FB	41	40	63	62	66	3	4.5	1.5	1.5	15.1	0.32	1.9	1.1	0.403
HR 30306 C HR 30306 DJ HR 31306 J HR 32306 J HR 32306 CJ	—	41	38	63	59	67	3	6.5	1.5	1.5	18.5	0.55	1.1	0.60	0.383
	(7FB)	44	40	63	55	68	3	6.5	1.5	1.5	23.1	0.83	0.73	0.40	0.393
	7FB	44	40	63	55	68	3	6.5	1.5	1.5	23.1	0.83	0.73	0.40	0.393
HR 32306 J HR 32306 CJ	2FD	43	38	63	59	66	3	5.5	1.5	1.5	18.0	0.32	1.9	1.1	0.57
	5FD	43	36	63	54	68	3	5.5	1.5	1.5	22.0	0.55	1.1	0.60	0.583
	—	43	36	63	54	68	3	5.5	1.5	1.5	22.0	0.55	1.1	0.60	0.583
HR 320/32 XJ 330/32 HR 302/32 HR 302/32 C	4CC	41	37	52	49	55	3	4	1	1	14.2	0.45	1.3	0.73	0.191
	—	41	37	52	50	55	2	4	1	1	13.8	0.31	1.9	1.1	0.225
	—	41	39	59	56	61	3	3	1	1	14.7	0.37	1.6	0.88	0.277
HR 302/32 C HR 322/32 HR 322/32 C HR 332/32 J 303/32	—	41	39	59	54	62	3	4	1	1	16.9	0.55	1.1	0.60	0.273
	—	41	38	59	54	61	3	4	1	1	15.9	0.37	1.6	0.88	0.336
	—	41	39	59	51	62	3	5	1	1	20.2	0.59	1.0	0.56	0.335
HR 332/32 J 303/32	2DE	41	38	59	55	62	5	5.5	1	1	17.0	0.35	1.7	0.95	0.40
	—	44	42	66	64	68	3	4.5	1.5	1.5	15.9	0.33	1.8	1.0	0.435
	—	44	42	66	64	68	3	4.5	1.5	1.5	15.9	0.33	1.8	1.0	0.435
HR 32907 J HR 32007 XJ HR 33007 J	2BD	43	40	50	50	52.5	3	2.5	0.6	0.6	10.7	0.29	2.1	1.1	0.123
	4CC	44	40	56	54	60	4	4	1	1	15.0	0.45	1.3	0.73	0.229
	2CE	44	40	56	55	59	4	4	1	1	14.1	0.31	2.0	1.1	0.267
HR 30207 J HR 30207 C HR 32207 J	3DB	46	43	63	62	67	3	3	1.5	1.5	15.0	0.38	1.6	0.88	0.34
	—	46	44	63	59	68	3	5	1.5	1.5	19.6	0.66	0.91	0.50	0.331
	3DC	46	42	63	61	67.5	3	5	1.5	1.5	17.9	0.38	1.6	0.88	0.456
HR 32207 C HR 33207 J HR 30307 J	—	46	42	63	58	68.5	3	6	1.5	1.5	20.6	0.55	1.1	0.60	0.442
	2DE	46	41	63	61	68	5	6	1.5	1.5	18.3	0.35	1.7	0.93	0.54
	2FB	47	45	71	69	74	3	4.5	2	1.5	16.7	0.32	1.9	1.1	0.538
HR 30307 C HR 30307 DJ HR 31307 J HR 32307 J	—	47	44	71	65	74	3	6.5	2	1.5	20.3	0.55	1.1	0.60	0.518
	7FB	51	44	71	62	77	3	7.5	2	1.5	25.2	0.83	0.73	0.40	0.519
	7FB	51	44	71	62	77	3	7.5	2	1.5	25.2	0.83	0.73	0.40	0.52
	2FE	49	43	71	66	74	3	7.5	2	1.5	20.7	0.32	1.9	1.1	0.765

Remarks The suffix C represents medium-angle tapered roller bearings. Since they are designed for specific applications, please consult NSK when using bearings with suffix C.

Bore Diameter 40~50 mm

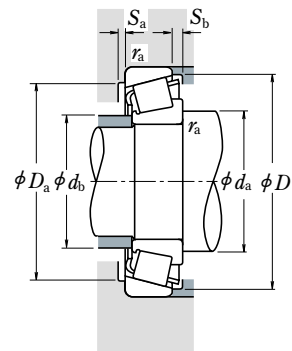
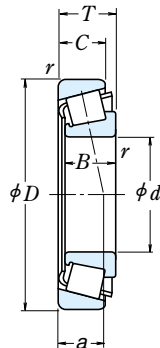

Dynamic Equivalent Load

$$P = XF_r + YF_a$$

$F_a/F_r \leq e$		$F_a/F_r > e$	
X	Y	X	Y
1	0	0.4	$Y_1$

Static Equivalent Load

$$P_0 = 0.5F_r + Y_0F_a$$

When  $F_r > 0.5F_r + Y_0F_a$ , use  $P_0 = F_r$

The values of  $e$ ,  $Y_1$ , and  $Y_0$  are given in the table below.

d	Boundary Dimensions (mm)					Basic Load Ratings (N) {kgf}				Limiting Speeds (rpm)	
	D	T	B	C	r	C <sub>r</sub>	C <sub>0r</sub>	C <sub>r</sub>	C <sub>0r</sub>	Grease	Oil
40	62	15	15	12	0.6	34 000	47 000	3 450	4 800	5 600	7 500
	68	19	19	14.5	1	53 000	71 000	5 400	7 250	5 300	7 100
	68	22	22	18	1	59 000	81 500	6 000	8 300	5 300	7 100
	75	26	26	20.5	1.5	78 500	101 000	8 000	10 300	4 800	6 700
	80	19.75	18	16	1.5	63 500	70 000	6 450	7 150	4 800	6 300
	80	24.75	23	19	1.5	77 000	90 500	7 900	9 200	4 800	6 300
	80	24.75	23	19	1.5	74 000	90 500	7 550	9 200	4 500	6 300
	80	32	32	25	1.5	107 000	137 000	10 900	14 000	4 800	6 300
	90	25.25	23	20	2	90 500	101 000	9 250	10 300	4 300	5 600
	90	25.25	23	18	2	84 500	93 500	8 600	9 500	4 300	5 600
	90	25.25	23	17	2	80 000	89 500	8 150	9 150	3 800	5 300
	90	25.25	23	17	2	80 000	89 500	8 150	9 150	3 800	5 300
90	35.25	33	27	2	120 000	145 000	12 200	14 800	4 300	6 000	
45	68	15	15	12	0.6	34 500	50 500	3 550	5 150	5 000	6 700
	75	20	20	15.5	1	60 000	83 000	6 150	8 450	4 500	6 300
	75	24	24	19	1	69 000	99 000	7 050	10 100	4 800	6 300
	80	26	26	20.5	1.5	84 000	113 000	8 550	11 600	4 500	6 000
	85	20.75	19	16	1.5	68 500	79 500	6 950	8 100	4 300	6 000
	85	24.75	23	19	1.5	83 000	102 000	8 500	10 400	4 300	6 000
	85	24.75	23	19	1.5	75 500	95 500	7 700	9 750	4 300	5 600
	85	32	32	25	1.5	111 000	147 000	11 300	15 000	4 300	6 000
	95	29	26.5	20	2.5	88 500	109 000	9 050	11 100	3 600	5 000
	95	36	35	30	2.5	139 000	174 000	14 200	17 800	4 000	5 300
	100	27.25	25	22	2	112 000	127 000	11 400	12 900	3 800	5 300
	100	27.25	25	18	2	95 500	109 000	9 750	11 100	3 400	4 800
50	100	27.25	25	18	2	95 500	109 000	9 750	11 100	3 400	4 800
	100	38.25	36	30	2	144 000	177 000	14 700	18 000	3 800	5 300
	30	36	35	30	2.5	144 000	185 000	14 600	18 800	3 800	5 000
	72	15	15	12	0.6	36 000	54 000	3 650	5 500	4 500	6 300
	80	20	20	15.5	1	61 000	87 000	6 250	8 900	4 300	6 000
	80	24	24	19	1	70 500	104 000	7 150	10 600	4 300	6 000
	85	26	26	20	1.5	89 000	126 000	9 100	12 800	4 300	5 600
	90	21.75	20	17	1.5	76 000	91 500	7 750	9 300	4 000	5 300
	90	24.75	23	19	1.5	87 500	109 000	8 900	11 100	4 000	5 300
	90	24.75	23	18	1.5	77 500	102 000	7 900	10 400	3 800	5 300
	90	32	32	24.5	1.5	118 000	165 000	12 100	16 800	4 000	5 300
	105	32	29	22	3	109 000	133 000	11 100	13 600	3 200	4 500
110	29.25	27	23	2.5	130 000	148 000	13 300	15 100	3 400	4 800	
110	29.25	27	19	2.5	114 000	132 000	11 700	13 400	3 200	4 300	
110	29.25	27	19	2.5	114 000	132 000	11 700	13 400	3 200	4 300	
110	42.25	40	33	2.5	176 000	220 000	17 900	22 400	3 600	4 800	
110	42.25	40	33	2.5	164 000	218 000	16 800	22 200	3 400	4 800	

Remarks The suffix C represents medium-angle tapered roller bearings. Since they are designed for specific applications, please consult NSK when using bearings with suffix C.

Bearing Numbers	ISO355 Dimension Series approx	Abutment and Fillet Dimensions (mm)						Cone Cup r <sub>a</sub> r <sub>b</sub>	Eff. Load Centers (mm) a	Constant e	Axial Load Factors		Mass (kg) approx		
		d <sub>a</sub> min	d <sub>b</sub> max	D <sub>a</sub> max	D <sub>b</sub> min	S <sub>a</sub> min	S <sub>b</sub> min				Y <sub>1</sub>	Y <sub>0</sub>			
HR 32908 J	2BC	48	44	57	57	59	3	3	0.6	0.6	11.5	0.29	2.1	1.1	0.161
HR 32008 XJ	3CD	49	45	62	60	65.5	4	4.5	1	1	15.0	0.38	1.6	0.87	0.28
HR 33008 J	2BE	49	45	62	61	65	4	4	1	1	14.6	0.28	2.1	1.2	0.322
HR 33108 J	2CE	51	46	66	65	71	4	5.5	1.5	1.5	18.0	0.36	1.7	0.93	0.503
HR 30208 J	3DB	51	48	71	69	75	3	3.5	1.5	1.5	16.6	0.38	1.6	0.88	0.437
HR 32208 J	3DC	51	48	71	68	75	3	5.5	1.5	1.5	18.9	0.38	1.6	0.88	0.548
HR 32208 CJ	5DC	51	47	71	65	76	3	5.5	1.5	1.5	21.9	0.55	1.1	0.60	0.558
HR 33208 J	2DE	51	46	71	67	76	5	7	1.5	1.5	20.8	0.36	1.7	0.92	0.744
HR 30308 J	2FB	52	52	81	76	82	3	5	2	1.5	19.5	0.35	1.7	0.96	0.758
HR 30308 C	—	52	50	81	72	84	3	7	2	1.5	22.7	0.53	1.1	0.62	0.735
HR 30308 DJ	7FB	56	50	81	70	87	3	8	2	1.5	28.7	0.83	0.73	0.40	0.728
HR 31308 J	7FB	56	50	81	70	87	3	8	2	1.5	28.7	0.83	0.73	0.40	0.728
HR 32308 J	2FD	54	50	81	73	82	3	8	2	1.5	23.4	0.35	1.7	0.96	1.05
HR 32909 J	2BC	53	50	63	62	64	3	3	0.6	0.6	12.3	0.32	1.9	1.0	0.187
HR 32009 XJ	3CC	54	51	69	67	72	4	4.5	1	1	16.6	0.39	1.5	0.84	0.354
HR 33009 J	2CE	54	51	69	67	71	4	5	1	1	16.3	0.29	2.0	1.1	0.414
HR 33109 J	3CE	56	51	71	69	77	4	5.5	1.5	1.5	19.1	0.38	1.6	0.86	0.552
HR 30209 J	3DB	56	53	76	74	80	3	4.5	1.5	1.5	18.3	0.41	1.5	0.81	0.488
HR 32209 J	3DC	56	53	76	73	81	3	5.5	1.5	1.5	20.1	0.41	1.5	0.81	0.602
HR 32209 CJ	5DC	56	52	76	70	82	3	5.5	1.5	1.5	23.6	0.59	1.0	0.56	0.603
HR 33209 J	3DE	56	51	76	72	81	5	7	1.5	1.5	22.0	0.39	1.6	0.86	0.817
T 7 FC045	7FC	60	53	83	71	91	3	9	2	2	32.1	0.87	0.69	0.38	0.918
T 2 ED045	2ED	60	54	83	79	89	5	6	2	2	23.5	0.32	1.9	1.02	1.22
HR 30309 J	2FB	57	58	91	86	93	3	5	2	1.5	21.1	0.35	1.7	0.96	1.01
HR 30309 DJ	7FB	61	57	91	79	96	3	9	2	1.5	31.5	0.83	0.73	0.40	0.957
HR 31309 J	7FB	61	57	91	79	96	3	9	2	1.5	31.5	0.83	0.73	0.40	0.947
HR 32309 J	2FD	59	56	91	82	93	3	8	2	1.5	25.0	0.35	1.7	0.96	1.42
T 2 ED050	2ED	65	59	88	83	94	6	6	2	2	24.2	0.34	1.8	0.96	1.3
HR 32910 J	2BC	58	54	67	66	69	3	3	0.6	0.6	13.5	0.34	1.8	0.97	0.193
HR 32010 XJ	3CC	59	56	74	71	77	4	4.5	1	1	17.9	0.42	1.4	0.78	0.38
HR 33010 J	2CE	59	55	74	71	76	4	5	1	1	17.4	0.32	1.9	1.0	0.452
HR 33110 J	3CE	61	56	76	74	82	4	6	1.5	1.5	20.3	0.41	1.5	0.8	0.597
HR 30210 J	3DB	61	58	81	79	85	3	4.5	1.5	1.5	19.6	0.42	1.4	0.79	0.557
HR 32210 J	3DC	61	57	81	78	86	3	5.5	1.5	1.5	21.0	0.42	1.4	0.79	0.642
HR 32210 CJ	5DC	61	58	81	76	87	3	6.5	1.5	1.5	24.6	0.59	1.0	0.56	0.655
HR 33210 J	3DE	61	56	81	76	87	5	7.5	1.5	1.5	23.2	0.41	0.5	0.80	0.867
T 7 FC050	7FC	74	59	91	78	100	5	10	2.5	2.5	36.4	0.87	0.69	0.38	1.22
HR 30310 J	2FB	65	65	100	95	102	3	6	2	2	23.1	0.35	1.7	0.96	1.28
HR 30310 DJ	7FB	70	62	100	87	105	3	10	2	2	34.2	0.83	0.73	0.40	1.26
HR 31310 J	7FB	70	62	100	87	105	3	10	2	2	34.2	0.83	0.73	0.40	1.26
HR 32310 J	2FD	68	62	100	91	102	3	9	2	2	27.9	0.35	1.7	0.96	1.88
HR 32310 CJ	5FD	68	59	100	82	103	3	9	2	2	32.8	0.55	1.1	0.60	1.93



Bore Diameter 55~65 mm

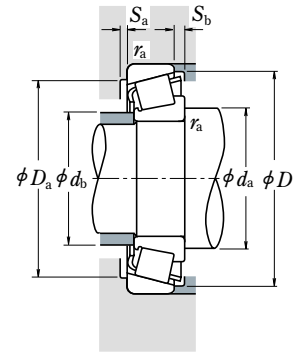
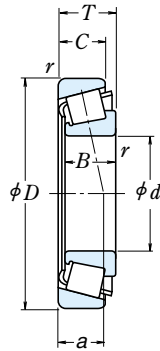

Dynamic Equivalent Load

$$P = XF_r + YF_a$$

$F_a/F_r \leq e$		$F_a/F_r > e$	
X	Y	X	Y
1	0	0.4	$Y_1$

Static Equivalent Load

$$P_0 = 0.5F_r + Y_0F_a$$

When  $F_r > 0.5F_r + Y_0F_a$ , use  $P_0 = F_r$

The values of  $e$ ,  $Y_1$ , and  $Y_0$  are given in the table below.

d	Boundary Dimensions (mm)				Cone		Basic Load Ratings				Limiting Speeds (rpm)	
	D	T	B	C	r	r <sub>min</sub>	C <sub>r</sub>	C <sub>0r</sub>	C <sub>r</sub>	C <sub>0r</sub>	Grease	Oil
55	80	17	17	14	1	1	45 500	74 500	4 600	7 600	4 300	5 600
	90	23	23	17.5	1.5	1.5	81 500	117 000	8 300	11 900	3 800	5 300
	90	27	27	21	1.5	1.5	91 500	138 000	9 300	14 000	3 800	5 300
	95	30	30	23	1.5	1.5	112 000	158 000	11 500	16 100	3 800	5 000
	100	22.75	21	18	2	1.5	94 500	113 000	9 650	11 500	3 600	5 000
	100	26.75	25	21	2	1.5	110 000	137 000	11 200	14 000	3 600	5 000
	100	35	35	27	2	1.5	141 000	193 000	14 400	19 700	3 600	5 000
	115	34	31	23.5	3	3	126 000	164 000	12 800	16 700	3 000	4 300
	120	31.5	29	25	2.5	2	150 000	171 000	15 200	17 500	3 200	4 300
	120	31.5	29	21	2.5	2	131 000	153 000	13 400	15 600	2 800	4 000
	120	31.5	29	21	2.5	2	131 000	153 000	13 400	15 600	2 800	4 000
	120	45.5	43	35	2.5	2	204 000	258 000	20 800	26 300	3 200	4 300
120	45.5	43	35	2.5	2	195 000	262 000	19 900	26 700	3 200	4 300	
60	85	17	17	14	1	1	49 000	84 500	5 000	8 650	3 800	5 300
	95	23	23	17.5	1.5	1.5	85 500	127 000	8 700	12 900	3 600	5 000
	95	27	27	21	1.5	1.5	96 000	150 000	9 800	15 300	3 600	5 000
	100	30	30	23	1.5	1.5	115 000	166 000	11 700	16 900	3 400	4 800
	110	23.75	22	19	2	1.5	104 000	123 000	10 600	12 500	3 400	4 500
	110	29.75	28	24	2	1.5	131 000	167 000	13 400	17 000	3 400	4 500
	110	38	38	29	2	1.5	166 000	231 000	16 900	23 600	3 400	4 500
	125	37	33.5	26	3	3	151 000	197 000	15 400	20 100	2 800	3 800
	130	33.5	31	26	3	2.5	174 000	201 000	17 700	20 500	3 000	4 000
	130	33.5	31	22	3	2.5	151 000	177 000	15 400	18 100	2 600	3 800
	130	33.5	31	22	3	2.5	151 000	177 000	15 400	18 100	2 600	3 800
	130	48.5	46	37	3	2.5	233 000	295 000	23 700	30 000	3 000	4 000
130	48.5	46	35	3	2.5	196 000	249 000	20 000	25 400	2 800	3 800	
65	90	17	17	14	1	1	49 000	86 500	5 000	8 800	3 600	5 000
	100	23	23	17.5	1.5	1.5	86 500	132 000	8 800	13 500	3 400	4 500
	100	27	27	21	1.5	1.5	97 500	156 000	9 950	15 900	3 400	4 500
	110	34	34	26.5	1.5	1.5	148 000	218 000	15 100	22 200	3 200	4 300
	120	24.75	23	20	2	1.5	122 000	151 000	12 500	15 400	3 000	4 000
	120	32.75	31	27	2	1.5	157 000	202 000	16 000	20 600	3 000	4 000
	120	41	41	32	2	1.5	202 000	282 000	20 600	28 800	3 000	4 000
	140	36	33	28	3	2.5	200 000	233 000	20 400	23 800	2 600	3 600
	140	36	33	23	3	2.5	173 000	205 000	17 700	20 900	2 400	3 400
	140	36	33	23	3	2.5	173 000	205 000	17 700	20 900	2 400	3 400
	140	51	48	39	3	2.5	267 000	340 000	27 300	35 000	2 800	3 800

Remarks The suffix C represents medium-angle tapered roller bearings. Since they are designed for specific applications, please consult NSK when using bearings with suffix C.

Bearing Numbers	ISO355 Dimension Series approx	Abutment and Fillet Dimensions (mm)						Cone Cup		Eff. Load Centers (mm) a	Constant e	Axial Load Factors		Mass (kg) approx	
		d <sub>a</sub> min	d <sub>b</sub> max	D <sub>a</sub> max	D <sub>b</sub> min	S <sub>a</sub> min	S <sub>b</sub> min	r <sub>a</sub> max	r <sub>a</sub> min			Y <sub>1</sub>	Y <sub>0</sub>		
HR 32911 J	2BC	64	60	74	73	76	4	3	1	1	14.6	0.31	1.9	1.1	0.282
HR 32011 XJ	3CC	66	62	81	80	86	4	5.5	1.5	1.5	19.7	0.41	1.5	0.81	0.568
HR 33011 J	2CE	66	62	81	80	86	5	6	1.5	1.5	19.2	0.31	1.9	1.1	0.657
HR 33111 J	3CE	66	62	86	82	91	5	7	1.5	1.5	22.4	0.37	1.6	0.88	0.877
HR 30211 J	3DB	67	64	91	89	94	4	4.5	2	1.5	20.9	0.41	1.5	0.81	0.736
HR 32211 J	3DC	67	63	91	87	95	4	5.5	2	1.5	22.7	0.41	1.5	0.81	0.859
HR 33211 J	3DE	67	62	91	86	96	6	8	2	1.5	25.2	0.40	1.5	0.83	1.18
T 7 FC055	7FC	73	66	101	86	109	4	10.5	2.5	2.5	39.0	0.87	0.69	0.38	1.58
HR 30311 J	2FB	70	71	110	104	111	4	6.5	2	2	24.6	0.35	1.7	0.96	1.63
HR 30311 DJ	7FB	75	67	110	94	114	4	10.5	2	2	37.0	0.83	0.73	0.40	1.58
HR 31311 J	7FB	75	67	110	94	114	4	10.5	2	2	37.0	0.83	0.73	0.40	1.58
HR 32311 J	2FD	73	67	110	99	111	4	10.5	2	2	29.9	0.35	1.7	0.96	2.39
HR 32311 CJ	5FD	73	65	110	91	112	4	10.5	2	2	35.8	0.55	1.1	0.60	2.47
HR 32912 J	2BC	69	65	79	78	81	4	3	1	1	15.5	0.33	1.8	1.0	0.306
HR 32012 XJ	4CC	71	66	86	85	91	4	5.5	1.5	1.5	20.9	0.43	1.4	0.77	0.608
HR 33012 J	2CE	71	66	86	85	90	5	6	1.5	1.5	20.0	0.33	1.8	1.0	0.713
HR 33112 J	3CE	71	68	91	88	96	5	7	1.5	1.5	23.6	0.40	1.5	0.83	0.91
HR 30212 J	3EB	72	69	101	96	103	4	4.5	2	1.5	22.0	0.41	1.5	0.81	0.930
HR 32212 J	3EC	72	68	101	95	104	4	5.5	2	1.5	24.1	0.41	1.5	0.81	1.18
HR 33212 J	3EE	72	68	101	94	105	6	9	2	1.5	27.6	0.40	1.5	0.82	1.56
T 7 FC060	7FC	78	72	111	94	119	4	11	2.5	2.5	41.3	0.82	0.73	0.40	2.03
HR 30312 J	2FB	78	77	118	112	120	4	7.5	2.5	2	26.0	0.35	1.7	0.96	2.03
HR 30312 DJ	7FB	84	74	118	103	125	4	11.5	2.5	2	40.3	0.83	0.73	0.40	1.98
HR 31312 J	7FB	84	74	118	103	125	4	11.5	2.5	2	40.3	0.83	0.73	0.40	1.98
HR 32312 J	2FD	81	74	118	107	120	4	11.5	2.5	2	31.4	0.35	1.7	0.96	2.96
32312 C	—	81	74	116	102	125	4	13.5	2.5	2	39.9	0.58	1.0	0.57	2.86
HR 32913 J	2BC	74	70	84	82	86	4	3	1	1	16.8	0.35	1.7	0.93	0.323
HR 32013 XJ	4CC	76	71	91	90	97	4	5.5	1.5	1.5	22.4	0.46	1.3	0.72	0.646
HR 33013 J	2CE	76	71	91	90	96	5	6	1.5	1.5	21.1	0.35	1.7	0.95	0.76
HR 33113 J	3DE	76	73	101	96	106	6	7.5	1.5	1.5	26.0	0.39	1.5	0.85	1.32
HR 30213 J	3EB	77	78	111	106	113	4	4.5	2	1.5	23.8	0.41	1.5	0.81	1.18
HR 32213 J	3EC	77	75	111	104	115	4	5.5	2	1.5	27.1	0.41	1.5	0.81	1.55
HR 33213 J	3EE	77	74	111	102	115	6	9	2	1.5	29.2	0.39	1.5	0.85	2.04
HR 30313 J	2GB	83	83	128	121	130	4	8	2.5	2	27.9	0.35	1.7	0.96	2.51
HR 30313 DJ	7GB	89	80	128	111	133	4	13	2.5	2	43.2	0.83	0.73	0.40	2.43
HR 31313 J	7GB	89	80	128	111	133	4	13	2.5	2	43.2	0.83	0.73	0.40	2.43
HR 32313 J	2GD	86	80	128	116	130	4	12	2.5	2	34.0	0.35	1.7	0.96	3.6

Bore Diameter 70~80 mm

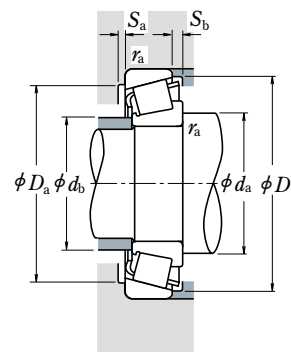
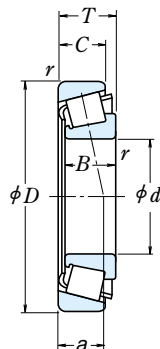

Dynamic Equivalent Load

$$P = XF_r + YF_a$$

$F_a/F_r \leq e$		$F_a/F_r > e$	
X	Y	X	Y
1	0	0.4	$Y_1$

Static Equivalent Load

$$P_0 = 0.5F_r + Y_0F_a$$

When  $F_r > 0.5F_r + Y_0F_a$ , use  $P_0 = F_r$

The values of  $e$ ,  $Y_1$ , and  $Y_0$  are given in the table below.

d	Boundary Dimensions (mm)				Cone r min	Cup r min	Basic Load Ratings				Limiting Speeds (rpm)	
	D	T	B	C			(N) C <sub>r</sub>	(kgf) C <sub>0r</sub>	C <sub>r</sub>	C <sub>0r</sub>	Grease	Oil
70	100	20	20	16	1	1	70 000	113 000	7 150	11 500	3 200	4 500
	110	25	25	19	1.5	1.5	104 000	158 000	10 600	16 100	3 200	4 300
	110	31	31	25.5	1.5	1.5	127 000	204 000	12 900	20 800	3 000	4 300
	120	37	37	29	2	1.5	177 000	262 000	18 100	26 700	3 000	4 000
	125	26.25	24	21	2	1.5	132 000	163 000	13 500	16 700	2 800	4 000
	125	33.25	31	27	2	1.5	157 000	205 000	16 100	20 900	2 800	4 000
	125	41	41	32	2	1.5	209 000	299 000	21 300	30 500	2 800	4 000
	140	39	35.5	27	3	3	177 000	229 000	18 000	23 400	2 400	3 400
	150	38	35	30	3	2.5	227 000	268 000	23 200	27 400	2 400	3 400
	150	38	35	25	3	2.5	192 000	229 000	19 600	23 300	2 200	3 200
75	105	20	20	16	1	1	72 500	120 000	7 400	12 300	3 200	4 300
	115	25	25	19	1.5	1.5	109 000	171 000	11 100	17 400	3 000	4 000
	115	31	31	25.5	1.5	1.5	133 000	220 000	13 500	22 500	3 000	4 000
	125	37	37	29	2	2	182 000	275 000	18 600	28 100	2 800	3 800
	130	27.25	25	22	2	1.5	143 000	182 000	14 600	18 500	2 800	3 800
	130	33.25	31	27	2	1.5	165 000	219 000	16 900	22 400	2 800	3 800
	130	41	41	31	2	1.5	215 000	315 000	21 900	32 000	2 800	3 800
	160	40	37	31	3	2.5	253 000	300 000	25 800	30 500	2 400	3 200
	160	40	37	26	3	2.5	211 000	251 000	21 500	25 600	2 200	3 000
	160	40	37	26	3	2.5	211 000	251 000	21 500	25 600	2 200	3 000
80	110	20	20	16	1	1	75 000	128 000	7 650	13 100	3 000	4 000
	125	29	29	22	1.5	1.5	140 000	222 000	14 300	22 700	2 800	3 600
	125	36	36	29.5	1.5	1.5	172 000	282 000	17 500	28 800	2 800	3 600
	130	37	37	29	2	1.5	186 000	289 000	19 000	29 400	2 600	3 600
	140	28.25	26	22	2.5	2	157 000	195 000	16 000	19 900	2 600	3 400
	140	28.25	26	20	2.5	2	147 000	190 000	15 000	19 400	2 400	3 400
	140	35.25	33	28	2.5	2	192 000	254 000	19 600	25 900	2 600	3 400
	140	46	46	35	2.5	2	256 000	385 000	26 200	39 000	2 600	3 400
	170	42.5	39	33	3	2.5	276 000	330 000	28 200	33 500	2 200	3 000
	170	42.5	39	27	3	2.5	235 000	283 000	24 000	28 900	2 000	2 800

Remarks The suffix CA represents medium-angle tapered roller bearings. Since they are designed for specific applications, please consult NSK when using bearings with suffix CA.

Bearing Numbers	ISO355 Dimension Series approx	Abutment and Fillet Dimensions (mm)						Cone r max	Cup r max	Eff. Load Centers (mm) a	Constant e	Axial Load Factors		Mass (kg) approx	
		d <sub>a</sub> min	d <sub>b</sub> max	D <sub>a</sub> max	D <sub>b</sub> min	S <sub>a</sub> min	S <sub>b</sub> min					Y <sub>1</sub>	Y <sub>0</sub>		
HR 32914 J	2BC	79	76	94	93	96	4	4	1	1	17.6	0.32	1.9	1.1	0.494
HR 32014 XJ	4CC	81	77	101	98	105	5	6	1.5	1.5	23.7	0.43	1.4	0.76	0.869
HR 33014 J	2CE	81	78	101	100	105	5	5.5	1.5	1.5	22.2	0.28	2.1	1.2	1.11
HR 33114 J	3DE	82	79	111	104	115	6	8	2	1.5	27.9	0.38	1.6	0.87	1.71
HR 30214 J	3EB	82	81	116	110	118	4	5	2	1.5	25.7	0.42	1.4	0.79	1.3
HR 32214 J	3EC	82	80	116	108	119	4	6	2	1.5	28.6	0.42	1.4	0.79	1.66
HR 33214 J	3EE	82	78	116	107	120	7	9	2	1.5	30.4	0.41	1.5	0.81	2.15
T 7 FC070	7FC	88	79	126	106	133	5	12	2.5	2.5	45.7	0.87	0.69	0.38	2.55
HR 30314 J	2GB	88	89	138	132	140	4	8	2.5	2	29.7	0.35	1.7	0.96	3.03
HR 30314 DJ	7GB	94	85	138	118	142	4	13	2.5	2	45.7	0.83	0.73	0.40	2.94
HR 31314 J	7GB	94	85	138	118	142	4	13	2.5	2	45.7	0.83	0.73	0.40	2.94
HR 32314 J	2GD	91	86	138	124	140	4	12	2.5	2	36.0	0.35	1.7	0.96	4.35
HR 32314 CJ	5GD	91	84	138	115	141	4	12	2.5	2	43.3	0.55	1.1	0.60	4.47
HR 32915 J	2BC	84	81	99	98	101	4	4	1	1	18.7	0.33	1.8	0.99	0.53
HR 32015 XJ	4CC	86	82	106	103	110	5	6	1.5	1.5	25.1	0.46	1.3	0.72	0.925
HR 33015 J	2CE	86	83	106	104	110	6	5.5	1.5	1.5	23.0	0.30	2.0	1.1	1.18
HR 33115 J	3DE	87	83	115	109	120	6	8	2	2	29.1	0.40	1.5	0.83	1.8
HR 30215 J	4DB	87	85	121	115	124	4	5	2	1.5	27.0	0.44	1.4	0.76	1.43
HR 32215 J	4DC	87	84	121	113	125	4	6	2	1.5	29.8	0.44	1.4	0.76	1.72
HR 33215 J	3EE	87	83	121	111	125	7	10	2	1.5	31.6	0.43	1.4	0.77	2.25
HR 30315 J	2GB	93	95	148	141	149	4	9	2.5	2	31.8	0.35	1.7	0.96	3.63
HR 30315 DJ	7GB	99	91	148	129	152	6	14	2.5	2	48.7	0.83	0.73	0.40	3.47
HR 31315 J	7GB	99	91	148	129	152	6	14	2.5	2	48.7	0.83	0.73	0.40	3.47
HR 32315 J	2GD	96	91	148	134	149	4	13	2.5	2	38.9	0.35	1.7	0.96	5.31
32315 CA	—	96	90	148	124	153	4	15	2.5	2	47.7	0.58	1.0	0.57	5.3
HR 32916 J	2BC	89	85	104	102	106	4	4	1	1	19.8	0.35	1.7	0.94	0.56
HR 32016 XJ	3CC	91	89	116	112	120	6	7	1.5	1.5	26.9	0.42	1.4	0.78	1.32
HR 33016 J	2CE	91	88	116	112	119	6	6.5	1.5	1.5	25.5	0.28	2.2	1.2	1.66
HR 33116 J	3DE	82	88	121	113	126	6	8	2	1.5	30.4	0.42	1.4	0.79	1.88
HR 30216 J	3EB	95	91	130	124	132	4	6	2	2	28.1	0.42	1.4	0.79	1.68
30216 CA	—	95	92	130	122	133	4	8	2	2	33.7	0.58	1.0	0.57	1.66
HR 32216 J	3EC	95	90	130	122	134	4	7	2	2	30.6	0.42	1.4	0.79	2.13
HR 33216 J	3EE	95	89	130	119	135	7	11	2	2	34.8	0.43	1.4	0.78	2.93
HR 30316 J	2GB	98	102	158	150	159	4	9.5	2.5	2	34.0	0.35	1.7	0.96	4.27
HR 30316 DJ	7GB	104	97	158	136	159	6	15.5	2.5	2	51.8	0.83	0.73	0.40	4.07
HR 31316 J	7GB	104	97	158	136	159	6	15.5	2.5	2	51.8	0.83	0.73	0.40	4.07
HR 32316 J	2GD	101	98	158	143	159	4	13.5	2.5	2	41.3	0.35	1.7	0.96	6.35
HR 32316 CJ	5GD	101	95	158	132	160	4	13.5	2.5	2	49.2	0.55	1.1	0.60	6.59

Bore Diameter 85~100 mm

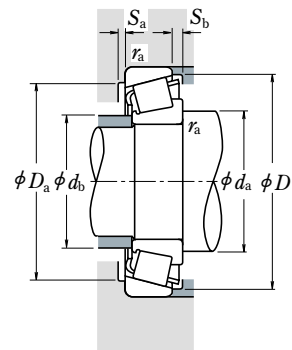
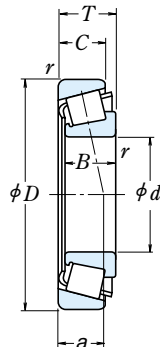

Dynamic Equivalent Load

$$P = XF_r + YF_a$$

$F_a/F_r \leq e$		$F_a/F_r > e$	
X	Y	X	Y
1	0	0.4	$Y_1$

Static Equivalent Load

$$P_0 = 0.5F_r + Y_0F_a$$

When  $F_r > 0.5F_r + Y_0F_a$ , use  $P_0 = F_r$

The values of  $e$ ,  $Y_1$ , and  $Y_0$  are given in the table below.

Boundary Dimensions (mm)					Basic Load Ratings				Limiting Speeds (rpm)			
$d$	$D$	$T$	$B$	$C$	Cone $r_{min}$	Cup $r_{max}$	(N)		(kgf)			
							$C_r$	$C_{0r}$	$C_r$	$C_{0r}$	Grease	Oil
85	120	23	23	18	1.5	1.5	93 500	157 000	9 550	16 000	2 800	3 800
130	29	29	22	1.5	1.5	143 000	231 000	14 600	23 600	2 600	3 600	
130	36	36	29.5	1.5	1.5	180 000	305 000	18 400	31 000	2 600	3 600	
140	41	41	32	2.5	2	230 000	365 000	23 500	37 000	2 400	3 400	
150	30.5	28	24	2.5	2	184 000	233 000	18 700	23 800	2 400	3 200	
150	30.5	28	22	2.5	2	171 000	226 000	17 500	23 000	2 200	3 200	
150	38.5	36	30	2.5	2	210 000	277 000	21 400	28 200	2 200	3 200	
150	49	49	37	2.5	2	281 000	415 000	28 700	42 500	2 400	3 200	
180	44.5	41	34	4	3	310 000	375 000	31 500	38 000	2 000	2 800	
180	44.5	41	28	4	3	261 000	315 000	26 600	32 000	1 900	2 600	
180	44.5	41	28	4	3	261 000	315 000	26 600	32 000	1 900	2 600	
180	63.5	60	49	4	3	410 000	535 000	42 000	54 500	2 000	2 800	
90	125	23	23	18	1.5	1.5	97 000	167 000	9 850	17 000	2 600	3 600
140	32	32	24	2	1.5	170 000	273 000	17 300	27 800	2 400	3 200	
140	39	39	32.5	2	1.5	220 000	360 000	22 400	37 000	2 400	3 200	
150	45	45	35	2.5	2	259 000	405 000	26 500	41 500	2 400	3 200	
160	32.5	30	26	2.5	2	201 000	256 000	20 500	26 100	2 200	3 000	
160	42.5	40	34	2.5	2	256 000	350 000	26 100	35 500	2 200	3 000	
190	46.5	43	36	4	3	345 000	425 000	35 500	43 000	1 900	2 600	
190	46.5	43	30	4	3	264 000	315 000	26 900	32 000	1 800	2 400	
190	46.5	43	30	4	3	264 000	315 000	26 900	32 000	1 800	2 400	
190	67.5	64	53	4	3	450 000	590 000	46 000	60 500	2 000	2 600	
95	130	23	23	18	1.5	1.5	98 000	172 000	10 000	17 500	2 400	3 400
145	32	32	24	2	1.5	173 000	283 000	17 600	28 900	2 400	3 200	
145	39	39	32.5	2	1.5	231 000	390 000	23 500	39 500	2 400	3 200	
160	46	46	38	3	3	283 000	445 000	28 800	45 500	2 200	3 000	
170	34.5	32	27	3	2.5	223 000	286 000	22 800	29 200	2 200	2 800	
170	45.5	43	37	3	2.5	289 000	400 000	29 500	40 500	2 200	2 800	
200	49.5	45	38	4	3	370 000	455 000	38 000	46 500	1 900	2 600	
200	49.5	45	36	4	3	350 000	430 000	35 500	44 000	1 800	2 400	
200	49.5	45	32	4	3	310 000	375 000	31 500	38 500	1 700	2 400	
200	49.5	45	32	4	3	310 000	375 000	31 500	38 500	1 700	2 400	
200	71.5	67	55	4	3	525 000	710 000	53 500	72 500	1 900	2 600	
100	140	25	25	20	1.5	1.5	117 000	205 000	12 000	20 900	2 200	3 200
145	24	22.5	17.5	3	3	113 000	163 000	11 500	16 600	2 200	3 000	
150	32	32	24	2	1.5	176 000	294 000	17 900	30 000	2 200	3 000	
150	39	39	32.5	2	1.5	235 000	405 000	24 000	41 500	2 200	3 000	
165	52	52	40	2.5	2	315 000	515 000	32 500	52 500	2 000	2 800	
180	37	34	29	3	2.5	255 000	330 000	26 000	34 000	2 000	2 600	
180	49	46	39	3	2.5	325 000	450 000	33 000	46 000	2 000	2 600	
180	63	63	48	3	2.5	410 000	635 000	42 000	65 000	2 000	2 600	
215	51.5	47	39	4	3	425 000	525 000	43 000	53 500	1 700	2 400	
215	56.5	51	35	4	3	385 000	505 000	39 000	51 500	1 500	2 200	
215	77.5	73	60	4	3	565 000	755 000	57 500	77 000	1 700	2 400	

Remarks The suffix CA represents medium-angle tapered roller bearings. Since they are designed for specific applications, please consult NSK when using bearings with suffix CA.

Bearing Numbers	ISO355 Dimension Series approx	Abutment and Fillet Dimensions (mm)						Cone $r_{max}$	Cup $r_{min}$	Eff. Load Centers (mm) $a$	Constant $e$	Axial Load Factors		Mass (kg) approx	
		$d_a$ min	$d_b$ max	$D_a$ max	$D_b$ min	$S_a$ min	$S_b$ min					$Y_1$	$Y_0$		
HR 32917 J	2BC	96	92	111	111	115	5	5	1.5	1.5	20.9	0.33	1.8	1.0	0.8
HR 32017 XJ	4CC	96	94	121	116	125	6	7	1.5	1.5	28.2	0.44	1.4	0.75	1.38
HR 33017 J	2CE	96	94	121	117	125	6	6.5	1.5	1.5	26.5	0.29	2.1	1.1	1.75
HR 33117 J	3DE	100	94	130	122	135	7	9	2	2	32.7	0.41	1.5	0.81	2.51
HR 30217 J	3EB	100	97	140	133	141	5	6.5	2	2	30.3	0.42	1.4	0.79	2.12
30217 CA	—	100	98	140	131	142	5	8.5	2	2	36.2	0.58	1.0	0.57	2.07
HR 32217 J	3EC	100	96	140	131	142	5	8.5	2	2	33.8	0.42	1.4	0.79	2.64
HR 33217 J	3EE	100	95	140	129	144	7	12	2	2	37.3	0.42	1.4	0.79	3.57
HR 30317 J	2GB	106	108	166	157	167	5	10.5	3	2.5	35.7	0.35	1.7	0.96	5.08
HR 30317 DJ	7GB	113	103	166	144	169	6	16.5	3	2.5	55.3	0.83	0.73	0.40	4.88
HR 31317 J	7GB	113	103	166	144	169	6	16.5	3	2.5	55.3	0.83	0.73	0.40	4.88
HR 32317 J	2GD	110	104	166	151	167	5	14.5	3	2.5	43.5	0.35	1.7	0.96	7.31
HR 32918 J	2BC	101	97	116	116	120	5	5	1.5	1.5	22.0	0.34	1.8	0.96	0.838
HR 32018 XJ	3CC	102	99	131	124	134	6	8	2	1.5	29.7	0.42	1.4	0.78	1.78
HR 33018 J	2CE	102	99	131	129	135	7	6.5	2	1.5	27.9	0.27	2.2	1.2	2.21
HR 33118 J	3DE	105	100	140	132	144	7	10	2	2	35.2	0.40	1.5	0.83	3.14
HR 30218 J	3FB	105	103	150	141	150	5	6.5	2	2	31.7	0.42	1.4	0.79	2.6
HR 32218 J	3FC	105	102	150	139	152	5	8.5	2	2	36.1	0.42	1.4	0.79	3.41
HR 30318 J	2GB	111	114	176	176	176	5	10.5	3	2.5	37.3	0.35	1.7	0.96	5.91
HR 30318 DJ	7GB	118	110	176	152	179	6	16.5	3	2.5	58.6	0.83	0.73	0.40	5.52
HR 31318 J	7GB	118	110	176	152	179	6	16.5	3	2.5	58.6	0.83	0.73	0.40	5.52
HR 32318 J	2GD	115	109	176	158	177	5	14.5	3	2.5	46.5	0.35	1.7	0.96	8.6
HR 32919 J	2BC	106	102	121	121	125	5	5	1.5	1.5	23.2	0.36	1.7	0.92	0.877
HR 32019 XJ	4CC	107	104	136	131	140	6	8	2	1.5	31.2	0.44	1.4	0.75	1.88
HR 33019 J	2CE	107	103	136	133	139	7	6.5	2	1.5	28.6	0.28	2.2	1.2	2.3
T 2 ED095	2ED	113	108	146	141	152	6	8	2.5	2.5	34.5	0.34	1.8	0.97	3.74
HR 30219 J	3FB	113	110	158	150	159	5	7.5	2.5	2	33.7	0.42	1.4	0.79	3.13
HR 32219 J	3FC	113	108	158	147	161	5	8.5	2.5	2	39.3	0.42	1.4	0.79	4.22
HR 30319 J	2GB	116	119	186	172	184	5	11.5	3	2.5	38.6	0.35	1.7	0.96	6.92
30319 CA	—	116	119	186	168	188	5	13.5	3	2.5	48.6	0.54	1.1	0.61	6.71
HR 30319 DJ	7GB	123	115	186	158	187	6	17.5	3	2.5	61.9	0.83	0.73	0.40	6.64
HR 31319 J	7GB	123	115	186	158	187	6	17.5	3	2.5	61.9	0.83	0.73	0.40	6.64
HR 32319 J	2GD	120	115	186	167	186	5	16.5	3	2.5	48.6	0.35	1.7	0.96	10.4
HR 32920 J	2CC	111	109	132	132	134	5	5	1.5	1.5	24.2	0.33	1.8	1.0	1.18
T 4 CB100	4CB	118	108	135	135	142	6	6.5	2.5	2.5	30.1	0.47	1.3	0.70	1.18
HR 32020 XJ	4CC	112	109	141	136	144	6	8	2	1.5	32.5	0.46	1.3	0.72	1.95
HR 33020 J	2CE	112	107	141	137	143	7	6.5	2	1.5	29.3	0.29	2.1	1.2	2.38
HR 33120 J	3EE	115	110	155	144	159	8	12	2	2	40.5	0.41	1.5	0.81	4.32
HR 30220 J	3FB	118	116	168	158	168	5	8	2.5	2	36.1	0.42	1.4	0.79	3.78
HR 32220 J	3FC	118	115	168	155	171	5	10	2.5	2	41.5	0.42	1.4	0.79	5.05
HR 33220 J	3FE	118	113	168	152	172	10	15	2.5	2	45.9	0.40	1.5	0.82	6.76
HR 30320 J	2GB	121	128	201	185	197	5	12.5	3	2.5	41.1	0.35	1.7	0.96	8.41
HR 31320 J	7GB	136	125	201	169	202	7	21.5	3	2.5	67.7	0.83</			

Bore Diameter 105~130 mm

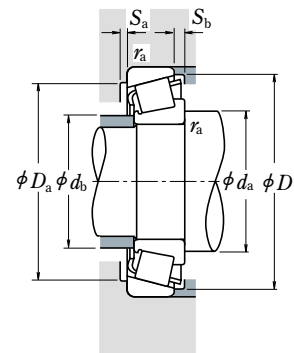
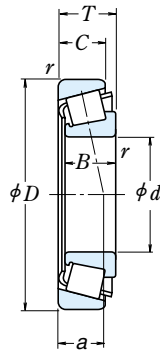

Dynamic Equivalent Load

$$P = X F_r + Y F_a$$

$F_a/F_r \leq e$		$F_a/F_r > e$	
X	Y	X	Y
1	0	0.4	$Y_1$

Static Equivalent Load

$$P_0 = 0.5 F_r + Y_0 F_a$$

When  $F_r > 0.5 F_r + Y_0 F_a$ , use  $P_0 = F_r$

The values of  $e$ ,  $Y_1$ , and  $Y_0$  are given in the table below.

Boundary Dimensions (mm)							Basic Load Ratings				Limiting Speeds (rpm)		
$d$	$D$	$T$	$B$	$C$	Cone $r$	Cup $r$	(N)		(kgf)		Grease	Oil	
					min		$C_r$	$C_{0r}$	$C_r$	$C_{0r}$			
105	145	25	25	20	1.5	1.5	119 000	212 000	12 100	21 600	2 200	3 000	
	160	35	35	26	2.5	2	204 000	340 000	20 800	34 500	2 000	2 800	
	160	43	43	34	2.5	2	256 000	435 000	26 100	44 000	2 000	2 800	
	190	39	36	30	3	2.5	280 000	365 000	28 500	37 500	1 900	2 600	
	190	53	50	43	3	2.5	360 000	510 000	37 000	52 000	1 900	2 600	
	225	53.5	49	41	4	3	455 000	565 000	46 500	57 500	1 600	2 200	
	225	58	53	36	4	3	415 000	540 000	42 000	55 000	1 500	2 000	
	225	81.5	77	63	4	3	670 000	925 000	68 000	94 500	1 700	2 200	
	110	150	25	25	20	1.5	1.5	123 000	224 000	12 500	22 800	2 200	2 800
		170	38	38	29	2.5	2	236 000	390 000	24 000	40 000	2 000	2 600
170		47	47	37	2.5	2	294 000	515 000	30 000	52 500	2 000	2 600	
180		56	56	43	2.5	2	365 000	610 000	37 500	62 000	1 900	2 600	
200		41	38	32	3	2.5	315 000	420 000	32 000	43 000	1 800	2 400	
200		56	53	46	3	2.5	400 000	565 000	40 500	57 500	1 800	2 400	
240		54.5	50	42	4	3	485 000	595 000	49 500	60 500	1 500	2 000	
240		63	57	38	4	3	470 000	605 000	48 000	62 000	1 400	1 900	
240		84.5	80	65	4	3	675 000	910 000	68 500	93 000	1 500	2 000	
120		165	29	29	23	1.5	1.5	161 000	291 000	16 400	29 700	1 900	2 600
	170	27	25	19.5	3	3	153 000	243 000	51 600	24 800	1 800	2 600	
	180	38	38	29	2.5	2	242 000	405 000	24 600	41 000	1 800	2 400	
	180	48	48	38	2.5	2	300 000	540 000	30 500	55 000	1 800	2 600	
	200	62	62	48	2.5	2	460 000	755 000	46 500	77 000	1 700	2 400	
	215	43.5	40	34	3	2.5	335 000	450 000	34 000	46 000	1 600	2 200	
	215	61.5	58	50	3	2.5	440 000	635 000	44 500	65 000	1 600	2 200	
	260	59.5	55	46	4	3	535 000	655 000	54 500	67 000	1 400	1 900	
	260	68	62	42	4	3	560 000	730 000	57 000	74 500	1 300	1 800	
	260	90.5	86	69	4	3	770 000	1 060 000	78 500	108 000	1 400	1 900	
130	180	32	30	26	2	1.5	167 000	281 000	17 000	28 600	1 800	2 400	
	180	32	32	25	2	1.5	200 000	365 000	20 400	37 500	1 800	2 400	
	185	29	27	21	3	3	183 000	296 000	18 600	30 000	1 700	2 400	
	200	45	45	34	2.5	2	320 000	535 000	32 500	54 500	1 600	2 200	
	200	55	55	43	2.5	2	395 000	715 000	40 500	73 000	1 700	2 200	
	230	43.75	40	34	4	3	375 000	505 000	38 000	51 500	1 500	2 000	
	230	67.75	64	54	4	3	530 000	790 000	54 000	80 500	1 500	2 000	
	280	63.75	58	49	5	4	545 000	675 000	56 000	68 500	1 300	1 800	
	280	63.75	58	49	5	4	650 000	820 000	66 000	83 500	1 300	1 800	
	280	72	66	44	5	4	625 000	820 000	63 500	83 500	1 200	1 700	
280	98.75	93	78	5	4	830 000	1 150 000	84 500	117 000	1 300	1 800		

Bearing Numbers	ISO355 Dimension Series approx	Abutment and Fillet Dimensions (mm)								Eff. Load Centers (mm) $a$	Constant $e$	Axial Load Factors		Mass (kg) approx	
		$d_a$ min	$d_b$ max	$D_a$ max	$D_b$ min	$S_a$ min	$S_b$ min	Cone $r_a$ max	Cup $r_a$ max			$Y_1$	$Y_0$		
<b>HR 32921 J</b>	2CC	116	114	137	137	140	5	5	1.5	1.5	25.3	0.34	1.8	0.96	1.23
<b>HR 32021 XJ</b>	4DC	120	115	150	144	154	6	9	2	2	34.3	0.44	1.4	0.74	2.48
<b>HR 33021 J</b>	2DE	120	115	150	146	153	7	9	2	2	30.9	0.28	2.1	1.2	3.03
<b>HR 30221 J</b>	3FB	123	123	178	166	177	6	9	2.5	2	38.1	0.42	1.4	0.79	4.51
<b>HR 32221 J</b>	3FC	123	120	178	162	180	5	10	2.5	2	44.8	0.42	1.4	0.79	6.25
<b>HR 30321 J</b>	2GB	126	133	211	195	206	6	12.5	3	2.5	43.2	0.35	1.7	0.96	9.52
<b>HR 31321 J</b>	7GB	141	130	211	177	211	7	22	3	2.5	70.2	0.83	0.73	0.40	10
<b>HR 32321 J</b>	2GD	130	129	211	186	209	6	18.5	3	2.5	55.2	0.35	1.7	0.96	14.9
<b>HR 32922 J</b>	2CC	121	119	142	142	145	5	5	1.5	1.5	26.5	0.36	1.7	0.93	1.29
<b>HR 32022 XJ</b>	4DC	125	121	160	153	163	7	9	2	2	35.9	0.43	1.4	0.77	3.09
<b>HR 33022 J</b>	2DE	125	121	160	153	161	7	10	2	2	33.7	0.29	2.1	1.2	3.84
<b>HR 33122 J</b>	3EE	125	121	170	156	174	9	13	2	2	44.1	0.42	1.4	0.79	5.54
<b>HR 30222 J</b>	3FB	128	129	188	175	187	6	9	2.5	2	40.1	0.42	1.4	0.79	5.28
<b>HR 32222 J</b>	3FC	128	127	188	171	190	5	10	2.5	2	47.2	0.42	1.4	0.79	7.35
<b>HR 30322 J</b>	2GB	131	143	226	208	220	6	12.5	3	2.5	45.1	0.35	1.7	0.96	11
<b>HR 31322 J</b>	7GB	146	136	226	191	224	7	25	3	2.5	74.7	0.83	0.73	0.40	12.3
<b>HR 32322 J</b>	2GD	135	139	226	201	222	6	19.5	3	2.5	58.5	0.35	1.7	0.96	17.1
<b>HR 32924 J</b>	2CC	131	129	156	155	160	6	6	1.5	1.5	29.2	0.35	1.7	0.95	1.8
<b>T 4 CB120</b>	4CB	138	129	158	158	164	7	7.5	2.5	2.5	35.0	0.47	1.3	0.70	1.78
<b>HR 32024 XJ</b>	4DC	135	131	170	162	173	7	9	2	2	39.7	0.46	1.3	0.72	3.27
<b>HR 33024 J</b>	2DE	135	130	168	161	171	6	10	2	2	36.0	0.31	2.0	1.1	4.2
<b>HR 33124 J</b>	3FE	135	133	190	173	192	9	14	2	2	47.9	0.40	1.5	0.83	7.67
<b>HR 30224 J</b>	4FB	138	141	203	190	201	6	9.5	2.5	2	44.4	0.44	1.4	0.76	6.28
<b>HR 32224 J</b>	4FD	138	137	203	181	204	6	11.5	2.5	2	52.0	0.44	1.4	0.76	9.0
<b>HR 30324 J</b>	2GB	141	154	246	223	237	6	13.5	3	2.5	50.0	0.35	1.7	0.96	13.9
<b>HR 31324 J</b>	7GB	156	148	246	206	244	9	26	3	2.5	81.6	0.83	0.73	0.40	15.6
<b>HR 32324 J</b>	2GD	145	149	246	216	239	6	21.5	3	2.5	62.4	0.35	1.7	0.96	21.8
<b>32926</b>	—	142	141	171	168	175	6	6	2	1.5	34.7	0.36	1.7	0.92	2.25
<b>HR 32926 J</b>	2CC	142	140	170	168	173	6	7	2	1.5	31.4	0.34	1.8	0.97	2.46
<b>T 4 CB130</b>	4CB	148	141	171	171	179	8	8	2.5	2.5	37.5	0.47	1.3	0.70	2.32
<b>HR 32026 XJ</b>	4EC	145	144	190	179	192	8	11	2	2	43.9	0.43	1.4	0.76	5.06
<b>HR 33026 J</b>	2EE	145	144	188	179	192	8	12	2	2	42.4	0.34	1.8	0.97	6.25
<b>HR 30226 J</b>	4FB	151	151	216	205	217	7	9.5	3	2.5	45.8	0.44	1.4	0.76	7.25
<b>HR 32226 J</b>	4FD	151	147	216	196	219	7	13.5	3	2.5	56.9	0.44	1.4	0.76	11.3
<b>30326</b>	—	157	168	262	239	255	8	14.5	4	3	53.9	0.36	1.7	0.92	16.6
<b>HR 30326 J</b>	2GB	157	166	262	241	255	8	14.5	4	3	52.7	0.35	1.7	0.96	17.2
<b>HR 31326 J</b>	7GB	174	159	262	220	261	9	28	4	3	87.1	0.83	0.73	0.40	18.8
<b>32326</b>	—	162	165	262	233	263	8	20.5	4	3	69.2	0.36	1.7	0.92	26.6

Bore Diameter 140~170 mm

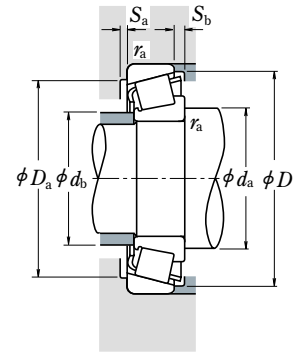
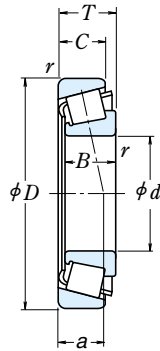

Dynamic Equivalent Load

$$P = X F_r + Y F_a$$

$F_a/F_r \leq e$		$F_a/F_r > e$	
X	Y	X	Y
1	0	0.4	$Y_1$

Static Equivalent Load

$$P_0 = 0.5 F_r + Y_0 F_a$$

When  $F_r > 0.5 F_r + Y_0 F_a$ , use  $P_0 = F_r$

The values of  $e$ ,  $Y_1$ , and  $Y_0$  are given in the table below.

d	Boundary Dimensions (mm)				Cone Cup		Basic Load Ratings				Limiting Speeds (rpm)		
	D	T	B	C	r <sub>min</sub>	r <sub>max</sub>	C <sub>r</sub>	C <sub>0r</sub>	C <sub>r</sub>	C <sub>0r</sub>	Grease	Oil	
140	190	32	32	25	2	1.5	206 000	390 000	21 000	39 500	1 700	2 200	
	210	45	45	34	2.5	2	325 000	555 000	33 000	57 000	1 600	2 200	
	210	56	56	44	2.5	2	410 000	770 000	42 000	78 500	1 600	2 200	
	250	45.75	42	36	4	3	390 000	515 000	40 000	52 500	1 400	1 900	
	250	71.75	68	58	4	3	610 000	915 000	62 000	93 500	1 400	1 900	
	300	67.75	62	53	5	4	740 000	945 000	75 500	96 500	1 200	1 700	
	300	77	70	47	5	4	695 000	955 000	71 000	97 500	1 100	1 500	
	300	107.75	102	85	5	4	985 000	1 440 000	101 000	147 000	1 200	1 600	
	150	210	38	36	31	2.5	2	247 000	440 000	25 200	45 000	1 500	2 000
		210	38	38	30	2.5	2	281 000	520 000	28 600	53 000	1 500	2 000
225		48	48	36	3	2.5	375 000	650 000	38 000	66 500	1 400	2 000	
225		59	59	46	3	2.5	435 000	805 000	44 000	82 000	1 400	2 000	
270		49	45	38	4	3	485 000	665 000	49 000	67 500	1 300	1 800	
270		77	73	60	4	3	705 000	1 080 000	71 500	110 000	1 300	1 800	
320		72	65	55	5	4	690 000	860 000	70 000	87 500	1 100	1 500	
320		72	65	55	5	4	825 000	1 060 000	84 500	108 000	1 100	1 600	
320		82	75	50	5	4	790 000	1 100 000	80 500	112 000	1 000	1 400	
320		114	108	90	5	4	1 120 000	1 700 000	114 000	174 000	1 100	1 500	
160	220	38	38	30	2.5	2	296 000	570 000	30 000	58 000	1 400	1 900	
	240	51	51	38	3	2.5	425 000	750 000	43 500	76 500	1 300	1 800	
	290	52	48	40	4	3	530 000	730 000	54 000	74 500	1 200	1 600	
	290	84	80	67	4	3	795 000	1 120 000	81 000	125 000	1 200	1 600	
	340	75	68	58	5	4	765 000	960 000	78 000	98 000	1 000	1 400	
	340	75	68	58	5	4	870 000	1 110 000	89 000	113 000	1 100	1 400	
	340	75	68	48	5	4	675 000	875 000	69 000	89 000	950	1 300	
	340	121	114	95	5	4	1 210 000	1 770 000	123 000	181 000	1 000	1 400	
	170	230	38	36	31	2.5	2.5	258 000	485 000	26 300	49 500	1 300	1 800
		230	38	38	30	2.5	2	294 000	560 000	30 000	57 000	1 400	1 800
260		57	57	43	3	2.5	505 000	890 000	51 500	90 500	1 200	1 700	
310		57	52	43	5	4	630 000	885 000	64 000	90 000	1 100	1 500	
310		91	86	71	5	4	930 000	1 450 000	94 500	148 000	1 100	1 500	
360		80	72	62	5	4	845 000	1 080 000	86 000	110 000	950	1 300	
360		80	72	62	5	4	960 000	1 230 000	98 000	125 000	1 000	1 300	
360		80	72	50	5	4	760 000	1 040 000	77 500	106 000	900	1 200	
360		127	120	100	5	4	1 370 000	2 050 000	140 000	209 000	1 000	1 300	

Bearing Numbers	ISO355 Dimension Series approx	Abutment and Fillet Dimensions (mm)						Cone Cup	Eff. Load Centers (mm) a	Constant e	Axial Load Factors		Mass (kg) approx		
		d <sub>a</sub> min	d <sub>b</sub> max	D <sub>a</sub> max	D <sub>b</sub> min	S <sub>a</sub> min	S <sub>b</sub> min				Y <sub>1</sub>	Y <sub>0</sub>			
HR 32928 J HR 32028 XJ HR 33028 J	2CC	152	150	180	178	184	6	7	2	1.5	33.6	0.36	1.7	0.92	2.64
	4DC	155	152	200	189	202	8	11	2	2	46.6	0.46	1.3	0.72	5.32
	2DE	155	153	198	189	202	7	12	2	2	45.5	0.36	1.7	0.92	6.74
HR 30228 J HR 32228 J HR 30328 J	4FB	161	164	236	221	234	7	9.5	3	2.5	48.9	0.44	1.4	0.76	8.74
	4FD	161	159	236	213	238	9	13.5	3	2.5	60.5	0.44	1.4	0.76	14.3
	2GB	167	177	282	256	273	9	14.5	4	3	55.7	0.35	1.7	0.96	21.1
HR 31328 J 32328	7GB	184	174	282	236	280	9	30	4	3	92.8	0.83	0.73	0.40	28.5
	—	172	177	282	246	281	9	22.5	4	3	76.4	0.37	1.6	0.88	33.9
32930 HR 32930 J HR 32030 XJ	—	165	162	200	195	201	7	7	2	2	36.7	0.33	1.8	1.0	3.8
	2DC	165	163	198	196	202	7	8	2	2	36.5	0.33	1.8	1.0	4.05
	4EC	168	164	213	202	216	8	12	2.5	2	49.8	0.46	1.3	0.72	6.6
HR 33030 J HR 30230 J HR 32230 J	2EE	168	165	213	203	217	8	13	2.5	2	48.7	0.36	1.7	0.90	8.07
	2GB	171	175	256	236	250	7	11	3	2.5	51.3	0.44	1.4	0.76	11.2
	4GD	171	171	256	228	254	8	17	3	2.5	64.7	0.44	1.4	0.76	17.8
30330 HR 30330 J HR 31330 J 32330	—	177	193	302	275	292	8	17	4	3	61.4	0.36	1.7	0.92	24.2
	2GB	177	190	302	276	292	8	17	4	3	60.0	0.35	1.7	0.96	25
	7GB	194	187	302	253	300	9	32	4	3	99.3	0.83	0.73	0.40	28.5
32330	—	182	191	302	262	297	8	24	4	3	81.5	0.37	1.6	0.88	41.4
HR 32932 J HR 32032 XJ HR 30232 J	2DC	175	173	208	206	212	7	8	2	2	38.7	0.35	1.7	0.95	4.32
	4EC	178	175	228	216	231	8	13	2.5	2	53.0	0.46	1.3	0.72	7.93
	4GB	181	189	276	253	269	8	12	3	2.5	55.0	0.44	1.4	0.76	13.7
HR 32232 J 30332 HR 30232 J	4GD	181	184	276	243	274	10	17	3	2.5	70.5	0.44	1.4	0.76	22.7
	—	187	205	322	293	311	10	17	4	3	64.6	0.36	1.7	0.92	28.4
	2GB	187	201	322	293	310	10	17	4	3	62.9	0.35	1.7	0.96	29.2
30332 D 32332	—	196	198	322	270	313	9	27	4	3	99.3	0.81	0.74	0.41	27.5
	—	192	202	322	281	319	10	26	4	3	87.1	0.37	1.6	0.88	48.3
32934 HR 32934 J HR 32034 XJ	—	185	183	220	216	223	7	7	2	2	41.6	0.36	1.7	0.90	4.3
	3DC	185	180	218	215	222	7	8	2	2	41.7	0.38	1.6	0.86	4.44
	4EC	188	187	248	232	249	10	14	2.5	2	56.6	0.44	1.4	0.74	10.6
HR 30234 J HR 32234 J 30334	4GB	197	202	292	273	288	8	14	4	3	59.4	0.44	1.4	0.76	17.1
	4GD	197	197	292	262	294	10	20	4	3	76.4	0.44	1.4	0.76	28
	—	197	221	342	312	332	10	18	4	3	70.1	0.37	1.6	0.90	33.5
HR 30334 J 30334 D 32334	2GB	197	214	342	310	329	10	18	4	3	67.3	0.35	1.7	0.96	34.5
	—	206	215	342	288	332	10	30	4	3	107.3	0.81	0.74	0.41	33.4
	—	202	213	342	297	337	10	27	4	3	91.3	0.37	1.6	0.88	57

Bore Diameter 180~240 mm

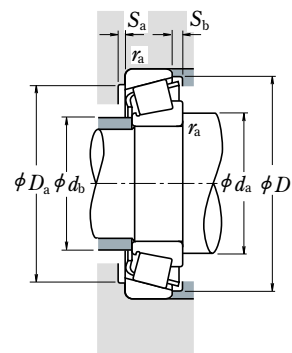
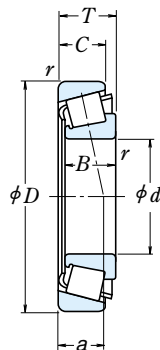

Dynamic Equivalent Load

$$P = XF_r + YF_a$$

$F_a/F_r \leq e$		$F_a/F_r > e$	
X	Y	X	Y
1	0	0.4	$Y_1$

Static Equivalent Load

$$P_0 = 0.5F_r + Y_0F_a$$

When  $F_r > 0.5F_r + Y_0F_a$ , use  $P_0 = F_r$

The values of  $e$ ,  $Y_1$ , and  $Y_0$  are given in the table below.

Boundary Dimensions (mm)					Basic Load Ratings				Limiting Speeds (rpm)			
$d$	$D$	$T$	$B$	$C$	Cone Cup		(N)		{kgf}			
					$r$	$r_{min}$	$C_r$	$C_{Or}$	$C_r$	$C_{Or}$	Grease	Oil
180	250	45	45	34	2.5	2	350 000	685 000	36 000	69 500	1 300	1 700
	280	64	64	48	3	2.5	640 000	1 130 000	65 000	115 000	1 200	1 600
	320	57	52	43	5	4	650 000	930 000	66 000	95 000	1 100	1 400
	320	91	86	71	5	4	960 000	1 540 000	98 000	157 000	1 100	1 400
	380	83	75	64	5	4	935 000	1 230 000	95 500	126 000	900	1 300
	380	83	75	53	5	4	820 000	1 120 000	83 500	114 000	850	1 200
	380	134	126	106	5	4	1 520 000	2 290 000	155 000	234 000	950	1 300
	190	260	45	45	34	2.5	2	365 000	715 000	37 000	73 000	1 200
290		64	64	48	3	2.5	650 000	1 170 000	66 000	119 000	1 100	1 500
340		60	55	46	5	4	760 000	1 080 000	77 500	111 000	1 000	1 300
340		97	92	75	5	4	1 110 000	1 770 000	113 000	181 000	1 000	1 400
400		86	78	65	6	5	1 010 000	1 340 000	103 000	136 000	850	1 200
400		140	132	109	6	5	1 660 000	2 580 000	169 000	263 000	850	1 200
200	280	51	48	41	3	2.5	410 000	780 000	42 000	80 000	1 100	1 500
	280	51	51	39	3	2.5	480 000	935 000	48 500	95 000	1 100	1 500
	310	70	70	53	3	2.5	760 000	1 370 000	77 500	139 000	1 000	1 400
	360	64	58	48	5	4	825 000	1 180 000	84 000	121 000	950	1 300
	360	104	98	82	5	4	1 210 000	1 920 000	123 000	196 000	950	1 300
	420	89	80	67	6	5	1 030 000	1 390 000	105 000	142 000	850	1 200
220	420	89	80	56	6	5	965 000	1 330 000	98 500	136 000	750	1 000
	420	146	138	115	6	5	1 820 000	2 870 000	185 000	292 000	800	1 100
	300	51	51	39	3	2.5	490 000	990 000	50 000	101 000	1 000	1 400
	340	76	76	57	4	3	885 000	1 610 000	90 500	164 000	950	1 300
	400	72	65	54	5	4	810 000	1 150 000	82 500	117 000	850	1 100
	400	114	108	90	5	4	1 340 000	2 210 000	137 000	225 000	850	1 100
240	460	97	88	73	6	5	1 430 000	1 990 000	146 000	203 000	750	1 000
	460	154	145	122	6	5	2 020 000	3 200 000	206 000	325 000	750	1 000
	320	51	51	39	3	2.5	500 000	1 040 000	51 000	107 000	950	1 300
	360	76	76	57	4	3	920 000	1 730 000	94 000	177 000	850	1 200
	440	79	72	60	5	4	990 000	1 400 000	101 000	142 000	750	1 000
	440	127	120	100	5	4	1 630 000	2 730 000	166 000	278 000	750	1 000
500	105	95	80	6	5	1 660 000	2 340 000	169 000	238 000	670	950	
500	165	155	132	6	5	2 520 000	4 100 000	257 000	415 000	670	900	

Bearing Numbers	ISO355 Dimension Series approx	Abutment and Fillet Dimensions (mm)						Cone Cup	Eff. Load Centers (mm) $a$	Constant $e$	Axial Load Factors		Mass (kg) approx		
		$d_a$ min	$d_b$ max	$D_a$ max	$D_b$ min	$S_a$ min	$S_b$ min				$Y_1$	$Y_0$			
HR 32936 J HR 32036 XJ HR 30236 J	4DC	195	192	240	227	241	8	11	2	2	53.9	0.48	1.3	0.69	6.56
	3FD	198	199	268	248	267	10	16	2.5	2	60.4	0.42	1.4	0.78	14.3
	4GB	207	210	302	281	297	9	14	4	3	61.8	0.45	1.3	0.73	17.8
HR 32236 J 30336 30336 D 32336	4GD	207	205	302	270	303	10	20	4	3	78.8	0.45	1.3	0.73	29.8
	—	207	233	362	324	345	10	19	4	3	72.4	0.36	1.7	0.92	39.3
	—	216	229	362	304	352	10	30	4	3	113.1	0.81	0.74	0.41	38.5
	—	212	225	362	310	353	10	28	4	3	96.6	0.37	1.6	0.88	66.8
HR 32938 J HR 32038 XJ HR 30238 J	4DC	205	201	250	237	251	8	11	2	2	55.3	0.48	1.3	0.69	6.83
	4FD	208	209	278	258	279	10	16	2.5	2	63.3	0.44	1.4	0.75	14.9
	4GB	217	223	322	302	318	9	14	4	3	64.4	0.44	1.4	0.76	21.4
HR 32238 J 30338 32338	4GD	217	216	322	290	323	10	22	4	3	80.5	0.44	1.4	0.76	35.2
	—	223	248	378	346	366	11	21	5	4	76.1	0.36	1.7	0.92	46
	—	229	243	378	332	375	11	31	5	4	102.7	0.37	1.6	0.88	78.9
32940 HR 32940 J HR 32040 XJ	—	218	217	268	256	269	9	10	2.5	2	53.4	0.37	1.6	0.88	9.26
	3EC	218	216	268	258	271	9	12	2.5	2	54.2	0.39	1.5	0.84	9.65
	4FD	218	221	298	277	297	11	17	2.5	2	67.4	0.43	1.4	0.77	18.9
HR 30240 J HR 32240 J 30340	4GB	227	236	342	318	336	10	16	4	3	68.7	0.44	1.4	0.76	25.1
	3GD	227	230	342	305	340	11	22	4	3	85.1	0.41	1.5	0.81	42.6
	—	233	253	398	346	368	11	22	5	4	81.4	0.37	1.6	0.88	52.3
30340 D 32340	—	244	253	398	336	385	11	33	5	4	122.8	0.81	0.74	0.41	49.6
	—	239	253	398	346	392	11	31	5	4	106.7	0.37	1.6	0.88	90.9
HR 32944 J HR 32044 XJ 30244	3EC	238	235	288	278	293	9	12	2.5	2	59.2	0.43	1.4	0.78	10.3
	4FD	241	244	326	303	326	12	19	3	2.5	73.6	0.43	1.4	0.77	24.4
	—	247	267	382	350	367	11	18	4	3	74.6	0.40	1.5	0.82	33.6
32244 30344 32344	—	247	260	382	340	377	12	24	4	3	93.0	0.40	1.5	0.82	57.4
	—	253	283	438	390	414	12	24	5	4	85.3	0.36	1.7	0.92	72.4
	—	259	274	438	372	421	12	32	5	4	114.9	0.37	1.6	0.88	114
HR 32948 J HR 32048 XJ 30248	4EC	258	255	308	297	314	9	12	2.5	2	65.1	0.46	1.3	0.72	11.1
	4FD	261	262	346	321	346	12	19	3	2.5	79.1	0.46	1.3	0.72	26.2
	—	267	288	422	384	408	11	19	4	3	85.1	0.44	1.4	0.74	45.2
32248 30348 32348	—	267	285	422	374	416	12	27	4	3	102.5	0.40	1.5	0.82	78
	—	273	308	478	422	447	12	25	5	4	92.8	0.36	1.7	0.92	92.6
	—	279	301	478	410	464	12	33	5	4	123.2	0.37	1.6	0.88	145



Bore Diameter 260~440 mm

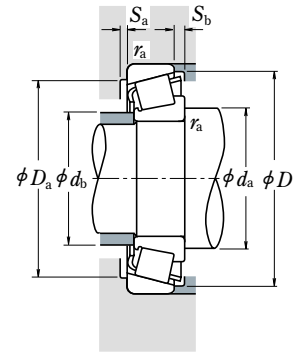
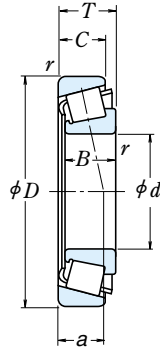

Dynamic Equivalent Load

$$P = XF_r + YF_a$$

$F_a/F_r \leq e$		$F_a/F_r > e$	
X	Y	X	Y
1	0	0.4	$Y_1$

Static Equivalent Load

$$P_0 = 0.5F_r + Y_0F_a$$

When  $F_r > 0.5F_r + Y_0F_a$ , use  $P_0 = F_r$

The values of  $e$ ,  $Y_1$ , and  $Y_0$  are given in the table below.

d	Boundary Dimensions (mm)				Cone		Basic Load Ratings				Limiting Speeds (rpm)	
	D	T	B	C	r	r <sub>min</sub>	C <sub>r</sub>	C <sub>0r</sub>	C <sub>r</sub>	C <sub>0r</sub>	Grease	Oil
260	360	63.5	63.5	48	3	2.5	730 000	1 450 000	74 500	148 000	850	1 100
	400	87	87	65	5	4	1 160 000	2 160 000	118 000	220 000	800	1 100
	480	89	80	67	6	5	1 190 000	1 700 000	121 000	174 000	670	900
280	480	137	130	106	6	5	1 900 000	3 300 000	194 000	335 000	670	950
	540	113	102	85	6	6	1 870 000	2 640 000	190 000	269 000	630	850
	540	176	165	136	6	6	2 910 000	4 800 000	297 000	490 000	630	850
300	420	76	72	62	4	3	895 000	1 820 000	91 000	186 000	710	950
	420	76	76	57	4	3	1 010 000	2 100 000	103 000	214 000	710	950
	460	100	100	74	5	4	1 440 000	2 700 000	147 000	275 000	670	900
320	540	96	85	71	6	5	1 440 000	2 100 000	147 000	214 000	600	800
	540	149	140	115	6	5	2 220 000	3 700 000	226 000	380 000	600	800
	440	76	72	63	4	3	900 000	1 880 000	92 000	192 000	970	900
340	440	76	76	57	4	3	1 040 000	2 220 000	106 000	227 000	670	900
	480	100	100	74	5	4	1 510 000	2 910 000	153 000	297 000	630	850
	580	104	92	75	6	5	1 640 000	2 420 000	168 000	247 000	530	750
360	580	159	150	125	6	5	2 860 000	5 050 000	292 000	515 000	530	750
	670	210	200	170	7.5	7.5	4 200 000	7 100 000	430 000	725 000	480	670
	460	76	72	63	4	3	910 000	1 940 000	93 000	197 000	630	850
380	460	76	76	57	4	3	1 050 000	2 220 000	107 000	226 000	630	850
	520	112	106	92	6	5	1 650 000	3 400 000	168 000	345 000	560	750
	480	76	72	62	4	3	945 000	2 100 000	965 000	214 000	600	800
400	480	76	76	57	4	3	1 080 000	2 340 000	110 000	239 000	560	800
	540	112	106	92	6	5	1 680 000	3 500 000	171 000	355 000	530	750
	520	87	82	71	5	4	1 210 000	2 550 000	124 000	260 000	560	750
420	540	87	82	71	5	4	1 250 000	2 700 000	128 000	276 000	530	710
	600	125	118	100	6	5	1 960 000	4 050 000	200 000	415 000	480	670
440	560	87	82	72	5	4	1 300 000	2 810 000	132 000	287 000	500	670
	620	125	118	100	6	5	2 000 000	4 200 000	204 000	430 000	450	630
440	650	130	122	104	6	6	2 230 000	4 600 000	227 000	470 000	430	600

Bearing Numbers	ISO355 Dimension Series approx	Abutment and Fillet Dimensions (mm)						Cone Cup r <sub>a</sub> max	Eff. Load Centers (mm) a	Constant e	Axial Load Factors		Mass (kg) approx		
		d <sub>a</sub> min	d <sub>b</sub> max	D <sub>a</sub> max	D <sub>b</sub> min	S <sub>a</sub> min	S <sub>b</sub> min				Y <sub>1</sub>	Y <sub>0</sub>			
HR 32952 J HR 32052 XJ 30252	3EC	278	278	348	333	347	11	15.5	2.5	2	69.8	0.41	1.5	0.81	18.6
	4FC	287	287	382	357	383	14	22	4	3	86.3	0.43	1.4	0.76	38.5
	—	293	316	458	421	447	12	22	5	4	94.5	0.44	1.4	0.74	60.7
32252 30352 32352	—	293	305	458	394	446	14	31	5	4	116.0	0.45	1.3	0.73	103
	—	293	336	512	460	487	16	28	5	5	101.6	0.36	1.7	0.92	114
	—	293	328	512	441	495	13	40	5	5	130.5	0.37	1.6	0.88	188
HR 32956 J HR 32056 XJ 30256	4EC	298	297	368	352	368	12	15.5	2.5	2	75.3	0.43	1.4	0.76	20
	4FC	307	305	402	374	402	14	22	4	3	91.6	0.46	1.3	0.72	40.6
	—	313	339	478	436	462	12	22	5	4	98.5	0.44	1.4	0.74	66.3
32256 32356	—	313	325	478	412	467	14	31	5	4	123.0	0.47	1.3	0.70	109
	—	319	353	552	475	532	14	42	5	5	139.6	0.37	1.6	0.89	224
	32960	—	321	326	406	386	405	13	14	3	2.5	79.3	0.37	1.6	0.88
HR 32960 J HR 32060 XJ	3FD	321	324	406	387	405	13	19	3	2.5	79.9	0.39	1.5	0.84	31.4
	4GD	327	330	442	408	439	15	26	4	3	98.4	0.43	1.4	0.76	56.6
	30260	—	333	355	518	470	499	14	25	5	4	105.1	0.44	1.4	0.74
32260	—	333	352	518	458	514	15	34	5	4	131.6	0.46	1.3	0.72	132
32964 HR 32964 J HR 32064 XJ	—	341	345	426	404	425	13	13	3	2.5	84.3	0.39	1.5	0.84	32
	3FD	341	344	426	406	426	13	19	3	2.5	85.0	0.42	1.4	0.79	33.3
	4GD	347	350	462	430	461	15	26	4	3	104.5	0.46	1.3	0.72	60
30264 32264 32364	—	353	381	558	503	533	14	29	5	4	113.7	0.44	1.4	0.74	99.3
	—	353	383	558	487	550	15	34	5	4	141.6	0.46	1.3	0.72	175
	—	383	412	634	547	616	14	42	6	6	157.5	0.37	1.6	0.88	343
32968 HR 32968 J 32068	—	361	364	446	426	446	13	13	3	2.5	89.2	0.41	1.5	0.80	33.6
	4FD	361	362	446	427	446	13	19	3	2.5	91.0	0.44	1.4	0.75	34.3
	—	373	386	498	464	496	3.5	22	5	4	104.4	0.37	1.6	0.89	83.7
32972 HR 32972 J 32072	—	381	386	466	445	465	14	14	3	2.5	91.4	0.40	1.5	0.82	35.8
	4FD	381	381	466	445	466	13	19	3	2.5	96.8	0.46	1.3	0.72	36.1
	—	393	402	518	480	514	5.5	22	5	4	108.5	0.38	1.6	0.86	86.5
32976	—	407	406	502	478	501	16	16	4	3	95.2	0.39	1.6	0.86	49.5
32980 32080	—	427	428	522	499	524	16	16	4	3	100.8	0.40	1.5	0.82	52.7
	—	433	443	578	533	565	5	25	5	4	115.3	0.36	1.7	0.92	116
32984 32084	—	447	448	542	521	544	3.5	15	4	3	106.1	0.41	1.5	0.81	54.8
	—	453	463	598	552	586	6.5	25	5	4	120.0	0.37	1.6	0.88	121
32088	—	473	487	622	582	616	5	26	5	5	126.3	0.36	1.7	0.92	136

# SINGLE-ROW TAPERED ROLLER BEARINGS (INCH DESIGN)

Bore Diameter 12.000~22.225 mm

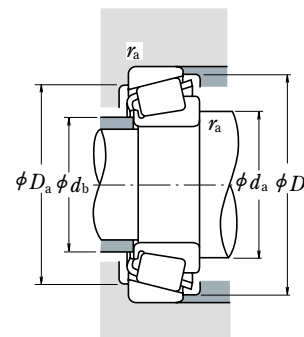
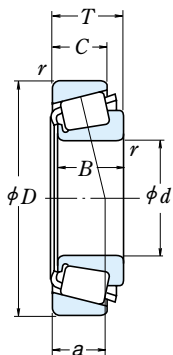

### Dynamic Equivalent Load

$$P = X F_r + Y F_a$$

$F_a/F_r \leq e$		$F_a/F_r > e$	
X	Y	X	Y
1	0	0.4	$Y_1$

### Static Equivalent Load

$$P_0 = 0.5 F_r + Y_0 F_a$$

When  $F_r > 0.5 F_r + Y_0 F_a$ , use  $P_0 = F_r$

The values of  $e$ ,  $Y_1$ , and  $Y_0$  are given in the table below.

Boundary Dimensions (mm)						Basic Load Ratings (N)				Limiting Speeds (rpm)	
$d$	$D$	$T$	$B$	$C$	Cone $r$ Cup $r$ min	$C_r$	$C_{0r}$	$C_r$	$C_{0r}$	Grease	Oil
12.000	31.991	10.008	10.785	7.938	0.8 1.3	10 300	8 900	1 050	905	13 000	18 000
12.700	34.988	10.998	10.988	8.730	1.3 1.3	11 700	10 900	1 200	1 110	12 000	16 000
15.000	34.988	10.998	10.988	8.730	0.8 1.3	11 700	10 900	1 200	1 110	12 000	16 000
15.875	34.988	10.998	10.998	8.712	1.3 1.3	13 800	13 400	1 410	1 360	11 000	15 000
	39.992	12.014	11.153	9.525	1.3 1.3	14 900	15 700	1 520	1 600	9 500	13 000
	41.275	14.288	14.681	11.112	1.3 2.0	21 300	19 900	2 170	2 030	10 000	13 000
	42.862	14.288	14.288	9.525	1.5 1.5	17 300	17 200	1 770	1 750	8 500	12 000
	42.862	16.670	16.670	13.495	1.5 1.5	26 900	26 300	2 750	2 680	9 500	13 000
	44.450	15.494	14.381	11.430	1.5 1.5	23 800	23 900	2 430	2 440	8 500	11 000
	49.225	19.845	21.539	14.288	0.8 1.3	37 500	37 000	3 800	3 800	8 500	11 000
16.000	47.000	21.000	21.000	16.000	1.0 2.0	35 000	36 500	3 600	3 750	9 000	12 000
16.993	39.992	12.014	11.153	9.525	0.8 1.3	14 900	15 700	1 520	1 600	9 500	13 000
17.455	36.525	11.112	11.112	7.938	1.5 1.5	11 600	11 000	1 190	1 120	10 000	14 000
17.462	39.878	13.843	14.605	10.668	1.3 1.3	22 500	22 500	2 290	2 290	10 000	13 000
	47.000	14.381	14.381	11.112	0.8 1.3	23 800	23 900	2 430	2 440	8 500	11 000
19.050	39.992	12.014	11.153	9.525	1.0 1.3	14 900	15 700	1 520	1 600	9 500	13 000
	45.237	15.494	16.637	12.065	1.3 1.3	28 500	28 900	2 910	2 950	9 000	12 000
	47.000	14.381	14.381	11.112	1.3 1.3	23 800	23 900	2 430	2 440	8 500	11 000
	49.225	18.034	19.050	14.288	1.3 1.3	37 500	37 000	3 800	3 800	8 500	11 000
	49.225	19.845	21.539	14.288	1.2 1.3	37 500	37 000	3 800	3 800	8 500	11 000
	49.225	21.209	19.050	17.462	1.3 1.5	37 500	37 000	3 800	3 800	8 500	11 000
	49.225	23.020	21.539	17.462	C1.5 3.5	37 500	37 000	3 800	3 800	8 500	11 000
	53.975	22.225	21.839	15.875	1.5 2.3	40 500	39 500	4 150	4 000	7 500	10 000
19.990	47.000	14.381	14.381	11.112	1.5 1.3	23 800	23 900	2 430	2 440	8 500	11 000
20.000	51.994	15.011	14.260	12.700	1.5 1.3	26 000	27 900	2 650	2 840	7 500	10 000
20.625	49.225	23.020	21.539	17.462	1.5 1.5	37 500	37 000	3 800	3 800	8 500	11 000
20.638	49.225	19.845	19.845	15.875	1.5 1.5	36 000	37 000	3 650	3 750	8 000	11 000
21.430	50.005	17.526	18.288	13.970	1.3 1.3	38 500	40 000	3 950	4 100	8 000	11 000
22.000	45.237	15.494	16.637	12.065	1.3 1.3	29 200	33 500	2 980	3 400	8 500	11 000
	45.975	15.494	16.637	12.065	1.3 1.3	29 200	33 500	2 980	3 400	8 500	11 000
22.225	50.005	13.495	14.260	9.525	1.3 1.0	26 000	27 900	2 650	2 840	7 500	10 000
	50.005	17.526	18.288	13.970	1.3 1.3	38 500	40 000	3 950	4 100	8 000	11 000
	52.388	19.368	20.168	14.288	1.5 1.5	40 500	43 000	4 100	4 400	7 500	10 000
	53.975	19.368	20.168	14.288	1.5 1.5	40 500	43 000	4 100	4 400	7 500	10 000
	56.896	19.368	19.837	15.875	1.3 1.3	38 000	40 500	3 900	4 150	7 100	9 500
	57.150	22.225	22.225	17.462	0.8 1.5	48 000	50 000	4 850	5 100	7 100	9 500

Bearing Numbers		Abutment and Fillet Dimensions (mm)				Eff. Load Centers (mm)	Constant	Axial Load Factors		Mass (kg)			
CONE	CUP	$d_a$	$d_b$	$D_a$	$D_b$	$a$	$e$	$Y_1$	$Y_0$	approx CONE	CUP		
*A 2047	A 2126	16.5	15.5	26	29	0.8	1.3	6.8	0.41	1.5	0.81	0.023	0.017
A 4050	A 4138	18.5	17	29	32	1.3	1.3	8.2	0.45	1.3	0.73	0.033	0.022
*A 4059	A 4138	19.5	19	29	32	0.8	1.3	8.2	0.45	1.3	0.73	0.029	0.022
L 21549	L 21511	21.5	19.5	29	32.5	1.3	1.3	7.7	0.32	1.9	1.0	0.031	0.018
A 6062	A 6157	22	20.5	34	37	1.3	1.3	10.3	0.53	1.1	0.63	0.044	0.031
03062	03162	21.5	20	34	37.5	1.3	2	9.1	0.31	1.9	1.1	0.061	0.035
11590	11520	24.5	22.5	34.5	39.5	1.5	1.5	13.0	0.70	0.85	0.47	0.061	0.040
17580	17520	23	21	36.5	39	1.5	1.5	10.6	0.33	1.8	1.0	0.075	0.048
05062	05175	23.5	21	38	42	1.5	1.5	11.2	0.36	1.7	0.93	0.081	0.039
09062	09195	22	21.5	42	44.5	0.8	1.3	10.7	0.27	2.3	1.2	0.139	0.065
*HM 81649	**HM 81610	27.5	23	37.5	43	1	2	14.9	0.55	1.1	0.60	0.115	0.082
A 6067	A 6157	22	21	34	37	0.8	1.3	10.3	0.53	1.1	0.63	0.042	0.031
A 5069	A 5144	23.5	21.5	30	33.5	1.5	1.5	8.9	0.49	1.2	0.68	0.030	0.020
† LM 11749	† LM 11710	23	21.5	34	37	1.3	1.3	8.7	0.29	2.1	1.2	0.055	0.028
05068	05185	23	22.5	40.5	42.5	0.8	1.3	10.1	0.36	1.7	0.93	0.082	0.047
A 6075	A 6157	24	23	34	37	1	1.3	10.3	0.53	1.1	0.63	0.037	0.031
† LM 11949	† LM 11910	25	23.5	39.5	41.5	1.3	1.3	9.5	0.30	2.0	1.1	0.081	0.044
05075	05185	25	23.5	40.5	42.5	1.3	1.3	10.1	0.36	1.7	0.93	0.077	0.047
09067	09195	25.5	24	42	44.5	1.3	1.3	10.7	0.27	2.3	1.2	0.115	0.065
09078	09195	25.5	24	42	44.5	1.2	1.3	10.7	0.27	2.3	1.2	0.124	0.065
09067	09196	25.5	24	41.5	44.5	1.3	1.5	13.8	0.27	2.3	1.2	0.115	0.085
09074	09194	26	24	39	44.5	1.5	3.5	13.8	0.27	2.3	1.2	0.124	0.082
21075	21212	31.5	26	43	50	1.5	2.3	16.3	0.59	1.0	0.56	0.156	0.097
05079	05185	26.5	24	40.5	42.5	1.5	1.3	10.1	0.36	1.7	0.93	0.073	0.047
07079	07204	27.5	27	45	48	1.5	1.3	12.1	0.40	1.5	0.82	0.105	0.061
09081	09196	27.5	25.5	41.5	44.5	1.5	1.5	13.8	0.27	2.3	1.2	0.115	0.085
12580	12520	28.5	26	42.5	45.5	1.5	1.5	12.9	0.32	1.9	1.0	0.114	0.067
† M 12649	† M 12610	27.5	25.5	44	46	1.3	1.3	10.9	0.28	2.2	1.2	0.115	0.059
*† LM 12749	† LM 12710	27.5	26	39.5	42.5	1.3	1.3	10.0	0.31	2.0	1.1	0.078	0.038
*† LM 12749	† LM 12711	27.5	26	40	42.5	1.3	1.3	10.0	0.31	2.0	1.1	0.078	0.043
07087	07196	28.5	27	44.5	47	1.3	1	10.6	0.40	1.5	0.82	0.097	0.035
† M 12648	† M 12610	28.5	26.5	44	46	1.3	1.3	10.9	0.28	2.2	1.2	0.111	0.059
1380	1328	29.5	27	45	48.5	1.5	1.5	11.3	0.29	2.1	1.1	0.137	0.067
1380	1329	29.5	27	46	49	1.5	1.5	11.3	0.29	2.1	1.1	0.137	0.082
1755	1729	29	27.5	49	51	1.3	1.3	12.2	0.31	2.0	1.1	0.152	0.102
1280	1220	29.5	29	49	52	0.8	1.5	15.1	0.35	1.7	0.95	0.183	0.106

- Notes**
- \* The maximum bore diameter is listed and its tolerance is negative (See Table 8.4.1 on Page A68).
  - \*\* The maximum outside diameter is listed and its tolerance is negative (See Table 8.4.2 on Pages A68 and A69).
  - † The tolerances for the bore diameter and overall bearing width differ from the standard (See Table 5 on Page B110).
  - \* † The tolerance for the bore diameter is 0 to  $-20 \mu\text{m}$ , and for overall bearing width is  $+356$  to  $0 \mu\text{m}$ .

# SINGLE-ROW TAPERED ROLLER BEARINGS (INCH DESIGN)

Bore Diameter 22.606~28.575 mm

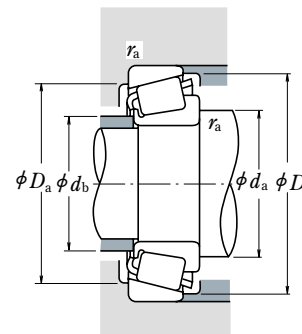
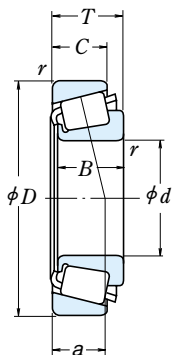

### Dynamic Equivalent Load

$$P = XF_r + YF_a$$

$F_a/F_r \leq e$		$F_a/F_r > e$	
X	Y	X	Y
1	0	0.4	$Y_1$

### Static Equivalent Load

$$P_0 = 0.5F_r + Y_0F_a$$

When  $F_r > 0.5F_r + Y_0F_a$ , use  $P_0 = F_r$

The values of  $e$ ,  $Y_1$ , and  $Y_0$  are given in the table below.

Boundary Dimensions (mm)					Basic Load Ratings (N)				Limiting Speeds (rpm)			
d	D	T	B	C	Cone r	Cup r	$C_r$	$C_{0r}$	$C_r$	$C_{0r}$	Grease	Oil
22.606	47.000	15.500	15.500	12.000	1.5	1.0	26 300	30 000	2 680	3 100	8 000	11 000
23.812	50.292	14.224	14.732	10.668	1.5	1.3	27 600	32 000	2 820	3 250	7 100	10 000
	56.896	19.368	19.837	15.875	0.8	1.3	38 000	40 500	3 900	4 150	7 100	9 500
24.000	55.000	25.000	25.000	21.000	2.0	2.0	49 500	55 000	5 050	5 650	7 100	9 500
24.981	51.994	15.011	14.260	12.700	1.5	1.3	26 000	27 900	2 650	2 840	7 500	10 000
	52.001	15.011	14.260	12.700	1.5	2.0	26 000	27 900	2 650	2 840	7 500	10 000
	62.000	16.002	16.566	14.288	1.5	1.5	37 000	39 500	3 750	4 000	6 300	8 500
25.000	50.005	13.495	14.260	9.525	1.5	1.0	26 000	27 900	2 650	2 840	7 500	10 000
	51.994	15.011	14.260	12.700	1.5	1.3	26 000	27 900	2 650	2 840	7 500	10 000
25.400	50.005	13.495	14.260	9.525	3.3	1.0	26 000	27 900	2 650	2 840	7 500	10 000
	50.005	13.495	14.260	9.525	1.0	1.0	26 000	27 900	2 650	2 840	7 500	10 000
	50.292	14.224	14.732	10.668	1.3	1.3	27 600	32 000	2 820	3 250	7 100	10 000
	57.150	17.462	17.462	13.495	1.3	1.5	39 500	45 500	4 050	4 650	6 700	9 000
	57.150	19.431	19.431	14.732	1.5	1.5	42 500	49 000	4 300	5 000	6 700	9 000
	59.530	23.368	23.114	18.288	0.8	1.5	50 000	58 000	5 100	5 900	6 300	9 000
	62.000	19.050	20.638	14.288	0.8	1.3	46 000	53 000	4 700	5 400	6 000	8 000
	63.500	20.638	20.638	15.875	3.5	1.5	46 000	53 000	4 700	5 400	6 000	8 000
	64.292	21.433	21.433	16.670	1.5	1.5	51 000	64 500	5 200	6 600	5 600	8 000
	65.088	22.225	21.463	15.875	1.5	1.5	45 000	47 500	4 600	4 850	5 600	8 000
	68.262	22.225	22.225	17.462	0.8	1.5	55 000	64 000	5 600	6 550	5 600	7 500
	72.233	25.400	25.400	19.842	0.8	2.3	63 500	83 500	6 500	8 500	5 000	7 100
	72.626	24.608	24.257	17.462	2.3	1.5	60 000	58 000	6 100	5 900	5 600	7 500
26.988	50.292	14.224	14.732	10.668	3.5	1.3	27 600	32 000	2 820	3 250	7 100	10 000
	57.150	19.845	19.355	15.875	3.3	1.5	40 000	44 500	4 100	4 500	6 700	9 000
	60.325	19.842	17.462	15.875	3.5	1.5	39 500	45 500	4 050	4 650	6 700	9 000
	62.000	19.050	20.638	14.288	0.8	1.3	46 000	53 000	4 700	5 400	6 000	8 000
28.575	57.150	19.845	19.355	15.875	3.5	1.5	40 000	44 500	4 100	4 500	6 700	9 000
	59.131	15.875	16.764	11.811	spec.	1.3	34 500	41 500	3 550	4 200	6 300	8 500
	62.000	19.050	20.638	14.288	3.5	1.3	46 000	53 000	4 700	5 400	6 000	8 000
	62.000	19.050	20.638	14.288	0.8	1.3	46 000	53 000	4 700	5 400	6 000	8 000
	64.292	21.433	21.433	16.670	1.5	1.5	51 000	64 500	5 200	6 600	5 600	8 000
	68.262	22.225	22.225	17.462	0.8	1.5	55 000	64 000	5 600	6 550	5 600	7 500
	72.626	24.608	24.257	17.462	4.8	1.5	60 000	58 000	6 100	5 900	5 600	7 500
	72.626	24.608	24.257	17.462	1.5	1.5	60 000	58 000	6 100	5 900	5 600	7 500
	73.025	22.225	22.225	17.462	0.8	3.3	54 500	64 500	5 550	6 600	5 300	7 100

Bearing Numbers		Abutment and Fillet Dimensions (mm)				Eff. Load Centers (mm)		Constant	Axial Load Factors		Mass (kg)	
CONE	CUP	$d_a$	$d_b$	$D_a$	$D_b$	Cone $r_a$	Cup $r_a$	$e$	$Y_1$	$Y_0$	approx CONE	CUP
LM 72849	LM 72810	29	27	40.5	44.5	1.5	1	12.2	0.47	1.3	0.086	0.046
† L 44640	† L 44610	30.5	28.5	44.5	47	1.5	1.3	10.9	0.37	1.6	0.097	0.039
1779	1729	29.5	28.5	49	51	0.8	1.3	12.2	0.31	2.0	0.143	0.102
▲ JHM 33449	▲ JHM 33410	35	30	47	52	2	2	15.8	0.35	1.7	0.093	0.181
07098	07204	31	29	45	48	1.5	1.3	12.1	0.40	1.5	0.082	0.085
07098	07205	31	29	44.5	48	1.5	2	12.1	0.40	1.5	0.082	0.085
17098	17244	33	30.5	54	57	1.5	1.5	12.8	0.38	1.6	0.086	0.165
07097	07196	31	29	44.5	47	1.5	1	10.6	0.40	1.5	0.082	0.085
07097	07204	31	29	45	48	1.5	1.3	12.1	0.40	1.5	0.082	0.085
07100 SA	07196	35	29.5	44.5	47	3.3	1	10.6	0.40	1.5	0.082	0.082
07100	07196	30.5	29.5	44.5	47	1	1	10.6	0.40	1.5	0.082	0.084
† L 44643	† L 44610	31.5	29.5	44.5	47	1.3	1.3	10.9	0.37	1.6	0.088	0.090
15578	15520	32.5	30.5	51	53	1.3	1.5	12.4	0.35	1.7	0.095	0.151
M 84548	M 84510	36	33	48.5	54	1.5	1.5	16.1	0.55	1.1	0.60	0.156
M 84249	M 84210	36	32.5	49.5	56	0.8	1.5	18.3	0.55	1.1	0.60	0.194
15101	15245	32.5	31.5	55	58	0.8	1.3	13.3	0.35	1.7	0.94	0.222
15100	15250 X	38	31.5	55	59	3.5	1.5	14.9	0.35	1.7	0.94	0.22
M 86643	M 86610	38	36.5	54	61	1.5	1.5	17.7	0.55	1.1	0.60	0.246
23100	23256	39	34.5	53	61	1.5	1.5	20.0	0.73	0.82	0.45	0.214
02473	02420	34.5	33.5	59	63	0.8	1.5	16.9	0.42	1.4	0.79	0.28
HM 88630	HM 88610	39.5	39.5	60	69	0.8	2.3	20.7	0.55	1.1	0.60	0.398
41100	41286	41	36.5	61	68	2.3	1.5	20.7	0.60	1.0	0.55	0.32
† L 44649	† L 44610	37.5	31	44.5	47	3.5	1.3	10.9	0.37	1.6	0.88	0.081
1997 X	1922	37.5	31.5	51	53.5	3.3	1.5	13.9	0.33	1.8	1.0	0.152
15580	15523	38.5	32	51	54	3.5	1.5	14.7	0.35	1.7	0.95	0.141
15106	15245	33.5	33	55	58	0.8	1.3	13.3	0.35	1.7	0.94	0.211
1988	1922	39.5	33.5	51	53.5	3.5	1.5	13.9	0.33	1.8	1.0	0.141
† LM 67043	† LM 67010	40	33.5	52	56	3.5	1.3	12.6	0.41	1.5	0.80	0.147
15112	15245	40	34	55	58	3.5	1.3	13.3	0.35	1.7	0.94	0.199
15113	15245	34.5	34	55	58	0.8	1.3	13.3	0.35	1.7	0.94	0.20
M 86647	M 86610	40	38	54	61	1.5	1.5	17.7	0.55	1.1	0.60	0.223
02474	02420	36.5	36	59	63	0.8	1.5	16.9	0.42	1.4	0.79	0.257
41125	41286	48	36.5	61	68	4.8	1.5	20.7	0.60	1.0	0.55	0.292
41126	41286	41.5	36.5	61	68	1.5	1.5	20.7	0.60	1.0	0.55	0.295
02872	02820	37.5	37	62	68	0.8	3.3	18.3	0.45	1.3	0.73	0.321

Notes † The tolerances for the bore diameter and overall bearing width differ from the standard (See Table 5 on Page B110).  
▲ The tolerances are listed in Tables 2, 3 and 4 on Pages B109 and B110.

# SINGLE-ROW TAPERED ROLLER BEARINGS (INCH DESIGN)

Bore Diameter 29.000~32.000 mm

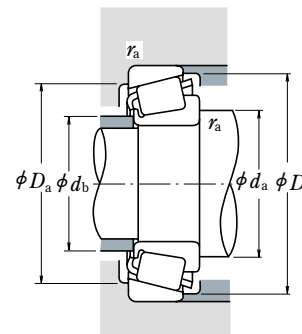
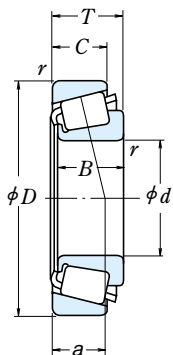

### Dynamic Equivalent Load

$$P = XF_r + YF_a$$

$F_a/F_r \leq e$		$F_a/F_r > e$	
X	Y	X	Y
1	0	0.4	$Y_1$

### Static Equivalent Load

$$P_0 = 0.5F_r + Y_0F_a$$

When  $F_r > 0.5F_r + Y_0F_a$ , use  $P_0 = F_r$

The values of  $e$ ,  $Y_1$ , and  $Y_0$  are given in the table below.

Boundary Dimensions (mm)					Basic Load Ratings (N)				Limiting Speeds (rpm)			
$d$	$D$	$T$	$B$	$C$	Cone $r$	Cup $r$	$C_r$	$C_{0r}$	$C_r$	$C_{0r}$	Grease	Oil
<b>29.000</b>	50.292	14.224	14.732	10.668	3.5	1.3	26 800	34 000	2 730	3 500	7 100	9 500
<b>29.367</b>	66.421	23.812	25.433	19.050	3.5	1.3	65 000	73 000	6 600	7 450	6 000	8 000
<b>30.000</b>	62.000	16.002	16.566	14.288	1.5	1.5	37 000	39 500	3 750	4 000	6 300	8 500
	62.000	19.050	20.638	14.288	1.3	1.3	46 000	53 000	4 700	5 400	6 000	8 000
	63.500	20.638	20.638	15.875	1.3	1.3	46 000	53 000	4 700	5 400	6 000	8 000
	72.000	19.000	18.923	15.875	1.5	1.5	52 000	56 000	5 300	5 700	5 600	7 500
<b>30.112</b>	62.000	19.050	20.638	14.288	0.8	1.3	46 000	53 000	4 700	5 400	6 000	8 000
<b>30.162</b>	58.738	14.684	15.080	10.716	3.5	1.0	28 800	33 500	2 940	3 450	6 000	8 000
	64.292	21.433	21.433	16.670	1.5	1.5	51 000	64 500	5 200	6 600	5 600	8 000
	68.262	22.225	22.225	17.462	2.3	1.5	55 500	70 500	5 650	7 200	5 300	7 500
	69.850	23.812	25.357	19.050	2.3	1.3	71 000	84 000	7 200	8 550	5 600	7 500
	69.850	23.812	25.357	19.050	0.8	1.3	71 000	84 000	7 200	8 550	5 600	7 500
	76.200	24.608	24.074	16.670	1.5	C3.3	67 500	69 500	6 850	7 100	5 000	6 700
<b>30.213</b>	62.000	19.050	20.638	14.288	3.5	1.3	46 000	53 000	4 700	5 400	6 000	8 000
	62.000	19.050	20.638	14.288	0.8	1.3	46 000	53 000	4 700	5 400	6 000	8 000
	62.000	19.050	20.638	14.288	1.5	1.3	46 000	53 000	4 700	5 400	6 000	8 000
<b>30.955</b>	64.292	21.433	21.433	16.670	1.5	1.5	51 000	64 500	5 200	6 600	5 600	8 000
<b>31.750</b>	58.738	14.684	15.080	10.716	1.0	1.0	28 800	33 500	2 940	3 450	6 000	8 000
	59.131	15.875	16.764	11.811	spec.	1.3	34 500	41 500	3 550	4 200	6 300	8 500
	62.000	18.161	19.050	14.288	spec.	1.3	46 000	53 000	4 700	5 400	6 000	8 000
	62.000	19.050	20.638	14.288	0.8	1.3	46 000	53 000	4 700	5 400	6 000	8 000
	62.000	19.050	20.638	14.288	3.5	1.3	46 000	53 000	4 700	5 400	6 000	8 000
	63.500	20.638	20.638	15.875	0.8	1.3	46 000	53 000	4 700	5 400	6 000	8 000
	68.262	22.225	22.225	17.462	3.5	1.5	55 000	64 000	5 600	6 550	5 600	7 500
	68.262	22.225	22.225	17.462	1.5	1.5	55 500	70 500	5 650	7 200	5 300	7 500
	69.012	19.845	19.583	15.875	3.5	1.3	47 000	56 000	4 800	5 700	5 600	7 500
	69.012	26.982	26.721	15.875	4.3	3.3	47 000	56 000	4 800	5 700	5 600	7 500
	69.850	23.812	25.357	19.050	0.8	1.3	71 000	84 000	7 200	8 550	5 600	7 500
	69.850	23.812	25.357	19.050	3.5	1.3	71 000	84 000	7 200	8 550	5 600	7 500
	72.626	30.162	29.997	23.812	0.8	3.3	79 500	90 000	8 100	9 200	5 300	7 500
	73.025	29.370	27.783	23.020	1.3	3.3	74 000	100 000	7 550	10 200	5 000	7 100
	80.000	21.000	22.403	17.826	0.8	1.3	68 500	75 500	6 950	7 700	4 500	6 300
<b>32.000</b>	72.233	25.400	25.400	19.842	3.3	2.3	63 500	83 500	6 500	8 500	5 000	7 100

Bearing Numbers		Abutment and Fillet Dimensions (mm)				Eff. Load Centers (mm)	Constant	Axial Load Factors		Mass (kg)	
CONE	CUP	$d_a$	$d_b$	$D_a$	$D_b$	$a$	$e$	$Y_1$	$Y_0$	approx CONE	CUP
† L 45449	† L 45410	39.5	33	44.5	48	3.5	1.3	10.8	0.37	1.6	0.89
2690	2631	41	35	58	60	3.5	1.3	14.3	0.25	2.4	1.3
* 17118	17244	37	34.5	54	57	1.5	1.5	12.8	0.38	1.6	0.86
* 15117	15245	36.5	35	55	58	1.3	1.3	13.3	0.35	1.7	0.94
* 15117	15250	36.5	35	56	59	1.3	1.3	14.9	0.35	1.7	0.94
* 26118	26283	38	36	62	65	1.5	1.5	14.8	0.36	1.7	0.92
15116	15245	36	35.5	55	58	0.8	1.3	13.3	0.35	1.7	0.94
08118	08231	41.5	35	52	55	3.5	1	13.3	0.47	1.3	0.70
M 86649	M 86610	41	38	54	61	1.5	1.5	17.7	0.55	1.1	0.60
M 88043	M 88010	43.5	39.5	58	65	2.3	1.5	19.1	0.55	1.1	0.60
2558	2523	40	36.5	61	64	2.3	1.3	14.5	0.27	2.2	1.2
2559	2523	37	36.5	61	64	0.8	1.3	14.5	0.27	2.2	1.2
43118	43300	45	42	64	73	1.5	3.3	22.9	0.67	0.90	0.49
15118	15245	41.5	35.5	55	58	3.5	1.3	13.3	0.35	1.7	0.94
15120	15245	36	35.5	55	58	0.8	1.3	13.3	0.35	1.7	0.94
15119	15245	37.5	35.5	55	58	1.5	1.3	13.3	0.35	1.7	0.94
M 86648 A	M 86610	42	38	54	61	1.5	1.5	17.7	0.55	1.1	0.60
08125	08231	37.5	36	52	55	1	1	13.3	0.47	1.3	0.70
† LM 67048	† LM 67010	42.5	36	52	56	3.5	1.3	12.6	0.41	1.5	0.80
15123	15245	42.5	36.5	55	58	3.5	1.3	13.3	0.35	1.7	0.94
15126	15245	37	36.5	55	58	0.8	1.3	13.3	0.35	1.7	0.94
15125	15245	42.5	36.5	55	58	3.5	1.3	13.3	0.35	1.7	0.94
15126	15250	37	36.5	56	59	0.8	1.3	14.9	0.35	1.7	0.94
02475	02420	44.5	38.5	59	63	3.5	1.5	16.9	0.42	1.4	0.79
M 88046	M 88010	43	40.5	58	65	1.5	1.5	19.1	0.55	1.1	0.60
14125 A	14276	44	37.5	60	63	3.5	1.3	15.3	0.38	1.6	0.86
14123 A	14274	41.5	37.5	59	63	4.3	3.3	15.1	0.38	1.6	0.87
2580	2523	38.5	37.5	61	64	0.8	1.3	14.5	0.27	2.2	1.2
2582	2523	44	37.5	61	64	3.5	1.3	14.5	0.27	2.2	1.2
3188	3120	39.5	39.5	61	67	0.8	3.3	19.6	0.33	1.8	0.99
HM 88542	HM 88510	45.5	42.5	59	70	1.3	3.3	23.5	0.55	1.1	0.60
346	332	40	39.5	73	75	0.8	1.3	14.6	0.27	2.2	1.2
*HM 88638	HM 88610	48.5	42.5	60	69	3.3	2.3	20.7	0.55	1.1	0.60

Notes \* The maximum bore diameter is listed and its tolerance is negative (See Table 8.4.1 on Page A68).  
† The tolerances for the bore diameter and overall bearing width differ from the standard (See Table 5 on Page B110).

# SINGLE-ROW TAPERED ROLLER BEARINGS (INCH DESIGN)

Bore Diameter 33.338~35.000 mm

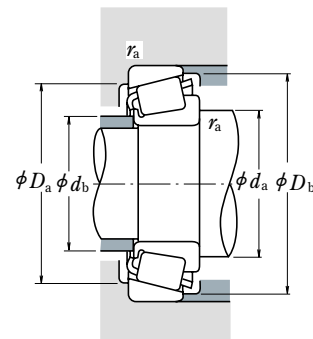
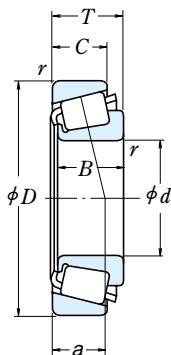

### Dynamic Equivalent Load

$$P = XF_r + YF_a$$

$F_a/F_r \leq e$		$F_a/F_r > e$	
X	Y	X	Y
1	0	0.4	$Y_1$

### Static Equivalent Load

$P_0 = 0.5F_r + Y_0F_a$   
 When  $F_r > 0.5F_r + Y_0F_a$ , use  $P_0 = F_r$   
 The values of  $e$ ,  $Y_1$ , and  $Y_0$  are given in the table below.

d	Boundary Dimensions (mm)					Cone r min	Cup r max	Basic Load Ratings (N) (kgf)				Limiting Speeds (rpm)	
	D	T	B	C	$C_r$			$C_{0r}$	$C_r$	$C_{0r}$	Grease	Oil	
33.338	66.675	20.638	20.638	15.875	3.5	1.5	46 000	53 500	4 650	5 450	5 600	7 500	
	68.262	22.225	22.225	17.462	0.8	1.5	55 500	70 500	5 650	7 200	5 300	7 500	
	69.012	19.845	19.583	15.875	3.5	3.3	47 000	56 000	4 800	5 700	5 600	7 500	
	69.012	19.845	19.583	15.875	0.8	1.3	47 000	56 000	4 800	5 700	5 600	7 500	
	69.850	23.812	25.357	19.050	3.5	1.3	71 000	84 000	7 200	8 550	5 600	7 500	
	72.000	19.000	18.923	15.875	3.5	1.5	52 000	56 000	5 300	5 700	5 600	7 500	
	72.626	30.162	29.997	23.812	0.8	3.3	79 500	90 000	8 100	9 200	5 300	7 500	
	73.025	29.370	27.783	23.020	0.8	3.3	74 000	100 000	7 550	10 200	5 000	7 100	
	76.200	29.370	28.575	23.020	3.8	0.8	78 500	106 000	8 000	10 800	4 800	6 700	
	76.200	29.370	28.575	23.020	0.8	3.3	78 500	106 000	8 000	10 800	4 800	6 700	
	79.375	25.400	24.074	17.462	3.5	1.5	67 500	69 500	6 850	7 100	5 000	6 700	
	34.925	65.088	18.034	18.288	13.970	spec.	1.3	47 500	57 500	4 850	5 900	5 600	7 500
65.088		20.320	18.288	16.256	spec.	1.3	47 500	57 500	4 850	5 900	5 600	7 500	
66.675		20.638	20.638	16.670	3.5	2.3	53 000	62 500	5 400	6 400	5 600	7 500	
69.012		19.845	19.583	15.875	3.5	1.3	47 000	56 000	4 800	5 700	5 600	7 500	
69.012		19.845	19.583	15.875	1.5	1.3	47 000	56 000	4 800	5 700	5 600	7 500	
72.233		25.400	25.400	19.842	2.3	2.3	63 500	83 500	6 500	8 500	5 000	7 100	
73.025		22.225	22.225	17.462	0.8	3.3	54 500	64 500	5 550	6 600	5 300	7 100	
73.025		22.225	23.812	17.462	3.5	3.3	63 500	77 000	6 500	7 850	5 300	7 100	
73.025		23.812	24.608	19.050	1.5	0.8	71 000	86 000	7 250	8 750	5 300	7 100	
73.025		23.812	24.608	19.050	3.5	2.3	71 000	86 000	7 250	8 750	5 300	7 100	
76.200		29.370	28.575	23.020	0.8	0.8	78 500	106 000	8 000	10 800	4 800	6 700	
76.200		29.370	28.575	23.020	3.5	0.8	78 500	106 000	8 000	10 800	4 800	6 700	
34.976	68.262	15.875	16.520	11.908	1.5	1.5	45 000	53 500	4 600	5 450	5 300	7 100	
	72.085	22.385	19.583	18.415	1.3	2.3	47 000	56 000	4 800	5 700	5 600	7 500	
	80.000	21.006	20.940	15.875	1.5	1.5	56 500	64 500	5 750	6 600	5 000	6 700	
	35.000	59.131	15.875	16.764	11.938	spec.	1.3	35 000	47 000	3 550	4 750	6 000	8 000
		59.975	15.875	16.764	11.938	spec.	1.3	35 000	47 000	3 550	4 750	6 000	8 000
		62.000	16.700	17.000	13.600	spec.	1.0	38 000	50 000	3 900	5 100	5 600	8 000
		62.000	16.700	17.000	13.600	spec.	1.5	38 000	50 000	3 900	5 100	5 600	8 000
		65.987	20.638	20.638	16.670	3.5	2.3	53 000	62 500	5 400	6 400	5 600	7 500
		73.025	26.988	26.975	22.225	3.5	0.8	75 500	88 500	7 650	9 050	5 300	7 500

Bearing Numbers		Abutment and Fillet Dimensions (mm)				Cone r max	Cup r max	Eff. Load Centers (mm) a	Constant e	Axial Load Factors		Mass (kg)	
CONE	CUP	da	db	Da	Db					Y1	Y0	approx CONE	CUP
<b>1680</b>	<b>1620</b>	44.5	38.5	58	61	3.5	1.5	15.2	0.37	1.6	0.89	0.196	0.121
<b>M 88048</b>	<b>M 88010</b>	42.5	41	58	65	0.8	1.5	19.0	0.55	1.1	0.60	0.236	0.146
<b>14130</b>	<b>14274</b>	45	38.5	59	63	3.5	3.3	15.3	0.38	1.6	0.86	0.207	0.132
<b>14131</b>	<b>14276</b>	39.5	38.5	60	63	0.8	1.3	15.3	0.38	1.6	0.86	0.209	0.135
<b>2585</b>	<b>2523</b>	45	39	61	64	3.5	1.3	14.5	0.27	2.2	1.2	0.263	0.169
<b>26131</b>	<b>26283</b>	44.5	38.5	62	65	3.5	1.5	14.7	0.36	1.7	0.92	0.20	0.163
<b>3197</b>	<b>3120</b>	41.5	40.5	61	67	0.8	3.3	19.6	0.33	1.8	0.99	0.348	0.225
<b>HM 88547</b>	<b>HM 88510</b>	45.5	42.5	59	70	0.8	3.3	23.5	0.55	1.1	0.60	0.362	0.242
<b>HM 89444</b>	<b>HM 89411</b>	53	44.5	65	73	3.8	0.8	23.6	0.55	1.1	0.60	0.419	0.261
<b>HM 89443</b>	<b>HM 89410</b>	46.5	44.5	62	73	0.8	3.3	23.6	0.55	1.1	0.60	0.421	0.257
<b>43131</b>	<b>43312</b>	51	42	67	74	3.5	1.5	23.7	0.67	0.90	0.49	0.348	0.22
† <b>LM 48548</b>	† <b>LM 48510</b>	46	40	58	61	3.5	1.3	14.1	0.38	1.6	0.88	0.172	0.087
† <b>LM 48548</b>	† <b>LM 48511</b>	46	40	58	61	3.5	1.3	16.4	0.38	1.6	0.88	0.172	0.108
<b>M 38549</b>	<b>M 38510</b>	46.5	40	58	62	3.5	2.3	15.2	0.35	1.7	0.94	0.194	0.112
<b>14138 A</b>	<b>14276</b>	46	40	60	63	3.5	1.3	15.3	0.38	1.6	0.86	0.194	0.135
<b>14137 A</b>	<b>14276</b>	42	40	60	63	1.5	1.3	15.1	0.38	1.6	0.86	0.196	0.135
<b>HM 88649</b>	<b>HM 88610</b>	48.5	42.5	60	69	2.3	2.3	20.7	0.55	1.1	0.60	0.307	0.188
<b>02878</b>	<b>02820</b>	42.5	42	62	68	0.8	3.3	18.3	0.45	1.3	0.73	0.266	0.16
<b>2877</b>	<b>2820</b>	47	41.5	63	68	3.5	3.3	16.1	0.37	1.6	0.90	0.291	0.15
<b>25877</b>	<b>25821</b>	43	40.5	65	68	1.5	0.8	15.7	0.29	2.1	1.1	0.306	0.167
<b>25878</b>	<b>25820</b>	47	40.5	64	68	3.5	2.3	15.7	0.29	2.1	1.1	0.304	0.165
<b>HM 89446 A</b>	<b>HM 89411</b>	47.5	44.5	65	73	0.8	0.8	23.6	0.55	1.1	0.60	0.403	0.261
<b>HM 89446</b>	<b>HM 89411</b>	53	44.5	65	73	3.5	0.8	23.6	0.55	1.1	0.60	0.40	0.261
<b>HM 89446</b>	<b>HM 89410</b>	53	44.5	62	73	3.5	3.3	23.6	0.55	1.1	0.60	0.40	0.257
<b>31594</b>	<b>31520</b>	46	43.5	64	72	1.5	3.3	21.6	0.40	1.5	0.82	0.404	0.235
<b>3478</b>	<b>3420</b>	50	43.5	67	74	3.5	3.3	20.0	0.37	1.6	0.90	0.448	0.259
<b>19138</b>	<b>19268</b>	42.5	40.5	61	65	1.5	1.5	14.5	0.44	1.4	0.74	0.196	0.073
<b>14139</b>	<b>14283</b>	41.5	40	60	65	1.3	2.3	17.7	0.38	1.6	0.87	0.198	0.21
<b>28138</b>	<b>28315</b>	43.5	41	69	73	1.5	1.5	16.0	0.40	1.5	0.82	0.308	0.199
* † <b>L 68149</b>	† <b>L 68110</b>	45.5	39	52	56	3.5	1.3	13.2	0.42	1.4	0.79	0.117	0.056
* † <b>L 68149</b>	† <b>L 68111</b>	45.5	39	53	56	3.5	1.3	13.2	0.42	1.4	0.79	0.117	0.064
* <b>LM 78349</b>	** <b>LM 78310</b>	46	40	55	59	3.5	1	14.4	0.44	1.4	0.74	0.137	0.074
* <b>LM 78349</b>	** <b>LM 78310 A</b>	46	40	54	59	3.5	1.5	14.4	0.44	1.4	0.74	0.138	0.073
<b>M 38547</b>	<b>M 38511</b>	46	39.5	59	61	3.5	2.3	15.2	0.35	1.7	0.94	0.193	0.103
<b>23691</b>	<b>23621</b>	49	42	63	68	3.5	0.8	18.1	0.37	1.6	0.89	0.309	0.212

- Notes**
- \* The maximum bore diameter is listed and its tolerance is negative (See Table 8.4.1 on Page A68).
  - \*\* The maximum outside diameter is listed and its tolerance is negative (See Table 8.4.2 on Pages A68 and A69).
  - † The tolerances for the bore diameter and overall bearing width differ from the standard (See Table 5 on Page B110).
  - \* † The tolerance for the bore diameter is 0 to -20 μm, and for overall bearing width is +356 to 0 μm.

# SINGLE-ROW TAPERED ROLLER BEARINGS (INCH DESIGN)

Bore Diameter 35.717~41.275 mm

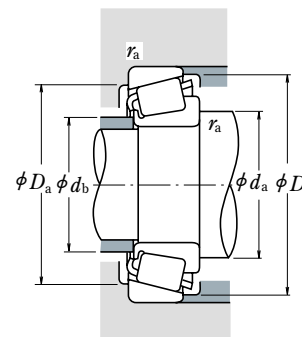
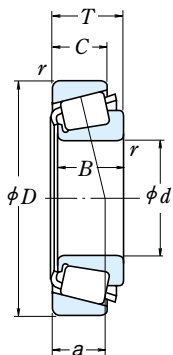

### Dynamic Equivalent Load

$$P = XF_r + YF_a$$

$F_a/F_r \leq e$		$F_a/F_r > e$	
X	Y	X	Y
1	0	0.4	$Y_1$

### Static Equivalent Load

$$P_0 = 0.5F_r + Y_0F_a$$

When  $F_r > 0.5F_r + Y_0F_a$ , use  $P_0 = F_r$

The values of  $e$ ,  $Y_1$ , and  $Y_0$  are given in the table below.

Boundary Dimensions (mm)					Basic Load Ratings (N)				Limiting Speeds (rpm)			
$d$	$D$	$T$	$B$	$C$	Cone $r$	Cup $r$	$C_r$	$C_{0r}$	$C_r$	$C_{0r}$	Grease	Oil
<b>35.717</b>	72.233	25.400	25.400	19.842	3.5	2.3	63 500	83 500	6 500	8 500	5 000	7 100
<b>36.487</b>	73.025	23.812	24.608	19.050	1.5	0.8	71 000	86 000	7 250	8 750	5 300	7 100
<b>36.512</b>	76.200	29.370	28.575	23.020	3.5	3.3	78 500	106 000	8 000	10 800	4 800	6 700
	79.375	29.370	29.771	23.812	0.8	3.3	88 000	106 000	8 950	10 800	4 800	6 700
	88.501	25.400	23.698	17.462	2.3	1.5	73 000	81 000	7 450	8 250	4 000	5 600
	93.662	31.750	31.750	26.195	1.5	3.3	110 000	142 000	11 200	14 400	4 000	5 600
<b>38.000</b>	63.000	17.000	17.000	13.500	spec.	1.3	38 500	52 000	3 900	5 300	5 600	7 500
<b>38.100</b>	63.500	12.700	11.908	9.525	1.5	0.8	24 100	30 500	2 460	3 100	5 300	7 100
	65.088	18.034	18.288	13.970	2.3	1.3	42 500	55 000	4 300	5 650	5 300	7 500
	65.088	18.034	18.288	13.970	spec.	1.3	42 500	55 000	4 300	5 650	5 300	7 500
	65.088	19.812	18.288	15.748	2.3	1.3	42 500	55 000	4 300	5 650	5 300	7 500
	68.262	15.875	16.520	11.908	1.5	1.5	45 000	53 500	4 600	5 450	5 300	7 100
	69.012	19.050	19.050	15.083	2.0	2.3	49 000	61 000	4 950	6 250	5 300	7 100
	69.012	19.050	19.050	15.083	3.5	0.8	49 000	61 000	4 950	6 250	5 300	7 100
	72.238	20.638	20.638	15.875	3.5	1.3	48 500	59 500	4 950	6 050	5 300	7 100
	73.025	23.812	25.654	19.050	3.5	0.8	73 500	91 000	7 500	9 300	5 000	6 700
	76.200	23.812	25.654	19.050	3.5	3.3	73 500	91 000	7 500	9 300	5 000	6 700
	76.200	23.812	25.654	19.050	3.5	0.8	73 500	91 000	7 500	9 300	5 000	6 700
	79.375	29.370	29.771	23.812	3.5	3.3	88 000	106 000	8 950	10 800	4 800	6 700
	80.035	24.608	23.698	18.512	0.8	1.5	69 000	84 500	7 000	8 600	4 500	6 300
	82.550	29.370	28.575	23.020	0.8	3.3	87 000	117 000	8 850	11 900	4 500	6 000
	88.501	25.400	23.698	17.462	2.3	1.5	73 000	81 000	7 450	8 250	4 000	5 600
	88.501	26.988	29.083	22.225	3.5	1.5	96 500	109 000	9 800	11 100	4 500	6 000
	95.250	30.958	28.301	20.638	1.5	0.8	87 500	97 000	8 950	9 850	3 600	5 300
<b>39.688</b>	73.025	25.654	22.098	21.336	0.8	2.3	62 500	80 000	6 400	8 150	5 000	6 700
	76.200	23.812	25.654	19.050	3.5	3.3	73 500	91 000	7 500	9 300	5 000	6 700
	80.167	29.370	30.391	23.812	0.8	3.3	92 500	108 000	9 450	11 000	4 800	6 300
<b>40.000</b>	80.000	21.000	22.403	17.826	3.5	1.3	68 500	75 500	6 950	7 700	4 500	6 300
	80.000	21.000	22.403	17.826	0.8	1.3	68 500	75 500	6 950	7 700	4 500	6 300
	88.501	25.400	23.698	17.462	2.3	1.5	73 000	81 000	7 450	8 250	4 000	5 600
<b>41.000</b>	68.000	17.500	18.000	13.500	spec.	1.5	43 500	58 000	4 450	5 950	5 300	7 100
<b>41.275</b>	73.025	16.667	17.462	12.700	3.5	1.5	44 500	54 000	4 550	5 500	4 800	6 700
	73.431	19.558	19.812	14.732	3.5	0.8	54 500	67 000	5 550	6 850	4 800	6 700
	73.431	21.430	19.812	16.604	3.5	0.8	54 500	67 000	5 550	6 850	4 800	6 700

Bearing Numbers		Abutment and Fillet Dimensions (mm)				Eff. Load Centers (mm)	Constant	Axial Load Factors		Mass (kg)	
CONE	CUP	$d_a$	$d_b$	$D_a$	$D_b$	$a$	$e$	$Y_1$	$Y_0$	approx CONE	CUP
<b>HM 88648</b>	<b>HM 88610</b>	52	43	60	69	3.5	2.3	20.7	0.55	1.1	0.60
<b>25880</b>	<b>25821</b>	44	42	65	68	1.5	0.8	15.7	0.29	2.1	1.1
<b>HM 89449</b>	<b>HM 89410</b>	54	44.5	62	73	3.5	3.3	23.6	0.55	1.1	0.60
<b>3479</b>	<b>3420</b>	45.5	44.5	67	74	0.8	3.3	20.0	0.37	1.6	0.90
<b>44143</b>	<b>44348</b>	54	50	75	84	2.3	1.5	27.9	0.78	0.77	0.42
<b>46143</b>	<b>46368</b>	48.5	46.5	79	87	1.5	3.3	24.0	0.40	1.5	0.82
<b>▲ JL 69349</b>	<b>▲ JL 69310</b>	49	42.5	56	60	3.5	1.3	14.6	0.42	1.4	0.79
<b>13889</b>	<b>13830</b>	45	42.5	59	60	1.5	0.8	11.9	0.35	1.7	0.95
<b>LM 29749</b>	<b>LM 29710</b>	46	42.5	59	62	2.3	1.3	13.7	0.33	1.8	0.99
<b>LM 29748</b>	<b>LM 29710</b>	49	42.5	59	62	3.5	1.3	13.7	0.33	1.8	0.99
<b>LM 29749</b>	<b>LM 29711</b>	46	42.5	58	62	2.3	1.3	15.5	0.33	1.8	0.99
<b>19150</b>	<b>19268</b>	45	43	61	65	1.5	1.5	14.5	0.44	1.4	0.74
<b>13687</b>	<b>13621</b>	46.5	43	61	65	2	2.3	15.8	0.40	1.5	0.82
<b>13685</b>	<b>13620</b>	49.5	43	62	65	3.5	0.8	15.8	0.40	1.5	0.82
<b>16150</b>	<b>16284</b>	49.5	43	63	67	3.5	1.3	16.0	0.40	1.5	0.82
<b>2788</b>	<b>2735 X</b>	50	43.5	66	69	3.5	0.8	15.9	0.30	2.0	1.1
<b>2788</b>	<b>2720</b>	50	43.5	66	70	3.5	3.3	15.9	0.30	2.0	1.1
<b>2788</b>	<b>2729</b>	50	43.5	68	70	3.5	0.8	15.9	0.30	2.0	1.1
<b>3490</b>	<b>3420</b>	52	45.5	67	74	3.5	3.3	20.0	0.37	1.6	0.90
<b>27880</b>	<b>27820</b>	48	47	68	75	0.8	1.5	21.5	0.56	1.1	0.59
<b>HM 801346</b>	<b>HM 801310</b>	51	49	68	78	0.8	3.3	24.2	0.55	1.1	0.60
<b>44150</b>	<b>44348</b>	55	51	75	84	2.3	1.5	27.9	0.78	0.77	0.42
<b>418</b>	<b>414</b>	51	44.5	77	80	3.5	1.5	17.1	0.26	2.3	1.3
<b>53150</b>	<b>53375</b>	55	53	81	89	1.5	0.8	30.7	0.74	0.81	0.45
<b>M 201047</b>	<b>M 201011</b>	45.5	48	64	69	0.8	2.3	19.7	0.33	1.8	0.99
<b>2789</b>	<b>2720</b>	52	45	66	70	3.5	3.3	15.9	0.30	2.0	1.1
<b>3386</b>	<b>3320</b>	46.5	45.5	70	75	0.8	3.3	18.4	0.27	2.2	1.2
<b>344</b>	<b>332</b>	52	45.5	73	75	3.5	1.3	14.5	0.27	2.2	1.2
<b>344 A</b>	<b>332</b>	46	45.5	73	75	0.8	1.3	14.5	0.27	2.2	1.2
<b>44157</b>	<b>44348</b>	56	51	75	84	2.3	1.5	27.9	0.78	0.77	0.42
<b>* LM 300849</b>	<b>** LM 300811</b>	52	45	61	65	3.5	1.5	13.9	0.35	1.7	0.95
<b>18590</b>	<b>18520</b>	53	46	66	69	3.5	1.5	14.0	0.35	1.7	0.94
<b>LM 501349</b>	<b>LM 501310</b>	53	46.5	67	70	3.5	0.8	16.3	0.40	1.5	0.83
<b>LM 501349</b>	<b>LM 501314</b>	53	46.5	66	70	3.5	0.8	18.2	0.40	1.5	0.83

- Notes**
- \* The maximum bore diameter is listed and its tolerance is negative (See Table 8.4.1 on Page A68).
  - \*\* The maximum outside diameter is listed and its tolerance is negative (See Table 8.4.2 on Pages A68 and A69).
  - ▲ The tolerances are listed in Tables 2, 3 and 4 on Pages B109 and B110.



# SINGLE-ROW TAPERED ROLLER BEARINGS (INCH DESIGN)

Bore Diameter 41.275~44.450 mm

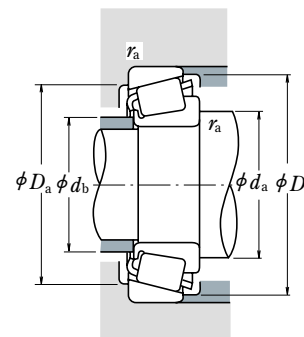
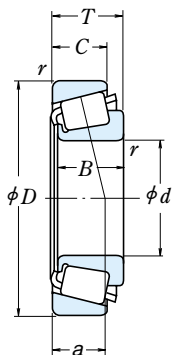

### Dynamic Equivalent Load

$$P = XF_r + YF_a$$

$F_a/F_r \leq e$		$F_a/F_r > e$	
X	Y	X	Y
1	0	0.4	$Y_1$

### Static Equivalent Load

$P_0 = 0.5F_r + Y_0F_a$   
 When  $F_r > 0.5F_r + Y_0F_a$ , use  $P_0 = F_r$   
 The values of  $e$ ,  $Y_1$ , and  $Y_0$  are given in the table below.

d	Boundary Dimensions (mm)					Cone r min	Cup r max	Basic Load Ratings (kgf)				Limiting Speeds (rpm)	
	D	T	B	C	$C_r$			$C_{0r}$	$C_r$	$C_{0r}$	Grease	Oil	
41.275	76.200	18.009	17.384	14.288	1.5	1.5	42 500	51 000	4 350	5 200	4 500	6 300	
	76.200	22.225	23.020	17.462	3.5	0.8	66 000	82 000	6 700	8 400	4 800	6 700	
	76.200	25.400	23.020	20.638	3.5	2.3	66 000	82 000	6 700	8 400	4 800	6 700	
	79.375	23.812	25.400	19.050	3.5	0.8	77 000	98 500	7 850	10 000	4 800	6 300	
	80.000	21.000	22.403	17.826	0.8	1.3	68 500	75 500	6 950	7 700	4 500	6 300	
	80.000	21.000	22.403	17.826	3.5	1.3	68 500	75 500	6 950	7 700	4 500	6 300	
	80.167	25.400	25.400	20.638	3.5	3.3	77 000	98 500	7 850	10 000	4 800	6 300	
	82.550	26.543	25.654	20.193	3.5	3.3	78 500	102 000	8 000	10 400	4 300	6 000	
	85.725	30.162	30.162	23.812	3.5	3.3	91 000	115 000	9 300	11 700	4 300	6 000	
	87.312	30.162	30.886	23.812	0.8	3.3	96 000	120 000	9 800	12 200	4 300	6 000	
42.862	88.501	25.400	23.698	17.462	2.3	1.5	73 000	81 000	7 450	8 250	4 000	5 600	
	88.900	30.162	29.370	23.020	3.5	3.3	96 500	129 000	9 800	13 200	4 000	5 600	
	88.900	30.162	29.370	23.020	0.8	3.3	96 500	129 000	9 800	13 200	4 000	5 600	
	90.488	39.688	40.386	33.338	3.5	3.3	139 000	180 000	14 200	18 400	4 300	5 600	
	93.662	31.750	31.750	26.195	0.8	3.3	110 000	142 000	11 200	14 400	4 000	5 600	
	95.250	30.162	29.370	23.020	3.5	3.3	106 000	143 000	10 800	14 500	3 800	5 300	
	98.425	30.958	28.301	20.638	1.5	0.8	87 500	97 000	8 950	9 850	3 600	5 300	
	76.992	17.462	17.145	11.908	1.5	1.5	44 000	54 000	4 450	5 500	4 500	6 000	
	82.550	19.842	19.837	15.080	2.3	1.5	58 500	69 000	5 950	7 050	4 500	6 300	
	82.931	23.812	25.400	19.050	2.3	0.8	76 500	99 000	7 800	10 100	4 500	6 000	
42.875	82.931	26.988	25.400	22.225	2.3	2.3	76 500	99 000	7 800	10 100	4 500	6 000	
	76.200	25.400	25.400	20.638	3.5	1.5	77 000	98 500	7 850	10 000	4 800	6 300	
	80.000	21.000	22.403	17.826	3.5	1.3	68 500	75 500	6 950	7 700	4 500	6 300	
	82.931	26.988	25.400	22.225	3.5	2.3	76 500	99 000	7 800	10 100	4 500	6 000	
	83.058	23.812	25.400	19.050	3.5	3.3	76 500	99 000	7 800	10 100	4 500	6 000	
	74.988	19.368	19.837	14.288	1.5	1.3	52 500	68 000	5 350	6 900	4 800	6 300	
	43.000	80.962	19.050	17.462	14.288	0.3	1.5	45 000	57 000	4 600	5 800	4 300	6 000
		82.931	23.812	25.400	19.050	3.5	0.8	76 500	99 000	7 800	10 100	4 500	6 000
		83.058	23.812	25.400	19.050	3.5	3.3	76 500	99 000	7 800	10 100	4 500	6 000
		87.312	30.162	30.886	23.812	3.5	3.3	96 000	120 000	9 800	12 200	4 300	6 000
88.900		30.162	29.370	23.020	3.5	3.3	96 500	129 000	9 800	13 200	4 000	5 600	
93.264		30.162	30.302	23.812	3.5	3.2	103 000	136 000	10 500	13 900	3 800	5 300	
93.662		31.750	31.750	25.400	0.8	3.3	120 000	147 000	12 200	15 000	4 000	5 600	
93.662		31.750	31.750	25.400	3.5	3.3	120 000	147 000	12 200	15 000	4 000	5 600	
93.662		31.750	31.750	26.195	3.5	3.3	110 000	142 000	11 200	14 400	4 000	5 600	
95.250		27.783	29.901	22.225	3.5	2.3	106 000	126 000	10 800	12 900	4 300	5 600	

Bearing Numbers		Abutment and Fillet Dimensions (mm)						Eff. Load Centers (mm) a	Constant e	Axial Load Factors		Mass (kg)		
CONE	CUP	$d_a$	$d_b$	$D_a$	$D_b$	Cone r max	Cup r max			$Y_1$	$Y_0$	approx CONE	CUP	
11162	11300	49	46.5	67	71	1.5	1.5	17.4	0.49	1.2	0.68	0.212	0.129	
	24780	24720	53	47.5	68	72	3.5	0.8	17.0	0.39	1.5	0.84	0.279	0.15
	24780	24721	54	47	66	72	3.5	2.3	20.2	0.39	1.5	0.84	0.279	0.189
	26882	26822	54	47	71	74	3.5	0.8	16.4	0.32	1.9	1.0	0.349	0.186
	336	332	47	46	73	75	0.8	1.3	14.5	0.27	2.2	1.2	0.325	0.146
	342	332	53	46	73	75	3.5	1.3	14.5	0.27	2.2	1.2	0.323	0.146
	26882	26820	54	47	69	74	3.5	3.3	18.0	0.32	1.9	1.0	0.349	0.219
	M 802048	M 802011	57	51	70	79	3.5	3.3	22.9	0.55	1.1	0.60	0.406	0.23
	3877	3820	57	50	73	81	3.5	3.3	21.8	0.40	1.5	0.82	0.506	0.285
	3576	3525	49	48	75	81	0.8	3.3	19.5	0.31	2.0	1.1	0.532	0.304
HM 803146	HM 803110	57	51	75	84	2.3	1.5	28.0	0.78	0.77	0.42	0.447	0.245	
	4388	4335	57	51	77	85	3.5	3.3	24.6	0.28	2.1	1.2	0.789	0.459
	46162	46368	52	51	79	87	0.8	3.3	24.0	0.40	1.5	0.82	0.695	0.405
	HM 804840	HM 804810	61	54	81	91	3.5	3.3	26.1	0.55	1.1	0.60	0.726	0.354
	53162	53387	57	53	82	91	1.5	0.8	30.7	0.74	0.81	0.45	0.618	0.442
	12168	12303	51	48.5	68	73	1.5	1.5	17.7	0.51	1.2	0.65	0.228	0.098
	22168	22325	52	48.5	73	76	2.3	1.5	17.6	0.43	1.4	0.77	0.283	0.176
	25578	25520	53	49.5	74	77	2.3	0.8	17.6	0.33	1.8	0.99	0.383	0.203
	25578	25523	53	49.5	72	77	2.3	2.3	20.8	0.33	1.8	0.99	0.383	0.248
	26884	26823	55	48.5	69	73	3.5	1.5	18.0	0.32	1.9	1.0	0.337	0.136
* 16986	342 S	332	54	47.5	73	75	3.5	1.3	14.5	0.27	2.2	1.2	0.305	0.146
	25577	25523	55	49	72	77	3.5	2.3	20.8	0.33	1.8	0.99	0.381	0.248
	25577	25521	55	49	72	77	3.5	3.3	17.6	0.33	1.8	0.99	0.381	0.201
	16986	16929	51	48.5	67	71	1.5	1.3	17.2	0.44	1.4	0.74	0.24	0.106
	13175	13318	50	50	72	76	0.3	1.5	20.1	0.53	1.1	0.63	0.252	0.144
	25580	25520	57	50	74	77	3.5	0.8	17.6	0.33	1.8	0.99	0.359	0.203
	25580	25521	56	51	72	78	3.5	3.3	17.6	0.33	1.8	0.99	0.359	0.201
	3578	3525	57	51	75	81	3.5	3.3	19.5	0.31	2.0	1.1	0.477	0.304
	HM 803149	HM 803110	62	53	74	85	3.5	3.3	25.6	0.55	1.1	0.60	0.528	0.322
	3782	3720	58	52	82	88	3.5	3.2	22.4	0.34	1.8	0.97	0.678	0.292
49176	49368	54	53	82	87	0.8	3.3	21.6	0.36	1.7	0.92	0.648	0.371	
49175	49368	59	53	82	87	3.5	3.3	21.6	0.36	1.7	0.92	0.645	0.371	
46176	46368	60	54	79	87	3.5	3.3	24.0	0.40	1.5	0.82	0.635	0.405	
438	432	57	51	83	87	3.5	2.3	18.6	0.28	2.1	1.2	0.555	0.384	

Note \* The maximum bore diameter is listed and its tolerance is negative (See Table 8.4.1 on Page A68).

# SINGLE-ROW TAPERED ROLLER BEARINGS (INCH DESIGN)

Bore Diameter 44.450~47.625 mm

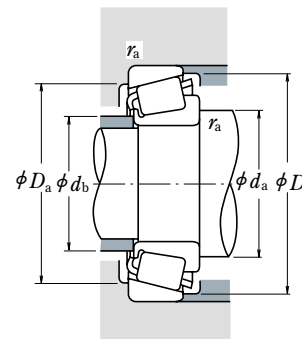
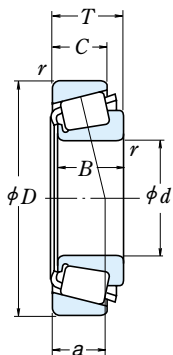

### Dynamic Equivalent Load

$$P = XF_r + YF_a$$

$F_a/F_r \leq e$		$F_a/F_r > e$	
X	Y	X	Y
1	0	0.4	$Y_1$

### Static Equivalent Load

$P_0 = 0.5F_r + Y_0F_a$   
 When  $F_r > 0.5F_r + Y_0F_a$ , use  $P_0 = F_r$   
 The values of  $e$ ,  $Y_1$ , and  $Y_0$  are given in the table below.

Boundary Dimensions (mm)					Basic Load Ratings (N)				Limiting Speeds (rpm)			
$d$	$D$	$T$	$B$	$C$	Cone $r$	Cup $r$	$C_r$	$C_{0r}$	$C_r$	$C_{0r}$	Grease	Oil
<b>44.450</b>	95.250	30.162	29.370	23.020	3.5	3.3	106 000	143 000	10 800	14 500	3 800	5 300
	95.250	30.958	28.301	20.638	3.5	0.8	87 500	97 000	8 950	9 850	3 600	5 300
	95.250	30.958	28.301	20.638	1.3	0.8	87 500	97 000	8 950	9 850	3 600	5 300
	95.250	30.958	28.301	20.638	2.0	0.8	87 500	97 000	8 950	9 850	3 600	5 300
	95.250	30.958	28.301	22.225	1.3	0.8	100 000	122 000	10 200	12 500	3 600	5 000
	95.250	30.958	28.575	22.225	3.5	0.8	100 000	122 000	10 200	12 500	3 600	5 000
	98.425	30.958	28.301	20.638	3.5	0.8	87 500	97 000	8 950	9 850	3 600	5 300
	103.188	43.658	44.475	36.512	1.3	3.3	178 000	238 000	18 100	24 300	3 800	5 000
	104.775	36.512	36.512	28.575	3.5	3.3	139 000	192 000	14 200	19 600	3 400	4 800
	107.950	27.783	29.317	22.225	3.5	0.8	116 000	149 000	11 800	15 200	3 400	4 800
<b>44.983</b>	95.250	30.162	26.909	20.638	3.5	3.3	92 500	110 000	9 450	11 200	3 200	4 300
	114.300	44.450	44.450	34.925	3.5	3.3	172 000	205 000	17 500	20 900	3 600	4 800
	82.931	23.812	25.400	19.050	1.5	0.8	76 500	99 000	7 800	10 100	4 500	6 000
	93.264	20.638	22.225	15.082	0.8	1.3	77 000	93 000	7 900	9 500	3 800	5 300
	79.985	19.842	20.638	15.080	2.0	1.3	62 000	78 500	6 300	8 000	4 500	6 000
	73.431	19.558	19.812	15.748	3.5	0.8	53 500	75 000	5 450	7 650	4 800	6 300
	77.788	19.842	19.842	15.080	3.5	0.8	56 000	71 000	5 700	7 250	4 500	6 300
	77.788	21.430	19.842	16.667	3.5	0.8	56 000	71 000	5 700	7 250	4 500	6 300
	82.931	23.812	25.400	19.050	3.5	0.8	76 500	99 000	7 800	10 100	4 500	6 000
	82.931	26.988	25.400	22.225	3.5	2.3	76 500	99 000	7 800	10 100	4 500	6 000
<b>45.230</b>	75.000	18.000	18.000	14.000	2.3	1.5	51 000	71 500	5 200	7 300	4 500	6 300
	79.375	17.462	17.462	13.495	2.8	1.5	46 000	57 000	4 700	5 800	4 500	6 000
	80.962	19.050	17.462	14.288	0.8	1.5	45 000	57 000	4 600	5 800	4 300	6 000
	85.000	20.638	21.692	17.462	2.3	1.3	71 500	81 500	7 300	8 300	4 300	6 000
	85.000	25.400	25.608	20.638	3.5	1.3	79 500	105 000	8 100	10 700	4 300	6 000
	95.250	27.783	29.901	22.225	3.5	0.8	106 000	126 000	10 800	12 900	4 300	5 600
	88.900	20.638	22.225	16.513	3.5	1.3	73 000	85 000	7 450	8 650	4 000	5 600
	88.900	25.400	25.400	19.050	3.5	3.3	86 000	107 000	8 750	10 900	4 000	5 600
	95.250	30.162	29.370	23.020	3.5	3.3	106 000	143 000	10 800	14 500	3 800	5 300
	101.600	34.925	36.068	26.988	3.5	3.3	137 000	169 000	14 000	17 200	3 800	5 000
<b>45.242</b>	111.125	30.162	26.909	20.638	3.5	3.3	92 500	110 000	9 450	11 200	3 200	4 300
	112.712	30.162	26.909	20.638	3.5	3.3	92 500	110 000	9 450	11 200	3 200	4 300
	117.475	33.338	31.750	23.812	3.5	3.3	137 000	156 000	13 900	15 900	3 200	4 300
	123.825	36.512	32.791	25.400	3.5	3.3	143 000	160 000	14 600	16 400	3 000	4 000

Bearing Numbers		Abutment and Fillet Dimensions (mm)				Eff. Load Centers (mm)	Constant	Axial Load Factors		Mass (kg)	
CONE	CUP	$d_a$	$d_b$	$D_a$	$D_b$	$a$	$e$	$Y_1$	$Y_0$	approx CONE	CUP
<b>HM 804843</b>	<b>HM 804810</b>	63	57	81	91	3.5	3.3	26.1	0.55	1.1	0.60
	<b>53177</b>	<b>53375</b>	63	53	81	89	3.5	0.8	30.7	0.74	0.81
	<b>53176</b>	<b>53375</b>	59	53	81	89	1.3	0.8	30.7	0.74	0.81
	<b>53178</b>	<b>53375</b>	60	53	81	89	2	0.8	30.7	0.74	0.81
	<b>HM 903247</b>	<b>HM 903210</b>	61	54	81	91	1.3	0.8	31.5	0.74	0.81
	<b>HM 903249</b>	<b>HM 903210</b>	65	54	81	91	3.5	0.8	31.5	0.74	0.81
	<b>53177</b>	<b>53387</b>	63	53	82	91	3.5	0.8	30.7	0.74	0.81
	<b>5356</b>	<b>5335</b>	58	56	89	97	1.3	3.3	27.0	0.30	2.0
	<b>HM 807040</b>	<b>HM 807010</b>	66	59	89	100	3.5	3.3	29.7	0.49	1.2
	<b>460</b>	<b>453 A</b>	60	54	97	100	3.5	0.8	20.7	0.34	1.8
<b>55175</b>	<b>55437</b>	67	60	92	105	3.5	3.3	37.3	0.88	0.68	
<b>65385</b>	<b>65320</b>	65	59	97	107	3.5	3.3	32.2	0.43	1.4	
<b>25584</b>	<b>25520</b>	53	51	74	77	1.5	0.8	17.6	0.33	1.8	
<b>376</b>	<b>374</b>	54	54	85	88	0.8	1.3	17.1	0.34	1.8	
<b>17887</b>	<b>17831</b>	57	52	68	74	2	1.3	15.9	0.37	1.6	
<b>LM 102949</b>	<b>LM 102910</b>	56	50	68	70	3.5	0.8	14.6	0.31	2.0	
<b>LM 603049</b>	<b>LM 603011</b>	57	50	71	74	3.5	0.8	17.2	0.43	1.4	
<b>LM 603049</b>	<b>LM 603012</b>	57	50	70	74	3.5	0.8	18.8	0.43	1.4	
<b>25590</b>	<b>25520</b>	58	51	74	77	3.5	0.8	17.6	0.33	1.8	
<b>25590</b>	<b>25523</b>	58	51	72	77	3.5	2.3	20.8	0.33	1.8	
<b>* LM 503349</b>	<b>** LM 503310</b>	55	51	67	71	2.3	1.5	15.9	0.40	1.5	
<b>18690</b>	<b>18620</b>	56	51	71	74	2.8	1.5	15.5	0.37	1.6	
<b>13181</b>	<b>13318</b>	52	52	72	76	0.8	1.5	20.1	0.53	1.1	
<b>359 S</b>	<b>354 A</b>	55	51	77	80	2.3	1.3	15.4	0.31	2.0	
<b>2984</b>	<b>2924</b>	58	52	76	80	3.5	1.3	19.0	0.35	1.7	
<b>436</b>	<b>432 A</b>	59	52	84	87	3.5	0.8	18.6	0.28	2.1	
<b>369 A</b>	<b>362 A</b>	60	53	81	84	3.5	1.3	16.6	0.32	1.9	
<b>M 804049</b>	<b>M 804010</b>	63	56	77	85	3.5	3.3	23.8	0.55	1.1	
<b>HM 804846</b>	<b>HM 804810</b>	66	57	81	91	3.5	3.3	26.1	0.55	1.1	
<b>528</b>	<b>522</b>	62	55	89	95	3.5	3.3	22.1	0.29	2.1	
<b>55187</b>	<b>55437</b>	69	62	92	105	3.5	3.3	37.3	0.88	0.68	
<b>55187</b>	<b>55443</b>	69	62	92	106	3.5	3.3	37.3	0.88	0.68	
<b>66187</b>	<b>66462</b>	66	62	100	111	3.5	3.3	32.1	0.63	0.96	
<b>72187</b>	<b>72487</b>	72	66	102	116	3.5	3.3	37.0	0.74	0.81	

Notes \* The maximum bore diameter is listed and its tolerance is negative (See Table 8.4.1 on Page A68).  
 \*\* The maximum outside diameter is listed and its tolerance is negative (See Table 8.4.2 on Pages A68 and A69).

# SINGLE-ROW TAPERED ROLLER BEARINGS (INCH DESIGN)

Bore Diameter 48.412~52.388 mm

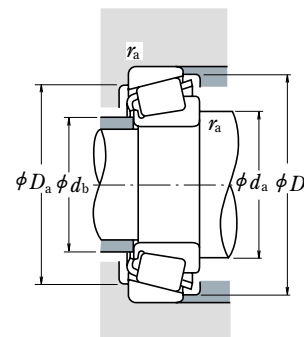
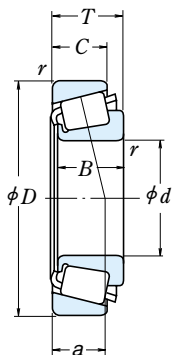

### Dynamic Equivalent Load

$$P = XF_r + YF_a$$

$F_a/F_r \leq e$		$F_a/F_r > e$	
X	Y	X	Y
1	0	0.4	$Y_1$

### Static Equivalent Load

$$P_0 = 0.5F_r + Y_0F_a$$

When  $F_r > 0.5F_r + Y_0F_a$ , use  $P_0 = F_r$

The values of  $e$ ,  $Y_1$ , and  $Y_0$  are given in the table below.

Boundary Dimensions (mm)					Basic Load Ratings (N)				Limiting Speeds (rpm)			
$d$	$D$	$T$	$B$	$C$	Cone $r$	Cup $r$	$C_r$	$C_{0r}$	$C_r$	$C_{0r}$	Grease	Oil
48.412	95.250	30.162	29.370	23.020	3.5	3.3	106 000	143 000	10 800	14 500	3 800	5 300
	95.250	30.162	29.370	23.020	2.3	3.3	106 000	143 000	10 800	14 500	3 800	5 300
49.212	104.775	36.512	36.512	28.575	3.5	0.8	139 000	192 000	14 200	19 600	3 400	4 800
	114.300	44.450	44.450	36.068	3.5	3.3	196 000	243 000	20 000	24 800	3 400	4 800
50.000	82.000	21.500	21.500	17.000	3.0	0.5	71 000	96 000	7 250	9 800	4 300	5 600
	82.550	21.590	22.225	16.510	0.5	1.3	71 000	96 000	7 250	9 800	4 300	5 600
	88.900	20.638	22.225	16.513	2.3	1.3	73 000	85 000	7 450	8 650	4 000	5 600
	90.000	28.000	28.000	23.000	3.0	2.5	104 000	136 000	10 600	13 900	4 000	5 600
50.800	105.000	37.000	36.000	29.000	3.0	2.5	139 000	192 000	14 200	19 600	3 400	4 800
	80.962	18.258	18.258	14.288	1.5	1.5	53 000	81 000	5 400	8 250	4 300	5 600
82.550	23.622	22.225	18.542	3.5	0.8	71 000	96 000	7 250	9 800	4 300	5 600	
	82.931	21.590	22.225	16.510	3.5	1.3	71 000	96 000	7 250	9 800	4 300	5 600
85.000	17.462	17.462	13.495	3.5	1.5	48 500	63 000	4 950	6 450	4 300	5 600	
	85.725	19.050	18.263	12.700	1.5	1.5	42 500	54 000	4 350	5 500	4 000	5 300
88.900	20.638	22.225	16.513	3.5	1.3	73 000	85 000	7 450	8 650	4 000	5 600	
	88.900	20.638	22.225	16.513	1.5	1.3	73 000	85 000	7 450	8 650	4 000	5 600
92.075	24.608	25.400	19.845	3.5	0.8	84 500	117 000	8 600	11 900	4 000	5 300	
	93.264	30.162	30.302	23.812	0.8	0.8	103 000	136 000	10 500	13 900	3 800	5 300
93.264	30.162	30.302	23.812	3.5	0.8	103 000	136 000	10 500	13 900	3 800	5 300	
	95.250	27.783	28.575	22.225	3.5	2.3	110 000	144 000	11 200	14 700	3 800	5 300
101.600	31.750	31.750	25.400	3.5	3.3	118 000	150 000	12 100	15 200	3 600	5 000	
	101.600	34.925	36.068	26.988	0.8	3.3	137 000	169 000	14 000	17 200	3 800	5 000
101.600	34.925	36.068	26.988	3.5	3.3	137 000	169 000	14 000	17 200	3 800	5 000	
	104.775	36.512	36.512	28.575	3.5	0.8	139 000	192 000	14 200	19 600	3 400	4 800
104.775	36.512	36.512	28.575	3.5	3.3	139 000	192 000	14 200	19 600	3 400	4 800	
	108.966	34.925	36.512	26.988	3.5	3.3	145 000	181 000	14 700	18 500	3 600	4 800
111.125	30.162	26.909	20.638	3.5	3.3	113 000	152 000	11 500	15 400	3 000	4 300	
	111.125	30.162	26.909	20.638	3.5	3.3	92 500	110 000	9 450	11 200	3 200	4 300
123.825	36.512	32.791	25.400	3.5	3.3	162 000	199 000	16 500	20 300	2 800	4 000	
	123.825	36.512	32.791	25.400	3.5	3.3	143 000	160 000	14 600	16 400	3 000	4 000
127.000	44.450	44.450	34.925	3.5	3.3	199 000	258 000	20 200	26 300	3 000	4 000	
	127.000	50.800	52.388	41.275	3.5	3.3	236 000	300 000	24 000	31 000	3 200	4 300
52.388	92.075	24.608	25.400	19.845	3.5	0.8	84 500	117 000	8 600	11 900	4 000	5 300
	100.000	25.000	22.225	21.824	2.3	2.0	77 000	93 000	7 900	9 500	3 800	5 300
	111.125	30.162	26.909	20.638	3.5	3.3	92 500	110 000	9 450	11 200	3 200	4 300

Bearing Numbers		Abutment and Fillet Dimensions (mm)				Eff. Load Centers (mm)		Constant	Axial Load Factors		Mass (kg)	
CONE	CUP	$d_a$	$d_b$	$D_a$	$D_b$	Cone $r_a$	Cup $r_a$	$a$	$e$	$Y_1$	$Y_0$	approx CONE CUP
HM 804849	HM 804810	66	57	81	91	3.5	3.3	26.1	0.55	1.1	0.60	0.61 0.354
HM 804848	HM 804810	63	57	81	91	2.3	3.3	26.1	0.55	1.1	0.60	0.614 0.354
HM 807044	HM 807011	69	63	91	100	3.5	0.8	29.7	0.49	1.2	0.68	1.03 0.508
HH 506348	HH 506310	71	61	97	107	3.5	3.3	30.8	0.40	1.5	0.82	1.43 0.837
▲ JLM 104948	▲ JLM 104910	60	55	76	78	3	0.5	16.1	0.31	2.0	1.1	0.306 0.129
* LM 104947 A	LM 104911	55	55	75	78	0.5	1.3	15.7	0.31	2.0	1.1	0.316 0.133
366	362 A	59	55	81	84	2.3	1.3	16.6	0.32	1.9	1.0	0.351 0.166
▲ JM 205149	▲ JM 205110	62	57	80	85	3	2.5	19.9	0.33	1.8	1.0	0.507 0.246
▲ JHM 807045	▲ JHM 807012	69	63	90	100	3	2.5	29.7	0.49	1.2	0.68	1.01 0.523
L 305649	L 305610	58	56	73	77	1.5	1.5	15.7	0.36	1.7	0.93	0.239 0.119
LM 104949	LM 104911 A	62	55	75	78	3.5	0.8	17.8	0.31	2.0	1.1	0.303 0.156
LM 104949	LM 104912	62	55	75	78	3.5	1.3	15.7	0.31	2.0	1.1	0.301 0.14
18790	18720	62	56	77	80	3.5	1.5	16.7	0.41	1.5	0.81	0.239 0.136
18200	18337	59	56	76	81	1.5	1.5	21.0	0.57	1.1	0.58	0.268 0.136
368 A	362 A	62	56	81	84	3.5	1.3	16.6	0.32	1.9	1.0	0.338 0.166
368	362 A	58	56	81	84	1.5	1.3	16.6	0.32	1.9	1.0	0.341 0.166
28580	28521	63	57	83	87	3.5	0.8	20.0	0.38	1.6	0.87	0.46 0.247
3775	3730	58	58	84	88	0.8	0.8	22.4	0.34	1.8	0.97	0.568 0.297
3780	3730	64	58	84	88	3.5	0.8	22.4	0.34	1.8	0.97	0.564 0.297
33889	33821	64	58	85	90	3.5	2.3	19.8	0.33	1.8	1.0	0.601 0.267
49585	49520	66	59	88	96	3.5	3.3	23.4	0.40	1.5	0.82	0.744 0.389
529	522	59	58	89	95	0.8	3.3	22.1	0.29	2.1	1.2	0.822 0.416
529 X	522	65	58	89	95	3.5	3.3	22.1	0.29	2.1	1.2	0.819 0.416
HM 807046	HM 807011	70	63	91	100	3.5	0.8	29.7	0.49	1.2	0.68	0.992 0.508
HM 807046	HM 807010	70	63	89	100	3.5	3.3	29.7	0.49	1.2	0.68	0.993 0.502
59200	59429	68	61	93	101	3.5	3.3	25.4	0.40	1.5	0.82	0.943 0.594
55200 C	55437	71	65	92	105	3.5	3.3	37.6	0.88	0.68	0.37	0.845 0.514
55200	55437	71	64	92	105	3.5	3.3	37.3	0.88	0.68	0.37	0.767 0.514
72200 C	72487	77	67	102	116	3.5	3.3	38.0	0.74	0.81	0.45	1.33 0.79
72200	72487	74	66	102	116	3.5	3.3	37.0	0.74	0.81	0.45	1.22 0.79
65200	65500	75	69	107	119	3.5	3.3	35.0	0.49	1.2	0.68	1.86 1.03
6279	6220	71	65	108	117	3.5	3.3	30.7	0.30	2.0	1.1	2.08 1.22
28584	28521	65	58	83	87	3.5	0.8	20.0	0.38	1.6	0.87	0.435 0.247
377	372	62	58	86	90	2.3	2	21.4	0.34	1.8	0.97	0.392 0.435
55206	55437	72	64	92	105	3.5	3.3	37.3	0.88	0.68	0.37	0.737 0.514

Notes \* The maximum bore diameter is listed and its tolerance is negative (See Table 8.4.1 on Page A68).

▲ The tolerances are listed in Tables 2, 3 and 4 on Pages B109 and B110.

# SINGLE-ROW TAPERED ROLLER BEARINGS (INCH DESIGN)

Bore Diameter 53.975~58.738 mm

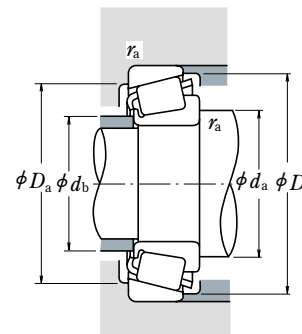
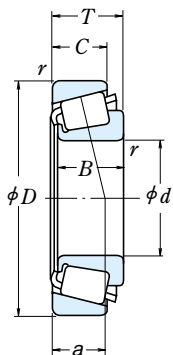

### Dynamic Equivalent Load

$$P = X F_r + Y F_a$$

$F_a / F_r \leq e$		$F_a / F_r > e$	
X	Y	X	Y
1	0	0.4	$Y_1$

### Static Equivalent Load

$$P_0 = 0.5 F_r + Y_0 F_a$$

When  $F_r > 0.5 F_r + Y_0 F_a$ , use  $P_0 = F_r$

The values of  $e$ ,  $Y_1$ , and  $Y_0$  are given in the table below.

Boundary Dimensions (mm)					Cone		Basic Load Ratings (N)				Limiting Speeds (rpm)	
$d$	$D$	$T$	$B$	$C$	$r_{min}$	Cup	$C_r$	$C_{0r}$	$C_r$	$C_{0r}$	Grease	Oil
<b>53.975</b>	104.775	39.688	40.157	33.338	3.5	3.3	150 000	210 000	15 300	21 400	3 600	4 800
	107.950	36.512	36.957	28.575	3.5	3.3	144 000	182 000	14 700	18 500	3 600	4 800
	122.238	33.338	31.750	23.812	3.5	3.3	135 000	156 000	13 800	15 900	3 000	4 000
	123.825	36.512	32.791	25.400	3.5	3.3	143 000	160 000	14 600	16 400	3 000	4 000
	123.825	36.512	32.791	25.400	3.5	3.3	162 000	199 000	16 500	20 300	2 800	4 000
	123.825	38.100	36.678	30.162	3.5	3.3	161 000	221 000	16 400	22 500	3 000	4 000
	127.000	44.450	44.450	34.925	3.5	3.3	199 000	258 000	20 200	26 300	3 000	4 000
	127.000	50.800	52.388	41.275	3.5	3.3	236 000	300 000	24 000	31 000	3 200	4 300
	130.175	36.512	33.338	23.812	3.5	3.3	133 000	154 000	13 600	15 700	2 600	3 600
	<b>55.000</b>	90.000	23.000	23.000	18.500	1.5	0.5	79 000	111 000	8 050	11 300	3 800
95.000		29.000	29.000	23.500	1.5	2.5	111 000	152 000	11 300	15 500	3 800	5 000
96.838		21.000	21.946	15.875	2.3	0.8	80 500	100 000	8 200	10 200	3 600	5 000
<b>55.562</b>	110.000	39.000	39.000	32.000	3.0	2.5	177 000	225 000	18 000	23 000	3 400	4 500
	115.000	41.021	41.275	31.496	3.0	3.0	172 000	214 000	17 500	21 800	3 200	4 500
<b>57.150</b>	97.630	24.608	24.608	19.446	3.5	0.8	89 000	129 000	9 100	13 100	3 600	5 000
	122.238	43.658	43.764	36.512	1.3	3.3	198 000	292 000	20 200	29 700	3 000	4 000
	123.825	36.512	32.791	25.400	3.5	3.3	143 000	160 000	14 600	16 400	3 000	4 000
	123.825	36.512	32.791	25.400	3.5	3.3	162 000	199 000	16 500	20 300	2 800	4 000
<b>57.531</b>	96.838	21.000	21.946	15.875	3.5	0.8	80 500	100 000	8 200	10 200	3 600	5 000
	96.838	21.000	21.946	15.875	2.3	0.8	80 500	100 000	8 200	10 200	3 600	5 000
	96.838	25.400	21.946	20.275	3.5	2.3	80 500	100 000	8 200	10 200	3 600	5 000
	98.425	21.000	21.946	17.826	3.5	0.8	80 500	100 000	8 200	10 200	3 600	5 000
	104.775	30.162	29.317	24.605	3.5	3.3	116 000	149 000	11 800	15 200	3 400	4 800
	104.775	30.162	29.317	24.605	2.3	3.3	116 000	149 000	11 800	15 200	3 400	4 800
	104.775	30.162	30.958	23.812	0.8	3.3	130 000	170 000	13 300	17 400	3 400	4 800
	104.775	30.162	30.958	23.812	0.8	0.8	130 000	170 000	13 300	17 400	3 400	4 800
	122.238	33.338	31.750	23.812	3.5	3.3	135 000	156 000	13 800	15 900	3 000	4 000
	123.825	36.512	32.791	25.400	3.5	3.3	162 000	199 000	16 500	20 300	2 800	4 000
<b>58.738</b>	123.825	38.100	36.678	30.162	3.5	3.3	161 000	221 000	16 400	22 500	3 000	4 000
	140.030	36.512	33.236	23.520	3.5	2.3	152 000	183 000	15 500	18 700	2 600	3 600
	144.983	36.000	33.236	23.007	3.5	3.5	152 000	183 000	15 500	18 700	2 600	3 600
	149.225	53.975	54.229	44.450	3.5	3.3	287 000	410 000	29 300	41 500	2 600	3 400
	96.838	21.000	21.946	15.875	3.5	0.8	80 500	100 000	8 200	10 200	3 600	5 000
	112.712	33.338	30.048	26.988	3.5	3.3	120 000	173 000	12 200	17 700	3 200	4 300

Bearing Numbers		Abutment and Fillet Dimensions (mm)				Eff. Load Centers (mm)		Constant	Axial Load Factors		Mass (kg)		
CONE	CUP	$d_a$	$d_b$	$D_a$	$D_b$	Cone $r_a$	Cup $r_a$	$e$	$Y_1$	$Y_0$	approx CONE	CUP	
<b>4595</b>	<b>4535</b>	70	63	90	99	3.5	3.3	27.4	0.33	1.8	0.99	0.972	0.583
	<b>539</b>	68	61	94	100	3.5	3.3	24.3	0.30	2.0	1.1	0.88	0.57
	<b>66584</b>	75	68	105	116	3.5	3.3	34.3	0.67	0.90	0.50	1.2	0.558
	<b>72212</b>	77	66	102	116	3.5	3.3	37.0	0.74	0.81	0.45	1.16	0.79
	<b>72212 C</b>	79	67	102	116	3.5	3.3	38.0	0.74	0.81	0.45	1.27	0.79
	<b>557 S</b>	71	65	109	116	3.5	3.3	28.8	0.35	1.7	0.95	1.49	0.764
	<b>65212</b>	77	71	107	119	3.5	3.3	35.0	0.49	1.2	0.68	1.76	1.03
	<b>6280</b>	74	67	108	117	3.5	3.3	30.7	0.30	2.0	1.1	1.97	1.22
	<b>HM911242</b>	79	74	109	124	3.5	3.3	42.2	0.82	0.73	0.40	1.45	0.725
	<b>▲ JLM506849</b>	<b>▲ JLM506810</b>	63	61	82	86	1.5	0.5	19.7	0.40	1.5	0.82	0.378
<b>▲ JM207049</b>	<b>▲ JM207010</b>	64	62	85	91	1.5	2.5	21.3	0.33	1.8	0.99	0.59	0.26
<b>385</b>	<b>382 A</b>	65	61	89	92	2.3	0.8	17.6	0.35	1.7	0.93	0.455	0.179
<b>▲ JH307749</b>	<b>▲ JH307710</b>	71	64	97	104	3	2.5	27.2	0.35	1.7	0.95	1.13	0.567
<b>622 X</b>	<b>614 X</b>	70	64	101	108	3	3	26.6	0.31	1.9	1.1	1.3	0.597
<b>28680</b>	<b>28622</b>	68	62	88	92	3.5	0.8	21.3	0.40	1.5	0.82	0.499	0.27
<b>5566</b>	<b>5535</b>	70	68	106	116	1.3	3.3	29.9	0.36	1.7	0.92	1.76	0.815
<b>72218</b>	<b>72487</b>	78	66	102	116	3.5	3.3	37.0	0.74	0.81	0.45	1.12	0.79
<b>72218 C</b>	<b>72487</b>	80	67	102	116	3.5	3.3	38.0	0.74	0.81	0.45	1.23	0.79
<b>387 A</b>	<b>382 A</b>	69	62	89	92	3.5	0.8	17.6	0.35	1.7	0.93	0.42	0.179
<b>387</b>	<b>382 A</b>	66	62	89	92	2.3	0.8	17.6	0.35	1.7	0.93	0.423	0.179
<b>387 A</b>	<b>382 S</b>	69	62	87	91	3.5	2.3	22.0	0.35	1.7	0.93	0.42	0.249
<b>387 A</b>	<b>382</b>	69	62	90	92	3.5	0.8	17.6	0.35	1.7	0.93	0.42	0.226
<b>469</b>	<b>453 X</b>	70	63	92	98	3.5	3.3	23.1	0.34	1.8	0.98	0.692	0.376
<b>462</b>	<b>453 X</b>	67	63	92	98	2.3	3.3	23.1	0.34	1.8	0.98	0.694	0.376
<b>45289</b>	<b>45220</b>	65	65	93	99	0.8	3.3	21.9	0.33	1.8	0.99	0.752	0.347
<b>45289</b>	<b>45221</b>	65	65	95	99	0.8	0.8	21.9	0.33	1.8	0.99	0.76	0.35
<b>66587</b>	<b>66520</b>	77	71	105	116	3.5	3.3	34.3	0.67	0.90	0.50	1.14	0.558
<b>72225 C</b>	<b>72487</b>	81	67	102	116	3.5	3.3	38.0	0.74	0.81	0.45	1.19	0.79
<b>555 S</b>	<b>552 A</b>	83	68	109	116	3.5	3.3	28.8	0.35	1.7	0.95	1.41	0.764
<b>78225</b>	<b>78551</b>	83	77	117	132	3.5	2.3	44.2	0.87	0.69	0.38	1.67	0.926
<b>78225</b>	<b>78571</b>	83	77	118	132	3.5	3.5	43.6	0.87	0.69	0.38	1.68	1.08
<b>6455</b>	<b>6420</b>	81	75	129	140	3.5	3.3	39.0	0.36	1.7	0.91	3.49	1.63
<b>388 A</b>	<b>382 A</b>	69	63	89	92	3.5	0.8	17.6	0.35	1.7	0.93	0.416	0.179
<b>3981</b>	<b>3926</b>	73	67	98	106	3.5	3.3	28.7	0.40	1.5	0.82	0.899	0.541

Note ▲ The tolerances are listed in Tables 2, 3 and 4 on Pages B109 and B110.

# SINGLE-ROW TAPERED ROLLER BEARINGS (INCH DESIGN)

Bore Diameter 60.000~64.963 mm

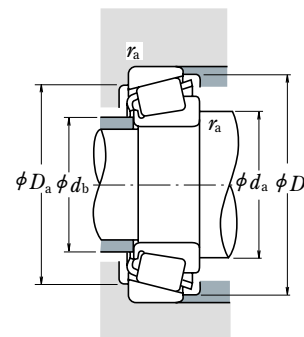
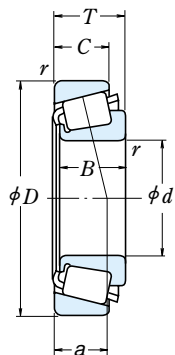

### Dynamic Equivalent Load

$$P = XF_r + YF_a$$

$F_a/F_r \leq e$		$F_a/F_r > e$	
X	Y	X	Y
1	0	0.4	$Y_1$

### Static Equivalent Load

$P_0 = 0.5F_r + Y_0F_a$   
 When  $F_r > 0.5F_r + Y_0F_a$ , use  $P_0 = F_r$   
 The values of  $e$ ,  $Y_1$ , and  $Y_0$  are given in the table below.

Boundary Dimensions (mm)						Basic Load Ratings (N) (kgf)				Limiting Speeds (rpm)		
$d$	$D$	$T$	$B$	$C$	Cone $r$	Cup	$C_r$	$C_{0r}$	$C_r$	$C_{0r}$	Grease	Oil
<b>60.000</b>	95.000	24.000	24.000	19.000	5.0	2.5	86 500	125 000	8 800	12 800	3 600	5 000
	104.775	21.433	22.000	15.875	2.3	2.0	83 500	107 000	8 500	10 900	3 400	4 500
	110.000	22.000	21.996	18.824	0.8	1.3	85 500	113 000	8 750	11 500	3 200	4 300
	122.238	33.338	31.750	23.812	3.5	3.3	135 000	156 000	13 800	15 900	3 000	4 000
<b>60.325</b>	100.000	25.400	25.400	19.845	3.5	3.3	91 000	135 000	9 250	13 700	3 400	4 800
	101.600	25.400	25.400	19.845	3.5	3.3	91 000	135 000	9 250	13 700	3 400	4 800
	122.238	38.100	36.678	30.162	2.3	3.3	161 000	221 000	16 400	22 500	3 000	4 000
	122.238	38.100	38.354	29.718	8.0	1.5	188 000	245 000	19 200	25 000	3 000	4 000
	122.238	43.658	43.764	36.512	0.8	3.3	198 000	292 000	20 200	29 700	3 000	4 000
	127.000	44.450	44.450	34.925	3.5	3.3	199 000	258 000	20 200	26 300	3 000	4 000
	130.175	41.275	41.275	31.750	3.5	3.3	195 000	263 000	19 800	26 800	2 800	3 800
	135.755	53.975	56.007	44.450	3.5	3.3	264 000	355 000	27 000	36 000	2 800	3 800
<b>61.912</b>	136.525	46.038	46.038	36.512	3.5	3.3	233 000	370 000	23 800	37 500	2 600	3 400
	146.050	41.275	39.688	25.400	3.5	3.3	193 000	225 000	19 700	22 900	2 400	3 400
	152.400	47.625	46.038	31.750	3.5	3.3	237 000	267 000	24 200	27 300	2 400	3 400
<b>63.500</b>	94.458	19.050	19.050	15.083	1.5	1.5	59 000	100 000	6 050	10 200	3 600	4 800
	104.775	21.433	22.000	15.875	2.0	2.0	83 500	107 000	8 500	10 900	3 400	4 500
	107.950	25.400	25.400	19.050	1.5	3.3	90 000	138 000	9 150	14 100	3 200	4 300
	110.000	22.000	21.996	18.824	3.5	1.3	85 500	113 000	8 750	11 500	3 200	4 300
	110.000	22.000	21.996	18.824	1.5	1.3	85 500	113 000	8 750	11 500	3 200	4 300
	112.712	30.162	30.048	23.812	3.5	3.2	120 000	173 000	12 200	17 700	3 200	4 300
	112.712	30.162	30.162	23.812	3.5	3.3	142 000	202 000	14 500	20 600	3 200	4 300
	112.712	33.338	30.048	26.988	3.5	3.3	120 000	173 000	12 200	17 700	3 200	4 300
	122.238	38.100	38.354	29.718	7.0	3.3	188 000	245 000	19 200	25 000	3 000	4 000
	122.238	38.100	38.354	29.718	7.0	1.5	188 000	245 000	19 200	25 000	3 000	4 000
	122.238	38.100	38.354	29.718	3.5	1.5	188 000	245 000	19 200	25 000	3 000	4 000
	122.238	43.658	43.764	36.512	3.5	3.3	198 000	292 000	20 200	29 700	3 000	4 000
	123.825	38.100	36.678	30.162	3.5	3.3	161 000	221 000	16 400	22 500	3 000	4 000
	127.000	36.512	36.170	28.575	3.5	3.3	166 000	234 000	16 900	23 900	2 800	3 800
	130.175	41.275	41.275	31.750	3.5	3.3	195 000	263 000	19 800	26 800	2 800	3 800
	136.525	36.512	33.236	23.520	2.3	3.3	152 000	183 000	15 500	18 700	2 600	3 600
	136.525	41.275	41.275	31.750	3.5	3.3	195 000	263 000	19 800	26 800	2 800	3 800
	140.030	36.512	33.236	23.520	2.3	2.3	152 000	183 000	15 500	18 700	2 600	3 600
<b>64.963</b>	127.000	36.512	36.170	28.575	3.5	3.3	166 000	234 000	16 900	23 900	2 800	3 800

Bearing Numbers		Abutment and Fillet Dimensions (mm)				Eff. Load Centers (mm)	Constant	Axial Load Factors		Mass (kg)	
CONE	CUP	$d_a$	$d_b$	$D_a$	$D_b$	$a$	$e$	$Y_1$	$Y_0$	approx CONE	CUP
<b>▲ JLM 508748</b>	<b>▲ JLM 508710</b>	75	66	85	91	5	2.5	21.6	0.40	1.5	0.82
<b>* 39236</b>	<b>39412</b>	71	67	96	100	2.3	2	20.0	0.39	1.5	0.85
<b>397</b>	<b>394 A</b>	69	68	101	104	0.8	1.3	20.9	0.40	1.5	0.82
<b>66585</b>	<b>66520</b>	79	73	105	116	3.5	3.3	34.3	0.67	0.90	0.50
<b>28985</b>	<b>28921</b>	73	67	89	96	3.5	3.3	22.9	0.43	1.4	0.78
<b>28985</b>	<b>28920</b>	73	67	90	97	3.5	3.3	22.9	0.43	1.4	0.78
<b>558</b>	<b>553 X</b>	73	69	108	115	2.3	3.3	28.8	0.35	1.7	0.95
<b>HM 212044</b>	<b>HM 212010</b>	85	70	110	116	8	1.5	27.0	0.34	1.8	0.98
<b>5582</b>	<b>5535</b>	73	72	106	116	0.8	3.3	29.9	0.36	1.7	0.92
<b>65237</b>	<b>65500</b>	82	71	107	119	3.5	3.3	35.0	0.49	1.2	0.68
<b>637</b>	<b>633</b>	78	72	116	124	3.5	3.3	29.9	0.36	1.7	0.91
<b>6376</b>	<b>6320</b>	81	74	117	126	3.5	3.3	35.0	0.32	1.8	1.0
<b>H 715334</b>	<b>H 715311</b>	84	78	119	132	3.5	3.3	37.1	0.47	1.3	0.70
<b>H 913842</b>	<b>H 913810</b>	90	82	124	138	3.5	3.3	44.4	0.78	0.77	0.42
<b>9180</b>	<b>9121</b>	90	81	130	145	3.5	3.3	44.3	0.66	0.92	0.50
<b>L 610549</b>	<b>L 610510</b>	71	69	86	91	1.5	1.5	19.6	0.42	1.4	0.78
<b>39250</b>	<b>39412</b>	73	69	96	100	2	2	20.0	0.39	1.5	0.85
<b>29586</b>	<b>29520</b>	73	71	96	103	1.5	3.3	24.0	0.46	1.3	0.72
<b>395</b>	<b>394 A</b>	77	70	101	104	3.5	1.3	20.9	0.40	1.5	0.82
<b>390 A</b>	<b>394 A</b>	73	70	101	104	1.5	1.3	20.9	0.40	1.5	0.82
<b>3982</b>	<b>3920</b>	77	71	99	106	3.5	3.2	25.5	0.40	1.5	0.82
<b>39585</b>	<b>39520</b>	77	71	101	107	3.5	3.3	23.5	0.34	1.8	0.97
<b>3982</b>	<b>3926</b>	78	71	98	106	3.5	3.3	28.7	0.40	1.5	0.82
<b>HM 212047</b>	<b>HM 212011</b>	87	73	108	116	7	3.3	26.9	0.34	1.8	0.98
<b>HM 212047</b>	<b>HM 212010</b>	87	73	110	116	7	1.5	26.9	0.34	1.8	0.98
<b>HM 212046</b>	<b>HM 212010</b>	80	73	110	116	3.5	1.5	26.9	0.34	1.8	0.98
<b>5584</b>	<b>5535</b>	81	75	106	116	3.5	3.3	29.9	0.36	1.7	0.92
<b>559</b>	<b>522 A</b>	78	73	109	116	3.5	3.3	28.8	0.35	1.7	0.95
<b>565</b>	<b>563</b>	80	73	112	120	3.5	3.3	28.3	0.36	1.6	0.91
<b>639</b>	<b>633</b>	81	74	116	124	3.5	3.3	29.9	0.36	1.7	0.91
<b>78250</b>	<b>78537</b>	85	79	115	130	2.3	3.3	44.2	0.87	0.69	0.38
<b>639</b>	<b>632</b>	79	76	119	125	3.5	3.3	29.9	0.36	1.7	0.91
<b>78250</b>	<b>78551</b>	85	79	117	132	2.3	2.3	44.2	0.87	0.69	0.38
<b>569</b>	<b>563</b>	81	74	112	120	3.5	3.3	28.3	0.36	1.6	0.91

Notes \* The maximum bore diameter is listed and its tolerance is negative (See Table 8.4.1 on Page A68).

▲ The tolerances are listed in Tables 2, 3 and 4 on Pages B109 and B110.

# SINGLE-ROW TAPERED ROLLER BEARINGS (INCH DESIGN)

Bore Diameter 65.000~69.850 mm

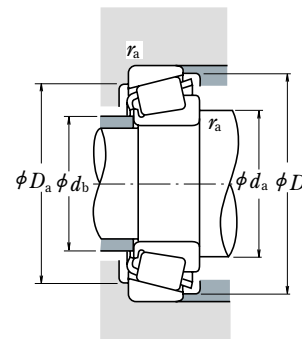
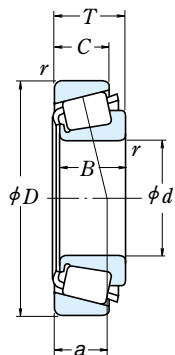

### Dynamic Equivalent Load

$$P = X F_r + Y F_a$$

$F_a / F_r \leq e$		$F_a / F_r > e$	
X	Y	X	Y
1	0	0.4	$Y_1$

### Static Equivalent Load

$P_0 = 0.5 F_r + Y_0 F_a$   
 When  $F_r > 0.5 F_r + Y_0 F_a$ , use  $P_0 = F_r$   
 The values of  $e$ ,  $Y_1$ , and  $Y_0$  are given in the table below.

Boundary Dimensions (mm)					Basic Load Ratings (N)				Limiting Speeds (rpm)				
$d$	$D$	$T$	$B$	$C$	Cone $r$	Cup $r$	$C_r$	$C_{0r}$	$C_r$	$C_{0r}$	Grease	Oil	
<b>65.000</b>	105.000	24.000	23.000	18.500	3.0	1.0	93 000	126 000	9 500	12 900	3 400	4 500	
	110.000	28.000	28.000	22.500	3.0	2.5	120 000	173 000	12 200	17 700	3 200	4 300	
	120.000	29.002	29.007	23.444	2.3	3.3	123 000	169 000	12 500	17 200	3 000	4 000	
	120.000	39.000	38.500	32.000	3.0	2.5	185 000	249 000	18 800	25 400	3 000	4 000	
<b>65.088</b>	135.755	53.975	56.007	44.450	3.5	3.3	264 000	355 000	27 000	36 000	2 800	3 800	
	136.525	46.038	46.038	36.512	3.5	3.3	233 000	370 000	23 800	37 500	2 600	3 400	
<b>66.675</b>	110.000	22.000	21.996	18.824	0.8	1.3	85 500	113 000	8 750	11 500	3 200	4 300	
	110.000	22.000	21.996	18.824	3.5	1.3	85 500	113 000	8 750	11 500	3 200	4 300	
	112.712	30.162	30.048	23.812	3.5	3.2	120 000	173 000	12 200	17 700	3 200	4 300	
	112.712	30.162	30.048	23.812	5.5	3.2	120 000	173 000	12 200	17 700	3 200	4 300	
	112.712	30.162	30.162	23.812	3.5	0.8	142 000	202 000	14 500	20 600	3 200	4 300	
	112.712	30.162	30.162	23.812	3.5	3.3	142 000	202 000	14 500	20 600	3 200	4 300	
	117.475	30.162	30.162	23.812	3.5	3.3	119 000	179 000	12 200	18 300	3 000	4 000	
	122.238	38.100	36.678	30.162	3.5	3.3	161 000	221 000	16 400	22 500	3 000	4 000	
	122.238	38.100	38.354	29.718	3.5	1.5	188 000	245 000	19 200	25 000	3 000	4 000	
	122.238	38.100	38.354	29.718	3.5	3.3	188 000	245 000	19 200	25 000	3 000	4 000	
	123.825	38.100	36.678	30.162	3.5	3.3	161 000	221 000	16 400	22 500	3 000	4 000	
	136.525	46.038	46.038	36.512	3.5	3.3	233 000	370 000	23 800	37 500	2 600	3 400	
	<b>68.262</b>	110.000	22.000	21.996	18.824	2.3	1.3	85 500	113 000	8 750	11 500	3 200	4 300
		120.000	29.795	29.007	24.237	3.5	2.0	123 000	169 000	12 500	17 200	3 000	4 000
122.238		38.100	36.678	30.162	3.5	3.3	161 000	221 000	16 400	22 500	3 000	4 000	
127.000		36.512	36.170	28.575	3.5	3.3	166 000	234 000	16 900	23 900	2 800	3 800	
136.525		41.275	41.275	31.750	3.5	3.3	229 000	297 000	23 300	30 500	2 600	3 600	
136.525		46.038	46.038	36.512	3.5	3.3	233 000	370 000	23 800	37 500	2 600	3 400	
152.400		47.625	46.038	31.750	3.5	3.3	237 000	267 000	24 200	27 300	2 400	3 400	
<b>69.850</b>		112.712	22.225	21.996	15.875	1.5	0.8	85 000	113 000	8 650	11 500	3 000	4 000
		112.712	25.400	25.400	19.050	1.5	3.3	96 000	152 000	9 800	15 500	2 800	4 000
		117.475	30.162	30.162	23.812	3.5	3.3	119 000	179 000	12 200	18 300	3 000	4 000
	120.000	32.545	32.545	26.195	3.5	3.3	152 000	225 000	15 500	22 900	3 000	4 000	
	120.650	25.400	25.400	19.050	1.5	3.3	96 000	152 000	9 800	15 500	2 800	4 000	
	127.000	36.512	36.170	28.575	3.5	0.8	166 000	234 000	16 900	23 900	2 800	3 800	
	130.175	41.275	41.275	31.750	3.5	3.3	195 000	263 000	19 800	26 800	2 800	3 800	
	146.050	41.275	39.688	25.400	3.5	3.3	193 000	225 000	19 700	22 900	2 400	3 400	
	146.050	41.275	41.275	31.750	3.5	3.3	207 000	296 000	21 100	30 000	2 400	3 200	
	149.225	53.975	54.229	44.450	5.0	3.3	287 000	410 000	29 300	41 500	2 600	3 400	
	150.089	44.450	46.672	36.512	3.5	3.3	265 000	370 000	27 000	37 500	2 400	3 200	

Bearing Numbers		Abutment and Fillet Dimensions (mm)				Eff. Load Centers (mm)	Constant	Axial Load Factors		Mass (kg)	
CONE	CUP	$d_a$	$d_b$	$D_a$	$D_b$	$a$	$e$	$Y_1$	$Y_0$	approx CONE	CUP
<b>▲ JLM 710949</b>	<b>▲ JLM 710910</b>	77	71	96	101	3	1	23.7	0.45	1.3	0.73
<b>▲ JM 511946</b>	<b>▲ JM 511910</b>	78	72	99	105	3	2.5	24.5	0.40	1.5	0.82
<b>478</b>	<b>472 A</b>	77	73	106	114	2.3	3.3	24.3	0.38	1.6	0.86
<b>▲ JH 211749</b>	<b>▲ JH 211710</b>	80	74	107	114	3	2.5	27.9	0.34	1.8	0.98
<b>6379</b>	<b>6320</b>	84	77	117	126	3.5	3.3	35.0	0.32	1.8	1.0
<b>H 715340</b>	<b>H 715311</b>	88	82	118	132	3.5	3.3	37.1	0.47	1.3	0.70
<b>395 A</b>	<b>394 A</b>	73	73	101	104	0.8	1.3	20.9	0.40	1.5	0.82
<b>395 S</b>	<b>394 A</b>	79	73	101	104	3.5	1.3	20.9	0.40	1.5	0.82
<b>3984</b>	<b>3920</b>	80	74	99	106	3.5	3.2	25.5	0.40	1.5	0.82
<b>3994</b>	<b>3920</b>	84	74	99	106	5.5	3.2	25.5	0.40	1.5	0.82
<b>39590</b>	<b>39521</b>	80	74	103	107	3.5	0.8	23.5	0.34	1.8	0.97
<b>39590</b>	<b>39520</b>	80	74	101	107	3.5	3.3	23.5	0.34	1.8	0.97
<b>33262</b>	<b>33462</b>	81	75	104	112	3.5	3.3	26.8	0.44	1.4	0.76
<b>560</b>	<b>553 X</b>	81	75	108	115	3.5	3.3	28.8	0.35	1.7	0.95
<b>HM 212049</b>	<b>HM 212010</b>	82	75	110	116	3.5	1.5	26.9	0.34	1.8	0.98
<b>HM 212049</b>	<b>HM 212011</b>	81	74	108	116	3.5	3.3	26.9	0.34	1.8	0.98
<b>560</b>	<b>552 A</b>	81	75	109	116	3.5	3.3	28.8	0.35	1.7	0.95
<b>H 715341</b>	<b>H 715311</b>	89	83	118	132	3.5	3.3	37.1	0.47	1.3	0.70
<b>399 A</b>	<b>394 A</b>	78	74	101	104	2.3	1.3	20.9	0.40	1.5	0.82
<b>480</b>	<b>472</b>	83	76	106	113	3.5	2	25.1	0.38	1.6	0.86
<b>560 S</b>	<b>553 X</b>	83	76	108	115	3.5	3.3	28.8	0.35	1.7	0.95
<b>570</b>	<b>563</b>	83	77	112	120	3.5	3.3	28.3	0.36	1.6	0.91
<b>H 414245</b>	<b>H 414210</b>	86	82	121	129	3.5	3.3	30.6	0.36	1.7	0.92
<b>H 715343</b>	<b>H 715311</b>	90	84	118	132	3.5	3.3	37.1	0.47	1.3	0.70
<b>9185</b>	<b>9121</b>	94	81	130	145	3.5	3.3	44.3	0.66	0.92	0.50
<b>LM 613449</b>	<b>LM 613410</b>	78	76	104	107	1.5	0.8	22.1	0.42	1.4	0.79
<b>29675</b>	<b>29620</b>	80	77	101	109	1.5	3.3	26.3	0.49	1.2	0.68
<b>33275</b>	<b>33462</b>	84	77	104	112	3.5	3.3	26.8	0.44	1.4	0.76
<b>47487</b>	<b>47420</b>	84	78	107	114	3.5	3.3	26.0	0.36	1.7	0.92
<b>29675</b>	<b>29630</b>	79	78	105	113	1.5	3.3	26.3	0.49	1.2	0.68
<b>566</b>	<b>563 X</b>	85	78	114	120	3.5	0.8	28.3	0.36	1.6	0.91
<b>643</b>	<b>633</b>	86	80	116	124	3.5	3.3	29.9	0.36	1.7	0.91
<b>H 913849</b>	<b>H 913810</b>	95	82	124	138	3.5	3.3	44.4	0.78	0.77	0.42
<b>655</b>	<b>653</b>	88	82	131	139	3.5	3.3	33.2	0.41	1.5	0.81
<b>6454</b>	<b>6420</b>	94	85	129	140	5	3.3	39.0	0.36	1.7	0.91
<b>745 A</b>	<b>742</b>	88	82	134	142	3.5	3.3	32.5	0.33	1.8	1.0

Note ▲ The tolerances are listed in Tables 2, 3 and 4 on Pages B109 and B110.



# SINGLE-ROW TAPERED ROLLER BEARINGS (INCH DESIGN)

Bore Diameter 70.000~76.200 mm

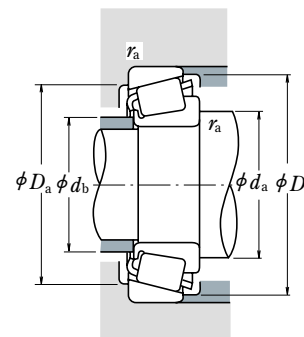
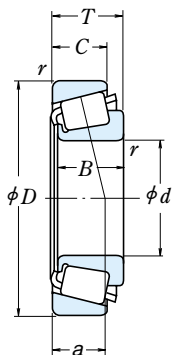

### Dynamic Equivalent Load

$$P = X F_r + Y F_a$$

$F_a / F_r \leq e$		$F_a / F_r > e$	
X	Y	X	Y
1	0	0.4	$Y_1$

### Static Equivalent Load

$P_0 = 0.5 F_r + Y_0 F_a$   
 When  $F_r > 0.5 F_r + Y_0 F_a$ , use  $P_0 = F_r$   
 The values of  $e$ ,  $Y_1$ , and  $Y_0$  are given in the table below.

d	Boundary Dimensions (mm)					Cone r min	Cup r max	Basic Load Ratings (N) (kgf)				Limiting Speeds (rpm)	
	D	T	B	C	$C_r$			$C_{0r}$	$C_r$	$C_{0r}$	Grease	Oil	
70.000	110.000	26.000	25.000	20.500	1.0	2.5	98 500	152 000	10 000	15 500	3 000	4 000	
	115.000	29.000	29.000	23.000	3.0	2.5	126 000	177 000	12 900	18 100	3 000	4 000	
	120.000	29.795	29.007	24.237	2.0	2.0	123 000	169 000	12 500	17 200	3 000	4 000	
71.438	117.475	30.162	30.162	23.812	3.5	3.3	119 000	179 000	12 200	18 300	3 000	4 000	
	120.000	32.545	32.545	26.195	3.5	3.3	152 000	225 000	15 500	22 900	3 000	4 000	
	127.000	36.512	36.170	28.575	6.4	3.3	166 000	234 000	16 900	23 900	2 800	3 800	
	127.000	36.512	36.170	28.575	3.5	3.3	166 000	234 000	16 900	23 900	2 800	3 800	
	130.175	41.275	41.275	31.750	6.4	3.3	195 000	263 000	19 800	26 800	2 800	3 800	
	136.525	41.275	41.275	31.750	3.5	3.3	195 000	263 000	19 800	26 800	2 800	3 800	
	136.525	41.275	41.275	31.750	3.5	3.3	229 000	297 000	23 300	30 500	2 600	3 600	
	136.525	46.038	46.038	36.512	3.5	3.3	233 000	370 000	23 800	37 500	2 600	3 400	
	73.025	112.712	25.400	25.400	19.050	3.5	3.3	96 000	152 000	9 800	15 500	2 800	4 000
		117.475	30.162	30.162	23.812	3.5	3.3	119 000	179 000	12 200	18 300	3 000	4 000
127.000		36.512	36.170	28.575	3.5	3.3	166 000	234 000	16 900	23 900	2 800	3 800	
73.817	146.050	41.275	41.275	31.750	3.5	3.3	207 000	296 000	21 100	30 000	2 400	3 200	
	149.225	53.975	54.229	44.450	3.5	3.3	287 000	410 000	29 300	41 500	2 600	3 400	
74.612	127.000	36.512	36.170	28.575	0.8	3.3	166 000	234 000	16 900	23 900	2 800	3 800	
	150.000	41.275	41.275	31.750	3.5	3.0	207 000	296 000	21 100	30 000	2 400	3 200	
75.000	115.000	25.000	25.000	19.000	3.0	2.5	101 000	150 000	10 300	15 300	3 000	4 000	
	120.000	31.000	29.500	25.000	3.0	2.5	129 000	198 000	13 100	20 200	2 800	3 800	
	145.000	51.000	51.000	42.000	3.0	2.5	287 000	410 000	29 300	41 500	2 600	3 400	
76.200	121.442	24.608	23.012	17.462	2.0	2.0	89 000	124 000	9 100	12 600	2 800	3 800	
	127.000	30.162	31.000	22.225	3.5	3.3	134 000	195 000	13 700	19 900	2 800	3 800	
	127.000	30.162	31.001	22.225	6.4	3.3	134 000	195 000	13 700	19 900	2 800	3 800	
	133.350	33.338	33.338	26.195	0.8	3.3	154 000	237 000	15 700	24 200	2 600	3 600	
	135.732	44.450	46.101	34.925	3.5	3.3	216 000	340 000	22 000	35 000	2 600	3 600	
	136.525	30.162	29.769	22.225	3.5	3.3	130 000	192 000	13 300	19 600	2 600	3 400	
	136.525	30.162	29.769	22.225	6.4	3.3	130 000	192 000	13 300	19 600	2 600	3 400	
	139.992	36.512	36.098	28.575	3.5	3.3	175 000	260 000	17 800	26 500	2 600	3 400	
	149.225	53.975	54.229	44.450	3.5	3.3	287 000	410 000	29 300	41 500	2 600	3 400	
	152.400	39.688	36.322	30.162	3.5	3.2	183 000	285 000	18 700	29 100	2 200	3 200	
	152.400	41.275	41.275	31.750	3.5	3.3	207 000	296 000	21 100	30 000	2 400	3 200	
	161.925	49.212	46.038	31.750	3.5	3.3	248 000	290 000	25 300	29 600	2 200	3 000	
	161.925	53.975	55.100	42.862	3.5	3.3	325 000	480 000	33 000	49 000	2 200	3 000	
	161.925	53.975	55.100	42.862	6.4	3.3	325 000	480 000	33 000	49 000	2 200	3 000	
	161.925	53.975	55.100	42.862	6.4	0.8	325 000	480 000	33 000	49 000	2 200	3 000	

Bearing Numbers		Abutment and Fillet Dimensions (mm)				Cone r max	Cup r max	Eff. Load Centers (mm) a	Constant e	Axial Load Factors		Mass (kg)	
CONE	CUP	da	db	Da	Db					Y1	Y0	approx CONE	CUP
▲ JLM 813049	▲ JLM 813010	78	77	98	105	1	2.5	26.2	0.49	1.2	0.68	0.604	0.304
▲ JM 612949	▲ JM 612910	83	77	103	110	3	2.5	26.4	0.43	1.4	0.77	0.800	0.362
484	472	80	78	106	113	2	2	25.1	0.38	1.6	0.86	0.822	0.493
33281	33462	85	79	104	112	3.5	3.3	26.8	0.44	1.4	0.76	0.789	0.442
47490	47420	86	79	107	114	3.5	3.3	26.0	0.36	1.7	0.92	0.983	0.477
567 S	563	92	80	112	120	6.4	3.3	28.3	0.36	1.6	0.91	1.21	0.655
567 A	563	86	80	112	120	3.5	3.3	28.3	0.36	1.6	0.91	1.23	0.655
645	633	93	81	116	124	6.4	3.3	29.9	0.36	1.7	0.91	1.49	0.712
644	632	87	81	118	125	3.5	3.3	29.9	0.36	1.7	0.91	1.5	1.04
H 414249	H 414210	89	83	121	129	3.5	3.3	30.6	0.36	1.7	0.92	1.83	0.796
H 715345	H 715311	92	84	119	132	3.5	3.3	37.1	0.47	1.3	0.70	2.15	0.961
29685	29620	86	80	101	109	3.5	3.3	26.3	0.49	1.2	0.68	0.62	0.273
33287	33462	87	80	104	112	3.5	3.3	26.8	0.44	1.4	0.76	0.746	0.442
567	563	88	81	112	120	3.5	3.3	28.3	0.36	1.6	0.91	1.17	0.655
657	653	91	85	131	139	3.5	3.3	33.2	0.41	1.5	0.81	2.24	0.891
6460	6420	93	87	129	140	3.5	3.3	39.0	0.36	1.7	0.91	2.8	1.63
568	563	83	82	112	120	0.8	3.3	28.3	0.36	1.6	0.91	1.15	0.655
658	653 X	92	86	133	141	3.5	3	33.2	0.41	1.5	0.81	2.37	0.932
▲ JLM 714149	▲ JLM 714110	87	81	104	110	3	2.5	25.3	0.46	1.3	0.72	0.638	0.272
▲ JM 714249	▲ JM 714210	88	83	108	115	3	2.5	28.8	0.44	1.4	0.74	0.863	0.436
▲ JH 415647	▲ JH 415610	94	89	129	139	3	2.5	36.7	0.36	1.7	0.91	2.64	1.19
34300	34478	86	84	111	116	2	2	26.3	0.45	1.3	0.73	0.65	0.316
42687	42620	90	84	114	121	3.5	3.3	27.3	0.42	1.4	0.79	1.03	0.438
42688	42620	94	84	114	121	6.4	3.3	27.3	0.42	1.4	0.79	1.01	0.438
47680	47620	86	85	119	128	0.8	3.3	29.0	0.40	1.5	0.82	1.39	0.577
5760	5735	94	88	119	130	3.5	3.3	32.9	0.41	1.5	0.81	1.86	0.887
495 A	493	92	86	122	130	3.5	3.3	28.7	0.44	1.4	0.74	1.27	0.55
495 AX	493	98	86	122	130	6.4	3.3	28.7	0.44	1.4	0.74	1.26	0.55
575	572	92	86	125	133	3.5	3.3	31.1	0.40	1.5	0.82	1.61	0.788
6461	6420	96	89	129	140	3.5	3.3	39.0	0.36	1.7	0.91	2.64	1.63
590 A	592 A	95	89	135	145	3.5	3.2	37.1	0.44	1.4	0.75	2.2	1.06
659	652	93	87	134	141	3.5	3.3	33.2	0.41	1.5	0.81	2.11	1.26
9285	9220	103	90	138	153	3.5	3.3	49.8	0.71	0.85	0.47	2.82	1.4
6576	6535	99	92	141	154	3.5	3.3	40.7	0.40	1.5	0.82	3.74	1.67
6575	6535	104	92	141	154	6.4	3.3	40.7	0.40	1.5	0.82	3.73	1.67
6575	6536	104	92	144	154	6.4	0.8	40.7	0.40	1.5	0.82	3.73	1.68

Note ▲ The tolerances are listed in Tables 2, 3 and 4 on Pages B109 and B110.

# SINGLE-ROW TAPERED ROLLER BEARINGS (INCH DESIGN)

Bore Diameter 76.200~83.345 mm

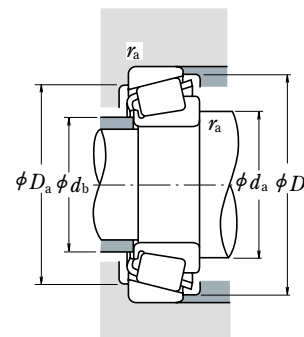
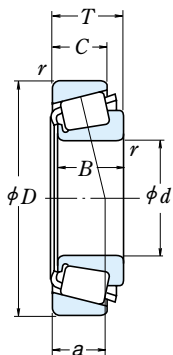

### Dynamic Equivalent Load

$$P = X F_r + Y F_a$$

$F_a / F_r \leq e$		$F_a / F_r > e$	
X	Y	X	Y
1	0	0.4	$Y_1$

### Static Equivalent Load

$P_0 = 0.5 F_r + Y_0 F_a$   
 When  $F_r > 0.5 F_r + Y_0 F_a$ , use  $P_0 = F_r$   
 The values of  $e$ ,  $Y_1$ , and  $Y_0$  are given in the table below.

d	Boundary Dimensions (mm)					Cone r min	Cup	Basic Load Ratings (N) (kgf)				Limiting Speeds (rpm)	
	D	T	B	C	$C_r$			$C_{0r}$	$C_r$	$C_{0r}$	Grease	Oil	
<b>76.200</b>	168.275	53.975	56.363	41.275	6.4	3.3	345 000	470 000	35 000	48 000	2 200	3 000	
	168.275	53.975	56.363	41.275	0.8	3.3	345 000	470 000	35 000	48 000	2 200	3 000	
	171.450	49.212	46.038	31.750	3.5	3.3	257 000	310 000	26 200	32 000	2 000	2 800	
	177.800	55.562	50.800	34.925	3.5	3.3	257 000	310 000	26 200	32 000	2 000	2 800	
<b>77.788</b>	121.442	24.608	23.012	17.462	3.5	2.0	89 000	124 000	9 100	12 600	2 800	3 800	
	127.000	30.162	31.000	22.225	3.5	3.3	134 000	195 000	13 700	19 900	2 800	3 800	
	135.733	44.450	46.101	34.925	3.5	3.3	216 000	340 000	22 000	35 000	2 600	3 600	
	146.050	41.275	41.275	31.750	3.5	3.3	207 000	296 000	21 100	30 000	2 400	3 200	
<b>79.375</b>	150.089	44.450	46.672	36.512	3.5	3.3	265 000	370 000	27 000	37 500	2 400	3 200	
	130.000	35.000	34.000	28.500	3.0	2.5	166 000	251 000	17 000	25 600	2 600	3 600	
<b>80.962</b>	136.525	30.162	29.769	22.225	3.5	3.3	130 000	192 000	13 300	19 600	2 600	3 400	
	139.700	36.512	36.098	28.575	3.5	3.3	175 000	260 000	17 800	26 500	2 600	3 400	
	139.992	36.512	36.098	28.575	3.5	3.3	175 000	260 000	17 800	26 500	2 600	3 400	
	125.412	25.400	25.400	19.845	3.5	1.5	102 000	164 000	10 400	16 700	2 600	3 600	
<b>82.550</b>	133.350	30.162	29.769	22.225	3.5	3.3	130 000	192 000	13 300	19 600	2 600	3 400	
	133.350	33.338	33.338	26.195	0.8	3.3	154 000	237 000	15 700	24 200	2 600	3 600	
	133.350	33.338	33.338	26.195	6.8	3.3	154 000	237 000	15 700	24 200	2 600	3 600	
	133.350	39.688	39.688	32.545	6.8	3.3	179 000	310 000	18 300	31 500	2 600	3 600	
	136.525	30.162	29.769	22.225	3.5	3.3	130 000	192 000	13 300	19 600	2 600	3 400	
	139.700	36.512	36.098	28.575	3.5	3.3	175 000	260 000	17 800	26 500	2 600	3 400	
	139.992	36.512	36.098	28.575	3.5	3.3	175 000	260 000	17 800	26 500	2 600	3 400	
	139.992	36.512	36.098	28.575	6.8	3.3	175 000	260 000	17 800	26 500	2 600	3 400	
	146.050	41.275	41.275	31.750	3.5	3.3	207 000	296 000	21 100	30 000	2 400	3 200	
	150.000	44.455	46.672	35.000	3.5	3.3	265 000	370 000	27 000	37 500	2 400	3 200	
	150.089	44.450	46.672	36.512	3.5	3.3	265 000	370 000	27 000	37 500	2 400	3 200	
	152.400	41.275	41.275	31.750	3.5	3.3	207 000	296 000	21 100	30 000	2 400	3 200	
	161.925	47.625	48.260	38.100	3.5	3.3	274 000	390 000	28 000	40 000	2 200	3 000	
	161.925	53.975	55.100	42.862	3.5	3.3	325 000	480 000	33 000	49 000	2 200	3 000	
	168.275	47.625	48.260	38.100	3.5	3.3	274 000	390 000	28 000	40 000	2 200	3 000	
	168.275	53.975	56.363	41.275	3.5	3.3	345 000	470 000	35 000	48 000	2 200	3 000	
<b>83.345</b>	125.412	25.400	25.400	19.845	3.5	1.5	102 000	164 000	10 400	16 700	2 600	3 600	
	125.412	25.400	25.400	19.845	0.8	1.5	102 000	164 000	10 400	16 700	2 600	3 600	

Bearing Numbers		Abutment and Fillet Dimensions (mm)					Eff. Load Centers (mm) a	Constant e	Axial Load Factors		Mass (kg)		
CONE	CUP	$d_a$	$d_b$	$D_a$	$D_b$	Cone $r_a$ max			Cup	$Y_1$	$Y_0$	approx CONE	CUP
<b>843</b>	<b>832</b>	101	89	149	155	6.4	3.3	35.2	0.30	2.0	1.1	4.11	1.74
<b>837</b>	<b>832</b>	90	89	149	155	0.8	3.3	35.2	0.30	2.0	1.1	4.13	1.74
<b>9380</b>	<b>9321</b>	105	98	147	164	3.5	3.3	54.1	0.76	0.79	0.43	3.47	1.51
<b>9378</b>	<b>9320</b>	105	98	148	164	3.5	3.3	57.3	0.76	0.79	0.43	3.71	2.24
<b>34306</b>	<b>34478</b>	90	84	110	116	3.5	2	26.3	0.45	1.3	0.73	0.612	0.316
<b>42690</b>	<b>42620</b>	91	85	114	121	3.5	3.3	27.3	0.42	1.4	0.79	0.976	0.438
<b>5795</b>	<b>5735</b>	96	89	119	130	3.5	3.3	32.9	0.41	1.5	0.81	1.79	0.887
<b>661</b>	<b>653</b>	96	90	131	139	3.5	3.3	33.2	0.41	1.5	0.81	1.99	0.891
<b>750</b>	<b>742</b>	96	90	134	142	3.5	3.3	32.5	0.33	1.8	1.0	2.42	1.07
<b>▲ JM 515649</b>	<b>▲ JM 515610</b>	94	88	117	125	3	2.5	29.9	0.39	1.5	0.85	1.18	0.583
<b>496</b>	<b>493</b>	95	89	122	130	3.5	3.3	28.7	0.44	1.4	0.74	1.13	0.55
<b>581</b>	<b>572 X</b>	96	90	125	133	3.5	3.3	31.1	0.40	1.5	0.82	1.44	0.774
<b>581</b>	<b>572</b>	96	90	125	133	3.5	3.3	31.1	0.40	1.5	0.82	1.44	0.788
<b>27687</b>	<b>27620</b>	96	89	115	120	3.5	1.5	25.7	0.42	1.4	0.79	0.747	0.348
<b>495</b>	<b>492 A</b>	97	90	120	128	3.5	3.3	28.7	0.44	1.4	0.74	1.08	0.434
<b>47686</b>	<b>47620</b>	97	90	119	128	3.5	3.3	29.0	0.40	1.5	0.82	1.18	0.577
<b>47685</b>	<b>47620</b>	90	90	119	128	0.8	3.3	29.0	0.40	1.5	0.82	1.18	0.577
<b>47687</b>	<b>47620</b>	103	90	119	128	6.8	3.3	29.0	0.40	1.5	0.82	1.16	0.577
<b>HM 516448</b>	<b>HM 516410</b>	105	92	118	128	6.8	3.3	32.4	0.40	1.5	0.82	1.35	0.767
<b>495</b>	<b>493</b>	97	90	122	130	3.5	3.3	28.7	0.44	1.4	0.74	1.08	0.55
<b>580</b>	<b>572 X</b>	98	91	125	133	3.5	3.3	31.1	0.40	1.5	0.82	1.39	0.774
<b>580</b>	<b>572</b>	98	91	125	133	3.5	3.3	31.1	0.40	1.5	0.82	1.39	0.788
<b>582</b>	<b>572</b>	104	91	125	133	6.8	3.3	31.1	0.40	1.5	0.82	1.37	0.788
<b>663</b>	<b>653</b>	99	92	131	139	3.5	3.3	33.2	0.41	1.5	0.81	1.85	0.891
<b>749 A</b>	<b>743</b>	99	93	134	142	3.5	3.3	32.5	0.33	1.8	1.0	2.26	1.04
<b>749 A</b>	<b>742</b>	98	93	135	143	3.5	3.3	32.5	0.33	1.8	1.0	2.26	1.07
<b>663</b>	<b>652</b>	99	92	134	141	3.5	3.3	33.2	0.41	1.5	0.81	1.85	1.26
<b>757</b>	<b>752</b>	100	94	144	150	3.5	3.3	35.6	0.34	1.8	0.97	2.79	1.61
<b>6559</b>	<b>6535</b>	104	98	141	154	3.5	3.3	40.7	0.40	1.5	0.82	3.4	1.67
<b>757</b>	<b>753</b>	100	94	147	150	3.5	3.3	35.6	0.34	1.8	0.97	2.79	2.1
<b>842</b>	<b>832</b>	101	94	149	155	3.5	3.3	35.2	0.30	2.0	1.1	3.76	1.74
<b>27690</b>	<b>27620</b>	96	90	115	120	3.5	1.5	25.7	0.42	1.4	0.79	0.727	0.348
<b>27689</b>	<b>27620</b>	90	90	115	120	0.8	1.5	25.7	0.42	1.4	0.79	0.732	0.348

Note ▲ The tolerances are listed in Tables 2, 3 and 4 on Pages B109 and B110.

# SINGLE-ROW TAPERED ROLLER BEARINGS (INCH DESIGN)

Bore Diameter 84.138~90.488 mm

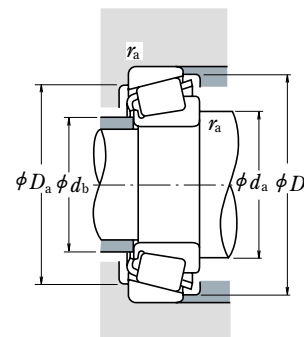
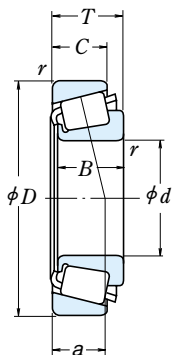

### Dynamic Equivalent Load

$$P = XF_r + YF_a$$

$F_a/F_r \leq e$		$F_a/F_r > e$	
X	Y	X	Y
1	0	0.4	$Y_1$

### Static Equivalent Load

$P_0 = 0.5F_r + Y_0F_a$   
 When  $F_r > 0.5F_r + Y_0F_a$ , use  $P_0 = F_r$   
 The values of  $e$ ,  $Y_1$ , and  $Y_0$  are given in the table below.

Boundary Dimensions (mm)					Basic Load Ratings (N) (kgf)				Limiting Speeds (rpm)			
$d$	$D$	$T$	$B$	$C$	Cone $r$	Cup $r$	$C_r$	$C_{0r}$	$C_r$	$C_{0r}$	Grease	Oil
<b>84.138</b>	136.525	30.162	29.769	22.225	3.5	3.3	130 000	192 000	13 300	19 600	2 600	3 400
	146.050	41.275	41.275	31.750	3.5	3.3	207 000	296 000	21 100	30 000	2 400	3 200
	171.450	49.212	46.038	31.750	3.5	3.3	257 000	310 000	26 200	32 000	2 000	2 800
<b>85.000</b>	130.000	30.000	29.000	24.000	6.0	2.5	138 000	222 000	14 100	22 700	2 600	3 600
	130.000	30.000	29.000	24.000	3.0	2.5	138 000	222 000	14 100	22 700	2 600	3 600
	140.000	39.000	38.000	31.500	3.0	2.5	202 000	305 000	20 600	31 000	2 400	3 400
	150.000	46.000	46.000	38.000	3.0	2.5	275 000	390 000	28 000	40 000	2 400	3 200
<b>85.026</b>	150.089	44.450	46.672	36.512	3.5	3.3	265 000	370 000	27 000	37 500	2 400	3 200
	150.089	44.450	46.672	36.512	5.0	3.3	265 000	370 000	27 000	37 500	2 400	3 200
<b>85.725</b>	133.350	30.162	29.769	22.225	3.5	3.3	130 000	192 000	13 300	19 600	2 600	3 400
	136.525	30.162	29.769	22.225	3.5	3.3	130 000	192 000	13 300	19 600	2 600	3 400
	142.138	42.862	42.862	34.133	4.8	3.3	221 000	360 000	22 500	36 500	2 400	3 400
<b>87.312</b>	146.050	41.275	41.275	31.750	6.4	3.3	207 000	296 000	21 100	30 000	2 400	3 200
	146.050	41.275	41.275	31.750	3.5	3.3	207 000	296 000	21 100	30 000	2 400	3 200
	152.400	39.688	36.322	30.162	3.5	3.2	183 000	285 000	18 700	29 100	2 200	3 200
	161.925	47.625	48.260	38.100	3.5	3.3	274 000	390 000	28 000	40 000	2 200	3 000
	161.925	47.625	48.260	38.100	7.0	3.3	274 000	390 000	28 000	40 000	2 200	3 000
	161.925	53.975	55.100	42.862	3.5	3.3	325 000	480 000	33 000	49 000	2 200	3 000
<b>88.900</b>	168.275	47.625	48.260	38.100	3.5	3.3	274 000	390 000	28 000	40 000	2 200	3 000
	168.275	53.975	56.363	41.275	3.5	3.3	345 000	470 000	35 000	48 000	2 200	3 000
	190.500	57.150	57.531	44.450	8.0	3.3	355 000	500 000	36 000	51 000	1 900	2 600
	190.500	57.150	57.531	46.038	8.0	3.3	390 000	520 000	39 500	53 500	1 900	2 600
	145.000	35.000	34.000	27.000	3.0	2.5	190 000	285 000	19 400	29 000	2 400	3 200
	147.000	40.000	40.000	32.500	7.0	3.5	229 000	345 000	23 400	35 000	2 400	3 200
<b>90.000</b>	155.000	44.000	44.000	35.500	3.0	2.5	274 000	395 000	28 000	40 000	2 200	3 000
	155.000	44.000	44.000	35.500	3.0	2.5	274 000	395 000	28 000	40 000	2 200	3 000
<b>90.488</b>	161.925	47.625	48.260	38.100	3.5	3.3	274 000	390 000	28 000	40 000	2 200	3 000

Bearing Numbers		Abutment and Fillet Dimensions (mm)				Eff. Load Centers (mm)		Constant	Axial Load Factors		Mass (kg)		
CONE	CUP	$d_a$	$d_b$	$D_a$	$D_b$	Cone $r_a$	Cup $r_a$	$e$	$Y_1$	$Y_0$	approx CONE	CUP	
<b>498</b>	<b>493</b>	98	91	122	130	3.5	3.3	28.7	0.44	1.4	0.74	1.04	0.55
	<b>664</b>	99	93	131	139	3.5	3.3	33.2	0.41	1.5	0.81	1.79	0.891
	<b>9385</b>	111	98	147	164	3.5	3.3	54.1	0.76	0.79	0.43	3.11	1.51
<b>JM 716648</b>	<b>JM 716610</b>	104	92	117	125	6	2.5	29.5	0.44	1.4	0.74	0.931	0.461
	<b>JM 716649</b>	98	92	117	125	3	2.5	29.5	0.44	1.4	0.74	0.943	0.461
	<b>JHM 516849</b>	100	94	125	134	3	2.5	33.3	0.41	1.5	0.81	1.55	0.768
	<b>JH 217249</b>	101	95	134	142	3	2.5	33.9	0.33	1.8	0.99	2.29	1.09
<b>749</b>	<b>742</b>	101	95	134	142	3.5	3.3	32.5	0.33	1.8	1.0	2.14	1.07
	<b>749 S</b>	104	95	134	142	5	3.3	32.5	0.33	1.8	1.0	2.14	1.07
<b>497</b>	<b>492 A</b>	99	93	120	128	3.5	3.3	28.7	0.44	1.4	0.74	0.987	0.434
	<b>497</b>	99	93	122	130	3.5	3.3	28.7	0.44	1.4	0.74	0.987	0.55
	<b>HM 617049</b>	106	95	125	137	4.8	3.3	35.4	0.43	1.4	0.76	1.77	0.911
<b>665 A</b>	<b>653</b>	107	95	131	139	6.4	3.3	33.2	0.41	1.5	0.81	1.71	0.891
	<b>665</b>	102	95	131	139	3.5	3.3	33.2	0.41	1.5	0.81	1.72	0.891
	<b>596</b>	102	96	135	144	3.5	3.2	37.1	0.44	1.4	0.75	1.85	1.06
<b>758</b>	<b>752</b>	103	97	144	150	3.5	3.3	35.6	0.34	1.8	0.97	2.63	1.61
	<b>677</b>	105	99	149	160	3.5	3.3	38.3	0.47	1.3	0.70	2.91	1.24
<b>HH 221432</b>	<b>HH 221410</b>	118	103	171	179	8	3.3	42.3	0.33	1.8	0.99	5.51	2.24
	<b>42350</b>	104	98	134	143	3	3.3	34.9	0.49	1.2	0.67	1.39	0.711
	<b>593</b>	104	98	135	144	3.5	3.2	37.1	0.44	1.4	0.75	1.73	1.06
<b>HM 518445</b>	<b>HM 518410</b>	107	96	137	148	6.4	3.3	33.1	0.40	1.5	0.82	2.11	0.776
	<b>759</b>	106	99	144	150	3.5	3.3	35.6	0.34	1.8	0.97	2.47	1.61
<b>766</b>	<b>752</b>	113	99	144	150	7	3.3	35.6	0.34	1.8	0.97	2.45	1.61
	<b>6580</b>	109	102	141	154	3.5	3.3	40.7	0.40	1.5	0.82	3.03	1.67
	<b>759</b>	106	99	147	150	3.5	3.3	35.6	0.34	1.8	0.97	2.47	2.1
<b>850</b>	<b>832</b>	106	100	149	155	3.5	3.3	35.2	0.30	2.0	1.1	3.39	1.74
	<b>855</b>	118	103	170	174	8	3.3	41.8	0.33	1.8	0.99	4.99	2.55
<b>HH 221434</b>	<b>HH 221410</b>	120	105	171	179	8	3.3	42.3	0.33	1.8	0.99	5.41	2.24
<b>JM 718149</b>	<b>JM 718110</b>	105	99	131	139	3	2.5	33.0	0.44	1.4	0.74	1.49	0.66
	<b>*HM 218248</b>	111	98	133	141	7	3.5	30.8	0.33	1.8	0.99	1.77	0.796
	<b>JHM 318448</b>	106	100	140	148	3	2.5	34.1	0.34	1.7	0.96	2.32	1.01
<b>760</b>	<b>752</b>	107	101	144	150	3.5	3.3	35.6	0.34	1.8	0.97	2.38	1.61

- Notes**
- \* The maximum bore diameter is listed and its tolerance is negative (See Table 8.4.1 on Page A68).
  - \*\* The maximum outside diameter is listed and its tolerance is negative (See Table 8.4.2 on Pages A68 and A69).
  - ▲ The tolerances are listed in Tables 2, 3 and 4 on Pages B109 and B110.

# SINGLE-ROW TAPERED ROLLER BEARINGS (INCH DESIGN)

Bore Diameter 92.075~100.012 mm

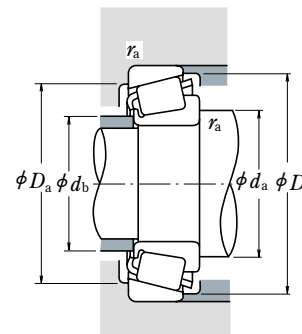
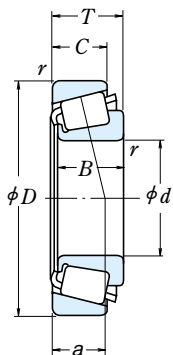

### Dynamic Equivalent Load

$$P = XF_r + YF_a$$

$F_a/F_r \leq e$		$F_a/F_r > e$	
X	Y	X	Y
1	0	0.4	$Y_1$

### Static Equivalent Load

$$P_0 = 0.5F_r + Y_0F_a$$

When  $F_r > 0.5F_r + Y_0F_a$ , use  $P_0 = F_r$

The values of  $e$ ,  $Y_1$ , and  $Y_0$  are given in the table below.

d	Boundary Dimensions (mm)					Cone r min	Cup r max	Basic Load Ratings (N) {kgf}				Limiting Speeds (rpm)	
	D	T	B	C	$C_r$			$C_{0r}$	$C_r$	$C_{0r}$	Grease	Oil	
92.075	146.050	33.338	34.925	26.195	3.5	3.3	169 000	280 000	17 300	28 500	2 400	3 200	
	148.430	28.575	28.971	21.433	3.5	3.0	140 000	218 000	14 300	22 300	2 200	3 000	
	152.400	39.688	36.322	30.162	3.5	3.2	183 000	285 000	18 700	29 100	2 200	3 200	
93.662	148.430	28.575	28.971	21.433	3.0	3.0	140 000	218 000	14 300	22 300	2 200	3 000	
	149.225	31.750	28.971	24.608	3.0	3.3	140 000	218 000	14 300	22 300	2 200	3 000	
	152.400	39.688	36.322	30.162	3.5	3.2	183 000	285 000	18 700	29 100	2 200	3 200	
95.000	150.000	35.000	34.000	27.000	3.0	2.5	183 000	285 000	18 700	29 100	2 200	3 200	
	146.050	33.338	34.925	26.195	3.5	3.3	169 000	280 000	17 300	28 500	2 400	3 200	
	148.430	28.575	28.971	21.433	3.0	3.0	140 000	218 000	14 300	22 300	2 200	3 000	
95.250	149.225	31.750	28.971	24.608	3.5	3.3	140 000	218 000	14 300	22 300	2 200	3 000	
	152.400	39.688	36.322	30.162	3.5	3.2	183 000	285 000	18 700	29 100	2 200	3 200	
	152.400	39.688	36.322	30.162	3.5	3.3	183 000	285 000	18 700	29 100	2 200	3 200	
96.838	148.430	28.575	28.971	21.433	3.5	3.0	140 000	218 000	14 300	22 300	2 200	3 000	
	149.225	31.750	28.971	24.608	3.5	3.3	140 000	218 000	14 300	22 300	2 200	3 000	
	152.400	39.688	36.322	30.162	3.5	3.2	183 000	285 000	18 700	29 100	2 200	3 200	
98.425	161.925	36.512	36.116	26.195	3.5	3.3	191 000	310 000	19 500	31 500	2 000	2 800	
	168.275	41.275	30.162	38.100	3.5	3.3	223 000	345 000	22 700	35 000	2 000	2 800	
	180.975	47.625	48.006	38.100	3.5	3.3	258 000	375 000	26 300	38 500	2 000	2 600	
99.982	190.500	57.150	57.531	44.450	3.5	3.3	355 000	500 000	36 000	51 000	1 900	2 600	
	190.500	57.150	57.531	46.038	3.5	3.3	390 000	520 000	39 500	53 500	1 900	2 600	
	190.500	57.150	57.531	46.038	6.4	3.3	390 000	520 000	39 500	53 500	1 900	2 600	
100.000	150.000	32.000	30.000	26.000	2.3	2.3	146 000	235 000	14 900	24 000	2 200	3 000	
	155.000	36.000	35.000	28.000	3.0	2.5	191 000	325 000	19 500	33 000	2 000	2 800	
	160.000	41.000	40.000	32.000	3.0	2.5	239 000	380 000	24 400	38 500	2 000	2 800	
100.012	157.162	36.512	36.116	26.195	3.5	3.3	191 000	310 000	19 500	31 500	2 000	2 800	

Bearing Numbers		Abutment and Fillet Dimensions (mm)				Cone r max	Cup r max	Eff. Load Centers (mm) a	Constant e	Axial Load Factors		Mass (kg)	
CONE	CUP	$d_a$	$d_b$	$D_a$	$D_b$					$Y_1$	$Y_0$	approx CONE	CUP
47890	47820	107	101	131	140	3.5	3.3	32.3	0.45	1.3	0.74	1.46	0.664
42362	42584	107	101	134	142	3.5	3	31.8	0.49	1.2	0.67	1.29	0.553
598	592 A	107	101	135	144	3.5	3.2	37.1	0.44	1.4	0.75	1.6	1.06
598 A	592 A	113	101	135	144	6.4	3.2	37.1	0.44	1.4	0.75	1.59	1.06
681	672	110	104	149	160	3.5	3.3	38.3	0.47	1.3	0.70	2.62	1.24
857	854	121	106	170	174	8	3.3	41.8	0.33	1.8	0.99	4.78	2.55
42368	42584	107	102	134	142	3	3	31.8	0.49	1.2	0.67	1.24	0.553
42368	42587	107	102	134	143	3	3.3	34.9	0.49	1.2	0.67	1.24	0.711
597	592 A	109	102	135	144	3.5	3.2	37.1	0.44	1.4	0.75	1.54	1.06
▲ JM 719149	▲ JM 719113	109	104	135	143	3	2.5	33.4	0.44	1.4	0.75	1.46	0.765
47896	47820	110	103	131	140	3.5	3.3	32.3	0.45	1.3	0.74	1.33	0.664
42375	42584	108	103	134	142	3	3	31.8	0.49	1.2	0.67	1.18	0.553
42376	42587	109	103	134	143	3.5	3.3	34.9	0.49	1.2	0.67	1.18	0.711
594	592 A	110	104	135	144	3.5	3.2	37.1	0.44	1.4	0.75	1.47	1.06
594	592	109	103	135	145	3.5	3.3	37.1	0.44	1.4	0.75	1.47	1.12
683	672	113	106	149	160	3.5	3.3	38.3	0.47	1.3	0.70	2.47	1.24
77375	77675	117	105	152	159	3.5	3.3	37.8	0.37	1.6	0.90	2.91	1.67
776	772	114	107	161	168	3.5	3.3	39.1	0.39	1.6	0.86	3.25	1.99
864	854	123	108	170	174	8	3.3	41.8	0.33	1.8	0.99	4.57	2.55
HH 221440	HH 221410	125	110	171	179	8	3.3	42.3	0.33	1.8	0.99	5.0	2.24
42381	42584	110	104	134	142	3.5	3	31.8	0.49	1.2	0.67	1.13	0.553
42381	42587	111	105	135	143	3.5	3.3	34.9	0.49	1.2	0.67	1.13	0.711
52387	52637	114	108	144	154	3.5	3.3	36.1	0.47	1.3	0.69	1.89	0.942
685	672	116	109	149	160	3.5	3.3	38.3	0.47	1.3	0.70	2.32	1.24
779	772	116	110	161	168	3.5	3.3	39.1	0.39	1.6	0.86	3.06	1.99
866	854	118	111	170	174	3.5	3.3	41.8	0.33	1.8	0.99	4.38	2.55
HH 221442	HH 221410	119	113	171	179	3.5	3.3	42.3	0.33	1.8	0.99	4.81	2.24
HH 221447	HH 221410	126	114	171	179	6.4	3.3	42.3	0.33	1.8	0.99	4.68	2.24
▲ JLM 820048	▲ JLM 820012	111	107	135	144	2.3	2.3	36.8	0.50	1.2	0.66	1.27	0.616
▲ JM 720249	▲ JM 720210	115	109	140	149	3	2.5	36.8	0.47	1.3	0.70	1.68	0.772
▲ JHM 720249	▲ JHM 720210	117	109	143	154	3	2.5	38.2	0.47	1.3	0.70	2.09	0.974
52393	52618	116	109	142	152	3.5	3.3	36.1	0.47	1.3	0.69	1.81	0.702

Note ▲ The tolerances are listed in Tables 2, 3 and 4 on Pages B109 and B110.

# SINGLE-ROW TAPERED ROLLER BEARINGS (INCH DESIGN)

Bore Diameter 101.600~117.475 mm

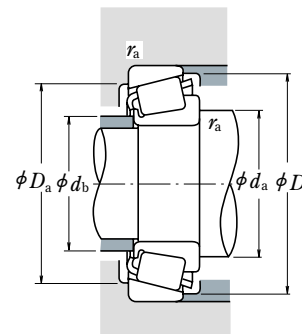
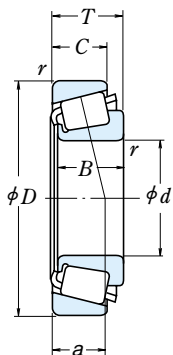

### Dynamic Equivalent Load

$$P = X F_r + Y F_a$$

$F_a/F_r \leq e$		$F_a/F_r > e$	
X	Y	X	Y
1	0	0.4	$Y_1$

### Static Equivalent Load

$$P_0 = 0.5 F_r + Y_0 F_a$$

When  $F_r > 0.5 F_r + Y_0 F_a$ , use  $P_0 = F_r$

The values of  $e$ ,  $Y_1$ , and  $Y_0$  are given in the table below.

	Boundary Dimensions (mm)					Cone $r$ min	Cup $r$ min	Basic Load Ratings (N)				Limiting Speeds (rpm)	
	$d$	$D$	$T$	$B$	$C$			$C_r$	$C_{0r}$	$C_r$	$C_{0r}$	Grease	Oil
<b>101.600</b>	157.162	36.512	36.116	26.195	3.5	3.3	191 000	310 000	19 500	31 500	2 000	2 800	
	161.925	36.512	36.116	26.195	3.5	3.3	191 000	310 000	19 500	31 500	2 000	2 800	
	168.275	41.275	41.275	30.162	3.5	3.3	223 000	345 000	22 700	35 000	2 000	2 800	
180.975	47.625	48.006	38.100	3.5	3.3	258 000	375 000	26 300	38 500	2 000	2 600		
	57.150	57.531	44.450	8.0	3.3	355 000	500 000	36 000	51 000	1 900	2 600		
	57.150	57.531	46.038	8.0	3.3	390 000	520 000	39 500	53 500	1 900	2 600		
	212.725	66.675	66.675	53.975	7.0	3.3	570 000	810 000	58 000	82 500	1 700	2 200	
	180.975	47.625	48.006	38.100	7.0	3.3	258 000	375 000	26 300	38 500	2 000	2 600	
<b>104.775</b>	180.975	47.625	48.006	38.100	3.5	3.3	258 000	375 000	26 300	38 500	2 000	2 600	
	190.500	47.625	49.212	34.925	3.5	3.3	296 000	465 000	30 000	47 000	1 800	2 400	
	190.500	47.625	49.212	34.925	3.5	3.3	296 000	465 000	30 000	47 000	1 800	2 400	
<b>106.362</b>	165.100	36.512	36.512	26.988	3.5	3.3	195 000	320 000	19 800	33 000	2 000	2 600	
<b>107.950</b>	158.750	23.020	21.438	15.875	3.5	3.3	102 000	165 000	10 400	16 800	2 000	2 800	
	159.987	34.925	34.925	26.988	3.5	3.3	164 000	315 000	16 700	32 000	2 000	2 800	
	161.925	34.925	34.925	26.988	3.5	3.3	164 000	280 000	16 800	28 600	2 000	2 800	
165.100	36.512	36.512	26.988	3.5	3.3	195 000	320 000	19 800	33 000	2 000	2 600		
	47.625	49.212	34.925	3.5	3.3	296 000	465 000	30 000	47 000	1 800	2 400		
	212.725	66.675	66.675	53.975	8.0	3.3	570 000	810 000	58 000	82 500	1 700	2 200	
<b>109.987</b>	159.987	34.925	34.925	26.988	3.5	3.3	164 000	315 000	16 700	32 000	2 000	2 800	
	159.987	34.925	34.925	26.988	8.0	3.3	164 000	315 000	16 700	32 000	2 000	2 800	
<b>109.992</b>	177.800	41.275	41.275	30.162	3.5	3.3	232 000	375 000	23 700	38 000	1 800	2 600	
<b>110.000</b>	165.000	35.000	35.000	26.500	3.0	2.5	195 000	320 000	19 800	33 000	2 000	2 600	
	180.000	47.000	46.000	38.000	3.0	2.5	310 000	490 000	31 500	50 000	1 900	2 600	
<b>111.125</b>	190.500	47.625	49.212	34.925	3.5	3.3	296 000	465 000	30 000	47 000	1 800	2 400	
<b>114.300</b>	152.400	21.433	21.433	16.670	1.5	1.5	89 500	178 000	9 100	18 100	2 000	2 800	
	177.800	41.275	41.275	30.162	3.5	3.3	232 000	375 000	23 700	38 000	1 800	2 600	
	180.000	34.925	31.750	25.400	3.5	0.8	174 000	254 000	17 800	25 900	1 800	2 400	
	190.500	47.625	49.212	34.925	3.5	3.3	296 000	465 000	30 000	47 000	1 800	2 400	
	212.725	66.675	66.675	53.975	7.0	3.3	475 000	700 000	48 500	71 500	1 700	2 400	
212.725	66.675	66.675	53.975	7.0	3.3	570 000	810 000	58 000	82 500	1 700	2 200		
<b>115.087</b>	190.500	47.625	49.212	34.925	3.5	3.3	296 000	465 000	30 000	47 000	1 800	2 400	
<b>117.475</b>	180.975	34.925	31.750	25.400	3.5	3.3	174 000	254 000	17 800	25 900	1 800	2 400	

Bearing Numbers		Abutment and Fillet Dimensions (mm)					Eff. Load Centers (mm)	Constant	Axial Load Factors		Mass (kg)		
CONE	CUP	$d_a$	$d_b$	$D_a$	$D_b$	Cone $r_a$ max			$e$	$Y_1$	$Y_0$	approx CONE	CUP
<b>52400</b>	<b>52618</b>	117	111	142	152	3.5	3.3	36.1	0.47	1.3	0.69	1.75	0.702
<b>52400</b>	<b>52637</b>	117	111	144	154	3.5	3.3	36.1	0.47	1.3	0.69	1.75	0.942
<b>687</b>	<b>672</b>	118	112	149	160	3.5	3.3	38.3	0.47	1.3	0.70	2.15	1.24
<b>780</b>	<b>772</b>	119	113	161	168	3.5	3.3	39.1	0.39	1.6	0.86	2.88	1.99
<b>861</b>	<b>854</b>	129	114	170	174	8	3.3	41.8	0.33	1.8	0.99	4.13	2.55
<b>HH 221449</b>	<b>HH 221410</b>	131	116	171	179	8	3.3	42.3	0.33	1.8	0.99	4.55	2.24
<b>HH 224335</b>	<b>HH 224310</b>	132	121	192	202	7	3.3	47.3	0.33	1.8	1.0	8.14	3.06
<b>787</b>	<b>772</b>	129	116	161	168	7	3.3	39.1	0.39	1.6	0.86	2.66	1.99
<b>782</b>	<b>772</b>	122	116	161	168	3.5	3.3	39.1	0.39	1.6	0.86	2.68	1.99
<b>71412</b>	<b>71750</b>	124	118	171	181	3.5	3.3	40.1	0.42	1.4	0.79	4.0	1.71
<b>56418</b>	<b>56650</b>	122	116	149	159	3.5	3.3	38.6	0.50	1.2	0.66	1.87	0.861
<b>37425</b>	<b>37625</b>	122	115	143	152	3.5	3.3	37.0	0.61	0.99	0.54	0.886	0.488
<b>LM 522546</b>	<b>LM 522510</b>	122	116	146	154	3.5	3.3	33.7	0.40	1.5	0.82	1.65	0.784
<b>48190</b>	<b>48120</b>	122	116	146	156	3.5	3.3	38.7	0.51	1.2	0.65	1.59	0.83
<b>56425</b>	<b>56650</b>	123	117	149	159	3.5	3.3	38.6	0.50	1.2	0.66	1.8	0.861
<b>71425</b>	<b>71750</b>	126	120	171	181	3.5	3.3	40.1	0.42	1.4	0.79	3.79	1.71
<b>HH 224340</b>	<b>HH 224310</b>	139	126	192	202	8	3.3	47.3	0.33	1.8	1.0	7.58	3.06
<b>LM 522549</b>	<b>LM 522510</b>	124	118	146	154	3.5	3.3	33.7	0.40	1.5	0.82	1.55	0.784
<b>LM 522548</b>	<b>LM 522510</b>	133	118	146	154	8	3.3	33.7	0.40	1.5	0.82	1.53	0.784
<b>64433</b>	<b>64700</b>	128	121	160	172	3.5	3.3	42.4	0.52	1.2	0.64	2.64	1.11
<b>▲ JM 822049</b>	<b>▲ JM 822010</b>	124	119	149	159	3	2.5	38.3	0.50	1.2	0.66	1.64	0.842
<b>▲ JHM 522649</b>	<b>▲ JHM 522610</b>	127	122	162	172	3	2.5	40.9	0.41	1.5	0.81	3.12	1.51
<b>71437</b>	<b>71750</b>	129	123	171	181	3.5	3.3	40.1	0.42	1.4	0.79	3.58	1.71
<b>L 623149</b>	<b>L 623110</b>	123	121	143	148	1.5	1.5	27.4	0.41	1.5	0.80	0.725	0.344
<b>64450</b>	<b>64700</b>	131	125	160	172	3.5	3.3	42.4	0.52	1.2	0.64	2.39	1.11
<b>68450</b>	<b>** 68709</b>	130	123	165	172	3.5	0.8	40.0	0.50	1.2	0.66	1.95	1.0
<b>71450</b>	<b>71750</b>	132	125	171	181	3.5	3.3	40.1	0.42	1.4	0.79	3.37	1.71
<b>938</b>	<b>932</b>	141	128	187	193	7	3.3	46.9	0.33	1.8	1.0	6.01	4.11
<b>HH 224346</b>	<b>HH 224310</b>	143	131	192	202	7	3.3	47.3	0.33	1.8	1.0	7.01	3.06
<b>71453</b>	<b>71750</b>	133	126	171	181	3.5	3.3	40.1	0.42	1.4	0.79	3.31	1.71
<b>68462</b>	<b>68712</b>	132	125	163	172	3.5	3.3	40.0	0.50	1.2	0.66	1.73	1.05

Notes \*\* The maximum outside diameter is listed and its tolerance is negative (See Table 8.4.2 on Pages A68 and A69).

▲ The tolerances are listed in Tables 2, 3 and 4 on Pages B109 and B110.

# SINGLE-ROW TAPERED ROLLER BEARINGS (INCH DESIGN)

Bore Diameter 120.000~165.100 mm

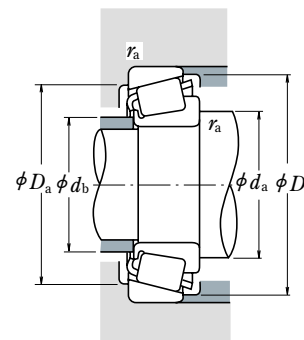
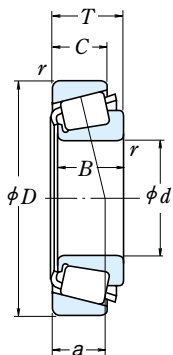

### Dynamic Equivalent Load

$$P = X F_r + Y F_a$$

$F_a / F_r \leq e$		$F_a / F_r > e$	
X	Y	X	Y
1	0	0.4	$Y_1$

### Static Equivalent Load

$$P_0 = 0.5 F_r + Y_0 F_a$$

When  $F_r > 0.5 F_r + Y_0 F_a$ , use  $P_0 = F_r$

The values of  $e$ ,  $Y_1$ , and  $Y_0$  are given in the table below.

d	Boundary Dimensions (mm)					Cone r min	Cup r max	Basic Load Ratings (N) {kgf}				Limiting Speeds (rpm)	
	D	T	B	C	$C_r$			$C_{0r}$	$C_r$	$C_{0r}$	Grease	Oil	
120.000	170.000	25.400	25.400	19.050	3.3	3.3	130 000	219 000	13 200	22 300	1 900	2 600	
	174.625	35.720	36.512	27.783	3.5	1.5	212 000	385 000	21 600	39 000	1 900	2 600	
120.650	182.562	39.688	38.100	33.338	3.5	3.3	228 000	445 000	23 200	45 000	1 800	2 400	
	206.375	47.625	47.625	34.925	3.3	3.3	320 000	530 000	32 500	54 000	1 600	2 200	
123.825	182.562	39.688	38.100	33.338	3.5	3.3	228 000	445 000	23 200	45 000	1 800	2 400	
	125.000	175.000	25.400	25.400	18.288	3.3	3.3	134 000	232 000	13 700	23 600	1 800	2 400
127.000	165.895	18.258	17.462	13.495	1.5	1.5	84 500	149 000	8 650	15 200	1 900	2 600	
	182.562	39.688	38.100	33.338	3.5	3.3	228 000	445 000	23 200	45 000	1 800	2 400	
	196.850	46.038	46.038	38.100	3.5	3.3	315 000	560 000	32 000	57 500	1 700	2 200	
	215.900	47.625	47.625	34.925	3.5	3.3	287 000	495 000	29 300	50 000	1 500	2 000	
	128.588	206.375	47.625	47.625	34.925	3.3	3.3	320 000	530 000	32 500	54 000	1 600	2 200
130.000	206.375	47.625	47.625	34.925	3.5	3.3	320 000	530 000	32 500	54 000	1 600	2 200	
130.175	203.200	46.038	46.038	38.100	3.5	3.3	315 000	560 000	32 000	57 500	1 700	2 200	
	206.375	47.625	47.625	34.925	3.5	3.3	320 000	530 000	32 500	54 000	1 600	2 200	
133.350	177.008	25.400	26.195	20.638	1.5	1.5	124 000	258 000	12 700	26 300	1 800	2 400	
	190.500	39.688	39.688	33.338	3.5	3.3	240 000	485 000	24 500	49 500	1 700	2 200	
	196.850	46.038	46.038	38.100	3.5	3.3	315 000	560 000	32 000	57 500	1 700	2 200	
	215.900	47.625	47.625	34.925	3.5	3.3	287 000	495 000	29 300	50 000	1 500	2 000	
136.525	190.500	39.688	39.688	33.338	3.5	3.3	240 000	485 000	24 500	49 500	1 700	2 200	
	217.488	47.625	47.625	34.925	3.5	3.3	287 000	495 000	29 300	50 000	1 500	2 000	
139.700	187.325	28.575	29.370	23.020	1.5	1.5	153 000	305 000	15 600	31 500	1 700	2 200	
	215.900	47.625	47.625	34.925	3.5	3.3	287 000	495 000	29 300	50 000	1 500	2 000	
	254.000	66.675	66.675	47.625	7.0	3.3	515 000	830 000	52 500	84 500	1 300	1 800	
142.875	200.025	41.275	39.688	34.130	3.5	3.3	227 000	460 000	23 100	46 500	1 600	2 200	
146.050	193.675	28.575	28.575	23.020	1.5	1.5	170 000	355 000	17 300	36 500	1 600	2 200	
	236.538	57.150	56.642	44.450	3.5	3.3	455 000	720 000	46 000	73 500	1 400	1 900	
	254.000	66.675	66.675	47.625	7.0	3.3	515 000	830 000	52 500	84 500	1 300	1 800	
149.225	254.000	66.675	66.675	47.625	7.0	3.3	515 000	830 000	52 500	84 500	1 300	1 800	
152.400	254.000	66.675	66.675	47.625	7.0	3.3	515 000	830 000	52 500	84 500	1 300	1 800	
158.750	225.425	41.275	39.688	33.338	3.5	3.3	240 000	540 000	24 400	55 000	1 400	1 900	
	165.100	247.650	47.625	47.625	38.100	3.5	3.3	345 000	705 000	35 500	71 500	1 300	1 700

Bearing Numbers		Abutment and Fillet Dimensions (mm)				Cone r_a max	Cup r_a max	Eff. Load Centers (mm) a	Constant e	Axial Load Factors		Mass (kg)		
CONE	CUP	d_a	d_b	D_a	D_b					Y_1	Y_0	approx CONE	CUP	
▲ JL 724348	▲ JL 724314	132	127	156	163	3.3	3.3	32.9	0.46	1.3	0.72	1.08	0.591	
	* M 224748	M 224710	135	129	163	168	3.5	1.5	32.2	0.33	1.8	0.99	1.9	0.866
48282	48220	136	133	168	176	3.5	3.3	34.2	0.31	2.0	1.1	2.56	1.14	
	795	792	139	134	186	198	3.3	3.3	45.7	0.46	1.3	0.72	4.44	1.9
48286	48220	139	133	168	176	3.5	3.3	34.2	0.31	2.0	1.1	2.37	1.14	
	▲ JL 725346	▲ JL 725316	138	133	161	168	3.3	3.3	34.3	0.48	1.3	0.69	1.19	0.573
LL 225749	LL 225710	135	132	158	160	1.5	1.5	24.2	0.33	1.8	0.99	0.647	0.288	
	48290	48220	141	135	168	176	3.5	3.3	34.2	0.31	2.0	1.1	2.19	1.14
	67388	67322	144	138	180	189	3.5	3.3	39.7	0.34	1.7	0.96	3.74	1.46
	74500	74850	148	141	196	208	3.5	3.3	48.4	0.49	1.2	0.68	4.92	1.99
	799	792	146	140	186	198	3.3	3.3	45.7	0.46	1.3	0.72	3.86	1.9
797	792	148	141	186	198	3.5	3.3	45.7	0.46	1.3	0.72	3.76	1.9	
67389	67320	146	141	183	191	3.5	3.3	39.7	0.34	1.7	0.96	3.51	2.06	
	799 A	792	148	142	186	198	3.5	3.3	45.7	0.46	1.3	0.72	3.74	1.9
L 327249	L 327210	143	141	167	171	1.5	1.5	29.5	0.35	1.7	0.95	1.18	0.55	
	48385	48320	148	142	177	184	3.5	3.3	35.9	0.32	1.9	1.0	2.58	1.16
	67390	67322	149	143	180	189	3.5	3.3	39.7	0.34	1.7	0.96	3.27	1.46
	74525	74850	152	146	196	208	3.5	3.3	48.4	0.49	1.2	0.68	4.44	1.99
48393	48320	151	144	177	184	3.5	3.3	35.9	0.32	1.9	1.0	2.37	1.16	
	74537	74856	155	148	197	210	3.5	3.3	48.4	0.49	1.2	0.68	4.19	2.13
LM 328448	LM 328410	149	147	176	182	1.5	1.5	31.7	0.36	1.7	0.93	1.59	0.67	
	74550	74850	158	151	196	208	3.5	3.3	48.4	0.49	1.2	0.68	3.93	1.99
	99550	99100	170	156	227	238	7	3.3	55.3	0.41	1.5	0.81	9.99	3.83
48685	48620	158	151	185	193	3.5	3.3	37.6	0.34	1.8	0.98	2.63	1.19	
	36690	36620	155	154	182	188	1.5	1.5	33.5	0.37	1.6	0.90	1.64	0.725
HM 231140	HM 231110	164	160	217	224	3.5	3.3	45.9	0.32	1.9	1.0	6.07	2.93	
	99575	99100	175	162	227	238	7	3.3	55.3	0.41	1.5	0.81	9.24	3.83
99587	99100	178	165	227	238	7	3.3	55.3	0.41	1.5	0.81	8.86	3.83	
	99600	99100	181	167	227	238	7	3.3	55.3	0.41	1.5	0.81	8.46	3.83
46780	46720	176	169	209	218	3.5	3.3	44.3	0.38	1.6	0.86	3.69	1.66	
	67780	67720	185	179	229	240	3.5	3.3	52.4	0.44	1.4	0.75	5.83	2.33

Notes \* The maximum bore diameter is listed and its tolerance is negative (See Table 8.4.1 on Page A68).

▲ The tolerances are listed in Tables 2, 3 and 4 on Pages B109 and B110.



# SINGLE-ROW TAPERED ROLLER BEARINGS (INCH DESIGN)

Bore Diameter 170.000~206.375 mm

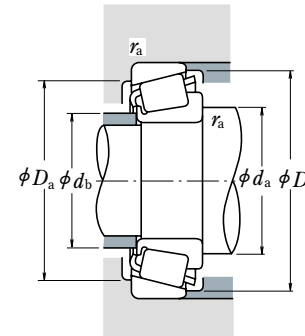
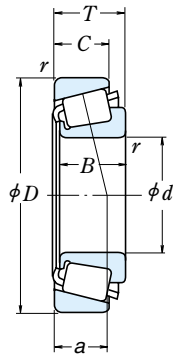

### Dynamic Equivalent Load

$$P = XF_r + YF_a$$

$F_a/F_r \leq e$		$F_a/F_r > e$	
X	Y	X	Y
1	0	0.4	$Y_1$

### Static Equivalent Load

$$P_0 = 0.5F_r + Y_0F_a$$

When  $F_r > 0.5F_r + Y_0F_a$ , use  $P_0 = F_r$

The values of  $e$ ,  $Y_1$ , and  $Y_0$  are given in the table below.

$d$	Boundary Dimensions (mm)					Cone $r_{min}$	Cup $r_{max}$	Basic Load Ratings (N)				Limiting Speeds (rpm)	
	$D$	$T$	$B$	$C$	$C_r$			$C_{0r}$	$C_r$	$C_{0r}$	Grease	Oil	
<b>170.000</b>	230.000	39.000	38.000	31.000	3.0	2.5	278 000	520 000	28 300	53 000	1 300	1 800	
	240.000	46.000	44.500	37.000	3.0	2.5	380 000	720 000	39 000	73 000	1 300	1 800	
<b>174.625</b>	247.650	47.625	47.625	38.100	3.5	3.3	345 000	705 000	35 500	71 500	1 300	1 700	
<b>177.800</b>	227.012	30.162	30.162	23.020	1.5	1.5	181 000	415 000	18 500	42 000	1 300	1 800	
	247.650	47.625	47.625	38.100	3.5	3.3	345 000	705 000	35 500	71 500	1 300	1 700	
	260.350	53.975	53.975	41.275	3.5	3.3	455 000	835 000	46 500	85 000	1 200	1 700	
<b>190.000</b>	260.000	46.000	44.000	36.500	3.0	2.5	370 000	730 000	38 000	74 500	1 100	1 600	
<b>190.500</b>	266.700	47.625	46.833	38.100	3.5	3.3	345 000	720 000	35 000	73 000	1 100	1 500	
<b>200.000</b>	300.000	65.000	62.000	51.000	3.5	2.5	615 000	1 130 000	62 500	116 000	1 000	1 400	
<b>203.200</b>	282.575	46.038	46.038	36.512	3.5	3.3	365 000	800 000	37 500	81 500	1 000	1 400	
<b>206.375</b>	282.575	46.038	46.038	36.512	3.5	3.3	365 000	800 000	37 500	81 500	1 000	1 400	

Bearing Numbers		Abutment and Fillet Dimensions (mm)						Eff. Load Centers (mm) $a$	Constant $e$	Axial Load Factors		Mass (kg)	
CONE	CUP	$d_a$	$d_b$	$D_a$	$D_b$	Cone $r_a$	Cup $r_a$			$Y_1$	$Y_0$	CONE approx	CUP
<b>▲ JHM 534149</b>	<b>▲ JHM 534110</b>	184	178	217	224	3	2.5	43.2	0.38	1.6	0.86	3.1	1.3
<b>▲ JM 734449</b>	<b>▲ JM 734410</b>	185	180	222	232	3	2.5	50.5	0.44	1.4	0.75	4.42	2.02
<b>67787</b>	<b>67720</b>	192	185	229	240	3.5	3.3	52.4	0.44	1.4	0.75	4.88	2.33
<b>36990</b>	<b>36920</b>	189	186	214	221	1.5	1.5	42.9	0.44	1.4	0.75	2.1	0.907
<b>67790</b>	<b>67720</b>	194	188	229	240	3.5	3.3	52.4	0.44	1.4	0.75	4.56	2.33
<b>M 236849</b>	<b>M 236810</b>	195	192	241	249	3.5	3.3	47.5	0.33	1.8	0.99	6.49	2.86
<b>▲ JM 738249</b>	<b>▲ JM 738210</b>	206	200	242	252	3	2.5	56.4	0.48	1.3	0.69	4.73	2.2
<b>67885</b>	<b>67820</b>	209	203	246	259	3.5	3.3	57.9	0.48	1.3	0.69	5.4	2.64
<b>▲ JHM 840449</b>	<b>▲ JHM 840410</b>	223	215	273	289	3.5	2.5	73.1	0.52	1.2	0.63	10.3	5.19
<b>67983</b>	<b>67920</b>	222	216	260	275	3.5	3.3	61.9	0.51	1.2	0.65	6.03	2.82
<b>67985</b>	<b>67920</b>	224	219	260	275	3.5	3.3	61.9	0.51	1.2	0.65	5.66	2.82

Note ▲ The tolerances are listed in Tables 2, 3 and 4 on Pages B109 and B110.

Bore Diameter 40~90 mm

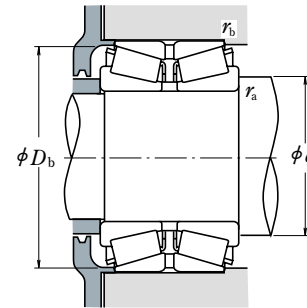
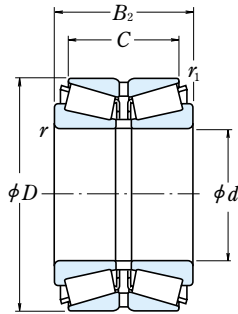

Dynamic Equivalent Load

$$P = XF_r + YF_a$$

$F_a/F_r \leq e$		$F_a/F_r > e$	
X	Y	X	Y
1	$Y_3$	0.67	$Y_2$

Static Equivalent Load

$$P_0 = F_r + Y_0 F_a$$

The values of  $e$ ,  $Y_2$ ,  $Y_3$ , and  $Y_0$  are given in the table below.

d	Boundary Dimensions (mm)					Basic Load Ratings (N)		Limiting Speeds (rpm)	
	D	B <sub>2</sub>	C	r <sub>min</sub>	r <sub>1min</sub>	C <sub>r</sub>	C <sub>0r</sub>	Grease	Oil
40	80	45	37.5	1.5	0.6	109 000	140 000	3 700	5 100
	85	47	37.5	1.5	0.6	117 000	159 000	3 400	4 700
45	85	55	43.5	1.5	0.6	143 000	204 000	3 400	4 700
	90	48	38.5	1.5	0.6	131 000	183 000	3 200	4 400
50	90	49	39.5	1.5	0.6	131 000	183 000	3 200	4 400
	90	55	43.5	1.5	0.6	150 000	218 000	3 200	4 400
55	110	64	51.5	2.5	0.6	224 000	297 000	2 700	3 700
	100	51	41.5	2	0.6	162 000	226 000	2 900	3 900
60	100	52	42.5	2	0.6	162 000	226 000	2 900	3 900
	100	60	48.5	2	0.6	188 000	274 000	2 900	3 900
65	120	70	57	2.5	0.6	256 000	342 000	2 500	3 400
	110	53	43.5	2	0.6	178 000	246 000	2 700	3 600
70	110	66	54.5	2	0.6	225 000	335 000	2 700	3 600
	130	74	59	3	1	298 000	405 000	2 300	3 200
75	120	56	46.5	2	0.6	210 000	300 000	2 400	3 200
	120	57	47.5	2	0.6	210 000	300 000	2 400	3 200
80	120	73	61.5	2	0.6	269 000	405 000	2 400	3 300
	140	79	63	3	1	340 000	465 000	2 100	2 900
85	125	57	46.5	2	0.6	227 000	325 000	2 300	3 100
	125	59	48.5	2	0.6	227 000	325 000	2 300	3 100
90	125	74	61.5	2	0.6	270 000	410 000	2 300	3 100
	150	83	67	3	1	390 000	535 000	2 000	2 700
95	130	62	51.5	2	0.6	245 000	365 000	2 200	3 000
	130	74	61.5	2	0.6	283 000	440 000	2 200	3 000
100	160	87	69	3	1	435 000	600 000	1 900	2 500
	140	61	49	2.5	0.6	269 000	390 000	2 000	2 800
105	140	64	51.5	2.5	0.6	269 000	390 000	2 000	2 800
	140	78	63.5	2.5	0.6	330 000	505 000	2 000	2 800
110	170	92	73	3	1	475 000	655 000	1 700	2 400
	150	70	57	2.5	0.6	315 000	465 000	1 900	2 600
115	150	86	69	2.5	0.6	360 000	555 000	1 900	2 600
	180	98	77	4	1	530 000	745 000	1 600	2 200
120	160	71	58	2.5	0.6	345 000	510 000	1 800	2 400
	160	74	61	2.5	0.6	345 000	510 000	1 800	2 400
125	160	94	77	2.5	0.6	440 000	700 000	1 800	2 400

Bearing Numbers	Abutment and Fillet Dimensions (mm)				Constant e	Axial Load Factors			Mass (kg) approx
	d <sub>a min</sub>	D <sub>b min</sub>	r <sub>a max</sub>	r <sub>b max</sub>		Y <sub>2</sub>	Y <sub>3</sub>	Y <sub>0</sub>	
HR 40 KBE 42+L	51	75	1.5	0.6	0.37	2.7	1.8	1.8	0.97
HR 45 KBE 42+L	56	81	1.5	0.6	0.40	2.5	1.7	1.6	1.08
HR 45 KBE 52X+L	56	81	1.5	0.6	0.40	2.5	1.7	1.6	1.31
HR 50 KBE 042+L	61	87	1.5	0.6	0.42	2.4	1.6	1.6	1.20
HR 50 KBE 42+L	61	87	1.5	0.6	0.42	2.4	1.6	1.6	1.22
HR 50 KBE 52X+L	61	87	1.5	0.6	0.42	2.4	1.6	1.6	1.39
HR 50 KBE 043+L	65	104	2	0.6	0.35	2.9	2.0	1.9	2.77
HR 55 KBE 042+L	67	96	2	0.6	0.40	2.5	1.7	1.6	1.59
HR 55 KBE 1003+L	67	96	2	0.6	0.40	2.5	1.7	1.6	1.63
HR 55 KBE 52X+L	67	97	2	0.6	0.40	2.5	1.7	1.6	1.88
HR 55 KBE 43+L	70	113	2	0.6	0.35	2.9	2.0	1.9	3.52
HR 60 KBE 042+L	72	105	2	0.6	0.40	2.5	1.7	1.6	2.03
HR 60 KBE 52X+L	72	106	2	0.6	0.40	2.5	1.7	1.6	2.52
HR 60 KBE 43+L	78	122	2.5	1	0.35	2.9	2.0	1.9	4.40
HR 65 KBE 42+L	77	115	2	0.6	0.40	2.5	1.7	1.6	2.58
HR 65 KBE 1202+L	77	115	2	0.6	0.40	2.5	1.7	1.6	2.61
HR 65 KBE 52X+L	77	117	2	0.6	0.40	2.5	1.7	1.6	3.35
HR 65 KBE 43+L	83	132	2.5	1	0.55	2.9	2.0	1.9	5.42
HR 70 KBE 042+L	82	120	2	0.6	0.42	2.4	1.6	1.6	2.79
HR 70 KBE 42+L	82	120	2	0.6	0.42	2.4	1.6	1.6	2.85
HR 70 KBE 52X+L	82	121	2	0.6	0.42	2.4	1.6	1.6	3.58
HR 70 KBE 43+L	88	142	2.5	1	0.35	2.9	2.0	1.9	6.45
HR 75 KBE 42+L	87	126	2	0.6	0.44	2.3	1.6	1.5	3.15
HR 75 KBE 52X+L	87	127	2	0.6	0.44	2.3	1.6	1.5	3.73
HR 75 KBE 043+L	93	151	2.5	1	0.35	2.9	2.0	1.9	7.66
HR 80 KBE 042+L	95	134	2	0.6	0.42	2.4	1.6	1.6	3.70
HR 80 KBE 42+L	95	134	2	0.6	0.42	2.4	1.6	1.6	3.70
HR 80 KBE 52X+L	95	136	2	0.6	0.42	2.4	1.6	1.6	4.59
HR 80 KBE 043+L	98	161	2.5	1	0.35	2.9	2.0	1.9	9.02
HR 85 KBE 42+L	100	143	2	0.6	0.42	2.4	1.6	1.6	4.69
HR 85 KBE 52X+L	100	144	2	0.6	0.42	2.4	1.6	1.6	5.70
HR 85 KBE 043+L	106	169	3	1	0.35	2.9	2.0	1.9	10.8
HR 90 KBE 042+L	105	152	2	0.6	0.42	2.4	1.6	1.6	5.53
HR 90 KBE 42+L	105	152	2	0.6	0.42	2.4	1.6	1.6	5.71
HR 90 KBE 52X+L	105	154	2	0.6	0.42	2.4	1.6	1.6	7.26

Remarks For other double-row tapered roller bearings not listed above, please contact NSK.

Bore Diameter 90~120 mm

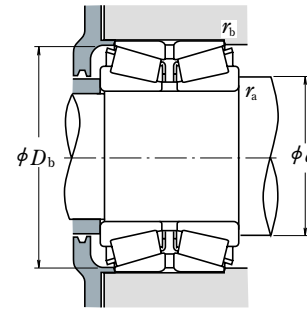
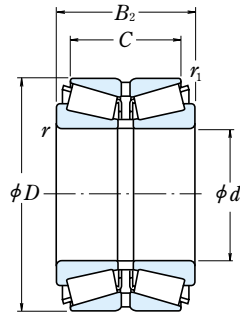

Dynamic Equivalent Load

$$P = XF_r + YF_a$$

$F_a/F_r \leq e$		$F_a/F_r > e$	
X	Y	X	Y
1	$Y_3$	0.67	$Y_2$

Static Equivalent Load

$$P_0 = F_r + Y_0 F_a$$

The values of  $e$ ,  $Y_2$ ,  $Y_3$ , and  $Y_0$  are given in the table below.

d	Boundary Dimensions (mm)					Basic Load Ratings (N)		Limiting Speeds (rpm)	
	D	B <sub>2</sub>	C	r <sub>min</sub>	r <sub>1min</sub>	C <sub>r</sub>	C <sub>0r</sub>	Grease	Oil
90	190	102	81	4	1	595 000	845 000	1 600	2 100
	190	144	115	4	1	770 000	1 180 000	1 600	2 200
95	170	78	63	3	1	385 000	570 000	1 700	2 300
	170	100	83	3	1	495 000	800 000	1 700	2 300
	200	108	85	4	1	640 000	910 000	1 500	2 000
100	165	52	46	2.5	0.6	222 000	340 000	1 700	2 300
	180	81	64	3	1	435 000	665 000	1 600	2 200
	180	81	65	3	1	435 000	665 000	1 600	2 200
	180	82	66	3	1	435 000	665 000	1 600	2 200
	180	83	67	3	1	435 000	665 000	1 600	2 200
	180	105	85	3	1	555 000	905 000	1 600	2 200
	180	107	87	3	1	555 000	905 000	1 600	2 200
	180	110	90	3	1	555 000	905 000	1 600	2 200
	215	112	87	4	1	725 000	1 050 000	1 400	1 900
	105	190	88	70	3	1	480 000	735 000	1 500
190		117	96	3	1	620 000	1 020 000	1 500	2 000
190		115	95	3	1	620 000	1 020 000	1 500	2 000
225		116	91	4	1	780 000	1 130 000	1 300	1 800
110		180	56	50	2.5	0.6	264 000	400 000	1 500
	180	70	56	2.5	0.6	340 000	555 000	1 500	2 000
	180	125	100	2.5	0.6	550 000	1 060 000	1 500	2 100
	200	90	72	3	1	540 000	840 000	1 400	1 900
	200	92	74	3	1	540 000	840 000	1 400	1 900
	200	120	100	3	1	685 000	1 130 000	1 400	1 900
	200	121	101	3	1	685 000	1 130 000	1 400	1 900
	240	118	93	4	1.5	830 000	1 190 000	1 200	1 700
120	180	46	41	2.5	0.6	184 000	296 000	1 500	2 000
	180	58	46	2.5	0.6	260 000	450 000	1 500	2 000
	200	62	55	2.5	0.6	310 000	500 000	1 400	1 800
	200	78	62	2.5	0.6	415 000	690 000	1 400	1 900
	200	100	84	2.5	0.6	515 000	885 000	1 400	1 800
	215	97	78	3	1	575 000	900 000	1 300	1 800
	215	132	109	3	1	750 000	1 270 000	1 300	1 800
	260	128	101	4	1	915 000	1 310 000	1 100	1 500
	260	188	145	4	1	1 320 000	2 110 000	1 100	1 500

Bearing Numbers	Abutment and Fillet Dimensions (mm)				Constant e	Axial Load Factors			Mass (kg) approx
	d <sub>a min</sub>	D <sub>b min</sub>	r <sub>a max</sub>	r <sub>b max</sub>		Y <sub>2</sub>	Y <sub>3</sub>	Y <sub>0</sub>	
HR 90 KBE 043+L	111	178	3	1	0.35	2.9	2.0	1.9	12.7
HR 90 KBE 1901+L	111	179	3	1	0.35	2.9	2.0	1.9	17.9
HR 95 KBE 42+L	113	161	2.5	1	0.42	2.4	1.6	1.6	6.75
HR 95 KBE 52+L	113	163	2.5	1	0.42	2.4	1.6	1.6	8.60
HR 95 KBE 43+L	116	187	3	1	0.35	2.9	2.0	1.9	14.7
100 KBE 31+L	115	156	2	0.6	0.33	3.0	2.0	2.0	4.04
HR100 KBE 1805+L	118	170	2.5	1	0.42	2.4	1.6	1.6	8.16
HR100 KBE 042+L	118	170	2.5	1	0.42	2.4	1.6	1.6	8.13
HR100 KBE 1801+L	118	170	2.5	1	0.42	2.4	1.6	1.6	8.22
HR100 KBE 42+L	118	170	2.5	1	0.42	2.4	1.6	1.6	8.7
HR100 KBE 1802+L	118	173	2.5	1	0.42	2.4	1.6	1.6	10.6
HR100 KBE 52X+L	118	173	2.5	1	0.42	2.4	1.6	1.6	10.7
HR100 KBE 1804+L	118	173	2.5	1	0.42	2.4	1.6	1.6	11
HR100 KBE 043+L	121	200	3	1	0.35	2.9	2.0	1.9	18.1
HR105 KBE 42X+L	123	179	2.5	1	0.42	2.4	1.6	1.6	9.76
HR105 KBE 1902+L	123	182	2.5	1	0.42	2.4	1.6	1.6	13.4
HR105 KBE 52+L	123	182	2.5	1	0.42	2.4	1.6	1.6	13.1
HR105 KBE 043+L	126	209	3	1	0.35	2.9	2.0	1.9	20.4
110 KBE 31+L	125	172	2	0.6	0.39	2.6	1.7	1.7	5.11
110 KBE 031+L	125	172	2	0.6	0.39	2.6	1.7	1.7	6.33
110 KBE 1802+L	125	172	2	0.6	0.26	3.8	2.6	2.5	11.4
HR110 KBE 42+L	128	190	2.5	1	0.42	2.4	1.6	1.6	11.2
HR110 KBE 42X+L	128	190	2.5	1	0.42	2.4	1.6	1.6	11.5
HR110 KBE 2001+L	128	193	2.5	1	0.42	2.4	1.6	1.6	15.4
HR110 KBE 52X+L	128	193	2.5	1	0.42	2.4	1.6	1.6	15.2
HR110 KBE 043+L	131	223	3	1.5	0.35	2.9	2.0	1.9	23.6
120 KBE 30+L	135	172	2	0.6	0.40	2.5	1.7	1.6	3.75
120 KBE 030+L	135	172	2	0.6	0.39	2.6	1.7	1.7	4.64
120 KBE 31+L	135	190	2	0.6	0.39	2.6	1.7	1.7	7.35
120 KBE 031+L	135	190	2	0.6	0.39	2.6	1.7	1.7	8.97
120 KBE 2001+L	135	193	2	0.6	0.37	2.7	1.8	1.8	11.3
HR120 KBE 42X+L	138	204	2.5	1	0.44	2.3	1.6	1.5	13.7
HR120 KBE 52X+L	138	207	2.5	1	0.44	2.3	1.6	1.5	18.8
HR120 KBE 43+L	141	240	3	1	0.35	2.9	2.0	1.9	29.4
HR120 KBE 2601+L	141	242	3	1	0.35	2.9	2.0	1.9	44.6

Remarks For other double-row tapered roller bearings not listed above, please contact NSK.

Bore Diameter 125~150 mm

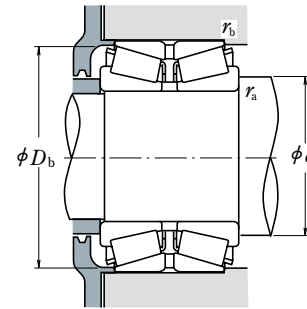
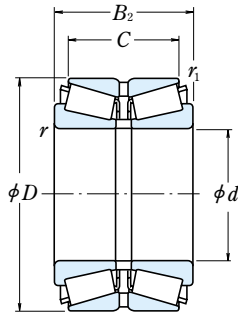

Dynamic Equivalent Load

$$P = XF_r + YF_a$$

$F_a/F_r \leq e$		$F_a/F_r > e$	
X	Y	X	Y
1	$Y_3$	0.67	$Y_2$

Static Equivalent Load

$$P_0 = F_r + Y_0 F_a$$

The values of  $e$ ,  $Y_2$ ,  $Y_3$ , and  $Y_0$  are given in the table below.

d	Boundary Dimensions (mm)					Basic Load Ratings (N)		Limiting Speeds (rpm)	
	D	B <sub>2</sub>	C	r <sub>min</sub>	r <sub>1 min</sub>	C <sub>r</sub>	C <sub>0r</sub>	Grease	Oil
125	210	110	88	4	1	560 000	1 030 000	1 300	1 800
130	230	98	78.5	4	1	640 000	1 010 000	1 200	1 600
	230	100	80.5	4	1	640 000	1 010 000	1 200	1 600
	280	137	107.5	5	1.5	940 000	1 350 000	1 000	1 400
140	230	145	115	4	1	905 000	1 580 000	1 200	1 700
	230	145	117.5	4	1	905 000	1 580 000	1 200	1 700
	230	150	120	4	1	905 000	1 580 000	1 200	1 700
	210	53	47	2.5	0.6	280 000	495 000	1 200	1 700
150	210	106	94	2.5	0.6	555 000	1 200 000	1 300	1 700
	210	66	53	2.5	1	305 000	530 000	1 200	1 700
	225	68	61	3	1	400 000	630 000	1 200	1 600
	225	84	68	3	1	490 000	850 000	1 200	1 600
	225	85	68	3	1	490 000	850 000	1 200	1 600
	230	120	94	3	1	685 000	1 270 000	1 200	1 600
	230	140	110	3	1	820 000	1 550 000	1 200	1 600
	240	132	106	4	1.5	685 000	1 360 000	1 100	1 500
	250	102	82.5	4	1	670 000	1 030 000	1 100	1 500
	250	153	125.5	4	1	1 040 000	1 830 000	1 100	1 500
	300	145	115.5	5	1.5	1 030 000	1 480 000	1 000	1 300
	150	225	56	50	3	1	300 000	545 000	1 200
225		70	56	3	1	395 000	685 000	1 200	1 600
250		80	71	3	1	510 000	810 000	1 100	1 400
250		100	80	3	1	630 000	1 090 000	1 100	1 400
250		115	95	3	1	745 000	1 320 000	1 100	1 500
260		150	115	4	1	815 000	1 520 000	1 100	1 400
270		109	87	4	1	830 000	1 330 000	1 000	1 400
270		164	130	4	1	1 210 000	2 150 000	1 000	1 400
270		174	140	4	1	1 210 000	2 150 000	1 000	1 400
320		154	120	5	1.5	1 420 000	2 130 000	900	1 200

Remarks For other double-row tapered roller bearings not listed above, please contact NSK.

Bearing Numbers	Abutment and Fillet Dimensions (mm)				Constant e	Axial Load Factors			Mass (kg) approx
	d <sub>a min</sub>	D <sub>b min</sub>	r <sub>a max</sub>	r <sub>b max</sub>		Y <sub>2</sub>	Y <sub>3</sub>	Y <sub>0</sub>	
125 KBE 2101+L	146	201	3	1	0.43	2.3	1.6	1.5	14.5
HR130 KBE 42+L	151	220	3	1	0.44	2.3	1.6	1.5	15.8
HR130 KBE 2301+L	151	220	3	1	0.44	2.3	1.6	1.5	15.9
130 KBE 43+L	157	258	4	1.5	0.36	2.8	1.9	1.8	35
HR130 KBE 2302+L	151	221	3	1	0.44	2.3	1.6	1.5	24.1
HR130 KBE 52+L	151	222	3	1	0.44	2.3	1.6	1.5	23.8
HR130 KBE 2303+L	151	221	3	1	0.44	2.3	1.6	1.5	24.2
140 KBE 30+L	155	202	2	0.6	0.39	2.6	1.7	1.7	6.02
140 KBE 030+L	155	202	2	1	0.40	2.5	1.7	1.6	7.02
140 KBE 2101+L	155	202	2	0.6	0.33	3.0	2.0	2.0	12.3
140 KBE 31+L	158	216	2.5	1	0.39	2.6	1.7	1.7	9.31
140 KBE 031+L	158	215	2.5	1	0.39	2.6	1.7	1.7	11.6
140 KBE 2201+L	158	215	2.5	1	0.39	2.6	1.7	1.7	11.7
140 KBE 2301+L	158	220	2.5	1	0.33	3.0	2.0	2.0	17.6
140 KBE 2302+L	158	221	2.5	1	0.35	2.9	2.0	1.9	20.7
140 KBE 2401+L	161	227	3	1.5	0.44	2.3	1.5	1.5	22.7
HR140 KBE 42+L	161	237	3	1	0.44	2.3	1.6	1.5	18.9
HR140 KBE 52X+L	161	241	3	1	0.44	2.3	1.6	1.5	29.6
140 KBE 43+L	167	275	4	1.5	0.36	2.8	1.9	1.8	42.6
150 KBE 30+L	168	213	2.5	1	0.35	2.9	2.0	1.9	7.41
150 KBE 030+L	168	215	2.5	1	0.35	2.9	2.0	1.9	8.70
150 KBE 31+L	168	240	2.5	1	0.40	2.5	1.7	1.6	14.2
150 KBE 031+L	168	238	2.5	1	0.39	2.6	1.7	1.7	17.8
150 KBE 2502+L	168	238	2.5	1	0.37	2.7	1.8	1.8	20.9
150 KBE 2601+L	171	242	3	1	0.43	2.3	1.6	1.5	30.0
HR150 KBE 42+L	171	253	3	1	0.44	2.3	1.6	1.5	24.3
HR150 KBE 52X+L	171	257	3	1	0.44	2.3	1.6	1.5	37.3
HR150 KBE 2701+L	171	257	3	1	0.44	2.3	1.6	1.5	39.7
HR150 KBE 43+L	177	295	4	1.5	0.35	2.9	2.0	1.9	53.4

# SINGLE-ROW TAPERED ROLLER BEARINGS (INCH DESIGN)

Bore Diameter 160~200 mm

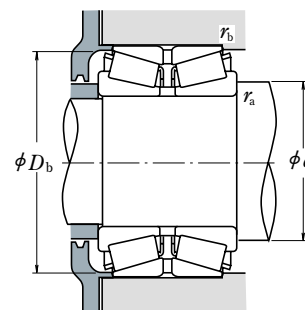
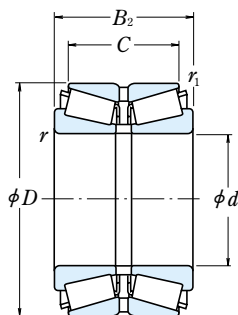

### Dynamic Equivalent Load

$$P = XF_r + YF_a$$

$F_a/F_r \leq e$		$F_a/F_r > e$	
X	Y	X	Y
1	$Y_3$	0.67	$Y_2$

### Static Equivalent Load

$$P_0 = F_r + Y_0 F_a$$

The values of  $e$ ,  $Y_2$ ,  $Y_3$ , and  $Y_0$  are given in the table below.

d	Boundary Dimensions (mm)					Basic Load Ratings (N)		Limiting Speeds (rpm)		
	D	B <sub>2</sub>	C	r <sub>min</sub>	r <sub>1 min</sub>	C <sub>r</sub>	C <sub>0r</sub>	Grease	Oil	
160	240	60	53	3	1	355 000	580 000	1 100	1 500	
	240	75	60	3	1	395 000	710 000	1 100	1 500	
	240	110	90	3	1	650 000	1 290 000	1 100	1 500	
	270	86	76	3	1	540 000	885 000	1 000	1 300	
	270	108	86	3	1	775 000	1 380 000	1 000	1 300	
	270	140	120	3	1	990 000	1 880 000	1 000	1 300	
	280	150	125	4	1	1 100 000	2 020 000	1 000	1 300	
	290	115	91	4	1	800 000	1 220 000	900	1 300	
	290	178	144	4	1	1 360 000	2 440 000	1 000	1 300	
	340	160	126	5	1.5	1 310 000	1 920 000	800	1 100	
165	290	150	125	4	1	1 140 000	2 130 000	900	1 300	
170	250	85	65	3	1	435 000	845 000	1 000	1 400	
	260	67	60	3	1	400 000	700 000	1 000	1 300	
	260	84	67	3	1	575 000	1 030 000	1 000	1 300	
	280	88	78	3	1	630 000	1 040 000	900	1 300	
	280	110	88	3	1	820 000	1 450 000	900	1 300	
	280	150	130	3	1	1 110 000	2 160 000	1 000	1 300	
	310	192	152	5	1.5	1 590 000	2 910 000	900	1 200	
	180	280	74	66	3	1	455 000	810 000	900	1 300
		280	93	74	3	1	655 000	1 220 000	900	1 200
		300	96	85	3	1	725 000	1 210 000	900	1 200
300		120	96	4	1.5	940 000	1 690 000	900	1 200	
320		127	99	5	1.5	895 000	1 390 000	800	1 200	
320		192	152	5	1.5	1 640 000	3 050 000	900	1 200	
340		180	140	5	1.5	1 410 000	2 510 000	800	1 100	
190		290	75	67	3	1	490 000	845 000	900	1 200
		290	94	75	3	1	670 000	1 230 000	900	1 200
		320	104	92	4	1.5	800 000	1 380 000	800	1 100
	320	130	104	4	1.5	1 070 000	1 960 000	800	1 100	
	340	133	105	5	1.5	990 000	1 580 000	800	1 100	
	340	204	160	5	1.5	1 910 000	3 550 000	800	1 100	
200	310	152	123	3	1	1 300 000	2 740 000	800	1 100	
	320	146	110	5	1.5	990 000	2 120 000	800	1 100	
	330	180	140	5	1.5	1 390 000	2 730 000	800	1 100	
	340	112	100	4	1.5	940 000	1 670 000	800	1 000	
	340	140	112	4	1.5	1 260 000	2 250 000	800	1 000	
	360	142	110	5	1.5	1 100 000	1 780 000	700	1 000	
	360	218	174	5	1.5	2 070 000	3 850 000	800	1 000	

Bearing Numbers	Abutment and Fillet Dimensions (mm)				Constant e	Axial Load Factors			Mass (kg) approx
	d <sub>a min</sub>	D <sub>b min</sub>	r <sub>a max</sub>	r <sub>b max</sub>		Y <sub>2</sub>	Y <sub>3</sub>	Y <sub>0</sub>	
160 KBE 30+L	178	231	2.5	1	0.37	2.7	1.8	1.8	8.56
160 KBE 030+L	178	230	2.5	1	0.40	2.5	1.7	1.6	10.5
160 KBE 2401+L	178	232	2.5	1	0.38	2.6	1.8	1.7	16.2
160 KBE 31+L	178	255	2.5	1	0.40	2.5	1.7	1.6	18.6
160 KBE 031+L	178	256	2.5	1	0.39	2.6	1.7	1.7	23.1
160 KBE 2701+L	178	261	2.5	1	0.39	2.6	1.7	1.7	30.6
160 KBE 2801+L	181	266	3	1	0.32	3.2	2.1	2.1	35.9
160 KBE 42+L	181	275	3	1	0.43	2.3	1.6	1.5	28.2
HR160 KBE 52X+L	181	277	3	1	0.44	2.3	1.6	1.5	47.3
160 KBE 43+L	187	314	4	1.5	0.36	2.8	1.9	1.8	60.4
165 KBE 2901+L	186	272	3	1	0.33	3.1	2.1	2.0	39.5
170 KBE 2501+L	188	241	2.5	1	0.44	2.3	1.5	1.5	12.3
170 KBE 30+L	188	248	2.5	1	0.40	2.5	1.7	1.6	11.8
170 KBE 030+L	188	249	2.5	1	0.39	2.6	1.7	1.7	14.4
170 KBE 31+L	188	266	2.5	1	0.39	2.6	1.7	1.7	19.7
170 KBE 031+L	188	268	2.5	1	0.39	2.6	1.7	1.7	24.2
170 KBE 2802+L	188	269	2.5	1	0.39	2.6	1.7	1.7	34.6
HR170 KBE 52X+L	197	297	4	1.5	0.44	2.3	1.6	1.5	57.3
180 KBE 30+L	198	265	2.5	1	0.40	2.5	1.7	1.6	15.4
180 KBE 030+L	198	265	2.5	1	0.35	2.9	2.0	1.9	14.4
180 KBE 31+L	198	265	2.5	1	0.39	2.6	1.7	1.7	24.8
180 KBE 031+L	201	287	3	1.5	0.39	2.6	1.7	1.7	31.1
180 KBE 42+L	207	300	4	1.5	0.44	2.3	1.5	1.5	36.5
HR180 KBE 52X+L	207	308	4	1.5	0.45	2.2	1.5	1.5	59.2
180 KBE 3401+L	207	305	4	1.5	0.43	2.3	1.6	1.5	68.1
190 KBE 30+L	208	279	2.5	1	0.39	2.6	1.7	1.7	16.2
190 KBE 030+L	208	279	2.5	1	0.40	2.5	1.7	1.6	20.1
190 KBE 31+L	211	301	3	1.5	0.40	2.5	1.7	1.6	30.9
190 KBE 031+L	211	302	3	1.5	0.39	2.6	1.7	1.7	39.0
190 KBE 42+L	217	320	4	1.5	0.40	2.5	1.7	1.6	43.9
HR190 KBE 52X+L	217	327	4	1.5	0.44	2.3	1.6	1.5	70.8
HR200 KBE 3101+L	218	301	2.5	1	0.43	2.3	1.6	1.5	40.1
200 KBE 3201+L	227	301	4	1.5	0.52	1.9	1.3	1.3	41.6
200 KBE 3301+L	227	316	4	1.5	0.42	2.4	1.6	1.6	54.4
200 KBE 31+L	221	321	3	1.5	0.40	2.5	1.7	1.6	38.8
200 KBE 031+L	221	324	3	1.5	0.39	2.6	1.7	1.7	47.0
200 KBE 42+L	227	338	4	1.5	0.40	2.5	1.7	1.6	52.6
HR200 KBE 52+L	227	344	4	1.5	0.41	2.5	1.7	1.6	88.3

Remarks For other double-row tapered roller bearings not listed above, please contact NSK.

# SINGLE-ROW TAPERED ROLLER BEARINGS (INCH DESIGN)

Bore Diameter 206~260 mm

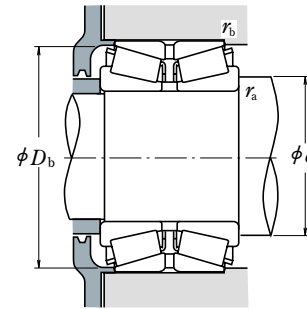
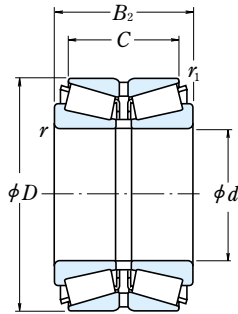

### Dynamic Equivalent Load

$$P = XF_r + YF_a$$

$F_a/F_r \leq e$		$F_a/F_r > e$	
X	Y	X	Y
1	$Y_3$	0.67	$Y_2$

### Static Equivalent Load

$$P_0 = F_r + Y_0 F_a$$

The values of  $e$ ,  $Y_2$ ,  $Y_3$ , and  $Y_0$  are given in the table below.

$d$	Boundary Dimensions (mm)					Basic Load Ratings (N)		Limiting Speeds (rpm)	
	$D$	$B_2$	$C$	$r_{\min}$	$r_{1\min}$	$C_r$	$C_{0r}$	Grease	Oil
<b>206</b>	283	102	83	4	1.5	580 000	1 430 000	900	1 200
<b>210</b>	355	116	103	4	1.5	905 000	1 520 000	700	1 000
<b>220</b>	300	110	88	3	1	730 000	1 710 000	800	1 100
	340	90	80	4	1.5	695 000	1 280 000	700	1 000
	340	113	90	4	1.5	920 000	1 830 000	700	1 000
<b>240</b>	370	120	107	5	1.5	1 110 000	1 940 000	700	1 000
	370	150	120	5	1.5	1 460 000	2 760 000	700	1 000
	400	158	122	5	1.5	1 390 000	2 300 000	600	900
<b>250</b>	360	92	82	4	1.5	780 000	1 490 000	700	900
	360	115	92	4	1.5	1 020 000	2 040 000	700	900
	400	128	114	5	1.5	1 180 000	2 190 000	600	900
<b>260</b>	400	160	128	5	1.5	1 620 000	3 050 000	600	900
	400	209	168	5	1.5	2 220 000	4 450 000	600	900
	380	98	87	4	1	795 000	1 460 000	600	900
<b>260</b>	400	104	92	5	1.5	895 000	1 670 000	600	800
	400	130	104	5	1.5	1 210 000	2 460 000	600	800
	440	144	128	5	1.5	1 540 000	2 760 000	600	800
	440	172	145	5	1.5	1 870 000	3 500 000	600	800
	440	180	144	5	1.5	2 110 000	4 150 000	600	800

**Remarks** For other double-row tapered roller bearings not listed above, please contact NSK.

Bearing Numbers	Abutment and Fillet Dimensions (mm)				Constant $e$	Axial Load Factors			Mass (kg) approx
	$d_{a\min}$	$D_{b\min}$	$r_{a\max}$	$r_{b\max}$		$Y_2$	$Y_3$	$Y_0$	
<b>206 KBE 2801+L</b>	227	275	3	1.5	0.51	2.0	1.3	1.3	18.1
<b>210 KBE 31+L</b>	231	338	3	1.5	0.46	2.2	1.5	1.4	41.7
<b>220 KBE 3001+L</b>	238	292	2.5	1	0.37	2.7	1.8	1.8	21.2
<b>220 KBE 30+L</b>	241	324	3	1.5	0.40	2.5	1.7	1.6	27.9
<b>220 KBE 030+L</b>	241	327	3	1.5	0.40	2.5	1.7	1.6	34.7
<b>220 KBE 31+L</b>	247	345	4	1.5	0.39	2.6	1.7	1.7	48.3
<b>220 KBE 031+L</b>	247	349	4	1.5	0.39	2.6	1.7	1.7	60.2
<b>220 KBE 42+L</b>	247	371	4	1.5	0.40	2.5	1.7	1.6	74.2
<b>240 KBE 30+L</b>	261	344	3	1.5	0.39	2.6	1.7	1.7	30.1
<b>240 KBE 030+L</b>	261	344	3	1.5	0.35	2.9	2.0	1.9	37.3
<b>240 KBE 31+L</b>	267	380	4	1.5	0.43	2.3	1.6	1.5	60.0
<b>240 KBE 031+L</b>	267	378	4	1.5	0.39	2.6	1.7	1.7	73.6
<b>240 KBE 4003+L</b>	267	384	4	1.5	0.33	3.0	2.0	2.0	96.4
<b>250 KBE 3801+L</b>	271	365	3	1	0.40	2.5	1.7	1.6	35.5
<b>260 KBE 30+L</b>	287	379	4	1.5	0.40	2.5	1.7	1.6	43.4
<b>260 KBE 030+L</b>	287	382	4	1.5	0.40	2.5	1.7	1.6	54.1
<b>260 KBE 31+L</b>	287	416	4	1.5	0.39	2.6	1.7	1.7	82.5
<b>260 KBE 4401+L</b>	287	414	4	1.5	0.38	2.6	1.8	1.7	98.1
<b>260 KBE 031+L</b>	287	416	4	1.5	0.39	2.6	1.7	1.7	104.0





Bore Diameter 20~55 mm

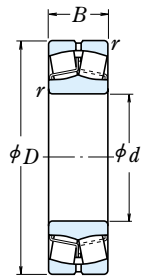

Cylindrical Bore

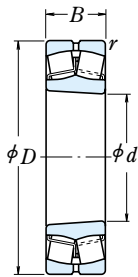

Tapered Bore

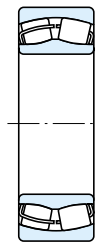

Without an Oil Groove or Holes

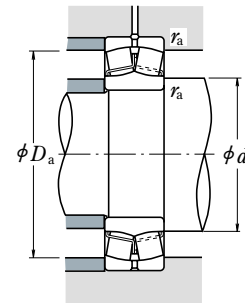

**Dynamic Equivalent Load**

$$P = XF_r + YF_a$$

$F_a/F_r \leq e$		$F_a/F_r > e$	
X	Y	X	Y
1	$Y_3$	0.67	$Y_2$

**Static Equivalent Load**

$$P_0 = F_r + Y_0 F_a$$

The values of  $e$ ,  $Y_2$ ,  $Y_3$ , and  $Y_0$  are given in the table below.

Boundary Dimensions (mm)				Basic Load Ratings				Limiting Speeds (rpm)		Bearing
$d$	$D$	$B$	$r_{min}$	$C_r$ (N)	$C_{0r}$	$\{kgf\}$		Grease	Oil	
20	52	15	1.1	29 300	26 900	2 980	2 740	6 300	8 200	<b>21304CDE4</b>
25	52	18	1	37 500	37 000	3 850	3 800	7 100	9 000	<b>22205CE4</b>
	62	17	1.1	43 000	40 500	4 350	4 150	5 300	6 700	<b>21305CDE4</b>
30	62	20	1	50 000	50 000	5 100	5 100	6 000	7 500	<b>22206CE4</b>
	72	19	1.1	55 000	54 000	5 600	5 500	4 500	6 000	<b>21306CDE4</b>
35	72	23	1.1	69 000	71 000	7 050	7 200	5 300	6 700	<b>22207CE4</b>
	80	21	1.5	71 500	76 000	7 250	7 750	4 000	5 300	<b>21307CDE4</b>
40	80	23	1.1	90 500	99 500	9 200	10 100	6 000	7 500	<b>22208EAE4</b>
	90	23	1.5	94 500	111 000	9 600	11 300	5 300	7 000	<b>21308EAE4</b>
	90	33	1.5	136 000	153 000	13 900	15 600	4 500	6 000	<b>22308EAE4</b>
45	85	23	1.1	94 500	111 000	9 600	11 300	5 300	7 000	<b>22209EAE4</b>
	100	25	1.5	119 000	144 000	12 100	14 600	4 500	5 600	<b>21309EAE4</b>
	100	36	1.5	166 000	195 000	16 900	19 900	4 000	5 300	<b>22309EAE4</b>
50	90	23	1.1	99 000	119 000	10 100	12 100	5 000	6 300	<b>22210EAE4</b>
	110	27	2	142 000	174 000	14 500	17 800	4 300	5 300	<b>21310EAE4</b>
	110	40	2	197 000	234 000	20 000	23 900	3 800	4 800	<b>22310EAE4</b>
55	100	25	1.5	119 000	144 000	12 100	14 600	4 500	5 600	<b>22211EAE4</b>
	120	29	2	142 000	174 000	14 500	17 800	4 300	5 300	<b>21311EAE4</b>
	120	43	2	234 000	292 000	23 800	29 800	3 400	4 300	<b>22311EAE4</b>

**Note** (1) The suffix K represents bearings with tapered bores (taper 1 : 12).

Numbers	Abutment and Fillet Dimensions (mm)					Constant	Axial Load Factors			Mass (kg)
	$d_a$		$D_a$		$r_a$		$e$	$Y_2$	$Y_3$	
Tapered Bore <sup>(1)</sup>	min	max	max	min	max					approx
<b>21304CDKE4</b>	27	28	45	42	1	0.31	3.2	2.1	2.1	0.17
<b>22205CKE4</b> <b>21305CDKE4</b>	31	31	46	45	1	0.35	2.9	1.9	1.9	0.17
	32	34	55	51	1	0.29	3.4	2.3	2.3	0.26
<b>22206CKE4</b> <b>21306CDKE4</b>	36	37	56	54	1	0.33	3.1	2.1	2.0	0.27
	37	40	65	59	1	0.28	3.6	2.4	2.3	0.39
<b>22207CKE4</b> <b>21307CDKE4</b>	42	43	65	63	1	0.32	3.1	2.1	2.0	0.42
	44	47	71	67	1.5	0.28	3.6	2.4	2.4	0.53
<b>22208EAKE4</b> <b>21308EAKE4</b> <b>22308EAKE4</b>	47	49	73	70	1	0.28	3.6	2.4	2.4	0.50
	49	54	81	75	1.5	0.25	3.9	2.7	2.6	0.73
	49	52	81	77	1.5	0.35	2.8	1.9	1.9	0.98
<b>22209EAKE4</b> <b>21309EAKE4</b> <b>22309EAKE4</b>	52	54	78	75	1	0.25	3.9	2.7	2.6	0.55
	54	65	91	89	1.5	0.23	4.3	2.9	2.8	0.96
	54	59	91	86	1.5	0.34	2.9	2.0	1.9	1.34
<b>22210EAKE4</b> <b>21310EAKE4</b> <b>22310EAKE4</b>	57	60	83	81	1	0.24	4.3	2.9	2.8	0.61
	60	72	100	98	2	0.23	4.4	3.0	2.9	1.21
	60	64	100	93	2	0.35	2.8	1.9	1.9	1.78
<b>22211EAKE4</b> <b>21311EAKE4</b> <b>22311EAKE4</b>	64	65	91	89	1.5	0.23	4.3	2.9	2.8	0.81
	65	72	110	98	2	0.23	4.4	3.0	2.9	1.58
	65	73	110	103	2	0.34	2.9	2.0	1.9	2.3

**Remarks** 1. An oil groove and holes are standard for the EA type.  
2. For the dimensions of adapters and withdrawal sleeves, refer to Pages **B354**, **B355**, and **B362**.

Bore Diameter 60~85 mm

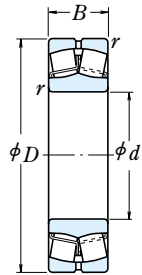

Cylindrical Bore

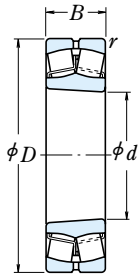

Tapered Bore

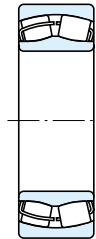

Without an Oil Groove or Holes

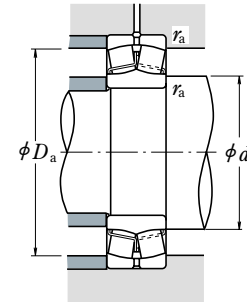

**Dynamic Equivalent Load**

$$P = XF_r + YF_a$$

$F_a/F_r \leq e$		$F_a/F_r > e$	
X	Y	X	Y
1	$Y_3$	0.67	$Y_2$

**Static Equivalent Load**

$$P_0 = F_r + Y_0 F_a$$

The values of  $e$ ,  $Y_2$ ,  $Y_3$ , and  $Y_0$  are given in the table below.

Boundary Dimensions (mm)	Basic Load Ratings				Limiting Speeds (rpm)		Bearing				
	$d$	$D$	$B$	$r_{min}$	$C_r$	$C_{0r}$		$C_r$	$C_{0r}$	Grease	Oil
<b>60</b>	95	26	1.1		98 000	141 000	10 000	14 400	3 600	4 500	<b>23012CE4</b> <b>22212EAE4</b> <b>21312EAE4</b> <b>22312EAE4</b>
	110	28	1.5		142 000	174 000	14 500	17 800	4 300	5 300	
	130	31	2.1		190 000	244 000	19 400	24 900	3 400	4 300	
	130	46	2.1		271 000	340 000	27 600	35 000	3 200	4 000	
<b>65</b>	120	31	1.5		177 000	230 000	18 000	23 500	3 800	4 800	<b>22213EAE4</b> <b>21313EAE4</b> <b>22313EAE4</b>
	140	33	2.1		212 000	275 000	21 600	28 000	3 200	4 000	
	140	48	2.1		300 000	380 000	30 500	38 500	3 000	3 800	
<b>70</b>	125	31	1.5		180 000	232 000	18 300	23 600	3 600	4 500	<b>22214EAE4</b> <b>21314EAE4</b> <b>22314EAE4</b>
	150	35	2.1		250 000	325 000	25 400	33 500	3 000	3 800	
	150	51	2.1		340 000	435 000	34 500	44 000	2 800	3 400	
<b>75</b>	130	31	1.5		190 000	244 000	19 400	24 900	3 400	4 300	<b>22215EAE4</b> <b>21315EAE4</b> <b>22315EAE4</b>
	160	37	2.1		250 000	325 000	25 400	33 500	3 000	3 800	
	160	55	2.1		390 000	505 000	39 500	51 500	2 600	3 200	
<b>80</b>	140	33	2		212 000	275 000	21 600	28 000	3 200	4 000	<b>22216EAE4</b> <b>21316EAE4</b> <b>22316EAE4</b>
	170	39	2.1		284 000	375 000	29 000	38 000	2 800	3 600	
	170	58	2.1		435 000	565 000	44 000	58 000	2 400	3 000	
<b>85</b>	150	36	2		250 000	325 000	25 400	33 500	3 000	3 800	<b>22217EAE4</b> <b>21317EAE4</b> <b>22317EAE4</b>
	180	41	3		289 000	395 000	29 500	40 000	2 800	3 600	
	180	60	3		480 000	630 000	49 000	64 000	2 200	2 800	

**Note** (1) The suffix K represents bearings with tapered bores (taper 1 : 12).

Numbers	Abutment and Fillet Dimensions (mm)					Constant	Axial Load Factors			Mass (kg)
	Tapered Bore <sup>(1)</sup>		$d_a$	$D_a$	$r_a$		$e$	$Y_2$	$Y_3$	
<b>23012CKE4</b> <b>22212EAKE4</b> <b>21312EAKE4</b> <b>22312EAKE4</b>	min	max	max	min	max	0.26 0.23 0.22 0.34	3.9 4.4 4.5 3.0	2.6 3.0 3.0 2.0	2.5 2.9 3.0 1.9	0.68 1.1 1.98 2.89
	67	68	88	85	1					
	69	72	101	98	1.5					
	72	87	118	117	2					
<b>22213EAKE4</b> <b>21313EAKE4</b> <b>22313EAKE4</b>	min	max	max	min	max	0.24 0.22 0.33	4.2 4.6 3.0	2.8 3.1 2.0	2.7 3.0 2.0	1.51 2.45 3.52
	74	80	111	107	1.5					
	77	94	128	126	2					
	77	84	128	119	2					
<b>22214EAKE4</b> <b>21314EAKE4</b> <b>22314EAKE4</b>	min	max	max	min	max	0.23 0.22 0.33	4.3 4.6 3.0	2.9 3.1 2.0	2.8 3.0 2.0	1.58 3.0 4.28
	79	84	116	111	1.5					
	82	101	138	135	2					
	82	91	138	129	2					
<b>22215EAKE4</b> <b>21315EAKE4</b> <b>22315EAKE4</b>	min	max	max	min	max	0.22 0.22 0.33	4.5 4.6 3.0	3.0 3.1 2.0	3.0 3.0 2.0	1.64 3.64 5.26
	84	87	121	117	1.5					
	87	101	148	134	2					
	87	97	148	137	2					
<b>22216EAKE4</b> <b>21316EAKE4</b> <b>22316EAKE4</b>	min	max	max	min	max	0.22 0.23 0.33	4.6 4.4 3.0	3.1 3.0 2.0	3.0 2.9 2.0	2.01 4.32 6.23
	90	94	130	126	2					
	92	109	158	146	2					
	92	103	158	145	2					
<b>22217EAKE4</b> <b>21317EAKE4</b> <b>22317EAKE4</b>	min	max	max	min	max	0.22 0.24 0.33	4.6 4.3 3.1	3.1 2.9 2.1	3.0 2.8 2.0	2.54 5.2 7.23
	95	101	140	135	2					
	99	108	166	142	2.5					
	99	110	166	155	2.5					

**Remarks** 1. An oil groove and holes are standard for the EA type.  
2. For the dimensions of adapters and withdrawal sleeves, refer to Pages **B355**, **B357**, and **B362**.

Bore Diameter 90~110 mm

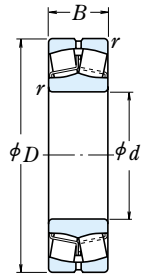

Cylindrical Bore

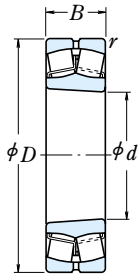

Tapered Bore

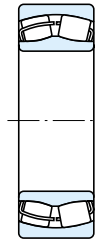

Without an Oil Groove or Holes

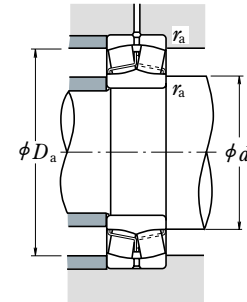

**Dynamic Equivalent Load**

$$P = X F_r + Y F_a$$

$F_a/F_r \leq e$		$F_a/F_r > e$	
X	Y	X	Y
1	$Y_3$	0.67	$Y_2$

**Static Equivalent Load**

$$P_0 = F_r + Y_0 F_a$$

The values of  $e$ ,  $Y_2$ ,  $Y_3$ , and  $Y_0$  are given in the table below.

Boundary Dimensions (mm)	Basic Load Ratings				Limiting Speeds (rpm)		Bearing		
	$d$	$D$	$B$	$r_{min}$	$C_r$ (N)	$C_{0r}$ (kgf)		Grease	Oil
<b>90</b>	160	40	2		289 000	395 000	29 500	40 000	<b>22218EAE4</b>
	160	52.4	2		340 000	490 000	34 500	50 000	<b>23218CE4</b>
	190	43	3		330 000	450 000	33 500	46 000	<b>21318EAE4</b>
	190	64	3		535 000	705 000	54 500	72 000	<b>22318EAE4</b>
<b>95</b>	170	43	2.1		330 000	450 000	33 500	46 000	<b>22219EAE4</b>
	170	55.6	2.1		370 000	525 000	37 500	53 500	<b>23219CAE4</b>
	200	45	3		345 000	435 000	35 000	44 500	<b>21319CE4</b>
	200	67	3		590 000	780 000	60 000	79 500	<b>22319EAE4</b>
<b>100</b>	150	37	1.5		212 000	335 000	21 600	34 500	<b>23020CDE4</b>
	150	50	1.5		276 000	470 000	28 100	48 000	<b>24020CE4</b>
	165	52	2		345 000	530 000	35 500	54 000	<b>23120CE4</b>
	165	65	2		345 000	535 000	35 000	55 000	<b>24120CAE4</b>
	180	46	2.1		365 000	490 000	37 000	50 000	<b>22220EAE4</b>
	180	60.3	2.1		420 000	605 000	42 500	61 500	<b>23220CE4</b>
	215	47	3		395 000	485 000	40 500	49 500	<b>21320CE4</b>
	215	73	3		690 000	930 000	70 500	94 500	<b>22320EAE4</b>
<b>110</b>	170	45	2		293 000	465 000	29 900	47 500	<b>23022CDE4</b>
	170	60	2		380 000	645 000	38 500	66 000	<b>24022CE4</b>
	180	56	2		385 000	630 000	39 500	64 000	<b>23122CE4</b>
	180	69	2		460 000	750 000	47 000	76 500	<b>24122CE4</b>
	200	53	2.1		485 000	645 000	49 500	66 000	<b>22222EAE4</b>
	200	69.8	2.1		515 000	760 000	52 500	77 500	<b>23222CE4</b>
	240	50	3		450 000	545 000	46 000	55 500	<b>21322CAE4</b>
	240	80	3		825 000	1 120 000	84 000	115 000	<b>22322EAE4</b>

**Note** (1) The suffix K or K30 represents bearings with tapered bores (taper 1 : 12 or 1 : 30).

Numbers	Abutment and Fillet Dimensions (mm)					Constant	Axial Load Factors			Mass (kg)
	Tapered Bore(1)		$d_a$	$D_a$	$r_a$		$e$	$Y_2$	$Y_3$	
<b>22218EAKE4</b> <b>23218CKE4</b> <b>21318EAKE4</b> <b>22318EAKE4</b>	min	max	max	min	max	0.24 0.32 0.24 0.33	4.3 3.2 4.3 3.1	2.9 2.1 2.9 2.1	2.8 2.1 2.8 2.0	3.3 4.51 6.1 8.56
	100	108	150	142	2					
	100	105	150	138	2					
	104	115	176	152	2.5					
<b>22219EAKE4</b> <b>23219CAKE4</b> <b>21319CKE4</b> <b>22319EAKE4</b>	min	max	max	min	max	0.24 0.32 0.22 0.33	4.3 3.1 4.6 3.1	2.9 2.1 3.1 2.1	2.8 2.0 3.0 2.0	4.04 5.33 6.92 9.91
	107	115	158	152	2					
	107	—	158	146	2					
	109	127	186	172	2.5					
<b>23020CDKE4</b> <b>24020CK30E4</b> <b>23120CKE4</b>	min	max	max	min	max	0.22 0.30 0.30	4.6 3.4 3.4	3.1 2.3 2.3	3.0 2.2 2.2	2.31 3.08 4.38
	109	112	141	136	1.5					
	109	110	141	132	1.5					
	110	113	155	144	2					
<b>24120CAK30E4</b> <b>22220EAKE4</b> <b>23220CKE4</b>	min	max	max	min	max	0.35 0.24 0.32	2.9 4.3 3.2	1.9 2.9 2.1	1.9 2.8 2.1	5.42 4.84 6.6
	110	—	155	143	2					
	112	119	168	160	2					
<b>21320CKE4</b> <b>22320EAKE4</b>	min	max	max	min	max	0.21 0.33	4.7 3.0	3.2 2.0	3.1 2.0	8.46 12.7
	114	133	201	184	2.5					
<b>23022CDKE4</b> <b>24022CK30E4</b> <b>23122CKE4</b>	min	max	max	min	max	0.24 0.32 0.28	4.2 3.1 3.5	2.8 2.1 2.4	2.8 2.1 2.3	3.76 4.96 5.7
	120	124	160	153	2					
	120	121	160	148	2					
	120	127	170	158	2					
<b>24122CK30E4</b> <b>22222EAKE4</b> <b>23222CKE4</b>	min	max	max	min	max	0.36 0.25 0.34	2.8 4.0 3.0	1.9 2.7 2.0	1.8 2.6 1.9	6.84 6.99 9.54
	120	123	170	154	2					
	122	129	188	178	2					
<b>21322CAKE4</b> <b>22322EAKE4</b>	min	max	max	min	max	0.22 0.33	4.6 3.1	3.1 2.1	3.0 2.0	11.2 17.6
	124	—	226	206	2.5					
	124	145	226	206	2.5					

**Remarks** 1. An oil groove and holes are standard for the EA type.  
2. For the dimensions of adapters and withdrawal sleeves, refer to Pages **B356**, **B357**, and **B362**, **B363**.

Bore Diameter 120~150 mm

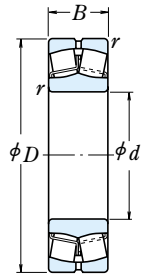

Cylindrical Bore

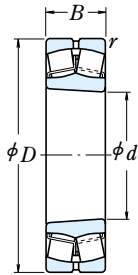

Tapered Bore

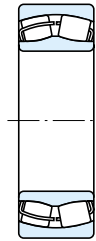

Without an Oil Groove or Holes

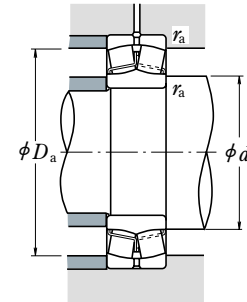

**Dynamic Equivalent Load**

$$P = XF_r + YF_a$$

$F_a/F_r \leq e$		$F_a/F_r > e$	
X	Y	X	Y
1	$Y_3$	0.67	$Y_2$

**Static Equivalent Load**

$$P_0 = F_r + Y_0 F_a$$

The values of  $e$ ,  $Y_2$ ,  $Y_3$ , and  $Y_0$  are given in the table below.

Boundary Dimensions (mm)	Basic Load Ratings				Limiting Speeds (rpm)		Bearing				
	$d$	$D$	$B$	$r_{min}$	(N)	(kgf)		Grease	Oil	Cylindrical Bore	
					$C_r$	$C_{0r}$					
<b>120</b>	180	46	2		315 000	525 000	32 000	53 500	1 800	2 200	<b>23024CDE4</b> <b>24024CE4</b> <b>23124CE4</b>
	180	60	2		395 000	705 000	40 500	72 000	1 500	2 000	
	200	62	2		465 000	720 000	47 500	73 500	1 400	1 800	
	200	80	2		575 000	950 000	58 500	96 500	1 400	1 800	<b>24124CE4</b> <b>22224EAE4</b> <b>23224CE4</b> <b>22324EAE4</b>
	215	58	2.1		550 000	765 000	56 000	78 000	2 000	2 600	
	215	76	2.1		630 000	970 000	64 500	99 000	1 300	1 700	
260	86	3		955 000	1 320 000	97 000	134 000	1 600	2 000		
<b>130</b>	200	52	2		400 000	655 000	40 500	67 000	1 700	2 000	<b>23026CDE4</b> <b>24026CE4</b> <b>23126CE4</b>
	200	69	2		495 000	865 000	50 500	88 000	1 400	1 800	
	210	64	2		505 000	825 000	51 500	84 500	1 300	1 700	
	210	80	2		590 000	1 010 000	60 000	103 000	1 300	1 700	<b>24126CE4</b> <b>22226EAE4</b> <b>23226CE4</b> <b>22326CE4</b>
	230	64	3		655 000	940 000	67 000	96 000	1 900	2 400	
	230	80	3		700 000	1 080 000	71 500	110 000	1 200	1 600	
280	93	4		995 000	1 350 000	101 000	137 000	1 300	1 600		
<b>140</b>	210	53	2		420 000	715 000	43 000	73 000	1 600	1 900	<b>23028CDE4</b> <b>24028CE4</b> <b>23128CE4</b>
	210	69	2		525 000	945 000	53 500	96 500	1 300	1 700	
	225	68	2.1		580 000	945 000	59 000	96 500	1 200	1 600	
	225	85	2.1		670 000	1 160 000	68 500	118 000	1 200	1 600	<b>24128CE4</b> <b>22228CDE4</b> <b>23228CE4</b> <b>22328CE4</b>
	250	68	3		645 000	930 000	65 500	95 000	1 400	1 700	
	250	88	3		835 000	1 300 000	85 000	133 000	1 100	1 500	
300	102	4		1 160 000	1 590 000	118 000	162 000	1 200	1 500		
<b>150</b>	225	56	2.1		470 000	815 000	48 000	83 000	1 400	1 800	<b>23030CDE4</b> <b>24030CE4</b> <b>23130CE4</b>
	225	75	2.1		590 000	1 090 000	60 500	111 000	1 200	1 500	
	250	80	2.1		725 000	1 180 000	74 000	121 000	1 100	1 400	
	250	100	2.1		890 000	1 530 000	91 000	156 000	1 100	1 400	<b>24130CE4</b> <b>22230CDE4</b> <b>23230CE4</b> <b>22330CAE4</b>
	270	73	3		765 000	1 120 000	78 000	114 000	1 300	1 600	
	270	96	3		975 000	1 560 000	99 500	159 000	1 100	1 400	
320	108	4		1 220 000	1 690 000	125 000	172 000	1 100	1 400		

**Note** (1) The suffix K or K30 represents bearings with tapered bores (taper 1 : 12 or 1 : 30).

Numbers	Abutment and Fillet Dimensions (mm)					Constant	Axial Load Factors			Mass (kg)	
	Tapered Bore(1)	$d_a$	$D_a$	$r_a$	$e$		$Y_2$	$Y_3$	$Y_0$		approx
		min	max	max	min	max					
<b>23024CDKE4</b> <b>24024CK30E4</b> <b>23124CKE4</b>		130	134	170	163	2	0.22	4.5	3.0	2.9	4.11
		130	131	170	158	2	0.32	3.2	2.1	2.1	5.33
		130	138	190	175	2	0.29	3.5	2.4	2.3	7.85
<b>24124CK30E4</b> <b>22224EAKE4</b> <b>23224CKE4</b> <b>22324EAKE4</b>		130	136	190	171	2	0.37	2.7	1.8	1.8	10
		132	142	203	190	2	0.25	3.9	2.7	2.6	8.8
		132	140	203	182	2	0.34	2.9	2.0	1.9	12.1
		134	157	246	222	2.5	0.32	3.1	2.1	2.0	22.2
<b>23026CDKE4</b> <b>24026CK30E4</b> <b>23126CKE4</b>		140	147	190	180	2	0.23	4.3	2.9	2.8	5.98
		140	143	190	175	2	0.31	3.2	2.2	2.1	7.84
		140	149	200	184	2	0.28	3.6	2.4	2.4	8.69
<b>24126CK30E4</b> <b>22226EAKE4</b> <b>23226CKE4</b> <b>22326CKE4</b>		140	146	200	180	2	0.35	2.9	1.9	1.9	10.7
		144	152	216	204	2.5	0.26	3.8	2.6	2.5	11
		144	150	216	196	2.5	0.34	2.9	2.0	1.9	14.3
		148	166	262	236	3	0.34	2.9	2.0	1.9	28.1
<b>23028CDKE4</b> <b>24028CK30E4</b> <b>23128CKE4</b>		150	157	200	190	2	0.22	4.5	3.0	2.9	6.49
		150	154	200	186	2	0.29	3.4	2.3	2.2	8.37
		152	158	213	198	2	0.28	3.6	2.4	2.3	10.5
<b>24128CK30E4</b> <b>22228CDKE4</b> <b>23228CKE4</b> <b>22328CKE4</b>		152	156	213	193	2	0.35	2.9	1.9	1.9	13
		154	167	236	219	2.5	0.25	4.0	2.7	2.6	14.5
		154	163	236	213	2.5	0.35	2.9	1.9	1.9	18.8
		158	177	282	253	3	0.35	2.9	1.9	1.9	35.4
<b>23030CDKE4</b> <b>24030CK30E4</b> <b>23130CKE4</b>		162	168	213	203	2	0.22	4.6	3.1	3.0	7.9
		162	165	213	198	2	0.30	3.4	2.3	2.2	10.5
		162	174	238	218	2	0.30	3.4	2.3	2.2	15.8
<b>24130CK30E4</b> <b>22230CDKE4</b> <b>23230CKE4</b> <b>22330CAKE4</b>		162	169	238	212	2	0.38	2.6	1.8	1.7	19.8
		164	179	256	236	2.5	0.26	3.9	2.6	2.5	18.4
		164	176	256	230	2.5	0.35	2.9	1.9	1.9	24.2
		168	—	302	270	3	0.35	2.9	1.9	1.9	41.5

**Remarks** 1. An oil groove and holes are standard for the EA type.  
2. For the dimensions of adapters and withdrawal sleeves, refer to Pages **B357**, **B358**, **B349**, and **B363**, **B364**.

Bore Diameter 160~190 mm

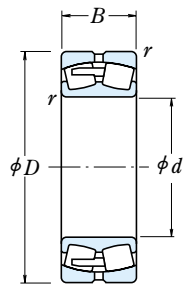

Cylindrical Bore

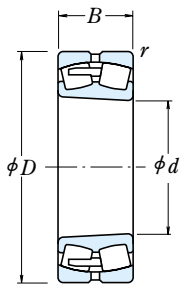

Tapered Bore

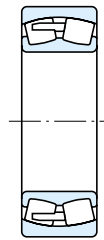

Without an Oil Groove and Holes

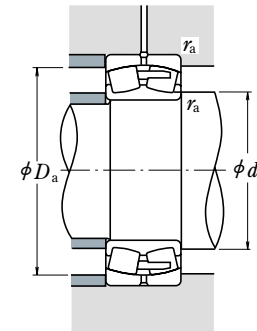

**Dynamic Equivalent Load**

$$P = XF_r + YF_a$$

$F_a/F_r \leq e$		$F_a/F_r > e$	
X	Y	X	Y
1	$Y_3$	0.67	$Y_2$

**Static Equivalent Load**

$$P_0 = F_r + Y_0 F_a$$

The values of  $e$ ,  $Y_2$ ,  $Y_3$ , and  $Y_0$  are given in the table below.

Boundary Dimensions (mm)	Basic Load Ratings				Limiting Speeds (rpm)		Bearing
	$C_r$	$C_{0r}$	$C_r$	$C_{0r}$	Grease	Oil	
$d$ $D$ $B$ $r_{min}$	(N)	(kgf)					Cylindrical Bore
<b>160</b>	220 45 2	360 000 675 000	37 000 69 000	1 400 1 800	<b>23932CAE4</b>		
	240 60 2.1	540 000 955 000	55 000 97 500	1 300 1 700	<b>23032CDE4</b>		
	240 80 2.1	680 000 1 260 000	69 000 128 000	1 100 1 400	<b>24032CE4</b>		
	270 86 2.1	855 000 1 400 000	87 000 143 000	1 000 1 300	<b>23132CE4</b>		
	270 109 2.1	1 040 000 1 760 000	106 000 179 000	1 000 1 300	<b>24132CE4</b>		
	290 80 3	910 000 1 320 000	93 000 135 000	1 200 1 500	<b>22232CDE4</b>		
	290 104 3	1 100 000 1 770 000	112 000 180 000	1 000 1 300	<b>23232CE4</b>		
	340 114 4	1 360 000 1 900 000	139 000 193 000	1 100 1 300	<b>22332CAE4</b>		
<b>170</b>	230 45 2	350 000 660 000	35 500 67 500	1 400 1 800	<b>23934BCAE4</b>		
	260 67 2.1	640 000 1 090 000	65 000 112 000	1 200 1 600	<b>23034CDE4</b>		
	260 90 2.1	825 000 1 520 000	84 000 155 000	1 000 1 300	<b>24034CE4</b>		
	280 88 2.1	940 000 1 570 000	96 000 160 000	1 000 1 300	<b>23134CE4</b>		
	280 109 2.1	1 080 000 1 860 000	110 000 190 000	1 000 1 300	<b>24134CE4</b>		
	310 86 4	990 000 1 500 000	101 000 153 000	1 100 1 400	<b>22234CDE4</b>		
	310 110 4	1 200 000 1 910 000	122 000 195 000	900 1 200	<b>23234CE4</b>		
	360 120 4	1 580 000 2 110 000	161 000 215 000	1 000 1 200	<b>22334CAE4</b>		
<b>180</b>	250 52 2	470 000 890 000	48 000 90 500	1 200 1 600	<b>23936CAE4</b>		
	280 74 2.1	750 000 1 270 000	76 000 129 000	1 200 1 400	<b>23036CDE4</b>		
	280 100 2.1	965 000 1 750 000	98 500 178 000	950 1 200	<b>24036CE4</b>		
	300 96 3	1 050 000 1 760 000	108 000 180 000	900 1 200	<b>23136CE4</b>		
	300 118 3	1 190 000 2 040 000	121 000 208 000	900 1 200	<b>24136CE4</b>		
	320 86 4	1 020 000 1 540 000	104 000 157 000	1 100 1 300	<b>22236CDE4</b>		
	320 112 4	1 300 000 2 110 000	133 000 215 000	850 1 100	<b>23236CE4</b>		
	380 126 4	1 740 000 2 340 000	177 000 238 000	950 1 200	<b>22336CAE4</b>		
<b>190</b>	260 52 2	460 000 875 000	47 000 89 500	1 200 1 500	<b>23938CAE4</b>		
	290 75 2.1	775 000 1 350 000	79 000 138 000	1 100 1 400	<b>23038CAE4</b>		
	290 100 2.1	975 000 1 840 000	99 500 188 000	900 1 200	<b>24038CE4</b>		
	320 104 3	1 190 000 2 020 000	121 000 206 000	850 1 100	<b>23138CE4</b>		
	320 128 3	1 370 000 2 330 000	140 000 238 000	850 1 100	<b>24138CE4</b>		
	340 92 4	1 140 000 1 730 000	116 000 176 000	1 000 1 200	<b>22238CAE4</b>		
	340 120 4	1 440 000 2 350 000	147 000 240 000	800 1 100	<b>23238CE4</b>		
	400 132 5	1 890 000 2 590 000	193 000 264 000	900 1 100	<b>22338CAE4</b>		

Note (1) The suffix K or K30 represents bearings with tapered bores (taper 1 : 12 or 1 : 30).

Numbers	Abutment and Fillet Dimensions (mm)					Constant	Axial Load Factors			Mass (kg)
	$d_a$	$D_a$	$r_a$	$e$	$Y_2$		$Y_3$	$Y_0$		
Tapered Bore(1)	min	max	max	min	max				approx	
<b>23932CAKE4</b>	170	—	210	203	2	0.18	5.6	3.8	3.7	4.97
<b>23032CDKE4</b>	172	179	228	216	2	0.22	4.5	3.0	2.9	9.66
<b>24032CK30E4</b>	172	177	228	212	2	0.30	3.4	2.3	2.2	12.7
<b>23132CKE4</b>	172	185	258	234	2	0.30	3.4	2.3	2.2	20.3
<b>24132CK30E4</b>	172	179	258	229	2	0.39	2.6	1.7	1.7	25.4
<b>22232CDKE4</b>	174	190	276	255	2.5	0.26	3.8	2.6	2.5	23.1
<b>23232CKE4</b>	174	189	276	245	2.5	0.34	2.9	2.0	1.9	30.5
<b>22332CAKE4</b>	178	—	322	287	3	0.35	2.9	1.9	1.9	49.3
<b>23934BCAKE4</b>	180	—	220	213	2	0.17	5.8	3.9	3.8	5.38
<b>23034CDKE4</b>	182	191	248	233	2	0.23	4.3	2.9	2.8	13
<b>24034CK30E4</b>	182	188	248	228	2	0.31	3.2	2.2	2.1	17.3
<b>23134CKE4</b>	182	194	268	245	2	0.29	3.5	2.3	2.3	21.8
<b>24134CK30E4</b>	182	190	268	239	2	0.37	2.7	1.8	1.8	26.6
<b>22234CDKE4</b>	188	206	292	270	3	0.26	3.8	2.6	2.5	28.8
<b>23234CKE4</b>	188	201	292	261	3	0.34	2.9	2.0	1.9	36.4
<b>22334CAKE4</b>	188	—	342	304	3	0.35	2.9	1.9	1.9	57.9
<b>23936CAKE4</b>	190	—	240	230	2	0.18	5.5	3.7	3.6	7.64
<b>23036CDKE4</b>	192	202	268	249	2	0.24	4.2	2.8	2.8	17.1
<b>24036CK30E4</b>	192	200	268	245	2	0.32	3.1	2.1	2.0	22.7
<b>23136CKE4</b>	194	206	286	260	2.5	0.30	3.4	2.3	2.2	27.5
<b>24136CK30E4</b>	194	202	286	255	2.5	0.37	2.7	1.8	1.8	33.1
<b>22236CDKE4</b>	198	212	302	278	3	0.26	3.9	2.6	2.6	30.2
<b>23236CKE4</b>	198	211	302	274	3	0.33	3.0	2.0	2.0	38.9
<b>22336CAKE4</b>	198	—	362	322	3	0.34	2.9	2.0	1.9	67
<b>23938CAKE4</b>	200	—	250	240	2	0.18	5.7	3.8	3.7	8.03
<b>23038CAKE4</b>	202	—	278	261	2	0.24	4.2	2.8	2.8	17.6
<b>24038CK30E4</b>	202	210	278	253	2	0.31	3.2	2.2	2.1	24
<b>23138CKE4</b>	204	219	306	276	2.5	0.31	3.3	2.2	2.2	34.5
<b>24138CK30E4</b>	204	211	306	269	2.5	0.40	2.5	1.7	1.6	41.5
<b>22238CAKE4</b>	208	—	322	296	3	0.26	3.8	2.6	2.5	35.5
<b>23238CKE4</b>	208	222	322	288	3	0.35	2.9	1.9	1.9	47.6
<b>22338CAKE4</b>	212	—	378	338	4	0.34	2.9	2.0	1.9	77.6

Remarks For the dimensions of adapters and withdrawal sleeves, refer to Pages B358 and B364.



Bore Diameter 200~260 mm

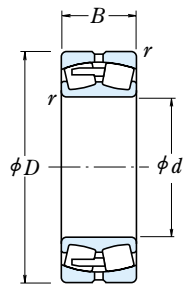

Cylindrical Bore

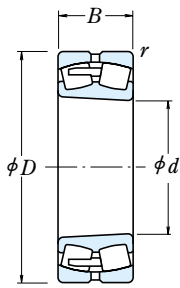

Tapered Bore



Without an Oil Groove and Holes

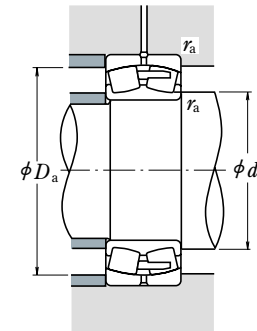

**Dynamic Equivalent Load**

$$P = XF_r + YF_a$$

$F_a/F_r \leq e$		$F_a/F_r > e$	
X	Y	X	Y
1	$Y_3$	0.67	$Y_2$

**Static Equivalent Load**

$$P_0 = F_r + Y_0 F_a$$

The values of  $e$ ,  $Y_2$ ,  $Y_3$ , and  $Y_0$  are given in the table below.

Boundary Dimensions (mm)	Basic Load Ratings				Limiting Speeds (rpm)		Bearing				
	$d$	$D$	$B$	$r_{min}$	(N)	{kgf}		Grease	Oil	Cylindrical Bore	
					$C_r$	$C_{0r}$	$C_r$	$C_{0r}$			
<b>200</b>	280	60	2.1	570 000	1 060 000	58 000	108 000	1 100	1 400	<b>23940CAE4</b>	
	310	82	2.1	940 000	1 700 000	96 000	174 000	1 000	1 300	<b>23040CAE4</b>	
	310	109	2.1	1 140 000	2 120 000	116 000	216 000	850	1 100	<b>24040CE4</b>	
	340	112	3	1 360 000	2 330 000	139 000	238 000	800	1 000	<b>23140CE4</b>	
	340	140	3	1 570 000	2 670 000	160 000	272 000	800	1 000	<b>24140CE4</b>	
	360	98	4	1 300 000	2 010 000	133 000	204 000	950	1 200	<b>22240CAE4</b>	
	360	128	4	1 660 000	2 750 000	169 000	281 000	750	1 000	<b>23240CE4</b>	
	420	138	5	2 000 000	2 990 000	204 000	305 000	850	1 000	<b>22340CAE4</b>	
	<b>220</b>	300	60	2.1	625 000	1 240 000	64 000	126 000	1 000	1 300	<b>23944CAE4</b>
		340	90	3	1 090 000	1 980 000	111 000	202 000	950	1 200	<b>23044CAE4</b>
340		118	3	1 360 000	2 600 000	138 000	265 000	750	1 000	<b>24044CE4</b>	
370		120	4	1 570 000	2 710 000	160 000	276 000	710	950	<b>23144CE4</b>	
370		150	4	1 800 000	3 200 000	183 000	325 000	710	950	<b>24144CE4</b>	
400		108	4	1 570 000	2 430 000	160 000	247 000	850	1 000	<b>22244CAE4</b>	
400		144	4	2 020 000	3 400 000	206 000	350 000	670	900	<b>23244CE4</b>	
460		145	5	2 350 000	3 400 000	240 000	345 000	750	950	<b>22344CAE4</b>	
<b>240</b>		320	60	2.1	635 000	1 300 000	65 000	133 000	950	1 200	<b>23948CAE4</b>
		360	92	3	1 160 000	2 140 000	118 000	218 000	850	1 100	<b>23048CAE4</b>
	360	118	3	1 390 000	2 730 000	141 000	278 000	710	950	<b>24048CE4</b>	
	400	128	4	1 790 000	3 100 000	182 000	320 000	670	850	<b>23148CE4</b>	
	400	160	4	2 130 000	3 800 000	217 000	385 000	670	850	<b>24148CE4</b>	
	440	120	4	1 870 000	2 890 000	191 000	294 000	750	950	<b>22248CAE4</b>	
	440	160	4	2 440 000	4 050 000	249 000	415 000	630	800	<b>23248CAE4</b>	
	500	155	5	2 600 000	3 800 000	265 000	385 000	670	850	<b>22348CAE4</b>	
	<b>260</b>	360	75	2.1	930 000	1 870 000	95 000	191 000	850	1 000	<b>23952CAE4</b>
		400	104	4	1 430 000	2 580 000	145 000	263 000	800	950	<b>23052CAE4</b>
400		140	4	1 810 000	3 500 000	185 000	360 000	630	850	<b>24052CAE4</b>	
440		144	4	2 160 000	3 750 000	221 000	385 000	600	800	<b>23152CAE4</b>	
440		180	4	2 560 000	4 700 000	261 000	480 000	600	800	<b>24152CAE4</b>	
480		130	5	2 180 000	3 400 000	222 000	345 000	670	850	<b>22252CAE4</b>	
480		174	5	2 740 000	4 550 000	279 000	460 000	560	750	<b>23252CAE4</b>	
540		165	6	3 100 000	4 600 000	320 000	470 000	630	800	<b>22352CAE4</b>	

Note (1) The suffix K or K30 represents bearings with tapered bores (taper 1 : 12 or 1 : 30).

Numbers	Abutment and Fillet Dimensions (mm)					Constant	Axial Load Factors			Mass (kg)			
	Tapered Bore(1)	$d_a$	$D_a$	$r_a$	$e$		$Y_2$	$Y_3$	$Y_0$		approx		
		min	max	max	min	max							
<b>23940CAKE4</b>	Tapered Bore(1)	212	—	268	258	2	0.20	5.1	3.4	3.3	11		
		212	—	298	279	2	0.25	4.0	2.7	2.6	22.6		
		212	223	298	271	2	0.32	3.1	2.1	2.0	30.4		
		214	232	326	293	2.5	0.31	3.2	2.2	2.1	42.7		
		214	226	326	290	2.5	0.39	2.6	1.8	1.7	51.3		
		218	—	342	315	3	0.26	3.8	2.6	2.5	42.6		
		218	237	342	307	3	0.34	2.9	2.0	1.9	57.1		
		222	—	398	352	4	0.34	2.9	2.0	1.9	92.6		
		<b>23944CAKE4</b>	Tapered Bore(1)	232	—	288	278	2	0.18	5.7	3.8	3.7	12.2
				234	—	326	302	2.5	0.24	4.1	2.8	2.7	29.7
234	244			326	296	2.5	0.31	3.2	2.1	2.1	40.5		
238	254			352	320	3	0.30	3.3	2.2	2.2	53		
238	248			352	313	3	0.39	2.6	1.7	1.7	66.7		
238	—			382	348	3	0.27	3.7	2.5	2.4	59		
238	260			382	337	3	0.35	2.9	1.9	1.9	80.4		
242	—			438	391	4	0.33	3.0	2.0	2.0	116		
<b>23948CAKE4</b>	Tapered Bore(1)			252	—	308	298	2	0.17	6.0	4.0	3.9	13.3
				254	—	346	324	2.5	0.24	4.2	2.8	2.7	32.6
		254	265	346	317	2.5	0.29	3.4	2.3	2.2	43.4		
		258	275	382	347	3	0.30	3.3	2.2	2.2	66.9		
		258	268	382	341	3	0.38	2.7	1.8	1.8	79.5		
		258	—	422	383	3	0.27	3.7	2.5	2.4	80.2		
		258	—	422	372	3	0.37	2.7	1.8	1.8	106		
		262	—	478	423	4	0.32	3.2	2.1	2.1	147		
		<b>23952CAKE4</b>	Tapered Bore(1)	272	—	348	333	2	0.19	5.4	3.6	3.5	23
				278	—	382	356	3	0.25	4.1	2.7	2.7	46.6
278	—			382	348	3	0.32	3.1	2.1	2.1	62.6		
278	—			422	380	3	0.32	3.2	2.1	2.1	88.2		
278	—			422	371	3	0.39	2.6	1.7	1.7	109		
282	—			458	418	4	0.27	3.7	2.5	2.5	104		
282	—			458	406	4	0.37	2.7	1.8	1.8	137		
288	—			512	462	5	0.32	3.2	2.1	2.1	180		

Remarks For the dimensions of adapters and withdrawal sleeves, refer to Pages B359 and B365.

Bore Diameter 280~340 mm

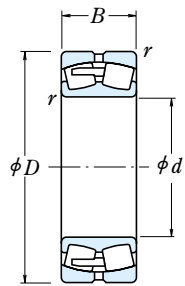

Cylindrical Bore

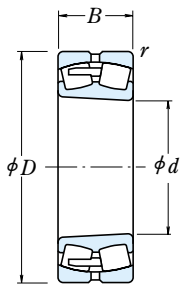

Tapered Bore



Without an Oil Groove and Holes

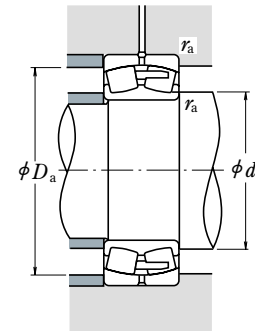

**Dynamic Equivalent Load**

$$P = XF_r + YF_a$$

$F_a/F_r \leq e$		$F_a/F_r > e$	
X	Y	X	Y
1	$Y_3$	0.67	$Y_2$

**Static Equivalent Load**

$$P_0 = F_r + Y_0 F_a$$

The values of  $e$ ,  $Y_2$ ,  $Y_3$ , and  $Y_0$  are given in the table below.

Boundary Dimensions (mm)	Basic Load Ratings				Limiting Speeds (rpm)		Bearing					
	$d$	$D$	$B$	$r_{min}$	(N)	{kgf}		Grease	Oil	Cylindrical Bore		
					$C_r$	$C_{0r}$	$C_r$	$C_{0r}$				
<b>280</b>	380	75	2.1		925 000	1 950 000	94 500	199 000	800	950	<b>23956CAE4</b> <b>23056CAE4</b> <b>24056CAE4</b>	
	420	106	4		1 540 000	2 950 000	157 000	300 000	710	900		
	420	140	4		1 880 000	3 800 000	191 000	385 000	600	800		
	460	146	5		2 230 000	4 000 000	228 000	410 000	560	750	<b>23156CAE4</b> <b>24156CAE4</b> <b>22256CAE4</b>	
	460	180	5		2 640 000	5 000 000	269 000	505 000	560	750		
	500	130	5		2 280 000	3 650 000	233 000	370 000	630	800		
	500	176	5		2 880 000	4 900 000	294 000	500 000	530	670	<b>23256CAE4</b> <b>22356CAE4</b>	
	580	175	6		3 500 000	5 150 000	355 000	525 000	560	710		
	<b>300</b>	420	90	3		1 230 000	2 490 000	125 000	254 000	710	900	<b>23960CAE4</b> <b>23060CAE4</b> <b>24060CAE4</b>
		460	118	4		1 920 000	3 700 000	196 000	375 000	670	850	
		460	160	4		2 310 000	4 600 000	235 000	470 000	530	710	
		500	160	5		2 670 000	4 800 000	273 000	490 000	500	670	<b>23160CAE4</b> <b>24160CAE4</b>
500		200	5		3 100 000	5 800 000	315 000	595 000	500	670		
540		140	5		2 610 000	4 250 000	266 000	430 000	600	750	<b>22260CAE4</b> <b>23260CAE4</b>	
540	192	5		3 400 000	5 900 000	350 000	600 000	480	630			
<b>320</b>	440	90	3		1 300 000	2 750 000	132 000	281 000	670	850	<b>23964CAE4</b> <b>23064CAE4</b> <b>24064CAE4</b>	
	480	121	4		1 960 000	3 850 000	200 000	395 000	630	800		
	480	160	4		2 440 000	5 050 000	249 000	515 000	500	670		
	540	176	5		3 050 000	5 500 000	315 000	560 000	480	600	<b>23164CAE4</b> <b>24164CAE4</b>	
	540	218	5		3 550 000	6 650 000	360 000	675 000	480	600		
	580	150	5		2 990 000	4 850 000	305 000	495 000	530	670	<b>22264CAE4</b> <b>23264CAE4</b>	
580	208	5		3 900 000	6 900 000	395 000	700 000	450	600			
<b>340</b>	460	90	3		1 330 000	2 840 000	136 000	289 000	630	800	<b>23968CAE4</b> <b>23068CAE4</b> <b>24068CAE4</b>	
	520	133	5		2 280 000	4 400 000	232 000	445 000	560	710		
	520	180	5		2 920 000	6 050 000	298 000	615 000	480	600		
	580	190	5		3 600 000	6 600 000	370 000	670 000	430	560	<b>23168CAE4</b> <b>24168CAE4</b>	
	580	243	5		4 250 000	7 900 000	430 000	810 000	430	560		
	620	224	6		4 400 000	7 800 000	450 000	795 000	400	530	<b>23268CAE4</b>	

Note (1) The suffix K or K30 represents bearings with tapered bores (taper 1 : 12 or 1 : 30).

Numbers	Abutment and Fillet Dimensions (mm)				Constant	Axial Load Factors			Mass (kg)
	$d_a$ min	$d_a$ max	$D_a$ min	$r_a$ max		$e$	$Y_2$	$Y_3$	
Tapered Bore(1)									approx
<b>23956CAKE4</b> <b>23056CAKE4</b> <b>24056CAK30E4</b>	292	368	351	2	0.18	5.7	3.9	3.8	24.5
	298	402	377	3	0.24	4.2	2.8	2.7	50.5
	298	402	369	3	0.31	3.3	2.2	2.2	66.4
<b>23156CAKE4</b> <b>24156CAK30E4</b> <b>22256CAKE4</b>	302	438	400	4	0.30	3.3	2.2	2.2	94.3
	302	438	392	4	0.37	2.7	1.8	1.8	115
	302	478	439	4	0.25	4.0	2.7	2.6	110
<b>23256CAKE4</b> <b>22356CAKE4</b>	302	478	425	4	0.35	2.9	1.9	1.9	147
	308	552	496	5	0.31	3.2	2.1	2.1	221
<b>23960CAKE4</b> <b>23060CAKE4</b> <b>24060CAK30E4</b>	314	406	386	2.5	0.19	5.2	3.5	3.4	38.2
	318	442	413	3	0.24	4.2	2.8	2.7	70.5
	318	442	400	3	0.32	3.1	2.1	2.0	93.6
<b>23160CAKE4</b> <b>24160CAK30E4</b>	322	478	433	4	0.31	3.3	2.2	2.2	125
	322	478	423	4	0.38	2.6	1.8	1.7	152
<b>22260CAKE4</b> <b>23260CAKE4</b>	322	518	473	4	0.25	4.0	2.7	2.6	139
	322	518	458	4	0.35	2.9	1.9	1.9	189
<b>23964CAKE4</b> <b>23064CAKE4</b> <b>24064CAK30E4</b>	334	426	406	2.5	0.18	5.5	3.7	3.6	40.6
	338	462	432	3	0.24	4.2	2.8	2.8	75.6
	338	462	422	3	0.31	3.3	2.2	2.2	99.7
<b>23164CAKE4</b> <b>24164CAK30E4</b>	342	518	466	4	0.31	3.2	2.1	2.1	162
	342	518	456	4	0.39	2.6	1.7	1.7	196
<b>22264CAKE4</b> <b>23264CAKE4</b>	342	558	508	4	0.26	3.9	2.6	2.6	174
	342	558	488	4	0.36	2.8	1.9	1.8	239
<b>23968CAKE4</b> <b>23068CAKE4</b> <b>24068CAK30E4</b>	354	446	427	2.5	0.18	5.7	3.8	3.7	42.4
	362	498	465	4	0.24	4.2	2.8	2.8	101
	362	498	454	4	0.32	3.2	2.1	2.1	135
<b>23168CAKE4</b> <b>24168CAK30E4</b> <b>23268CAKE4</b>	362	558	499	4	0.31	3.2	2.1	2.1	206
	362	558	489	4	0.40	2.5	1.7	1.7	257
	368	592	521	5	0.36	2.8	1.9	1.8	295

Remarks For the dimensions of adapters and withdrawal sleeves, refer to Pages B359, B360, B365, and B366.

Bore Diameter 360~440 mm

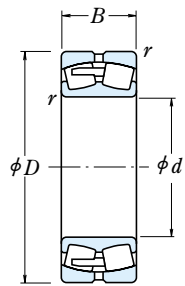

Cylindrical Bore

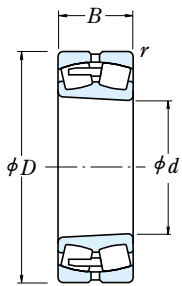

Tapered Bore



Without an Oil Groove and Holes

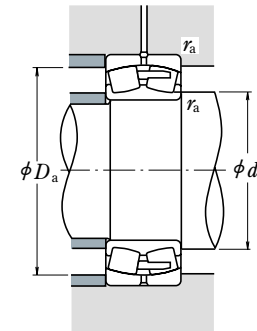

**Dynamic Equivalent Load**

$$P = XF_r + YF_a$$

$F_a/F_r \leq e$		$F_a/F_r > e$	
X	Y	X	Y
1	$Y_3$	0.67	$Y_2$

**Static Equivalent Load**

$$P_0 = F_r + Y_0 F_a$$

The values of  $e$ ,  $Y_2$ ,  $Y_3$ , and  $Y_0$  are given in the table below.

Boundary Dimensions (mm)				Basic Load Ratings				Limiting Speeds (rpm)		Bearing
$d$	$D$	$B$	$r_{min}$	(N)		{kgf}		Grease	Oil	
				$C_r$	$C_{0r}$	$C_r$	$C_{0r}$			
<b>360</b>	480	90	3	1 390 000	3 050 000	142 000	315 000	600	750	<b>23972CAE4</b>
	540	134	5	2 390 000	4 700 000	244 000	480 000	530	670	<b>23072CAE4</b>
	540	180	5	2 930 000	6 100 000	299 000	625 000	450	600	<b>24072CAE4</b>
	600	192	5	3 800 000	7 100 000	390 000	725 000	400	530	<b>23172CAE4</b>
	600	243	5	4 200 000	8 000 000	430 000	815 000	400	530	<b>24172CAE4</b>
	650	232	6	4 800 000	8 550 000	490 000	870 000	380	500	<b>23272CAE4</b>
<b>380</b>	520	106	4	1 870 000	4 100 000	190 000	420 000	530	670	<b>23976CAE4</b>
	560	135	5	2 500 000	5 100 000	255 000	520 000	530	630	<b>23076CAE4</b>
	560	180	5	3 050 000	6 600 000	315 000	670 000	430	560	<b>24076CAE4</b>
	620	194	5	4 000 000	7 600 000	405 000	775 000	400	500	<b>23176CAE4</b>
	620	243	5	4 350 000	8 450 000	440 000	865 000	400	500	<b>24176CAE4</b>
	680	240	6	5 150 000	9 200 000	525 000	940 000	360	480	<b>23276CAE4</b>
<b>400</b>	540	106	4	1 890 000	4 250 000	193 000	435 000	530	630	<b>23980CAE4</b>
	600	148	5	2 970 000	5 900 000	305 000	605 000	480	600	<b>23080CAE4</b>
	600	200	5	3 600 000	7 600 000	370 000	775 000	400	500	<b>24080CAE4</b>
	650	200	6	4 150 000	7 900 000	420 000	805 000	380	480	<b>23180CAE4</b>
	650	250	6	4 950 000	10 100 000	505 000	1 030 000	380	480	<b>24180CAE4</b>
	720	256	6	5 800 000	10 400 000	590 000	1 060 000	340	450	<b>23280CAE4</b>
<b>420</b>	560	106	4	1 870 000	4 250 000	191 000	430 000	500	600	<b>23984CAE4</b>
	620	150	5	2 910 000	5 850 000	297 000	595 000	450	560	<b>23084CAE4</b>
	620	200	5	3 750 000	8 100 000	380 000	825 000	380	480	<b>24084CAE4</b>
	700	224	6	5 000 000	9 400 000	510 000	960 000	340	450	<b>23184CAE4</b>
	700	280	6	6 000 000	12 000 000	610 000	1 220 000	340	450	<b>24184CAE4</b>
	760	272	7.5	6 450 000	11 700 000	660 000	1 190 000	320	430	<b>23284CAE4</b>
<b>440</b>	600	118	4	2 190 000	4 800 000	223 000	490 000	450	560	<b>23988CAE4</b>
	650	157	6	3 150 000	6 350 000	320 000	645 000	430	530	<b>23088CAE4</b>
	650	212	6	4 150 000	9 100 000	425 000	930 000	360	450	<b>24088CAE4</b>
	720	226	6	5 300 000	10 300 000	540 000	1 060 000	320	430	<b>23188CAE4</b>
	720	280	6	6 000 000	12 100 000	610 000	1 230 000	320	430	<b>24188CAE4</b>
	790	280	7.5	6 900 000	12 800 000	705 000	1 300 000	300	400	<b>23288CAE4</b>

Note (1) The suffix K or K30 represents bearings with tapered bores (taper 1 : 12 or 1 : 30).

Numbers	Abutment and Fillet Dimensions (mm)				Constant	Axial Load Factors			Mass (kg)
	$d_a$ min	$d_a$ max	$D_a$ min	$r_a$ max		$e$	$Y_2$	$Y_3$	
Tapered Bore(1)									approx
<b>23972CAKE4</b>	374	466	447	2.5	0.17	6.0	4.1	4.0	44.7
<b>23072CAKE4</b>	382	518	485	4	0.24	4.2	2.8	2.8	106
<b>24072CAK30E4</b>	382	518	476	4	0.32	3.2	2.1	2.1	139
<b>23172CAKE4</b>	382	578	520	4	0.31	3.2	2.2	2.1	217
<b>24172CAK30E4</b>	382	578	507	4	0.40	2.5	1.7	1.7	264
<b>23272CAKE4</b>	388	622	549	5	0.36	2.8	1.9	1.8	342
<b>23976CAKE4</b>	398	502	482	3	0.18	5.5	3.7	3.6	65.4
<b>23076CAKE4</b>	402	538	506	4	0.22	4.5	3.0	3.0	113
<b>24076CAK30E4</b>	402	538	496	4	0.29	3.4	2.3	2.3	148
<b>23176CAKE4</b>	402	598	540	4	0.30	3.3	2.2	2.2	229
<b>24176CAK30E4</b>	402	598	529	4	0.38	2.6	1.8	1.7	275
<b>23276CAKE4</b>	408	652	578	5	0.35	2.9	1.9	1.9	372
<b>23980CAKE4</b>	418	522	501	3	0.18	5.7	3.9	3.8	69.1
<b>23080CAKE4</b>	422	578	540	4	0.23	4.4	3.0	2.9	146
<b>24080CAK30E4</b>	422	578	527	4	0.31	3.3	2.2	2.2	193
<b>23180CAKE4</b>	428	622	569	5	0.29	3.4	2.3	2.3	257
<b>24180CAK30E4</b>	428	622	551	5	0.37	2.7	1.8	1.8	316
<b>23280CAKE4</b>	428	692	610	5	0.36	2.8	1.9	1.9	449
<b>23984CAKE4</b>	438	542	521	3	0.17	6.0	4.0	3.9	71.6
<b>23084CAKE4</b>	442	598	562	4	0.23	4.3	2.9	2.8	151
<b>24084CAK30E4</b>	442	598	549	4	0.31	3.2	2.2	2.1	199
<b>23184CAKE4</b>	448	672	607	5	0.31	3.3	2.2	2.2	341
<b>24184CAK30E4</b>	448	672	598	5	0.38	2.6	1.8	1.7	421
<b>23284CAKE4</b>	456	724	644	6	0.35	2.9	1.9	1.9	534
<b>23988CAKE4</b>	468	582	555	3	0.18	5.7	3.9	3.8	96.3
<b>23088CAKE4</b>	468	622	587	5	0.23	4.3	2.9	2.8	173
<b>24088CAK30E4</b>	468	622	576	5	0.31	3.2	2.1	2.1	237
<b>23188CAKE4</b>	468	692	627	5	0.3	3.3	2.2	2.2	360
<b>24188CAK30E4</b>	468	692	617	5	0.37	2.7	1.8	1.8	433
<b>23288CAKE4</b>	476	754	669	6	0.35	2.9	1.9	1.9	594

Remarks For the dimensions of adapters and withdrawal sleeves, refer to Pages B360, and B366, B367.

Bore Diameter 460~560 mm

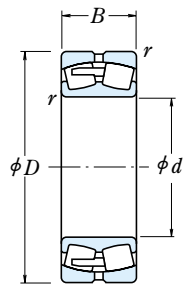

Cylindrical Bore

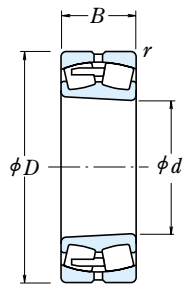

Tapered Bore

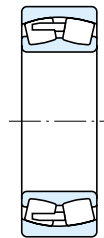

Without an Oil Groove and Holes

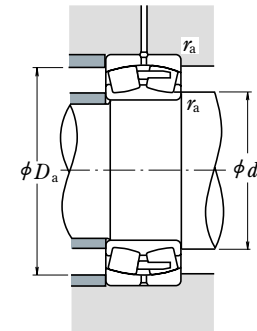

**Dynamic Equivalent Load**

$$P = XF_r + YF_a$$

$F_a/F_r \leq e$		$F_a/F_r > e$	
X	Y	X	Y
1	$Y_3$	0.67	$Y_2$

**Static Equivalent Load**

$$P_0 = F_r + Y_0 F_a$$

The values of  $e$ ,  $Y_2$ ,  $Y_3$ , and  $Y_0$  are given in the table below.

Boundary Dimensions (mm)				Basic Load Ratings (N) {kgf}				Limiting Speeds (rpm)		Bearing
$d$	$D$	$B$	$r_{min}$	$C_r$	$C_{0r}$	$C_r$	$C_{0r}$	Grease	Oil	Cylindrical Bore
<b>460</b>	620	118	4	2 220 000	4 950 000	227 000	505 000	430	530	<b>23992CAE4</b>
	680	163	6	3 450 000	7 100 000	355 000	725 000	400	500	<b>23092CAE4</b>
	680	218	6	4 500 000	9 950 000	460 000	1 010 000	340	430	<b>24092CAE4</b>
	760	240	7.5	5 700 000	10 900 000	580 000	1 110 000	300	400	<b>23192CAE4</b>
	760	300	7.5	6 300 000	12 400 000	640 000	1 270 000	300	400	<b>24192CAE4</b>
	830	296	7.5	7 350 000	13 700 000	750 000	1 400 000	280	380	<b>23292CAE4</b>
<b>480</b>	650	128	5	2 580 000	5 850 000	263 000	595 000	400	500	<b>23996CAE4</b>
	700	165	6	3 800 000	7 950 000	385 000	810 000	400	480	<b>23096CAE4</b>
	700	218	6	4 600 000	10 200 000	470 000	1 040 000	320	430	<b>24096CAE4</b>
	790	248	7.5	6 050 000	11 700 000	620 000	1 200 000	300	380	<b>23196CAE4</b>
	790	308	7.5	7 150 000	14 600 000	730 000	1 490 000	300	380	<b>24196CAE4</b>
	870	310	7.5	7 850 000	14 400 000	805 000	1 470 000	260	360	<b>23296CAE4</b>
<b>500</b>	670	128	5	2 460 000	5 550 000	250 000	565 000	400	500	<b>239/500CAE4</b>
	720	167	6	3 750 000	8 100 000	385 000	825 000	380	480	<b>230/500CAE4</b>
	720	218	6	4 450 000	9 900 000	450 000	1 010 000	300	400	<b>240/500CAE4</b>
	830	264	7.5	6 850 000	13 400 000	700 000	1 360 000	280	360	<b>231/500CAE4</b>
	830	325	7.5	8 000 000	16 000 000	815 000	1 630 000	280	360	<b>241/500CAE4</b>
	920	336	7.5	9 000 000	16 600 000	915 000	1 690 000	260	320	<b>232/500CAE4</b>
<b>530</b>	710	136	5	2 930 000	6 800 000	299 000	695 000	360	450	<b>239/530CAE4</b>
	780	185	6	4 400 000	9 200 000	450 000	940 000	340	430	<b>230/530CAE4</b>
	780	250	6	5 400 000	11 800 000	550 000	1 210 000	280	360	<b>240/530CAE4</b>
	870	272	7.5	7 150 000	14 100 000	730 000	1 440 000	260	340	<b>231/530CAE4</b>
	870	335	7.5	8 500 000	17 500 000	870 000	1 790 000	260	340	<b>241/530CAE4</b>
	980	355	9.5	10 100 000	18 800 000	1 030 000	1 920 000	240	300	<b>232/530CAE4</b>
<b>560</b>	750	140	5	3 100 000	7 250 000	320 000	740 000	340	430	<b>239/560CAE4</b>
	820	195	6	5 000 000	10 700 000	510 000	1 090 000	320	400	<b>230/560CAE4</b>
	820	258	6	5 950 000	13 300 000	605 000	1 360 000	260	340	<b>240/560CAE4</b>
	920	280	7.5	7 850 000	15 500 000	800 000	1 580 000	240	320	<b>231/560CAE4</b>
	920	355	7.5	9 400 000	19 600 000	960 000	2 000 000	240	320	<b>241/560CAE4</b>
	1 030	365	9.5	10 900 000	20 500 000	1 110 000	2 090 000	220	280	<b>232/560CAE4</b>

Note (1) The suffix K or K30 represents bearings with tapered bores (taper 1 : 12 or 1 : 30).

Numbers	Abutment and Fillet Dimensions (mm)				Constant	Axial Load Factors			Mass (kg)
	$d_a$ min	$d_a$ max	$D_a$ min	$r_a$ max		$e$	$Y_2$	$Y_3$	
Tapered Bore(1)									approx
<b>23992CAKE4</b>	478	602	575	3	0.17	5.9	4.0	3.9	100
<b>23092CAKE4</b>	488	652	615	5	0.22	4.6	3.1	3.0	201
<b>24092CAK30E4</b>	488	652	604	5	0.29	3.4	2.3	2.3	266
<b>23192CAKE4</b>	496	724	661	6	0.31	3.3	2.2	2.2	423
<b>24192CAK30E4</b>	496	724	646	6	0.39	2.6	1.7	1.7	512
<b>23292CAKE4</b>	496	794	702	6	0.36	2.8	1.9	1.8	691
<b>23996CAKE4</b>	502	628	602	4	0.18	5.7	3.8	3.7	121
<b>23096CAKE4</b>	508	672	633	5	0.22	4.6	3.1	3.0	211
<b>24096CAK30E4</b>	508	672	625	5	0.30	3.4	2.3	2.2	270
<b>23196CAKE4</b>	516	754	688	6	0.31	3.3	2.2	2.2	475
<b>24196CAK30E4</b>	516	754	670	6	0.39	2.6	1.7	1.7	567
<b>23296CAKE4</b>	516	834	733	6	0.36	2.8	1.9	1.8	795
<b>239/500CAKE4</b>	522	648	622	4	0.17	6.0	4.0	3.9	124
<b>230/500CAKE4</b>	528	692	655	5	0.21	4.8	3.2	3.1	220
<b>240/500CAK30E4</b>	528	692	643	5	0.30	3.4	2.3	2.2	276
<b>231/500CAKE4</b>	536	794	720	6	0.31	3.2	2.2	2.1	567
<b>241/500CAK30E4</b>	536	794	703	6	0.39	2.6	1.7	1.7	666
<b>232/500CAKE4</b>	536	884	773	6	0.38	2.7	1.8	1.8	969
<b>239/530CAKE4</b>	552	688	659	4	0.17	6.0	4.0	3.9	149
<b>230/530CAKE4</b>	558	752	706	5	0.22	4.6	3.1	3.0	298
<b>240/530CAK30E4</b>	558	752	690	5	0.31	3.3	2.2	2.2	390
<b>231/530CAKE4</b>	566	834	758	6	0.30	3.3	2.2	2.2	628
<b>241/530CAK30E4</b>	566	834	740	6	0.38	2.6	1.8	1.7	773
<b>232/530CAKE4</b>	574	936	824	8	0.38	2.7	1.8	1.7	1 170
<b>239/560CAKE4</b>	582	728	697	4	0.16	6.1	4.1	4.0	172
<b>230/560CAKE4</b>	588	792	742	5	0.22	4.5	3.0	2.9	344
<b>240/560CAK30E4</b>	588	792	729	5	0.30	3.3	2.2	2.2	440
<b>231/560CAKE4</b>	596	884	804	6	0.30	3.4	2.3	2.2	727
<b>241/560CAK30E4</b>	596	884	782	6	0.39	2.6	1.8	1.7	886
<b>232/560CAKE4</b>	604	986	870	8	0.36	2.8	1.9	1.8	1 320

Remarks For the dimensions of adapters and withdrawal sleeves, refer to Pages B361 and B367.

Bore Diameter 600~800 mm

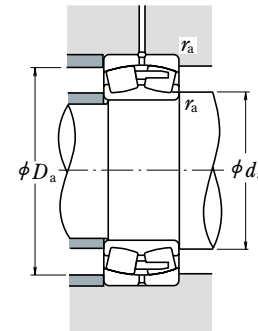
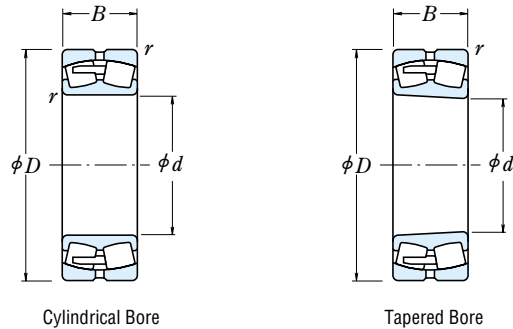

**Dynamic Equivalent Load**

$$P = XF_r + YF_a$$

$F_a/F_r \leq e$		$F_a/F_r > e$	
X	Y	X	Y
1	$Y_3$	0.67	$Y_2$

**Static Equivalent Load**

$$P_0 = F_r + Y_0 F_a$$

The values of  $e$ ,  $Y_2$ ,  $Y_3$ , and  $Y_0$  are given in the table below.

Boundary Dimensions (mm)				Basic Load Ratings (N)				Limiting Speeds (rpm)		Bearing
$d$	$D$	$B$	$r_{min}$	$C_r$	$C_{0r}$	$C_r$ (kgf)		Grease	Oil	Cylindrical Bore
<b>600</b>	800	150	5	3 450 000	8 100 000	350 000	830 000	320	400	<b>239/600CAE4</b>
	870	200	6	5 450 000	12 200 000	555 000	1 240 000	300	360	<b>230/600CAE4</b>
	870	272	6	6 600 000	15 100 000	675 000	1 540 000	240	320	<b>240/600CAE4</b>
	980	300	7.5	8 750 000	17 500 000	895 000	1 790 000	220	280	<b>231/600CAE4</b>
	980	375	7.5	10 400 000	21 900 000	1 060 000	2 230 000	220	280	<b>241/600CAE4</b>
	1 090	388	9.5	12 700 000	24 900 000	1 300 000	2 540 000	200	260	<b>232/600CAE4</b>
<b>630</b>	850	165	6	4 000 000	9 350 000	405 000	950 000	300	360	<b>239/630CAE4</b>
	920	212	7.5	5 900 000	12 700 000	600 000	1 300 000	280	340	<b>230/630CAE4</b>
	920	290	7.5	7 550 000	17 700 000	770 000	1 810 000	220	300	<b>240/630CAE4</b>
	1 030	315	7.5	9 600 000	19 400 000	980 000	1 970 000	200	260	231/630CAE4
	1 030	400	7.5	11 300 000	23 900 000	1 160 000	2 440 000	200	260	<b>241/630CAE4</b>
	1 150	412	12	13 400 000	25 600 000	1 370 000	2 610 000	180	240	<b>232/630CAE4</b>
<b>670</b>	900	170	6	4 350 000	10 300 000	445 000	1 050 000	260	340	<b>239/670CAE4</b>
	980	230	7.5	6 850 000	15 000 000	700 000	1 530 000	240	320	<b>230/670CAE4</b>
	980	308	7.5	8 450 000	19 500 000	860 000	1 990 000	200	260	<b>240/670CAE4</b>
	1 090	336	7.5	10 600 000	21 600 000	1 080 000	2 200 000	190	240	231/670CAE4
	1 090	412	7.5	12 400 000	26 500 000	1 270 000	2 700 000	190	240	<b>241/670CAE4</b>
	1 220	438	12	14 900 000	28 700 000	1 520 000	2 920 000	170	220	<b>232/670CAE4</b>
<b>710</b>	950	180	6	4 800 000	11 700 000	490 000	1 200 000	240	300	<b>239/710CAE4</b>
	1 030	236	7.5	7 100 000	15 800 000	725 000	1 610 000	240	280	<b>230/710CAE4</b>
	1 030	315	7.5	8 850 000	20 700 000	905 000	2 110 000	190	240	<b>240/710CAE4</b>
	1 150	438	9.5	13 900 000	30 500 000	1 410 000	3 100 000	170	220	<b>241/710CAE4</b>
	1 280	450	12	15 700 000	30 500 000	1 600 000	3 100 000	160	200	<b>232/710CAE4</b>
	<b>750</b>	1 000	185	6	5 250 000	12 800 000	535 000	1 310 000	220	280
1 090		250	7.5	7 750 000	17 200 000	790 000	1 750 000	220	260	<b>230/750CAE4</b>
1 090		335	7.5	10 100 000	24 000 000	1 030 000	2 450 000	180	220	<b>240/750CAE4</b>
1 360		475	15	17 700 000	35 500 000	1 800 000	3 600 000	140	190	<b>232/750CAE4</b>
<b>800</b>	1 060	195	6	5 600 000	13 700 000	570 000	1 400 000	220	260	<b>239/800CAE4</b>
	1 150	258	7.5	8 350 000	19 100 000	850 000	1 950 000	200	240	<b>230/800CAE4</b>
	1 150	345	7.5	10 900 000	26 300 000	1 110 000	2 680 000	160	200	<b>240/800CAE4</b>
	1 280	375	9.5	13 800 000	29 200 000	1 410 000	2 970 000	150	190	231/800CAE4
	1 420	488	15	20 300 000	41 000 000	2 070 000	4 150 000	130	170	<b>232/800CAE4</b>

Note (1) The suffix K or K30 represents bearings with tapered bores (taper 1 : 12 or 1 : 30).

Numbers	Abutment and Fillet Dimensions (mm)				Constant	Axial Load Factors			Mass (kg)
	$d_a$ min	$d_a$ max	$D_a$ min	$r_a$ max		$e$	$Y_2$	$Y_3$	
Tapered Bore(1)									approx
<b>239/600CAKE4</b>	622	778	745	4	0.17	5.9	3.9	3.9	205
<b>230/600CAKE4</b>	628	842	794	5	0.21	4.8	3.3	3.2	389
<b>240/600CAK30E4</b>	628	842	772	5	0.30	3.3	2.2	2.2	529
<b>231/600CAKE4</b>	636	944	856	6	0.30	3.4	2.3	2.2	898
<b>241/600CAK30E4</b>	636	944	836	6	0.39	2.6	1.8	1.7	1 050
<b>232/600CAKE4</b>	644	1 046	923	8	0.36	2.8	1.9	1.8	1 590
<b>239/630CAKE4</b>	658	822	786	5	0.18	5.6	3.8	3.7	259
<b>230/630CAKE4</b>	666	884	835	6	0.22	4.7	3.1	3.1	468
<b>240/630CAK30E4</b>	666	884	815	6	0.30	3.3	2.2	2.2	637
231/630CAKE4	666	994	900	6	0.30	3.4	2.3	2.2	1 040
<b>241/630CAK30E4</b>	666	994	876	6	0.38	2.7	1.8	1.7	1 250
<b>232/630CAKE4</b>	684	1 096	970	10	0.36	2.8	1.9	1.8	1 850
<b>239/670CAKE4</b>	698	872	836	5	0.17	5.8	3.9	3.8	300
<b>230/670CAKE4</b>	706	944	891	6	0.22	4.7	3.1	3.1	571
<b>240/670CAK30E4</b>	706	944	868	6	0.30	3.3	2.2	2.2	773
231/670CAKE4	706	1 054	952	6	0.30	3.3	2.2	2.2	1 230
<b>241/670CAK30E4</b>	706	1 054	934	6	0.37	2.7	1.8	1.8	1 440
<b>232/670CAKE4</b>	724	1 166	1 024	10	0.37	2.7	1.8	1.8	2 210
<b>239/710CAKE4</b>	738	922	883	5	0.17	5.8	3.9	3.8	352
<b>230/710CAKE4</b>	746	994	936	6	0.22	4.6	3.1	3.0	647
<b>240/710CAK30E4</b>	746	994	916	6	0.29	3.4	2.3	2.2	861
<b>241/710CAK30E4</b>	754	1 106	981	8	0.38	2.6	1.8	1.7	1 730
<b>232/710CAKE4</b>	764	1 226	1 080	10	0.36	2.8	1.9	1.8	2 470
<b>239/750CAKE4</b>	778	972	931	5	0.17	6.0	4.1	4.0	398
<b>230/750CAKE4</b>	786	1 054	990	6	0.22	4.6	3.1	3.0	768
<b>240/750CAK30E4</b>	786	1 054	969	6	0.29	3.4	2.3	2.2	1 030
<b>232/750CAKE4</b>	814	1 296	1 148	12	0.36	2.8	1.9	1.8	2 980
<b>239/800CAKE4</b>	828	1 032	987	5	0.17	6.0	4.0	3.9	462
<b>230/800CAKE4</b>	836	1 114	1 045	6	0.21	4.7	3.2	3.1	870
<b>240/800CAK30E4</b>	836	1 114	1 029	6	0.27	3.7	2.5	2.5	1 130
231/800CAKE4	844	1 236	1 127	8	0.28	3.6	2.4	2.3	1870
<b>232/800CAKE4</b>	864	1 356	1 208	12	0.35	2.8	1.9	1.9	3 250

Bore Diameter 850~1400 mm

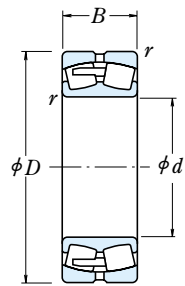

Cylindrical Bore

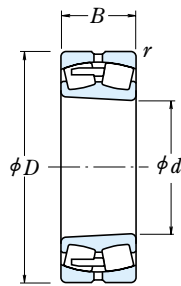

Tapered Bore

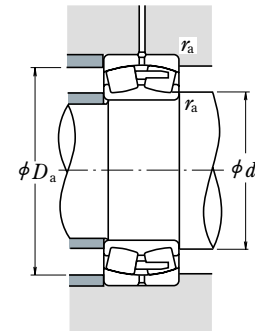

**Dynamic Equivalent Load**

$$P = XF_r + YF_a$$

$F_a/F_r \leq e$		$F_a/F_r > e$	
X	Y	X	Y
1	$Y_3$	0.67	$Y_2$

**Static Equivalent Load**

$$P_0 = F_r + Y_0 F_a$$

The values of  $e$ ,  $Y_2$ ,  $Y_3$ , and  $Y_0$  are given in the table below.

Boundary Dimensions (mm)	Basic Load Ratings				Limiting Speeds (rpm)		Bearing			
	$d$	$D$	$B$	$r_{min}$	$C_r$ (N)	$C_{0r}$ (kgf)		Grease	Oil	Cylindrical Bore
850	1 120	200	6	6 100 000	15 200 000	620 000	1 550 000	190	240	<b>239/850CAE4</b>
	1 220	272	7.5	9 300 000	21 400 000	945 000	2 190 000	180	220	<b>230/850CAE4</b>
	1 220	365	7.5	11 600 000	28 300 000	1 180 000	2 890 000	150	190	<b>240/850CAE4</b>
	1 500	515	15	22 300 000	45 500 000	2 270 000	4 650 000	120	160	<b>232/850CAE4</b>
900	1 180	206	6	6 600 000	16 700 000	670 000	1 700 000	180	220	<b>239/900CAE4</b>
	1 280	280	7.5	9 850 000	22 800 000	1 000 000	2 330 000	160	200	230/900CAE4
	1 280	375	7.5	12 800 000	31 500 000	1 300 000	3 250 000	140	180	<b>240/900CAE4</b>
	1 580	515	15	23 400 000	47 500 000	2 380 000	4 850 000	110	140	<b>232/900CAE4</b>
950	1 250	224	7.5	7 600 000	19 900 000	775 000	2 030 000	160	200	<b>239/950CAE4</b>
	1 360	300	7.5	11 300 000	26 500 000	1 160 000	2 710 000	150	190	<b>230/950CAE4</b>
	1 360	412	7.5	14 500 000	36 500 000	1 480 000	3 700 000	120	160	<b>240/950CAE4</b>
	1 660	530	15	24 700 000	50 500 000	2 520 000	5 150 000	100	130	<b>232/950CAE4</b>
1 000	1 320	236	7.5	8 200 000	21 700 000	835 000	2 210 000	150	190	239/1000CAE4
	1 420	308	7.5	11 900 000	28 100 000	1 210 000	2 860 000	140	170	230/1000CAE4
	1 420	412	7.5	15 300 000	38 500 000	1 560 000	3 950 000	110	150	<b>240/1000CAE4</b>
1 060	1 400	250	7.5	9 300 000	24 400 000	950 000	2 490 000	130	170	<b>239/1060CAE4</b>
	1 500	325	9.5	13 000 000	31 500 000	1 330 000	3 200 000	120	160	<b>230/1060CAE4</b>
	1 500	438	9.5	16 800 000	43 000 000	1 720 000	4 350 000	100	130	240/1060CAE4
1 120	1 580	345	9.5	15 400 000	38 000 000	1 570 000	3 850 000	110	140	230/1120CAE4
	1 580	462	9.5	18 700 000	49 500 000	1 910 000	5 050 000	95	120	<b>240/1120CAE4</b>
1 180	1 660	475	9.5	20 200 000	52 500 000	2 060 000	5 350 000	85	110	240/1180CAE4
1 250	1 750	500	9.5	21 000 000	59 500 000	2 140 000	6 050 000	75	100	<b>240/1250CAE4</b>
1 320	1 850	530	12	22 600 000	63 500 000	2 310 000	6 500 000	67	85	<b>240/1320CAE4</b>
1 400	1 950	545	12	24 500 000	65 000 000	2 500 000	6 650 000	60	75	<b>240/1400CAE4</b>

Note (1) The suffix K or K30 represents bearings with tapered bores (taper 1 : 12 or 1 : 30).

Numbers	Abutment and Fillet Dimensions (mm)				Constant	Axial Load Factors			Mass (kg)
	$d_a$ min	$d_a$ max	$D_a$ min	$r_a$ max		$e$	$Y_2$	$Y_3$	
Tapered Bore(1)									approx
<b>239/850CAKE4</b> <b>230/850CAKE4</b>	878	1 092	1 046	5	0.16	6.2	4.2	4.1	523
	886	1 184	1 109	6	0.21	4.8	3.2	3.1	1 020
<b>240/850CAK30E4</b> <b>232/850CAKE4</b>	886	1 184	1 093	6	0.28	3.6	2.4	2.4	1 350
	914	1 436	1 274	12	0.35	2.8	1.9	1.9	3 890
<b>239/900CAKE4</b> 230/900CAKE4	928	1 152	1 103	5	0.16	6.4	4.3	4.2	591
	936	1 244	1 169	6	0.20	4.9	3.3	3.2	1 160
<b>240/900CAK30E4</b> <b>232/900CAKE4</b>	936	1 244	1 147	6	0.28	3.6	2.4	2.4	1 520
	964	1 516	1 354	12	0.33	3.0	2.0	2.0	4 300
<b>239/950CAKE4</b> <b>230/950CAKE4</b>	986	1 214	1 169	6	0.16	6.3	4.2	4.1	732
	986	1 324	1 241	6	0.21	4.8	3.2	3.2	1 400
<b>240/950CAK30E4</b> <b>232/950CAKE4</b>	986	1 324	1 219	6	0.28	3.6	2.4	2.3	1 880
	1 014	1 596	1 428	12	0.32	3.1	2.1	2.1	4 800
239/1000CAKE4 230/1000CAKE4	1 036	1 284	1 229	6	0.16	6.4	4.3	4.2	881
	1 036	1 384	1 298	6	0.20	4.9	3.3	3.2	1 560
<b>240/1000CAK30E4</b>	1 036	1 384	1 275	6	0.27	3.7	2.5	2.4	2 010
<b>239/1060CAKE4</b> <b>230/1060CAKE4</b>	1 096	1 364	1 302	6	0.16	6.1	4.1	4.0	1 030
	1 104	1 456	1 368	8	0.21	4.9	3.3	3.2	1 790
240/1060CAK30E4	1 104	1 456	1 346	8	0.28	3.6	2.4	2.4	2 410
230/1120CAKE4 <b>240/1120CAK30E4</b>	1 164	1 536	1 444	8	0.20	5.0	3.4	3.3	2 120
	1 164	1 536	1 421	8	0.27	3.7	2.5	2.5	2 790
240/1180CAK30E4	1 224	1 616	1 494	8	0.27	3.7	2.5	2.4	3 180
<b>240/1250CAK30E4</b>	1 294	1 706	1 579	8	0.25	4.0	2.7	2.6	3 700
<b>240/1320CAK30E4</b>	1 374	1 796	1 656	10	0.26	3.9	2.6	2.6	4 400
<b>240/1400CAK30E4</b>	1 454	1 896	1 767	10	0.25	4.0	2.7	2.6	4 900



## THRUST BEARINGS

### SINGLE-DIRECTION THRUST BALL BEARINGS

With Flat Seat, Aligning Seat, or Aligning Seat Washer    Bore Diameter 10~100mm.....Pages B206~B209  
 Bore Diameter 110~360mm.....Pages B210~B213

### DOUBLE-DIRECTION THRUST BALL BEARINGS

With Flat Seat, Aligning Seat, or Aligning Seat Washer    Bore Diameter 10~190mm.....Pages B214~B219

**CYLINDRICAL ROLLER THRUST BEARINGS**    Bore Diameter 35~320mm.....Pages B220~B223

**SPHERICAL THRUST ROLLER BEARINGS**    Bore Diameter 60~500mm.....Pages B224~B229

**Angular Contact Thrust Ball Bearings** are described on pages B230 to B239.



## DESIGN, TYPES, AND FEATURES

### THRUST BALL BEARINGS

Thrust ball bearings are classified into those with flat seats or aligning seats depending on the shape of the outer ring seat (housing washer). They can sustain axial loads but no radial loads.

The series of thrust ball bearings available are shown in Table 1. For Single-Direction Thrust Ball Bearings, pressed steel cages and machined brass cages are usually used as shown in Table 2. The cages in Double-Direction Thrust Ball Bearings are the same as those in Single-Direction Thrust Ball Bearings of the same diameter series.

The basic load ratings listed in the bearing tables are based on the standard cage type shown in Table 2. If the type of cage is different for bearings with the same number, the number of balls may vary, in such a case, the load rating will differ from the one listed in the bearing tables.

**Table 1 Series of Thrust Ball Bearings**

	W/Flat Seat	W/Aligning Seat	W/Aligning Seat Washer
Single-Direction	511	—	—
	512	532	532U
	513	533	533U
	514	534	534U
Double-Direction	522	542	542U
	523	543	543U
	524	544	544U

**Table 2 Standard Cages for Thrust Ball Bearings**

Pressed Steel	Machined Brass
51100~51152X 51200~51236X 51305~51336X	51156X~51172X 51238X~51272X 51338X~51340X
51405~51418X 53200~53236X 53305~53336X 53405~53418X	51420X~51436X 53238X~53272X 53338X~53340X 53420X~53436X

**CYLINDRICAL ROLLER THRUST BEARINGS**

These are thrust bearings containing cylindrical rollers. They can sustain only axial loads, but they are suitable for heavy loads and have high axial rigidity.

The cages are machined brass.

**SPHERICAL THRUST ROLLER BEARINGS**

These are thrust bearings containing convex rollers. They have a self-aligning capability and are free of any influence of mounting error or shaft deflection. Besides the original type, the E type with pressed cages for high load capacity is also available. Their bearing numbers are suffixed by E.

For horizontal shaft or high speed application, machined brass cages are recommended. For details, contact NSK.

Since there are several places where lubrication is difficult, such as the area between the roller heads and inner ring rib, the sliding surfaces between cage and guide sleeve, etc., oil lubrication should be used even at low speed.

The cages in the original type are machined brass.

**TOLERANCES AND RUNNING ACCURACY**

**THRUST BALL BEARINGS** .....Table 8.6 (Pages A72-A74)

**CYLINDRICAL ROLLER THRUST BEARINGS**  
.....According to Table 8.2 (Pages A72-A74)

**SPHERICAL THRUST ROLLER BEARINGS** .....Table 8.7 (Pages A75)

**RECOMMENDED FITS**

**THRUST BALL BEARINGS** .....Table 9.3 (Pages A84)  
Table 9.5 (Pages A85)

**CYLINDRICAL ROLLER THRUST BEARINGS** .....Table 9.3 (Pages A84)  
Table 9.5 (Pages A85)

**SPHERICAL THRUST ROLLER BEARINGS** .....Table 9.3 (Pages A84)  
Table 9.5 (Pages A85)

**DIMENSIONS RELATED TO MOUNTING**

The dimensions related to mounting of spherical thrust roller bearings are listed in the Bearing Table.

If the bearing load is heavy, it is necessary to design the shaft shoulder with ample strength in order to provide sufficient support for the shaft washer.

**PERMISSIBLE MISALIGNMENT**

The permissible misalignment of Spherical Thrust Roller Bearings varies depending on the size, but it is approximately 0.018 to 0.036 radian (1° to 2°) with average loads.

**MINIMUM AXIAL LOAD**

It is necessary to apply some axial load to thrust bearings to prevent slippage between the rolling elements and raceways. For more details, please refer to Page A99.

# SINGLE-DIRECTION THRUST BALL BEARINGS

Bore Diameter 10~50 mm

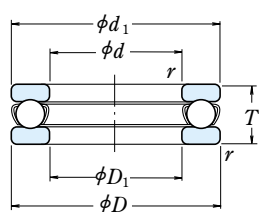

With Flat Seat

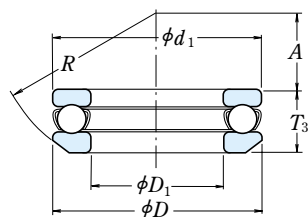

With Aligning Seat

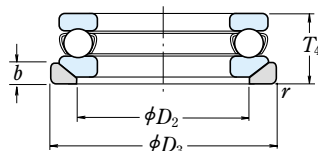

With Aligning Seat Washer

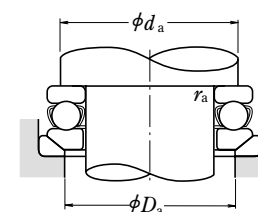
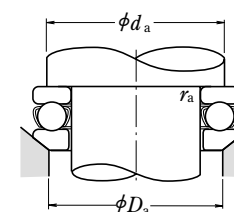
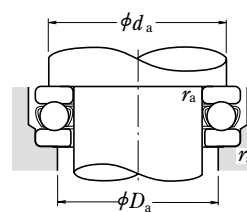

d	Boundary Dimensions (mm)					Basic Load Ratings (N)				Limiting Speeds (rpm)		With Flat Seat
	D	T	T <sub>3</sub>	T <sub>4</sub>	r <sub>min</sub>	C <sub>a</sub>	C <sub>0a</sub>	C <sub>a</sub>	C <sub>0a</sub>	Grease	Oil	
10	24	9	—	—	0.3	10 100	14 000	1 030	1 420	6 700	10 000	51100
	26	11	11.6	13	0.6	12 800	17 100	1 300	1 740	6 000	9 000	51200
12	26	9	—	—	0.3	10 400	15 400	1 060	1 570	6 700	10 000	51101
	28	11	11.4	13	0.6	13 300	19 000	1 350	1 940	5 600	8 500	51201
15	28	9	—	—	0.3	10 600	16 800	1 080	1 710	6 300	9 500	51102
	32	12	13.3	15	0.6	16 700	24 800	1 710	2 530	5 000	7 500	51202
17	30	9	—	—	0.3	11 400	19 500	1 170	1 990	6 000	9 000	51103
	35	12	13.2	15	0.6	17 300	27 300	1 760	2 780	4 800	7 500	51203
20	35	10	—	—	0.3	15 100	26 600	1 540	2 710	5 300	8 000	51104
	40	14	14.7	17	0.6	22 500	37 500	2 290	3 850	4 300	6 300	51204
25	42	11	—	—	0.6	19 700	37 000	2 010	3 800	4 800	7 100	51105
	47	15	16.7	19	0.6	28 000	50 500	2 860	5 150	3 800	5 600	51205
	52	18	19.8	22	1	36 000	61 500	3 650	6 250	3 200	5 000	51305
	60	24	26.4	29	1	56 000	89 500	5 700	9 100	2 600	4 000	51405
30	47	11	—	—	0.6	20 600	42 000	2 100	4 300	4 300	6 700	51106
	52	16	17.8	20	0.6	29 500	58 000	3 000	5 950	3 400	5 300	51206
	60	21	22.6	25	1	43 000	78 500	4 400	8 000	2 800	4 300	51306
	70	28	30.1	33	1	73 000	126 000	7 450	12 800	2 200	3 400	51406
35	52	12	—	—	0.6	22 100	49 500	2 250	5 050	4 000	6 000	51107
	62	18	19.9	22	1	39 500	78 000	4 050	7 950	3 000	4 500	51207
	68	24	25.6	28	1	56 000	105 000	5 700	10 700	2 400	3 800	51307
	80	32	34	37	1.1	87 500	155 000	8 950	15 800	2 000	3 000	51407
40	60	13	—	—	0.6	27 100	63 000	2 770	6 400	3 600	5 300	51108
	68	19	20.3	23	1	47 500	98 500	4 850	10 000	2 800	4 300	51208
	78	26	28.5	31	1	70 000	135 000	7 100	13 700	2 200	3 400	51308
	90	36	38.2	42	1.1	103 000	188 000	10 500	19 100	1 700	2 600	51408
45	65	14	—	—	0.6	28 100	69 000	2 860	7 050	3 400	5 000	51109
	73	20	21.3	24	1	48 000	105 000	4 900	10 700	2 600	4 000	51209
	85	28	30.1	33	1	80 500	163 000	8 200	16 700	2 000	3 000	51309
	100	39	42.4	46	1.1	128 000	246 000	13 000	25 100	1 600	2 400	51409
50	70	14	—	—	0.6	29 000	75 500	2 960	7 700	3 200	4 800	51110
	78	22	23.5	26	1	49 000	111 000	5 000	11 400	2 400	3 600	51210
	95	31	34.3	37	1.1	97 500	202 000	9 950	20 600	1 800	2 800	51310
	110	43	45.6	50	1.5	147 000	288 000	15 000	29 400	1 400	2 200	51410

Bearing Numbers		Dimensions (mm)							Abutment and Fillet Dimensions (mm)			Mass(kg) approx		
With Aligning Seat	With Aligning Seat Washer	d <sub>1</sub>	D <sub>1</sub>	D <sub>2</sub>	D <sub>3</sub>	b	A	R	d <sub>a</sub> min	D <sub>a</sub> max	r <sub>a</sub> max	With Flat Seat	With Aligning Seat	With Aligning Seat Washer
—	—	24	11	—	—	—	—	—	18	16	0.3	0.019	—	—
53200	53200 U	26	12	18	28	3.5	8.5	22	20	16	0.6	0.028	0.029	0.036
—	—	26	13	—	—	—	—	—	20	18	0.3	0.021	—	—
53201	53201 U	28	14	20	30	3.5	11.5	25	22	18	0.6	0.031	0.031	0.039
—	—	28	16	—	—	—	—	—	23	20	0.3	0.023	—	—
53202	53202 U	32	17	24	35	4	12	28	25	22	0.6	0.043	0.048	0.059
—	—	30	18	—	—	—	—	—	25	22	0.3	0.025	—	—
53203	53203 U	35	19	26	38	4	16	32	28	24	0.6	0.050	0.055	0.069
—	—	35	21	—	—	—	—	—	29	26	0.3	0.037	—	—
53204	53204 U	40	22	30	42	5	18	36	32	28	0.6	0.077	0.080	0.096
—	—	42	26	—	—	—	—	—	35	32	0.6	0.056	—	—
53205	53205 U	47	27	36	50	5.5	19	40	38	34	0.6	0.111	0.123	0.151
53305	53305 U	52	27	38	55	6	21	45	41	36	1	0.169	0.182	0.224
53405	53405 U	60	27	42	62	8	19	50	46	39	1	0.334	0.353	0.426
—	—	47	32	—	—	—	—	—	40	37	0.6	0.064	—	—
53206	53206 U	52	32	42	55	5.5	22	45	43	39	0.6	0.137	0.154	0.183
53306	53306 U	60	32	45	62	7	22	50	48	42	1	0.267	0.28	0.336
53406	53406 U	70	32	50	75	9	20	56	54	46	1	0.519	0.535	0.666
—	—	52	37	—	—	—	—	—	45	42	0.6	0.081	—	—
53207	53207 U	62	37	48	65	7	24	50	51	46	1	0.21	0.231	0.292
53307	53307 U	68	37	52	72	7.5	24	56	55	48	1	0.386	0.403	0.488
53407	53407 U	80	37	58	85	10	23	64	62	53	1	0.769	0.785	0.967
—	—	60	42	—	—	—	—	—	52	48	0.6	0.12	—	—
53208	53208 U	68	42	55	72	7	28.5	56	57	51	1	0.27	0.289	0.355
53308	53308 U	78	42	60	82	8.5	28	64	63	55	1	0.536	0.581	0.704
53408	53408 U	90	42	65	95	12	26	72	70	60	1	1.1	1.12	1.38
—	—	65	47	—	—	—	—	—	57	53	0.6	0.143	—	—
53209	53209 U	73	47	60	78	7.5	26	56	62	56	1	0.31	0.333	0.419
53309	53309 U	85	47	65	90	10	25	64	69	61	1	0.672	0.702	0.888
53409	53409 U	100	47	72	105	12.5	29	80	78	67	1	1.46	1.53	1.87
—	—	70	52	—	—	—	—	—	62	58	0.6	0.153	—	—
53210	53210 U	78	52	62	82	7.5	32.5	64	67	61	1	0.378	0.404	0.504
53310	53310 U	95	52	72	100	11	28	72	77	68	1	0.931	1.01	1.27
53410	53410 U	110	52	80	115	14	35	90	86	74	1.5	1.94	1.98	2.41

Bore Diameter 55~100 mm

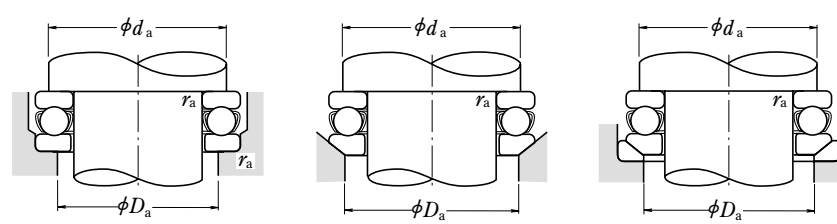
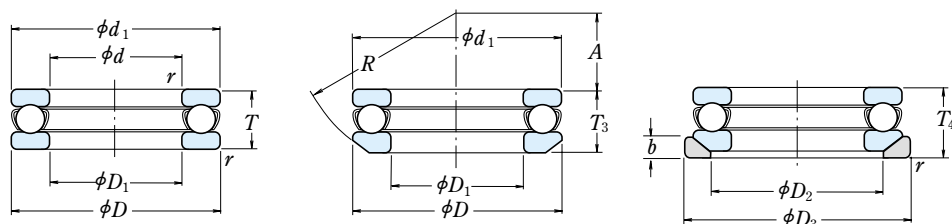

With Flat Seat

With Aligning Seat

With Aligning Seat Washer

d	Boundary Dimensions (mm)					Basic Load Ratings (N)				Limiting Speeds (rpm)		With Flat Seat
	D	T	T <sub>3</sub>	T <sub>4</sub>	r <sub>min</sub>	C <sub>a</sub>	C <sub>0a</sub>	C <sub>a</sub>	C <sub>0a</sub>	Grease	Oil	
55	78	16	—	—	0.6	35 000	93 000	3 600	9 500	2 800	4 300	51111
	90	25	27.3	30	1	70 000	159 000	7 150	16 200	2 200	3 200	51211
	105	35	39.3	42	1.1	115 000	244 000	11 800	24 900	1 600	2 400	51311
	120	48	50.5	55	1.5	181 000	350 000	18 500	35 500	1 300	1 900	51411
60	85	17	—	—	1	41 500	113 000	4 250	11 500	2 600	4 000	51112
	95	26	28	31	1	71 500	169 000	7 300	17 200	2 000	3 000	51212
	110	35	38.3	42	1.1	119 000	263 000	12 100	26 800	1 600	2 400	51312
	130	51	54	58	1.5	202 000	395 000	20 600	40 500	1 200	1 800	51412
65	90	18	—	—	1	42 000	117 000	4 300	12 000	2 400	3 800	51113
	100	27	28.7	32	1	75 500	189 000	7 700	19 200	1 900	2 800	51213
	115	36	39.4	43	1.1	123 000	282 000	12 500	28 700	1 500	2 400	51313
	140	56	60.2	65	2	234 000	495 000	23 800	50 500	1 100	1 700	51413
70	95	18	—	—	1	43 500	127 000	4 450	12 900	2 400	3 600	51114
	105	27	28.8	32	1	74 000	189 000	7 550	19 200	1 900	2 800	51214
	125	40	44.2	48	1.1	137 000	315 000	14 000	32 000	1 400	2 000	51314
	150	60	63.6	69	2	252 000	555 000	25 700	56 500	1 000	1 500	51414
75	100	19	—	—	1	43 500	131 000	4 450	13 400	2 200	3 400	51115
	110	27	28.3	32	1	78 000	209 000	7 950	21 300	1 800	2 800	51215
	135	44	48.1	52	1.5	159 000	365 000	16 200	37 500	1 300	1 900	51315
	160	65	69	75	2	254 000	560 000	25 900	57 000	950	1 400	51415
80	105	19	—	—	1	45 000	141 000	4 600	14 400	2 200	3 400	51116
	115	28	29.5	33	1	79 000	218 000	8 050	22 300	1 800	2 600	51216
	140	44	47.6	52	1.5	164 000	395 000	16 700	40 000	1 300	1 900	51316
	170	68	72.2	78	2.1	272 000	620 000	27 800	63 500	900	1 300	51416
85	110	19	—	—	1	46 500	150 000	4 700	15 300	2 200	3 200	51117
	125	31	33.1	37	1	96 000	264 000	9 800	26 900	1 600	2 400	51217
	150	49	53.1	58	1.5	207 000	490 000	21 100	50 000	1 100	1 700	51317
	180	72	77	83	2.1	310 000	755 000	31 500	77 000	850	1 300	51417 X
90	120	22	—	—	1	60 000	190 000	6 150	19 400	1 900	3 000	51118
	135	35	38.5	42	1.1	114 000	310 000	11 600	31 500	1 400	2 200	51218
	155	50	54.6	59	1.5	214 000	525 000	21 900	53 500	1 100	1 700	51318
	190	77	81.2	88	2.1	330 000	825 000	33 500	84 000	800	1 200	51418 X
100	135	25	—	—	1	86 000	268 000	8 750	27 300	1 700	2 600	51120
	150	38	40.9	45	1.1	135 000	375 000	13 700	38 500	1 300	2 000	51220
	170	55	59.2	64	1.5	239 000	595 000	24 300	61 000	1 000	1 500	51320
	210	85	90	98	3	370 000	985 000	38 000	100 000	710	1 100	51420 X

Note (1) The outside diameter  $d_1$  of the shaft washers of all bearing numbers marked X is smaller than the outside diameter  $D$  of the housing washers.

Bearing Numbers <sup>(1)</sup>		Dimensions (mm)							Abutment and Fillet Dimensions (mm)			Mass(kg) approx		
With Aligning Seat	With Aligning Seat Washer	$d_1$	$D_1$	$D_2$	$D_3$	b	A	R	$d_a$ min	$D_a$ max	$r_a$ max	With Flat Seat	With Aligning Seat	With Aligning Seat Washer
—	—	78	57	—	—	—	—	—	69	64	0.6	0.227	—	—
53211	53211 U	90	57	72	95	9	35	72	76	69	1	0.599	0.656	0.819
53311	53311 U	105	57	80	110	11.5	30	80	85	75	1	1.31	1.45	1.78
53411	53411 U	120	57	88	125	15.5	28	90	94	81	1.5	2.58	2.59	3.16
—	—	85	62	—	—	—	—	—	75	70	1	0.281	—	—
53212	53212 U	95	62	78	100	9	32.5	72	81	74	1	0.673	0.731	0.897
53312	53312 U	110	62	85	115	11.5	41	90	90	80	1	1.4	1.51	1.83
53412	53412 U	130	62	95	135	16	34	100	102	88	1.5	3.16	3.2	3.91
—	—	90	67	—	—	—	—	—	80	75	1	0.324	—	—
53213	53213 U	100	67	82	105	9	40	80	86	79	1	0.756	0.812	0.989
53313	53313 U	115	67	90	120	12.5	38.5	90	95	85	1	1.54	1.67	2.04
53413	53413 U	140	68	100	145	17.5	40	112	110	95	2	4.1	4.22	5.13
—	—	95	72	—	—	—	—	—	85	80	1	0.346	—	—
53214	53214 U	105	72	88	110	9	38	80	91	84	1	0.793	0.866	1.05
53314	53314 U	125	72	98	130	13	43	100	103	92	1	2.0	2.2	2.64
53414	53414 U	150	73	110	155	19.5	34	112	118	102	2	5.05	5.12	6.21
—	—	100	77	—	—	—	—	—	90	85	1	0.389	—	—
53215	53215 U	110	77	92	115	9.5	49	90	96	89	1	0.845	1.27	1.11
53315	53315 U	135	77	105	140	15	37	100	111	99	1.5	2.6	2.8	3.42
53415	53415 U	160	78	115	165	21	42	125	125	110	2	6.15	6.23	7.58
—	—	105	82	—	—	—	—	—	95	90	1	0.417	—	—
53216	53216 U	115	82	98	120	10	46	90	101	94	1	0.931	1.01	1.23
53316	53316 U	140	82	110	145	15	50	112	116	104	1.5	2.74	2.94	3.55
53416	53416 U	170	83	125	175	22	36	125	133	117	2	7.21	7.33	8.9
—	—	110	87	—	—	—	—	—	100	95	1	0.44	—	—
53217	53217 U	125	88	105	130	11	52	100	109	101	1	1.22	1.35	1.63
53317	53317 U	150	88	115	155	17.5	43	112	124	111	1.5	3.57	3.78	4.67
53417 X	53417 XU	177	88	130	185	23	47	140	141	124	2	8.51	8.72	10.4
—	—	120	92	—	—	—	—	—	108	102	1	0.646	—	—
53218	53218 U	135	93	110	140	13.5	45	100	117	108	1	1.69	1.89	2.38
53318	53318 U	155	93	120	160	18	40	112	129	116	1.5	3.83	4.11	5.09
53418 X	53418 XU	187	93	140	195	25.5	40	140	149	131	2	10.2	10.3	12.4
—	—	135	102	—	—	—	—	—	121	114	1	0.96	—	—
53220	53220 U	150	103	125	155	14	52	112	130	120	1	2.25	2.49	3.03
53320	53320 U	170	103	135	175	18	46	125	142	128	1.5	4.98	5.31	6.37
53420 X	53420 XU	205	103	155	220	27	50	160	165	145	2.5	14.8	15	18.1

Bore Diameter 110~190 mm

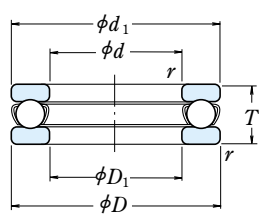

With Flat Seat

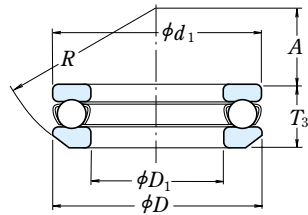

With Aligning Seat

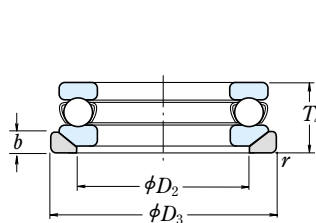

With Aligning Seat Washer

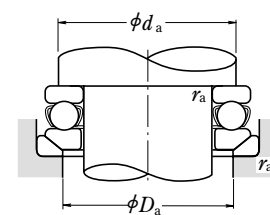
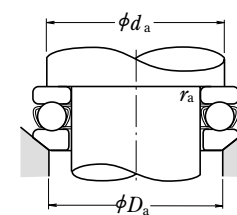
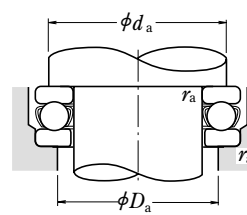

d	Boundary Dimensions (mm)					Basic Load Ratings (N)				Limiting Speeds (rpm)		With Flat Seat
	D	T	T <sub>3</sub>	T <sub>4</sub>	r <sub>min</sub>	C <sub>a</sub>	C <sub>0a</sub>	C <sub>a</sub>	C <sub>0a</sub>	Grease	Oil	
110	145	25	—	—	1	88 000	288 000	8 950	29 400	1 700	2 400	51122
	160	38	40.2	45	1.1	136 000	395 000	13 900	40 000	1 300	1 900	51222
	190	63	67.2	72	2	282 000	755 000	28 800	77 000	900	1 300	51322 X
	230	95	99.7	109	3	415 000	1 150 000	42 000	118 000	630	950	51422 X
120	155	25	—	—	1	90 000	310 000	9 150	31 500	1 600	2 400	51124
	170	39	40.8	46	1.1	141 000	430 000	14 400	44 000	1 200	1 800	51224
	210	70	74.1	80	2.1	330 000	930 000	33 500	95 000	800	1 200	51324 X
	250	102	107.3	118	4	480 000	1 400 000	49 000	142 000	600	900	51424 X
130	170	30	—	—	1	105 000	350 000	10 700	36 000	1 400	2 000	51126
	190	45	47.9	53	1.5	183 000	550 000	18 700	56 000	1 100	1 600	51226 X
	225	75	80.3	86	2.1	350 000	1 030 000	35 500	105 000	750	1 100	51326 X
	270	110	115.2	128	4	525 000	1 590 000	53 500	162 000	530	800	51426 X
140	180	31	—	—	1	107 000	375 000	11 000	38 500	1 300	2 000	51128 X
	200	46	48.6	55	1.5	186 000	575 000	18 900	59 000	1 000	1 500	51228 X
	240	80	84.9	92	2.1	370 000	1 130 000	37 500	115 000	670	1 000	51328 X
	280	112	117	131	4	550 000	1 750 000	56 500	178 000	530	800	51428 X
150	190	31	—	—	1	110 000	400 000	11 200	41 000	1 300	1 900	51130 X
	215	50	53.3	60	1.5	238 000	735 000	24 300	75 000	950	1 400	51230 X
	250	80	83.7	92	2.1	380 000	1 200 000	39 000	123 000	670	1 000	51330 X
	300	120	125.9	140	4	620 000	2 010 000	63 000	205 000	480	710	51430 X
160	200	31	—	—	1	113 000	425 000	11 500	43 500	1 200	1 900	51132 X
	225	51	54.7	61	1.5	249 000	805 000	25 400	82 000	900	1 400	51232 X
	270	87	91.7	100	3	475 000	1 570 000	48 500	160 000	600	900	51332 X
	320	130	135.3	150	5	650 000	2 210 000	66 000	226 000	450	670	51432 X
170	215	34	—	—	1.1	135 000	510 000	13 800	52 000	1 100	1 700	51134 X
	240	55	58.7	65	1.5	280 000	915 000	28 500	93 000	850	1 300	51234 X
	280	87	91.3	100	3	465 000	1 570 000	47 500	160 000	600	900	51334 X
	340	135	141	156	5	715 000	2 480 000	73 000	253 000	430	630	51434 X
180	225	34	—	—	1.1	136 000	530 000	13 800	54 000	1 100	1 700	51136 X
	250	56	58.2	66	1.5	284 000	955 000	28 900	97 000	800	1 200	51236 X
	300	95	99.3	109	3	480 000	1 680 000	49 000	171 000	560	850	51336 X
	360	140	148.3	164	5	750 000	2 730 000	76 500	278 000	400	600	51436 X
190	240	37	—	—	1.1	172 000	655 000	17 500	67 000	1 000	1 600	51138 X
	270	62	65.7	73	2	320 000	1 110 000	32 500	113 000	750	1 100	51238 X
	320	105	111	121	4	550 000	1 960 000	56 000	199 000	500	750	51338 X

Note (1) The outside diameter  $d_1$  of the shaft washers of all bearing numbers marked X is smaller than the outside diameter  $D$  of the housing washers.

Bearing Numbers <sup>(1)</sup>		Dimensions (mm)							Abutment and Fillet Dimensions (mm)			Mass(kg) approx		
With Aligning Seat	With Aligning Seat Washer	d <sub>1</sub>	D <sub>1</sub>	D <sub>2</sub>	D <sub>3</sub>	b	A	R	d <sub>a</sub> min	D <sub>a</sub> max	r <sub>a</sub> max	With Flat Seat	With Aligning Seat	With Aligning Seat Washer
—	—	145	112	—	—	—	—	—	131	124	1	1.04	—	—
53222	53222 U	160	113	135	165	14	65	125	140	130	1	2.42	2.65	3.2
53322 X	53322 XU	187	113	150	195	20.5	51	140	158	142	2	7.19	7.55	9.1
53422 X	53422 XU	225	113	170	240	29	59	180	181	159	2.5	20	20.5	24.3
—	—	155	122	—	—	—	—	—	141	134	1	1.12	—	—
53224	53224 U	170	123	145	175	15	61	125	150	140	1	2.7	2.94	3.58
53324 X	53324 XU	205	123	165	220	22	63	160	173	157	2	9.7	10.1	12.4
53424 X	53424 XU	245	123	185	260	32	70	200	196	174	3	26.2	26.5	31.3
—	—	170	132	—	—	—	—	—	154	146	1	1.68	—	—
53226 X	53226 XU	187	133	160	195	17	67	140	166	154	1.5	3.95	4.35	5.33
53326 X	53326 XU	220	134	177	235	26	53	160	186	169	2	12.1	12.7	15.8
53426 X	53426 XU	265	134	200	280	38	58	200	212	188	3	32.3	32.4	38.8
—	—	178	142	—	—	—	—	—	164	156	1	1.83	—	—
53228 X	53228 XU	197	143	170	210	17	87	160	176	164	1.5	4.3	4.74	5.89
53328 X	53328 XU	235	144	190	250	26	68	180	199	181	2	14.2	16.3	19.5
53428 X	53428 XU	275	144	206	290	38	83	225	222	198	3	34.7	34.8	41.4
—	—	188	152	—	—	—	—	—	174	166	1	1.95	—	—
53230 X	53230 XU	212	153	180	225	20.5	79	160	189	176	1.5	5.52	6.09	7.82
53330 X	53330 XU	245	154	200	260	26	89.5	200	209	191	2	15	17.3	20.5
53430 X	53430 XU	295	153	225	310	41	69	225	238	212	3	43.5	43.8	51.9
—	—	198	162	—	—	—	—	—	184	176	1	2.07	—	—
53232 X	53232 XU	222	163	190	235	21	74	160	199	186	1.5	6.04	6.78	8.7
53332 X	53332 XU	265	164	215	280	29	77	200	225	205	2.5	19.6	22.3	26.7
53432 X	53432 XU	315	164	240	330	41.5	84	250	254	226	4	52.7	52.9	62
—	—	213	172	—	—	—	—	—	197	188	1	2.72	—	—
53234 X	53234 XU	237	173	200	250	21.5	91	180	212	198	1.5	7.41	8.21	10.5
53334 X	53334 XU	275	174	220	290	29	105	225	235	215	2.5	20.3	23.2	28
53434 X	53434 XU	335	174	255	350	46	74	250	269	241	4	61.2	61.3	73
—	—	222	183	—	—	—	—	—	207	198	1	2.79	—	—
53236 X	53236 XU	247	183	210	260	21.5	112	200	222	208	1.5	7.94	8.57	10.8
53336 X	53336 XU	295	184	240	310	32	91	225	251	229	2.5	25.9	29.2	34.9
53436 X	53436 XU	355	184	270	370	46.5	97	280	285	255	4	70.5	72.1	84.9
—	—	237	193	—	—	—	—	—	220	210	1	3.6	—	—
53238 X	53238 XU	267	194	230	280	23	98	200	238	222	2	11.8	12.9	15.7
53338 X	53338 XU	315	195	255	330	33	104	250	266	244	3	36.5	38.1	44.7

# SINGLE-DIRECTION THRUST BALL BEARINGS

Bore Diameter 200~360 mm

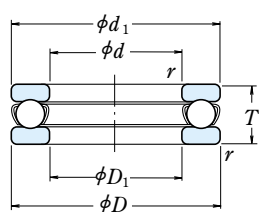

With Flat Seat

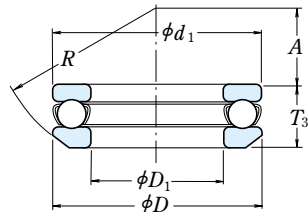

With Aligning Seat

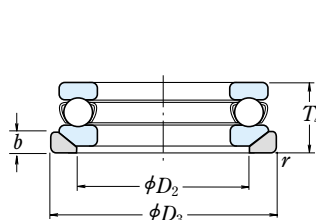

With Aligning Seat Washer

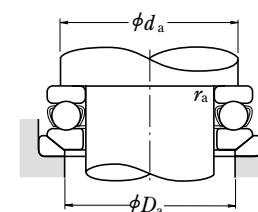
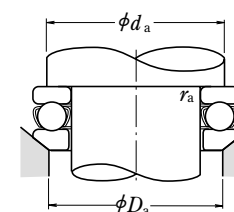
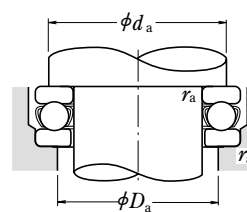

Boundary Dimensions (mm)						Basic Load Ratings (N)				Limiting Speeds (rpm)		With Flat Seat
$d$	$D$	$T$	$T_3$	$T_4$	$r_{min}$	$C_a$	$C_{0a}$	$C_a$	$C_{0a}$	Grease	Oil	
<b>200</b>	250	37	—	—	1.1	173 000	675 000	17 600	69 000	1 000	1 500	<b>51140 X</b>
	280	62	65.3	74	2	315 000	1 110 000	32 500	113 000	710	1 100	<b>51240 X</b>
	340	110	118.4	130	4	600 000	2 220 000	61 500	227 000	480	710	<b>51340 X</b>
<b>220</b>	270	37	—	—	1.1	179 000	740 000	18 200	75 500	950	1 500	<b>51144 X</b>
	300	63	65.6	75	2	325 000	1 210 000	33 500	123 000	670	1 000	<b>51244 X</b>
<b>240</b>	300	45	—	—	1.5	229 000	935 000	23 400	95 000	850	1 200	<b>51148 X</b>
	340	78	81.6	92	2.1	420 000	1 650 000	43 000	168 000	560	850	<b>51248 X</b>
<b>260</b>	320	45	—	—	1.5	233 000	990 000	23 800	101 000	800	1 200	<b>51152 X</b>
	360	79	82.8	93	2.1	435 000	1 800 000	44 500	184 000	560	850	<b>51252 X</b>
<b>280</b>	350	53	—	—	1.5	315 000	1 310 000	32 000	134 000	710	1 000	<b>51156 X</b>
	380	80	85	94	2.1	450 000	1 950 000	46 000	199 000	530	800	<b>51256 X</b>
<b>300</b>	380	62	—	—	2	360 000	1 560 000	36 500	159 000	600	900	<b>51160 X</b>
	420	95	100.5	112	3	540 000	2 410 000	55 000	246 000	450	670	<b>51260 X</b>
<b>320</b>	400	63	—	—	2	365 000	1 660 000	37 500	169 000	600	900	<b>51164 X</b>
	440	95	100.5	112	3	585 000	2 680 000	59 500	273 000	450	670	<b>51264 X</b>
<b>340</b>	420	64	—	—	2	375 000	1 760 000	38 500	179 000	560	850	<b>51168 X</b>
	460	96	100.3	113	3	595 000	2 800 000	60 500	285 000	430	630	<b>51268 X</b>
<b>360</b>	440	65	—	—	2	385 000	1 860 000	39 000	190 000	560	800	<b>51172 X</b>
	500	110	116.7	130	4	705 000	3 500 000	72 000	355 000	380	560	<b>51272 X</b>

**Note** (1) The outside diameter  $d_1$  of the shaft washers of all bearing numbers marked X is smaller than the outside diameter  $D$  of the housing washers.

Bearing Numbers <sup>(1)</sup>		Dimensions (mm)							Abutment and Fillet Dimensions (mm)			Mass(kg) approx		
With Aligning Seat	With Aligning Seat Washer	$d_1$	$D_1$	$D_2$	$D_3$	$b$	$A$	$R$	$d_a$ min	$D_a$ max	$r_a$ max	With Flat Seat	With Aligning Seat	With Aligning Seat Washer
—	—	247	203	—	—	—	—	—	230	220	1	3.75	—	—
<b>53240 X</b>	<b>53240 XU</b>	277	204	240	290	23	125	225	248	232	2	12.3	13.4	16.1
<b>53340 X</b>	<b>53340 XU</b>	335	205	270	350	38	92	250	282	258	3	43.6	46.2	54.8
—	—	267	223	—	—	—	—	—	250	240	1	4.09	—	—
<b>53244 X</b>	<b>53244 XU</b>	297	224	260	310	25	118	225	268	252	2	13.6	14.9	18
—	—	297	243	—	—	—	—	—	276	264	1.5	6.55	—	—
<b>53248 X</b>	<b>53248 XU</b>	335	244	290	350	30	122	250	299	281	2	23.7	25.6	30.7
—	—	317	263	—	—	—	—	—	296	284	1.5	7.01	—	—
<b>53252 X</b>	<b>53252 XU</b>	355	264	305	370	30	152	280	319	301	2	25.1	27.3	33.2
—	—	347	283	—	—	—	—	—	322	308	1.5	12	—	—
<b>53256 X</b>	<b>53256 XU</b>	375	284	325	390	31	143	280	339	321	2	27.1	30.3	37
—	—	376	304	—	—	—	—	—	348	332	2	17.2	—	—
<b>53260 X</b>	<b>53260 XU</b>	415	304	360	430	34	164	320	371	349	2.5	43.5	47.7	56.1
—	—	396	324	—	—	—	—	—	368	352	2	18.6	—	—
<b>53264 X</b>	<b>53264 XU</b>	435	325	380	450	36	157	320	391	369	2.5	45	49.9	59.4
—	—	416	344	—	—	—	—	—	388	372	2	19.9	—	—
<b>53268 X</b>	<b>53268 XU</b>	455	345	400	470	36	199	360	411	389	2.5	47.9	52.7	62
—	—	436	364	—	—	—	—	—	408	392	2	21.5	—	—
<b>53272 X</b>	<b>53272 XU</b>	495	365	430	510	43	172	360	442	418	3	68.8	76.3	90.9





Bore Diameter 60~130 mm

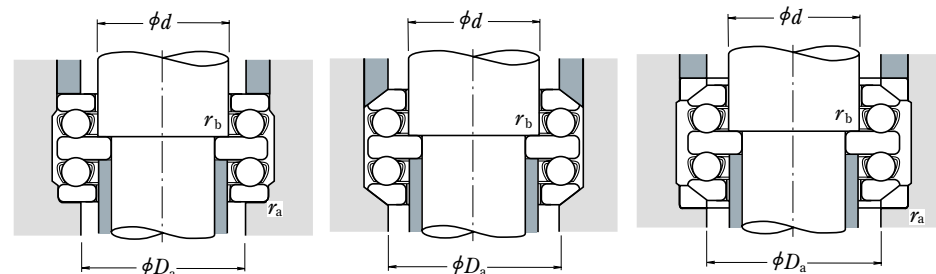
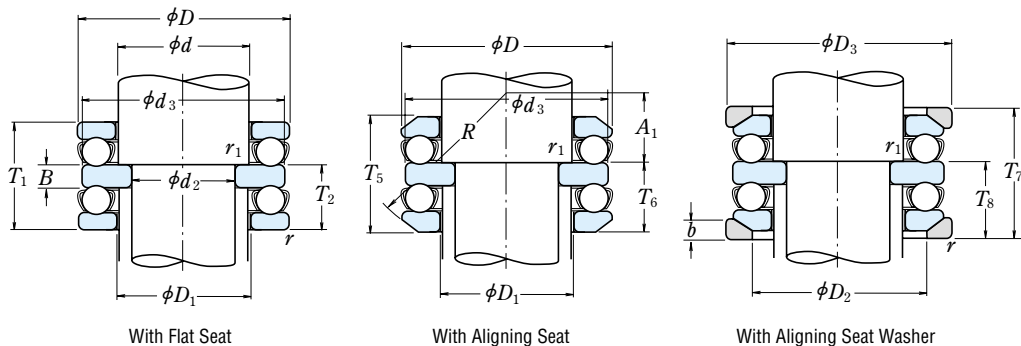

$d_2$	Boundary Dimensions (mm)							Basic Load Ratings (N)				Limiting Speeds (rpm)		Bearing Numbers <sup>(1)</sup>	
	$d$	$D$	$T_1$	$T_5$	$T_7$	$r_{min}$	$r_{1min}$	$C_a$	$C_{0a}$	$C_a$	$C_{0a}$	Grease	Oil	With Flat Seat	With Aligning Seat
60	75	110	47	49.6	57	1	1	78 000	209 000	7 950	21 300	1 800	2 600	<b>52215</b>	<b>54215</b>
	75	135	79	87.2	95	1.5	1	159 000	365 000	16 200	37 500	1 200	1 800	<b>52315</b>	<b>54315</b>
	75	160	115	123	135	2	1	254 000	560 000	25 900	57 000	900	1 400	<b>52415</b>	<b>54415</b>
65	80	115	48	51	58	1	1	79 000	218 000	8 050	22 300	1 700	2 600	<b>52216</b>	<b>54216</b>
	80	140	79	86.2	95	1.5	1	164 000	395 000	16 700	40 000	1 200	1 800	<b>52316</b>	<b>54316</b>
	80	170	120	128.4	140	2.1	1	272 000	620 000	27 800	63 500	850	1 300	<b>52416</b>	<b>54416</b>
	85	180	128	138	150	2.1	1.1	310 000	755 000	31 500	77 000	800	1 200	<b>52417 X</b>	<b>54417 X</b>
70	85	125	55	59.2	67	1	1	96 000	264 000	9 800	26 900	1 500	2 200	<b>52217</b>	<b>54217</b>
	85	150	87	95.2	105	1.5	1	207 000	490 000	21 100	50 000	1 100	1 600	<b>52317</b>	<b>54317</b>
	90	190	135	143.4	157	2.1	1.1	330 000	825 000	33 500	84 000	750	1 100	<b>52418 X</b>	<b>54418 X</b>
75	90	135	62	69	76	1.1	1	114 000	310 000	11 600	31 500	1 400	2 000	<b>52218</b>	<b>54218</b>
	90	155	88	97.2	106	1.5	1	214 000	525 000	21 900	53 500	1 100	1 600	<b>52318</b>	<b>54318</b>
80	100	210	150	160	176	3	1.1	370 000	985 000	38 000	100 000	670	1 000	<b>52420 X</b>	<b>54420 X</b>
	100	150	67	72.8	81	1.1	1	135 000	375 000	13 700	38 500	1 300	1 900	<b>52220</b>	<b>54220</b>
85	100	170	97	105.4	115	1.5	1	239 000	595 000	24 300	61 000	950	1 500	<b>52320</b>	<b>54320</b>
	110	230	166	—	—	3	1.1	415 000	1 150 000	42 000	118 000	600	900	<b>52422 X</b>	—
95	110	160	67	71.4	81	1.1	1	136 000	395 000	13 900	40 000	1 200	1 800	<b>52222</b>	<b>54222</b>
	110	190	110	118.4	128	2	1	282 000	755 000	28 800	77 000	850	1 300	<b>52322 X</b>	<b>54322 X</b>
	120	250	177	—	—	4	1.5	515 000	1 540 000	52 500	157 000	560	850	<b>52424 X</b>	—
100	120	170	68	71.6	82	1.1	1.1	141 000	430 000	14 400	44 000	1 200	1 800	<b>52224</b>	<b>54224</b>
	120	210	123	131.2	143	2.1	1.1	330 000	930 000	33 500	95 000	750	1 100	<b>52324 X</b>	<b>54324 X</b>
	130	270	192	—	—	4	1.5	525 000	1 590 000	53 500	162 000	530	800	<b>52426 X</b>	—
110	130	190	80	85.8	96	1.5	1.1	183 000	550 000	18 700	56 000	1 000	1 500	<b>52226 X</b>	<b>54226 X</b>
	130	225	130	—	—	2.1	1.1	350 000	1 030 000	35 500	105 000	710	1 100	<b>52326 X</b>	—
	140	280	196	—	—	4	1.5	550 000	1 750 000	56 500	178 000	500	750	<b>52428 X</b>	—
120	140	200	81	86.2	99	1.5	1.1	186 000	575 000	18 900	59 000	1 000	1 500	<b>52228 X</b>	<b>54228 X</b>
	140	240	140	—	—	2.1	1.1	370 000	1 130 000	37 500	115 000	670	1 000	<b>52328 X</b>	—
	150	300	209	—	—	4	2	620 000	2 010 000	63 000	205 000	480	710	<b>52430 X</b>	—
130	150	215	89	95.6	109	1.5	1.1	238 000	735 000	24 300	75 000	900	1 300	<b>52230 X</b>	<b>54230 X</b>
	150	250	140	—	—	2.1	1.1	380 000	1 200 000	39 000	123 000	630	950	<b>52330 X</b>	—
	160	320	226	—	—	5	2	650 000	2 210 000	66 000	226 000	430	630	<b>52432 X</b>	—

Note (1) The outside diameter  $d_3$  of the central washers of all bearing numbers marked X is smaller than the outside diameter  $D$  of the housing washers.

With Aligning Seat Washer	Dimensions (mm)										Abutment and Fillet Dimensions (mm)			Mass(kg) approx			
	$d_3$	$D_1$	$D_2$	$D_3$	$T_2$	$T_6$	$T_8$	$B$	$b$	$A_1$	$R$	$D_a$	$r_a$	$r_b$	With Flat Seat	With Aligning Seat	With Aligning Seat Washer
<b>54215 U</b>	110	77	92	115	28.5	29.8	33.5	10	9.5	47.5	90	92	1	1	1.54	1.66	2.06
<b>54315 U</b>	135	77	105	140	48.5	52.6	56.5	18	15	32.5	100	105	1.5	1	4.74	5.14	6.38
<b>54415 U</b>	160	78	115	165	70.5	74.5	80.5	26	21	36.5	125	115	2	1	10.8	11	13.7
<b>54216 U</b>	115	82	98	120	29	30.5	34	10	10	45	90	98	1	1	1.66	1.78	2.21
<b>54316 U</b>	140	82	110	145	48.5	52.1	56.5	18	15	45.5	112	110	1.5	1	4.99	5.39	6.61
<b>54416 U</b>	170	83	125	175	73.5	77.7	83.5	27	22	30.5	125	125	2	1	12.6	12.8	16
<b>54417 XU</b>	179.5	88	130	185	78.5	83.5	89.5	29	23	40.5	140	130	2	1	15.4	15.8	19.5
<b>54217 U</b>	125	88	105	130	33.5	35.6	39.5	12	11	49.5	100	105	1	1	2.26	2.45	3.02
<b>54317 U</b>	150	88	115	155	53	57.1	62	19	17.5	39	112	115	1.5	1	6.38	6.8	10.5
<b>54418 XU</b>	189.5	93	140	195	82.5	86.7	93.5	30	25.5	34.5	140	140	2	1	17.5	18.1	22.5
<b>54218 U</b>	135	93	110	140	38	41.5	45	14	13.5	42	100	110	1	1	3.09	3.42	4.39
<b>54318 U</b>	155	93	120	160	53.5	58.1	62.5	19	18	36.5	112	120	1.5	1	6.79	7.33	9.29
<b>54420 XU</b>	209.5	103	155	220	91.5	96.5	104.5	33	27	43.5	160	155	2.5	1	26.8	27.2	33.4
<b>54220 U</b>	150	103	125	155	41	43.9	48	15	14	49	112	125	1	1	4.08	4.54	5.64
<b>54320 U</b>	170	103	135	175	59	63.2	68	21	18	42	125	135	1.5	1	8.82	9.47	11.6
—	229	113	—	—	101.5	—	—	37	—	—	—	159	2.5	1	35.6	—	—
<b>54222 U</b>	160	113	135	165	41	43.2	48	15	14	62	125	135	1	1	4.39	4.83	5.94
<b>54322 XU</b>	189.5	113	150	195	67	71.2	76	24	20.5	47	140	150	2	1	12.7	13.5	16.6
—	249	123	—	—	108.5	—	—	40	—	—	—	174	3	1.5	47.6	—	—
<b>54224 U</b>	170	123	145	175	41.5	43.3	48.5	15	15	58.5	125	145	1	1	4.92	5.4	6.68
<b>54324 XU</b>	209.5	123	165	220	75	79.1	85	27	22	58	160	165	2	1	17.6	16.4	22.9
—	269	134	—	—	117	—	—	42	—	—	—	188	3	1.5	57.8	—	—
<b>54226 XU</b>	189.5	133	160	195	49	51.9	57	18	17	63	140	160	1.5	1	7.43	8.24	10.2
—	224	134	—	—	80	—	—	30	—	—	—	169	2	1	21.5	—	—
—	279	144	—	—	120	—	—	44	—	—	—	198	3	1.5	62.4	—	—
<b>54228 XU</b>	199.5	143	170	210	49.5	52.1	58.5	18	17	83.5	160	170	1.5	1	8.01	8.87	11.2
—	239	144	—	—	85.5	—	—	31	—	—	—	181	2	1	24.8	—	—
—	299	153	—	—	127.5	—	—	46	—	—	—	212	3	2	77.8	—	—
<b>54230 XU</b>	214.5	153	180	225	54.5	57.8	64.5	20	20.5	74.5	160	180	1.5	1	10.4	11.5	15
—	249	154	—	—	85.5	—	—	31	—	—	—	191	2	1	30.3	—	—
—	319	164	—	—	138	—	—	50	—	—	—	226	4	2	93.6	—	—

Bore Diameter 135~190 mm

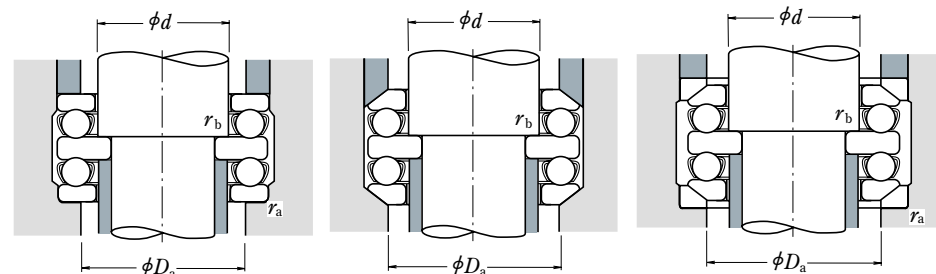
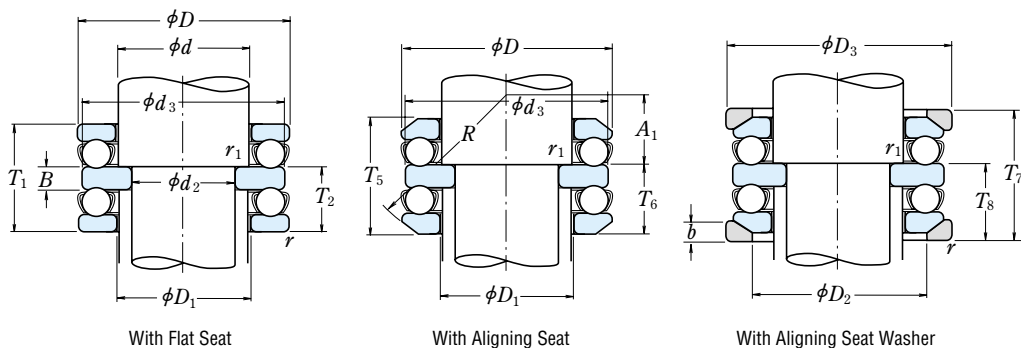

Bore Diameter (mm)	Boundary Dimensions (mm)								Basic Load Ratings (N)				Limiting Speeds (rpm)		Bearing Numbers <sup>(1)</sup>	
	$d_2$	$d$	$D$	$T_1$	$T_5$	$T_7$	$r_{min}$	$r_{1min}$	$C_a$	$C_{0a}$	$C_a$	$C_{0a}$	Grease	Oil	With Flat Seat	With Aligning Seat
135	170	340	236	—	—	5	2.1	715 000	2 480 000	73 000	253 000	400	600	<b>52434 X</b>	—	
140	160	225	90	97.4	110	1.5	1.1	249 000	805 000	25 400	82 000	850	1 300	<b>52232 X</b>	<b>54232 X</b>	
	160	270	153	—	—	3	1.1	475 000	1 570 000	48 500	160 000	600	900	<b>52332 X</b>	—	
	180	360	245	—	—	5	3	750 000	2 730 000	76 500	278 000	380	560	<b>52436 X</b>	—	
150	170	240	97	104.4	117	1.5	1.1	280 000	915 000	28 500	93 000	800	1 200	<b>52234 X</b>	<b>54234 X</b>	
	170	280	153	—	—	3	1.1	465 000	1 570 000	47 500	160 000	560	850	<b>52334 X</b>	—	
	180	250	98	102.4	118	1.5	2	284 000	955 000	28 900	97 000	800	1 200	<b>52236 X</b>	<b>54236 X</b>	
	180	300	165	—	—	3	3	480 000	1 680 000	49 000	171 000	530	800	<b>52336 X</b>	—	
160	190	270	109	116.4	131	2	2	320 000	1 110 000	32 500	113 000	710	1 100	<b>52238 X</b>	<b>54238 X</b>	
	190	320	183	—	—	4	2	550 000	1 960 000	56 000	199 000	480	710	<b>52338 X</b>	—	
170	200	280	109	115.6	133	2	2	315 000	1 110 000	32 500	113 000	710	1 000	<b>52240 X</b>	<b>54240 X</b>	
	200	340	192	—	—	4	2	600 000	2 220 000	61 500	227 000	450	670	<b>52340 X</b>	—	
190	220	300	110	115.2	134	2	2	325 000	1 210 000	33 500	123 000	670	1 000	<b>52244 X</b>	<b>54244 X</b>	

Note <sup>(1)</sup> The outside diameter  $d_3$  of the central washers of all bearing numbers marked X is smaller than the outside diameter  $D$  of the housing washers.

Bearing Number	Dimensions (mm)											Abutment and Fillet Dimensions (mm)			Mass(kg) approx		
	$d_3$	$D_1$	$D_2$	$D_3$	$T_2$	$T_6$	$T_8$	$B$	$b$	$A_1$	$R$	$D_{a max}$	$r_{a max}$	$r_{b max}$	With Flat Seat	With Aligning Seat	With Aligning Seat Washer
—	339	174	—	—	143	—	—	50	—	—	—	240	4	2	110	—	—
<b>54232 XU</b>	224.5	163	190	235	55	58.7	65	20	21	70	160	190	1.5	1	11.2	12.7	16.5
	—	269	164	—	93	—	—	33	—	—	—	205	2.5	1	35.1	—	—
	—	359	184	—	148.5	—	—	52	—	—	—	254	4	2.5	126	—	—
<b>54234 XU</b>	239.5	173	200	250	59	62.7	69	21	21.5	87	180	200	1.5	1	13.6	15.2	19.8
	—	279	174	—	93	—	—	33	—	—	—	215	2.5	1	40.8	—	—
<b>54236 XU</b>	249	183	210	260	59.5	61.7	69.5	21	21.5	108.5	200	210	1.5	2	14.8	16.1	20.6
	—	299	184	—	101	—	—	37	—	—	—	229	2.5	2.5	46.3	—	—
<b>54238 XU</b>	269	194	230	280	66.5	70.2	77.5	24	23	93.5	200	230	2	2	22.1	22.2	29.8
	—	319	195	—	111.5	—	—	40	—	—	—	244	3	2	113	—	—
<b>54240 XU</b>	279	204	240	290	66.5	69.8	78.5	24	23	120.5	225	240	2	2	23.1	23.2	30.6
	—	339	205	—	117	—	—	42	—	—	—	258	3	2	78.4	—	—
<b>54244 XU</b>	299	224	260	310	67	69.6	79	24	25	114	225	260	2	2	25.2	27.8	34.1

Bore Diameter 35~130 mm

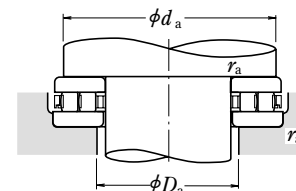
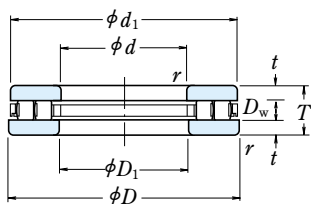

Boundary Dimensions (mm)				Basic Load Ratings (N)		Limiting Speeds (rpm)	
$d$	$D$	$T$	$r_{min}$	$C_a$	$C_{0a}$	Grease	Oil
<b>35</b>	80	32	1.1	95 000	247 000	1 000	3 000
<b>40</b>	78	22	1	63 000	194 000	1 200	3 600
<b>45</b>	65	14	0.6	33 000	100 000	1 700	5 000
	85	24	1	71 000	233 000	1 100	3 400
<b>50</b>	110	27	1.1	139 000	470 000	900	2 800
	95	27	1.1	113 000	350 000	1 000	3 000
<b>55</b>	105	30	1.1	134 000	450 000	900	2 600
<b>60</b>	95	26	1	99 000	325 000	1 000	3 000
	110	30	1.1	139 000	480 000	850	2 600
<b>65</b>	100	27	1	110 000	325 000	950	2 800
	115	30	1.1	145 000	515 000	850	2 600
<b>70</b>	150	36	2	259 000	935 000	670	2 000
	125	34	1.1	191 000	635 000	750	2 200
<b>75</b>	100	19	1	63 500	221 000	1 100	3 400
	135	36	1.5	209 000	735 000	710	2 200
<b>80</b>	115	28	1	120 000	420 000	900	2 600
	140	36	1.5	208 000	740 000	710	2 000
<b>85</b>	110	19	1	75 000	298 000	1 100	3 200
	125	31	1	151 000	485 000	800	2 400
	150	39	1.5	257 000	995 000	630	1 900
<b>90</b>	120	22	1	96 000	370 000	950	3 000
	155	39	1.5	250 000	885 000	630	1 900
<b>100</b>	170	42	1.5	292 000	1 110 000	560	1 700
<b>110</b>	160	38	1.1	228 000	855 000	630	1 900
	190	48	2	390 000	1 490 000	500	1 500
<b>120</b>	170	39	1.1	233 000	895 000	600	1 800
	210	54	2.1	505 000	1 930 000	450	1 400
<b>130</b>	190	45	1.5	300 000	1 090 000	530	1 600
	225	58	2.1	585 000	2 370 000	430	1 300
	270	85	4	895 000	3 300 000	320	950

Bearing Numbers	Dimensions (mm)				Abutment and Fillet Dimensions (mm)			Mass (kg) approx
	$d_1$	$D_1$	$D_w$	$t$	$d_{a min}$	$D_{a max}$	$r_{a max}$	
<b>35 TMP 14</b>	80	37	12	10	71	46	1	0.97
<b>40 TMP 93</b>	78	42	8	7	71	48	1	0.525
<b>45 TMP 11</b>	65	47	6	4	60	49	0.6	0.144
<b>45 TMP 93</b>	85	47	8	8	78	53	1	0.665
<b>50 TMP 74</b>	109	52	11	8	100	61	1	1.52
<b>50 TMP 93</b>	93	52	11	8	89	57	1	0.94
<b>55 TMP 93</b>	105	55.2	11	9.5	98	63	1	1.28
<b>60 TMP 12</b>	95	62	10	8	88	67	1	0.735
<b>60 TMP 93</b>	110	62	11	9.5	103	68	1	1.36
<b>65 TMP 12</b>	100	67	12.5	7.25	93	71	1	0.805
<b>65 TMP 93</b>	115	65.2	11	9.5	108	73	1	1.44
<b>70 TMP 74</b>	149	72	15	10.5	137	84	2	3.8
<b>70 TMP 93</b>	125	72	14	10	117	78	1	1.95
<b>75 TMP 11</b>	100	77	8	5.5	96	79	1	0.41
<b>75 TMP 93</b>	135	77	14	11	125	84	1.5	2.42
<b>80 TMP 12</b>	115	82	11	8.5	109	86	1	1.02
<b>80 TMP 93</b>	138	82	14	11	130	91	1.5	2.54
<b>85 TMP 11</b>	110	87	7.5	5.75	105	89	1	0.46
<b>85 TMP 12</b>	125	88	14	8.5	118	92	1	1.36
<b>85 TMP 93</b>	148	87	14	12.5	140	95	1.5	3.2
<b>90 TMP 11</b>	119	91.5	9	6.5	114	95	1	0.725
<b>90 TMP 93</b>	155	90.2	16	11.5	144	101	1.5	3.3
<b>100 TMP 93</b>	170	103	16	13	159	110	1.5	4.25
<b>110 TMP 12</b>	160	113	15	11.5	150	119	1	2.66
<b>110 TMP 93</b>	190	113	19	14.5	179	120	2	6.15
<b>120 TMP 12</b>	170	123	15	12	160	129	1	2.93
<b>120 TMP 93</b>	210	123	22	16	199	129	2	8.55
<b>130 TMP 12</b>	187	133	19	13	177	142	1.5	4.5
<b>130 TMP 93</b>	225	133	22	18	214	140	2	10.4
<b>130 TMP 94</b>	270	133	32	26.5	254	150	3	26.2

Remarks For cylindrical roller thrust bearings not listed above, please contact NSK.

Bore Diameter 140~320 mm

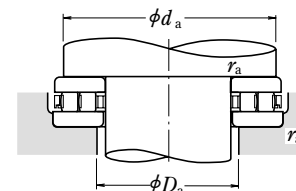
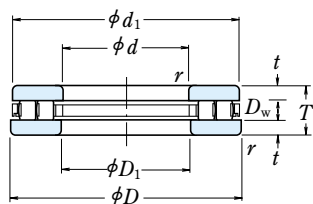

<i>d</i>	Boundary Dimensions (mm)			Basic Load Ratings (N)		Limiting Speeds (rpm)	
	<i>D</i>	<i>T</i>	<i>r</i> <sub>min</sub>	<i>C</i> <sub>a</sub>	<i>C</i> <sub>0a</sub>	Grease	Oil
<b>140</b>	200	46	2	285 000	1 120 000	500	1 500
	240	60	2.1	610 000	2 360 000	400	1 200
	280	85	4	990 000	3 800 000	300	900
<b>150</b>	215	50	2	375 000	1 500 000	480	1 400
	250	60	2.1	635 000	2 510 000	400	1 200
<b>160</b>	200	31	1	173 000	815 000	630	1 900
	270	67	3	745 000	3 150 000	360	1 100
<b>170</b>	240	55	1.5	485 000	1 960 000	430	1 300
	280	67	3	800 000	3 500 000	340	1 000
<b>180</b>	300	73	3	1 000 000	4 000 000	320	950
	360	109	5	1 640 000	6 200 000	240	710
<b>190</b>	270	62	3	705 000	2 630 000	360	1 100
	320	78	4	1 080 000	4 500 000	300	900
<b>200</b>	250	37	1.1	365 000	1 690 000	500	1 500
	340	85	4	1 180 000	5 150 000	280	800
<b>220</b>	270	37	1.1	385 000	1 860 000	480	1 500
	300	63	2	770 000	3 100 000	340	1 000
<b>240</b>	300	45	1.5	435 000	2 160 000	400	1 200
	340	78	2.1	965 000	4 100 000	280	850
<b>260</b>	320	45	1.5	460 000	2 350 000	400	1 200
	360	79	2.1	995 000	4 350 000	280	850
<b>280</b>	350	53	1.5	545 000	2 800 000	340	1 000
	380	80	2.1	1 050 000	4 750 000	260	800
<b>300</b>	380	62	2	795 000	4 000 000	300	900
	420	95	3	1 390 000	6 250 000	220	670
<b>320</b>	400	63	2	820 000	4 250 000	300	900
	440	95	3	1 420 000	6 550 000	220	670

Bearing Numbers	Dimensions (mm)				Abutment and Fillet Dimensions (mm)			Mass (kg) approx
	<i>d</i> <sub>1</sub>	<i>D</i> <sub>1</sub>	<i>D</i> <sub>w</sub>	<i>t</i>	<i>d</i> <sub>a min</sub>	<i>D</i> <sub>a max</sub>	<i>r</i> <sub>a max</sub>	
<b>140 TMP 12</b>	197	143	17	14.5	188	153	2	4.85
<b>140 TMP 93</b>	240	143	25	17.5	226	154	2	12.2
<b>140 TMP 94</b>	280	143	32	26.5	262	158	3	27.5
<b>150 TMP 12</b>	215	153	19	15.5	202	163	2	6.15
<b>150 TMP 93</b>	250	153	25	17.5	236	165	2	12.8
<b>160 TMP 11</b>	200	162	11	10	191	168	1	2.21
<b>160 TMP 93</b>	265	164	25	21	255	173	2.5	16.9
<b>170 TMP 12</b>	237	173	22	16.5	227	182	1.5	8.2
<b>170 TMP 93</b>	280	173	25	21	265	183	2.5	17.7
<b>180 TMP 93</b>	300	185	32	20.5	284	194	2.5	22.5
<b>180 TMP 94</b>	354	189	45	32	335	205	4	58.2
<b>190 TMP 12</b>	266	195	30	16	255	200	2.5	11.8
<b>190 TMP 93</b>	320	195	32	23	303	205	3	27.6
<b>200 TMP 11</b>	247	203	17	10	242	207	1	4.1
<b>200 TMP 93</b>	340	205	32	26.5	322	218	3	34.5
<b>220 TMP 11</b>	267	223	17	10	262	227	1	4.5
<b>220 TMP 12</b>	297	224	30	16.5	287	232	2	13.5
<b>240 TMP 11</b>	297	243	18	13.5	288	251	1.5	7.2
<b>240 TMP 12</b>	335	244	32	23	322	258	2	23.3
<b>260 TMP 11</b>	317	263	18	13.5	308	272	1.5	7.75
<b>260 TMP 12</b>	355	264	32	23.5	342	276	2	25.2
<b>280 TMP 11</b>	347	283	20	16.5	335	294	1.5	11.6
<b>280 TMP 12</b>	375	284	32	24	362	296	2	27.2
<b>300 TMP 11</b>	376	304	25	18.5	365	315	2	16.7
<b>300 TMP 12</b>	415	304	38	28.5	398	322	2.5	42
<b>320 TMP 11</b>	396	324	25	19	385	335	2	18
<b>320 TMP 12</b>	435	325	38	28.5	418	340	2.5	44.5

Remarks For cylindrical roller thrust bearings not listed above, please contact NSK.

Bore Diameter 60~200 mm

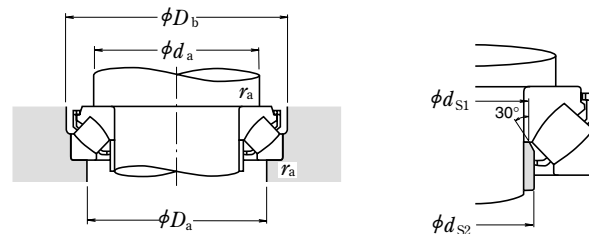
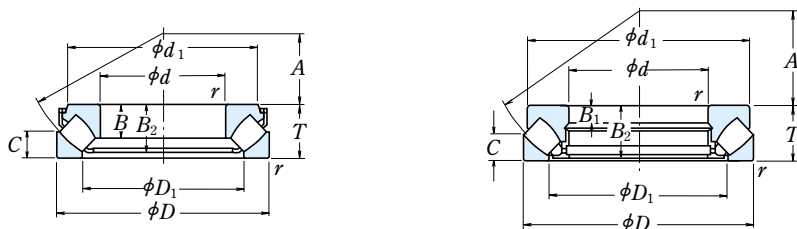

**Dynamic Equivalent Load**

$$P = 1.2F_r + F_a$$

**Static Equivalent Load**

$$P_0 = 2.8F_r + F_a$$

However,  $F_r/F_a \leq 0.55$  must be satisfied.

Boundary Dimensions (mm)				Basic Load Ratings				Limiting Speeds (rpm) Oil	Bearing Numbers
<i>d</i>	<i>D</i>	<i>T</i>	<i>r</i> <sub>min</sub>	<i>C</i> <sub>a</sub> (N)	<i>C</i> <sub>0a</sub>	<i>C</i> (kgf)			
<b>60</b>	130	42	1.5	330 000	885 000	33 500	90 000	2 600	<b>29412 E</b>
<b>65</b>	140	45	2	405 000	1 100 000	41 500	112 000	2 400	<b>29413 E</b>
<b>70</b>	150	48	2	450 000	1 240 000	46 000	126 000	2 400	<b>29414 E</b>
<b>75</b>	160	51	2	515 000	1 430 000	52 500	146 000	2 200	<b>29415 E</b>
<b>80</b>	170	54	2.1	575 000	1 600 000	58 500	163 000	2 000	<b>29416 E</b>
<b>85</b>	150	39	1.5	330 000	1 040 000	34 000	106 000	2 400	<b>29317 E</b>
	180	58	2.1	630 000	1 760 000	64 500	179 000	1 900	<b>29417 E</b>
<b>90</b>	155	39	1.5	350 000	1 080 000	35 500	110 000	2 200	<b>29318 E</b>
	190	60	2.1	695 000	1 950 000	70 500	199 000	1 800	<b>29418 E</b>
<b>100</b>	170	42	1.5	410 000	1 280 000	41 500	131 000	2 000	<b>29320 E</b>
	210	67	3	840 000	2 400 000	86 000	245 000	1 600	<b>29420 E</b>
<b>110</b>	190	48	2	530 000	1 710 000	54 000	174 000	1 800	<b>29322 E</b>
	230	73	3	1 010 000	2 930 000	103 000	299 000	1 500	<b>29422 E</b>
<b>120</b>	210	54	2.1	645 000	2 100 000	65 500	214 000	1 600	<b>29324 E</b>
	250	78	4	1 160 000	3 400 000	119 000	350 000	1 400	<b>29424 E</b>
<b>130</b>	225	58	2.1	740 000	2 450 000	75 500	250 000	1 500	<b>29326 E</b>
	270	85	4	1 330 000	3 900 000	135 000	400 000	1 200	<b>29426 E</b>
<b>140</b>	240	60	2.1	840 000	2 810 000	85 500	287 000	1 400	<b>29328 E</b>
	280	85	4	1 370 000	4 200 000	140 000	425 000	1 200	<b>29428 E</b>
<b>150</b>	250	60	2.1	870 000	2 900 000	89 000	296 000	1 400	<b>29330 E</b>
	300	90	4	1 580 000	4 900 000	162 000	500 000	1 100	<b>29430 E</b>
<b>160</b>	270	67	3	1 010 000	3 400 000	103 000	345 000	1 300	<b>29332 E</b>
	320	95	5	1 740 000	5 400 000	178 000	550 000	1 100	<b>29432 E</b>
<b>170</b>	280	67	3	1 050 000	3 500 000	107 000	355 000	1 200	<b>29334 E</b>
	340	103	5	1 680 000	5 800 000	171 000	595 000	1 000	<b>29434 E</b>
<b>180</b>	300	73	3	1 230 000	4 200 000	125 000	430 000	1 100	<b>29336 E</b>
	360	109	5	1 870 000	6 500 000	190 000	660 000	900	<b>29436 E</b>
<b>190</b>	320	78	4	1 370 000	4 700 000	140 000	480 000	1 100	<b>29338 E</b>
	380	115	5	2 100 000	7 450 000	215 000	760 000	850	<b>29438 E</b>
<b>200</b>	280	48	2	540 000	2 310 000	55 000	236 000	1 500	<b>29240</b>
	340	85	4	1 570 000	5 450 000	160 000	555 000	1 000	<b>29340 E</b>
	400	122	5	2 290 000	8 150 000	234 000	835 000	800	<b>29440</b>

Dimensions (mm)						Spacer Sleeve Dimensions (mm)		Abutment and Fillet Dimensions (mm)				Mass (kg) approx
<i>d</i> <sub>1</sub>	<i>D</i> <sub>1</sub>	<i>B</i> , <i>B</i> <sub>1</sub>	<i>B</i> <sub>2</sub>	<i>C</i>	<i>A</i>	<i>d</i> <sub>S1</sub> max	<i>d</i> <sub>S2</sub> max	<i>d</i> <sub>a</sub> ( <sup>1</sup> ) min	<i>D</i> <sub>a</sub> max	<i>D</i> <sub>b</sub> min	<i>r</i> <sub>a</sub> max	
114.5	89	27	38	20	38	67	67	90	108	133	1.5	2.55
121.5	93	29.5	40.5	22	42	72	72	100	115	143	2	3.2
131.5	102	31	43	24	44	78	78	105	125	153	2	3.9
138	107	33.5	46	25	47	83	83	115	132	163	2	4.65
148	114.5	35	48.5	27	50	89	89	120	140	173	2	5.55
134.5	112	24.5	35.5	19	50	91	91	115	135	153	1.5	2.7
156.5	124	37	51.5	28	54	95	95	130	150	183	2	6.55
139.5	118	24.5	35	19	52	97	97	120	140	158	1.5	2.83
165.5	129.5	39	54.5	29	56	100	100	135	157	193	2	7.55
152	128	26.2	38	20.8	58	107	107	130	150	173	1.5	3.6
185	144	43	59.5	33	62	111	111	150	175	214	2.5	10.3
169.5	142.5	30.3	43.5	24	64	117	117	145	165	193	2	5.25
200	157	47	64.5	36	69	121	129	165	190	234	2.5	13.3
187.5	156.5	34	48.5	27	70	130	130	160	180	214	2	7.3
215	171	50.5	69.5	38	74	132	142	180	205	254	3	16.6
203.5	168.5	37	53.5	28	76	141	143	170	195	229	2	8.95
235	185	54	74.5	42	81	143	153	195	225	275	3	21.1
216.5	179	38.5	54	30	82	148	154	185	205	244	2	10.4
244.5	195.5	54	74.5	42	86	153	162	205	235	285	3	22.2
224	190	38	54.5	29	87	158	163	195	215	254	2	10.8
266	209	58	81	44	92	164	175	220	250	306	3	27.3
243	203	42	60	33	92	169	176	210	235	275	2.5	14.3
278	224.5	60.5	84.5	46	99	175	189	230	265	326	4	32.1
252	214.5	42.2	60.5	32	96	178	188	220	245	285	2.5	14.8
310	243	37	99	50	104	—	—	245	285	—	4	43.5
270	227	46	65.5	36	103	189	195	235	260	306	2.5	19
330	255	39	105	52	110	—	—	260	300	—	4	52
288.5	244	49	69	38	110	200	211	250	275	326	3	23
345	271	41	111	55	117	—	—	275	320	—	4	60
266	236	15	46	24	108	—	—	235	255	—	2	8.55
306.5	257	53.5	75	41	116	211	224	265	295	346	3	28.5
365	280	43	117	59	122	—	—	290	335	—	4	69

**Note** (1) For heavy load applications, a *d*<sub>a</sub> value should be chosen which is large enough to support the shaft washer rib.



Bore Diameter 220~420 mm

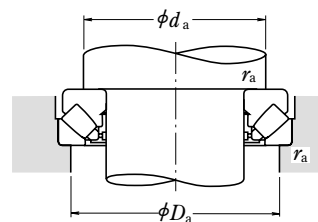
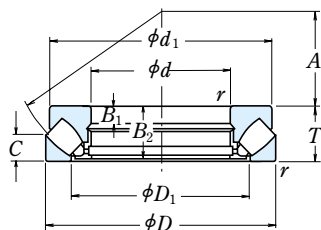

**Dynamic Equivalent Load**

$$P = 1.2F_r + F_a$$

**Static Equivalent Load**

$$P_0 = 2.8F_r + F_a$$

However,  $F_r/F_a \leq 0.55$  must be satisfied.

Boundary Dimensions (mm)				Basic Load Ratings (N) / (kgf)				Limiting Speeds (rpm) oil	Bearing Numbers
d	D	T	r min	C <sub>a</sub>	C <sub>0a</sub>	C <sub>a</sub>	C <sub>0a</sub>		
<b>220</b>	300	48	2	560 000	2 500 000	57 000	255 000	1 400	<b>29244</b>
	360	85	4	1 340 000	5 200 000	137 000	530 000	950	<b>29344</b>
	420	122	6	2 350 000	8 650 000	240 000	880 000	800	<b>29444</b>
<b>240</b>	340	60	2.1	800 000	3 450 000	82 000	350 000	1 200	<b>29248</b>
	380	85	4	1 360 000	5 400 000	139 000	550 000	950	<b>29348</b>
	440	122	6	2 420 000	9 100 000	247 000	930 000	750	<b>29448</b>
<b>260</b>	360	60	2.1	855 000	3 850 000	87 500	395 000	1 200	<b>29252</b>
	420	95	5	1 700 000	6 800 000	173 000	695 000	800	<b>29352</b>
	480	132	6	2 820 000	10 700 000	287 000	1 090 000	710	<b>29452</b>
<b>280</b>	380	60	2.1	885 000	4 100 000	90 000	420 000	1 100	<b>29256</b>
	440	95	5	1 830 000	7 650 000	187 000	780 000	800	<b>29356</b>
	520	145	6	3 400 000	13 100 000	345 000	1 330 000	630	<b>29456</b>
<b>300</b>	420	73	3	1 160 000	5 150 000	118 000	525 000	950	<b>29260</b>
	480	109	5	2 190 000	9 100 000	224 000	925 000	710	<b>29360</b>
	540	145	6	3 500 000	13 700 000	355 000	1 390 000	630	<b>29460</b>
<b>320</b>	440	73	3	1 190 000	5 450 000	122 000	555 000	950	<b>29264</b>
	500	109	5	2 230 000	9 400 000	227 000	960 000	670	<b>29364</b>
	580	155	7.5	3 650 000	14 600 000	370 000	1 490 000	560	<b>29464</b>
<b>340</b>	460	73	3	1 230 000	5 750 000	125 000	590 000	900	<b>29268</b>
	540	122	5	2 640 000	11 200 000	269 000	1 140 000	630	<b>29368</b>
	620	170	7.5	4 400 000	17 400 000	450 000	1 780 000	530	<b>29468</b>
<b>360</b>	500	85	4	1 550 000	7 300 000	158 000	745 000	800	<b>29272</b>
	560	122	5	2 670 000	11 500 000	272 000	1 180 000	600	<b>29372</b>
	640	170	7.5	4 200 000	17 200 000	430 000	1 750 000	500	<b>29472</b>
<b>380</b>	520	85	4	1 620 000	7 800 000	165 000	795 000	800	<b>29276</b>
	600	132	6	3 300 000	14 500 000	335 000	1 480 000	560	<b>29376</b>
	670	175	7.5	4 800 000	19 500 000	490 000	1 990 000	480	<b>29476</b>
<b>400</b>	540	85	4	1 640 000	8 000 000	167 000	815 000	750	<b>29280</b>
	620	132	6	3 250 000	14 500 000	330 000	1 480 000	530	<b>29380</b>
	710	185	7.5	5 400 000	22 100 000	550 000	2 250 000	450	<b>29480</b>
<b>420</b>	580	95	5	2 010 000	9 800 000	205 000	1 000 000	670	<b>29284</b>
	650	140	6	3 500 000	15 700 000	355 000	1 600 000	500	<b>29384</b>
	730	185	7.5	5 650 000	23 500 000	575 000	2 400 000	450	<b>29484</b>

Dimensions (mm)						Abutment and Fillet Dimensions (mm)			Mass (kg) approx
d <sub>1</sub>	D <sub>1</sub>	B <sub>1</sub>	B <sub>2</sub>	C	A	d <sub>a</sub> <sup>(1)</sup> min	D <sub>a</sub> max	r <sub>a</sub> max	
285	254	15	46	24	117	260	275	2	9.2
335	280	29	81	41	125	285	315	3	33
385	308	43	117	58	132	310	355	5	74
325	283	19	57	30	130	285	305	2	16.5
355	300	29	81	41	135	300	330	3	35.5
405	326	43	117	59	142	330	375	5	79
345	302	19	57	30	139	305	325	2	18
390	329	32	91	45	148	330	365	4	48.5
445	357	48	127	64	154	360	405	5	105
365	323	19	57	30	150	325	345	2	19
410	348	32	91	46	158	350	390	4	52.5
480	384	52	140	68	166	390	440	5	132
400	353	21	69	38	162	355	380	2.5	30
450	379	37	105	50	168	380	420	4	74
500	402	52	140	70	175	410	460	5	140
420	372	21	69	38	172	375	400	2.5	32.5
470	399	37	105	53	180	400	440	4	77
555	436	55	149	75	191	435	495	6	175
440	395	21	69	37	183	395	420	2.5	33.5
510	428	41	117	59	192	430	470	4	103
590	462	61	164	82	201	465	530	6	218
480	423	25	81	44	194	420	455	3	51
525	448	41	117	59	202	450	495	4	107
610	480	61	164	82	210	485	550	6	228
496	441	27	81	42	202	440	475	3	52
568	477	44	127	63	216	480	525	5	140
640	504	63	168	85	230	510	575	6	254
517	460	27	81	42	212	460	490	3	55
590	494	44	127	64	225	500	550	5	150
680	536	67	178	89	236	540	610	6	306
553	489	30	91	46	225	490	525	4	72
620	520	48	135	68	235	525	575	5	170
700	556	67	178	89	244	560	630	6	323

**Note** (1) For heavy load applications, a  $d_a$  value should be chosen which is large enough to support the shaft washer rib.

Bore Diameter 440~500 mm

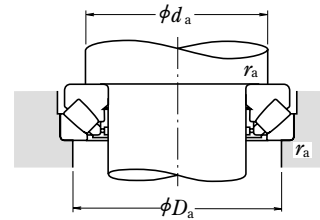
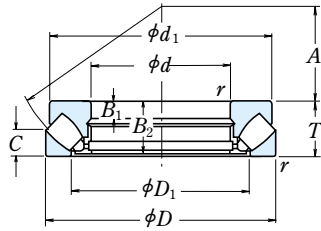

**Dynamic Equivalent Load**  
 $P = 1.2F_r + F_a$   
**Static Equivalent Load**  
 $P_0 = 2.8F_r + F_a$   
 However,  $F_r/F_a \leq 0.55$  must be satisfied.

d	Boundary Dimensions (mm)			Basic Load Ratings				Limiting Speeds (rpm) oil	Bearing Numbers
	D	T	r min	(N)		(kgf)			
				Ca	C0a	Ca	C0a		
440	600	95	5	2 030 000	10 100 000	207 000	1 030 000	670	<b>29288</b>
	680	145	6	3 750 000	16 700 000	380 000	1 710 000	480	<b>29388</b>
	780	206	9.5	6 550 000	27 200 000	665 000	2 770 000	400	<b>29488</b>
460	620	95	5	2 060 000	10 300 000	210 000	1 050 000	670	<b>29292</b>
	710	150	6	4 100 000	18 400 000	420 000	1 880 000	450	<b>29392</b>
	800	206	9.5	6 750 000	28 600 000	690 000	2 920 000	380	<b>29492</b>
480	650	103	5	2 370 000	12 100 000	241 000	1 240 000	600	<b>29296</b>
	730	150	6	4 150 000	19 000 000	425 000	1 940 000	450	<b>29396</b>
	850	224	9.5	7 200 000	31 000 000	730 000	3 150 000	360	<b>29496</b>
500	670	103	5	2 390 000	12 400 000	244 000	1 270 000	600	<b>292/500</b>
	750	150	6	4 350 000	20 400 000	445 000	2 080 000	450	<b>293/500</b>
	870	224	9.5	7 850 000	33 000 000	800 000	3 350 000	340	<b>294/500</b>

Dimensions (mm)						Abutment and Fillet Dimensions (mm)			Mass (kg) approx
d1	D1	B1	B2	C	A	da(1) min	Da max	ra max	
575	508	30	91	49	235	510	545	4	77
645	548	49	140	70	245	550	600	5	190
745	588	74	199	100	260	595	670	8	407
592	530	30	91	46	245	530	570	4	80
666	567	51	144	72	257	575	630	5	210
765	608	74	199	100	272	615	690	8	420
624	556	33	99	55	259	555	595	4	97
690	590	51	144	72	270	595	650	5	215
810	638	81	216	108	280	645	730	8	545
645	574	33	99	55	268	575	615	4	100
715	611	51	144	74	280	615	670	5	220
830	661	81	216	107	290	670	750	8	560

**Note** (1) For heavy load applications, a da value should be chosen which is large enough to support the shaft washer rib.

## ANGULAR CONTACT THRUST BALL BEARINGS

**DOUBLE-DIRECTION ANGULAR  
CONTACT THRUST BALL BEARINGS**  
**ANGULAR CONTACT THRUST  
BALL BEARINGS FOR BALL SCREWS**

Bore Diameter 35~400mm .....Pages B234~B237

Bore Diameter 15~ 60mm .....Pages B238~B239

### DESIGN, TYPE, AND FEATURES

#### DOUBLE-DIRECTION ANGULAR CONTACT THRUST BALL BEARINGS

Double-Direction Angular Contact Thrust Ball Bearings are specially designed high precision bearings for the main spindles of machine tools.

Compared with the Thrust Ball Bearings in the 511 Series, this type contains more balls of smaller diameter and has a contact angle of 60°. Consequently, the influence of centrifugal force is less and they can withstand higher speed and have higher rigidity.

Bearings in Series 20 and 29 have the same inner and outer diameters as the double-row cylindrical roller bearings in Series NN30 and NN49 respectively, and they are both used for high axial loads.

Their cages are machined brass.

There are the BTR, BAR Series of highly rigid angular contact ball bearings suitable for high speed that can be easily replaced by these double- direction angular contact ball bearings. For more details, please contact NSK.

#### ANGULAR CONTACT THRUST BALL BEARINGS FOR BALL SCREWS

Bearings of this type were specially designed to support NSK Precision Ball Screws. They are usually used in combinations of more than two bearings and with a preload. Their contact angle is 60°. For more details, please refer to Catalog **CAT. No. E1254 SUPER PRECISION BEARINGS**.

Their cages are molded polyamide.

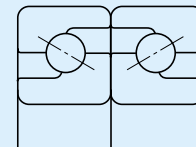
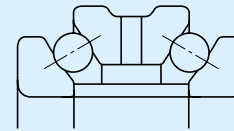

**TOLERANCES AND RUNNING ACCURACY**

**DOUBLE-DIRECTION ANGULAR CONTACT THRUST BALL BEARINGS** .....Table 1

**ANGULAR CONTACT THRUST BALL BEARINGS FOR BALL SCREWS** .....Table 2

The limiting chamfer dimensions of bearings of both types conform to Table 8.9.1 (Page A78).

**Table 1 Tolerances for Double-Direction Angular Contact Thrust Ball Bearings (Class 7 <sup>(1)</sup>)**

**Table 1.1 Tolerances for Bearing Bore and Height and Running Accuracy** Units :  $\mu\text{m}$

Nominal Bore Diameter $d$ (mm)		$\Delta d_{mp}$		$\Delta T_s$		$K_{ia}$ (or $K_{ea}$ )	$S_d$	$S_{ia}$ (or $S_{ea}$ )
over	incl	high	low	high	low	max	max	max
—	30	0	-5	0	-300	5	4	3
30	50	0	-5	0	-400	5	4	3
50	80	0	-8	0	-500	6	5	5
80	120	0	-8	0	-600	6	5	5
120	180	0	-10	0	-700	8	8	5
180	250	0	-13	0	-800	8	8	6
250	315	0	-15	0	-900	10	10	6
315	400	0	-18	0	-1200	10	12	7

**Note** <sup>(1)</sup> Class 7 is NSK Standard.

**Table 1.2 Tolerances for Housing Washer Outside Diameter** Units :  $\mu\text{m}$

Nominal Outside Diameter $D$ (mm)		$\Delta D_s$	
over	incl	high	low
30	50	-25	-41
50	80	-30	-49
80	120	-36	-58
120	180	-43	-68
180	250	-50	-79
250	315	-56	-88
315	400	-62	-98
400	500	-68	-108
500	630	-76	-120

Symbols in the tables are described on Page A59.

**Table 2 Tolerances and Running Accuracy of Angular Contact Thrust Ball Bearings for Ball Screws (Class 7A <sup>(1)</sup>)**

**Table 2.1 Tolerances and Limits for Shaft and Housing Washer** Units :  $\mu\text{m}$

Nominal Bore Diameter $d$ (mm)		$\Delta d_{mp}$		$\Delta B_s$ (or $\Delta C_s$ )		$V_{B_s}$ (or $V_{C_s}$ )	$K_{ia}$	$S_d$	$S_{ia}$
over	incl	high	low	high	low	max	max	max	max
10	18	0	-4	0	-120	1.5	2.5	4	2.5
18	30	0	-5	0	-120	1.5	3	4	2.5
30	50	0	-6	0	-120	1.5	4	4	2.5
50	80	0	-7	0	-150	1.5	4	5	2.5

**Note** <sup>(1)</sup> Class 7A is NSK Standard.

**RECOMMENDED FITS**

**DOUBLE-DIRECTION ANGULAR CONTACT THRUST BALL BEARINGS**

The shaft washer and shaft should be in soft contact with neither interference nor clearance, and the housing washer and housing bore should be loosely fitted. For a bearing arrangement with a double-row cylindrical roller bearing, the tolerances for the outside diameter should be f6 to produce a loose fit.

**ANGULAR CONTACT THRUST BALL BEARINGS FOR BALL SCREWS**

A tolerance of h5 is recommended for shafts and H6 for housing bores.

**INTERNAL CLEARANCE AND PRELOAD**

In order to produce an appropriate preload on bearings when they are mounted, the following axial internal clearances are recommended.

**DOUBLE-ROW ANGULAR CONTACT THRUST BALL BEARINGS** .....Clearance C7

**ANGULAR CONTACT THRUST BALL BEARINGS FOR BALL SCREWS** .....Clearance C10

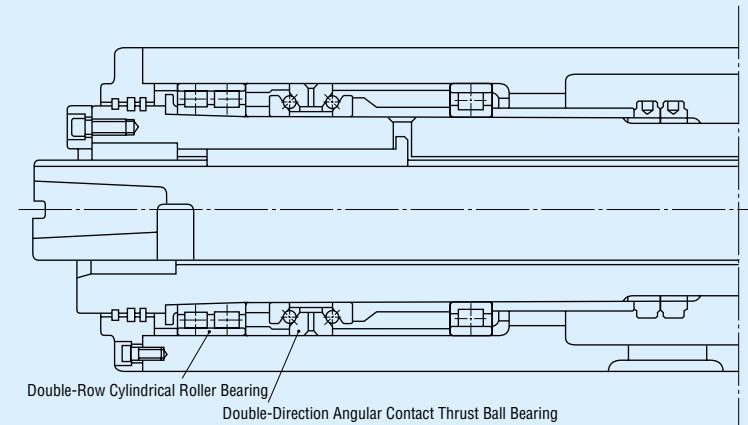

**Example of Application of Double-Direction Angular Contact Thrust Ball Bearing (Main Spindle of Machine Tool)**

**Table 2.2 Tolerances and Running Accuracy of Housing Washer** Units :  $\mu\text{m}$

Nominal Outside Diameter $D$ (mm)		$\Delta D_s$		$K_{ea}$	$S_{ea}$
over	incl	high	low	max	max
30	50	0	-6	5	2.5
50	80	0	-7	5	2.5
80	120	0	-8	5	2.5

Bore Diameter 35~150 mm

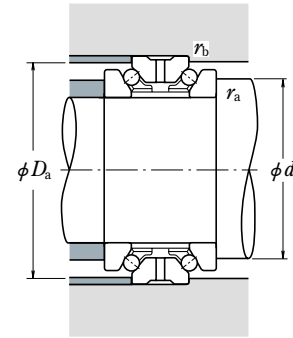
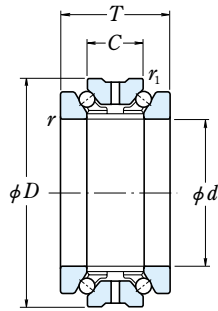

Boundary Dimensions (mm)						Basic Load Ratings (N) (kgf)				Limiting Speeds (rpm)	
d	D <sup>(1)</sup>	T	C	r <sub>min</sub>	r <sub>1 min</sub>	C <sub>a</sub>	C <sub>0a</sub>	C <sub>a</sub>	C <sub>0a</sub>	Grease	Oil
<b>35</b>	62	34	17	1	0.6	22 800	53 500	2 330	5 450	10 000	11 000
<b>40</b>	68	36	18	1	0.6	23 600	59 000	2 410	6 050	9 000	10 000
<b>45</b>	75	38	19	1	0.6	26 300	67 500	2 680	6 900	8 000	9 000
<b>50</b>	80	38	19	1	0.6	27 200	74 000	2 780	7 550	7 000	8 000
<b>55</b>	90	44	22	1.1	0.6	33 500	94 000	3 450	9 550	6 300	6 900
<b>60</b>	95	44	22	1.1	0.6	35 000	102 000	3 550	10 400	5 900	6 500
<b>65</b>	100	44	22	1.1	0.6	36 000	110 000	3 700	11 300	5 500	6 100
<b>70</b>	110	48	24	1.1	0.6	49 500	146 000	5 050	14 900	5 000	5 600
<b>75</b>	115	48	24	1.1	0.6	50 000	152 000	5 100	15 500	4 800	5 300
<b>80</b>	125	54	27	1.1	0.6	59 000	181 000	6 000	18 500	4 400	4 900
<b>85</b>	130	54	27	1.1	0.6	59 500	189 000	6 050	19 300	4 200	4 700
<b>90</b>	140	60	30	1.5	1	78 500	246 000	8 000	25 100	4 000	4 400
<b>95</b>	145	60	30	1.5	1	79 500	256 000	8 100	26 100	3 800	4 200
<b>100</b>	140	48	24	1.1	0.6	55 000	196 000	5 600	20 000	3 800	4 200
	150	60	30	1.5	1	80 500	267 000	8 200	27 200	3 600	4 000
<b>105</b>	145	48	24	1.1	0.6	56 500	208 000	5 750	21 300	3 600	4 000
	160	66	33	2	1	91 500	305 000	9 350	31 000	3 400	3 800
<b>110</b>	150	48	24	1.1	0.6	57 000	215 000	5 800	21 900	3 500	3 900
	170	72	36	2	1	103 000	350 000	10 500	35 500	3 300	3 600
<b>120</b>	165	54	27	1.1	0.6	66 500	256 000	6 800	26 100	3 200	3 600
	180	72	36	2	1	106 000	375 000	10 800	38 000	3 000	3 400
<b>130</b>	180	60	30	1.5	1	79 500	315 000	8 100	32 500	3 000	3 300
	200	84	42	2	1	134 000	455 000	13 600	46 500	2 800	3 100
<b>140</b>	190	60	30	1.5	1	91 500	365 000	9 350	37 500	2 800	3 100
	210	84	42	2	1	145 000	525 000	14 800	53 500	2 600	2 900
<b>150</b>	210	72	36	2	1	116 000	465 000	11 800	47 500	2 500	2 800
	225	90	45	2.1	1.1	172 000	620 000	17 500	63 500	2 400	2 700

Note (1) Outside tolerance is f6.

Bearing Numbers	Abutment and Fillet Dimensions (mm)				Mass (kg) approx
	d <sub>a</sub>	D <sub>a</sub>	r <sub>a max</sub>	r <sub>b max</sub>	
<b>35 TAC 20X+L</b>	46	58	1	0.6	0.375
<b>40 TAC 20X+L</b>	51	63	1	0.6	0.460
<b>45 TAC 20X+L</b>	57	70	1	0.6	0.580
<b>50 TAC 20X+L</b>	62	75	1	0.6	0.625
<b>55 TAC 20X+L</b>	69	84	1	0.6	0.945
<b>60 TAC 20X+L</b>	74	89	1	0.6	1.000
<b>65 TAC 20X+L</b>	79	94	1	0.6	1.080
<b>70 TAC 20X+L</b>	87	104	1	0.6	1.460
<b>75 TAC 20X+L</b>	92	109	1	0.6	1.550
<b>80 TAC 20X+L</b>	99	117	1	0.6	2.110
<b>85 TAC 20X+L</b>	104	122	1	0.6	2.210
<b>90 TAC 20X+L</b>	110	131	1.5	1	2.930
<b>95 TAC 20X+L</b>	115	136	1.5	1	3.050
<b>100 TAC 29X+L</b>	117	134	1	0.6	1.950
<b>100 TAC 20X+L</b>	120	141	1.5	1	3.200
<b>105 TAC 29X+L</b>	122	139	1	0.6	2.040
<b>105 TAC 20X+L</b>	127	150	2	1	4.100
<b>110 TAC 29X+L</b>	127	144	1	0.6	2.120
<b>110 TAC 20X+L</b>	134	158	2	1	5.150
<b>120 TAC 29X+L</b>	139	157	1	0.6	2.940
<b>120 TAC 20X+L</b>	144	168	2	1	5.500
<b>130 TAC 29X+L</b>	150	170	1.5	1	3.950
<b>130 TAC 20X+L</b>	160	187	2	1	8.200
<b>140 TAC 29D+L</b>	158	182	1.5	1	4.200
<b>140 TAC 20D+L</b>	167	198	2	1	8.750
<b>150 TAC 29D+L</b>	172	200	2	1	6.600
<b>150 TAC 20D+L</b>	178	213	2	1	10.700

Remarks Nominal bearing bore and outside diameters for 20X · 20D and 29X · 29D bearing series are the same as those for the NN30 and NNU49 · NN49 bearing series respectively.

Bore Diameter 160~400 mm

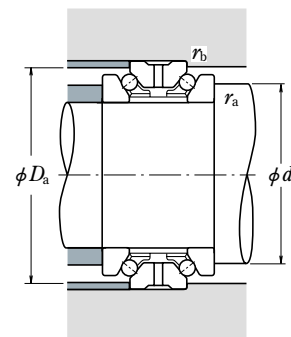
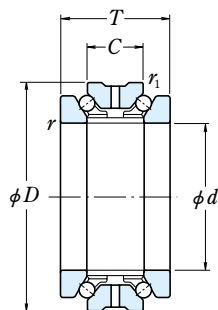

<i>d</i>	Boundary Dimensions (mm)					Basic Load Ratings				Limiting Speeds (rpm)	
	<i>D</i> <sup>(1)</sup>	<i>T</i>	<i>C</i>	<i>r</i> <sub>min</sub>	<i>r</i> <sub>1 min</sub>	(N)		{kgf}		Grease	Oil
						<i>C</i> <sub>a</sub>	<i>C</i> <sub>0a</sub>	<i>C</i> <sub>a</sub>	<i>C</i> <sub>0a</sub>		
<b>160</b>	220	72	36	2	1	118 000	490 000	12 100	50 000	2 400	2 700
	240	96	48	2.1	1.1	185 000	680 000	18 900	69 500	2 300	2 500
<b>170</b>	230	72	36	2	1	120 000	520 000	12 300	53 000	2 300	2 500
	260	108	54	2.1	1.1	218 000	810 000	22 200	82 500	2 100	2 400
<b>180</b>	250	84	42	2	1	158 000	655 000	16 100	67 000	2 100	2 400
	280	120	60	2.1	1.1	281 000	1 020 000	28 700	104 000	2 000	2 200
<b>190</b>	260	84	42	2	1	161 000	695 000	16 400	71 000	2 000	2 300
	290	120	60	2.1	1.1	285 000	1 060 000	29 000	108 000	1 900	2 100
<b>200</b>	280	96	48	2.1	1.1	204 000	855 000	20 800	87 000	1 900	2 100
	310	132	66	2.1	1.1	315 000	1 180 000	32 000	120 000	1 800	2 000
<b>220</b>	300	96	48	2.1	1.1	210 000	930 000	21 400	95 000	1 800	2 000
<b>240</b>	320	96	48	2.1	1.1	213 000	980 000	21 700	100 000	1 700	1 800
<b>260</b>	360	120	60	2.1	1.1	315 000	1 390 000	32 000	141 000	1 500	1 700
<b>280</b>	380	120	60	2.1	1.1	320 000	1 470 000	32 500	150 000	1 400	1 600

Note <sup>(1)</sup> Outside tolerance is f6.

Bearing Numbers	Abutment and Fillet Dimensions (mm)				Mass (kg) approx
	<i>d</i> <sub>a</sub>	<i>D</i> <sub>a</sub>	<i>r</i> <sub>a max</sub>	<i>r</i> <sub>b max</sub>	
<b>160 TAC 29D+L</b> <b>160 TAC 20D+L</b>	182 191	210 228	2 2	1 1	7.000 13.000
<b>170 TAC 29D+L</b> <b>170 TAC 20D+L</b>	192 206	219 245	2 2	1 1	7.350 17.700
<b>180 TAC 29D+L</b> <b>180 TAC 20D+L</b>	207 220	238 264	2 2	1 1	10.700 23.400
<b>190 TAC 29D+L</b> <b>190 TAC 20D+L</b>	217 230	247 274	2 2	1 1	11.200 24.400
<b>200 TAC 29D+L</b> <b>200 TAC 20D+L</b>	230 245	267 291	2 2	1 1	15.700 31.500
<b>220 TAC 29D+L</b>	250	287	2	1	17.000
<b>240 TAC 29D+L</b>	270	307	2	1	18.300
<b>260 TAC 29D+L</b>	300	344	2	1	31.500
<b>280 TAC 29D+L</b>	320	364	2	1	33.500

Remarks Nominal bearing bore and outside diameters for **20X · 20D** and **29X · 29D** bearing series are the same as those for the **NN30** and **NNU49 · NN49** bearing series respectively.



Bore Diameter 17~60 mm

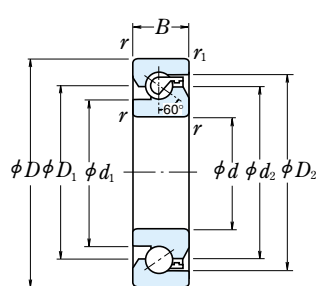

Double-Row Combination

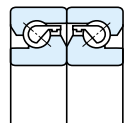

DF

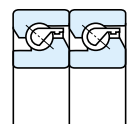

DT

Three-Row Combination

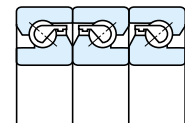

DFD

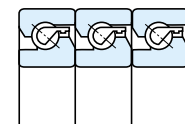

DTD

Four-Row Combination

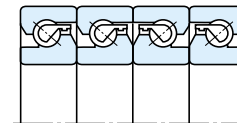

DFF

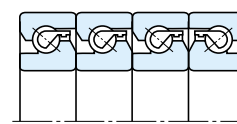

DFT

Dynamic Equivalent Load

$$P_a = XF_r + YF_a$$

Combination	Two Rows		Three Rows		Four Rows				
	DF	DT	DFD	DTD	DFT	DFF	DFT		
Axial Load Sustained by $e=2.17$	One Row	Two Rows	One Row	Two Rows	Three Rows	One Row	Two Rows	Three Rows	
	X	1.9	—	1.43	2.33	—	1.17	2.33	2.53
$F_a/F_r \leq e$	Y	0.55	—	0.77	0.35	—	0.89	0.35	0.26
	X	0.92	0.92	0.92	0.92	0.92	0.92	0.92	0.92
$F_a/F_r > e$	Y	1	1	1	1	1	1	1	1

Boundary Dimensions (mm)					Dimensions (mm)				Limiting Speeds <sup>(1)</sup> (rpm)		Bearing Numbers	Mass (kg) approx
d	D	B	r <sub>min</sub>	r <sub>1 min</sub>	d <sub>1</sub>	d <sub>2</sub>	D <sub>1</sub>	D <sub>2</sub>	Grease	Oil		
15	47	15	1	0.6	27.2	34	34	39.6	6 000	8 000	15 TAC 47B	0.144
17	47	15	1	0.6	27.2	34	34	39.6	6 000	8 000	17 TAC 47B	0.144
20	47	15	1	0.6	27.2	34	34	39.6	6 000	8 000	20 TAC 47B	0.135
25	62	15	1	0.6	37	45	45	50.7	4 500	6 000	25 TAC 62B	0.252
30	62	15	1	0.6	39.5	47	47	53.2	4 300	5 600	30 TAC 62B	0.224
35	72	15	1	0.6	47	55	55	60.7	3 600	5 000	35 TAC 72B	0.31
40	72	15	1	0.6	49	57	57	62.7	3 600	4 800	40 TAC 72B	0.275
	90	20	1	0.6	57	68	68	77.2	3 000	4 000	40 TAC 90B	0.674
45	75	15	1	0.6	54	62	62	67.7	3 200	4 300	45 TAC 75B	0.27
	100	20	1	0.6	64	75	75	84.2	2 600	3 600	45 TAC 100B	0.842
50	100	20	1	0.6	67.5	79	79	87.7	2 600	3 400	50 TAC 100B	0.778
55	100	20	1	0.6	67.5	79	79	87.7	2 600	3 400	55 TAC 100B	0.714
	120	20	1	0.6	82	93	93	102.2	2 200	3 000	55 TAC 120B	1.23
60	120	20	1	0.6	82	93	93	102.2	2 200	3 000	60 TAC 120B	1.16

Note <sup>(1)</sup> These values apply when the standard preload (C10) is used.

Basic Load Ratings C <sub>a</sub>						Limiting Axial Load					
Sustained by one row DF (N) (kgf)		Sustained by two rows DT, DFD, DFF (N) (kgf)		Sustained by three rows DTD, DFT (N) (kgf)		Sustained by one row DF (N) (kgf)		Sustained by two rows DT, DFD, DFF (N) (kgf)		Sustained by three rows DTD, DFT (N) (kgf)	
21 900	2 240	35 500	3 650	47 500	4 850	26 600	2 710	53 000	5 400	79 500	8 150
21 900	2 240	35 500	3 650	47 500	4 850	26 600	2 710	53 000	5 400	79 500	8 150
21 900	2 240	35 500	3 650	47 500	4 850	26 600	2 710	53 000	5 400	79 500	8 150
28 500	2 910	46 500	4 700	61 500	6 250	40 500	4 150	81 500	8 300	122 000	12 500
29 200	2 980	47 500	4 850	63 000	6 400	43 000	4 400	86 000	8 800	129 000	13 200
31 000	3 150	50 500	5 150	67 000	6 850	50 000	5 100	100 000	10 200	150 000	15 300
31 500	3 250	51 500	5 250	68 500	7 000	52 000	5 300	104 000	10 600	157 000	16 000
59 000	6 000	95 500	9 750	127 000	13 000	89 500	9 150	179 000	18 300	269 000	27 400
33 000	3 350	53 500	5 450	71 000	7 250	57 000	5 800	114 000	11 600	170 000	17 400
61 500	6 300	100 000	10 200	133 000	13 600	99 000	10 100	198 000	20 200	298 000	30 500
63 000	6 400	102 000	10 400	136 000	13 800	104 000	10 600	208 000	21 200	310 000	32 000
63 000	6 400	102 000	10 400	136 000	13 800	104 000	10 600	208 000	21 200	310 000	32 000
67 500	6 850	109 000	11 200	145 000	14 800	123 000	12 600	246 000	25 100	370 000	37 500
67 500	6 850	109 000	11 200	145 000	14 800	123 000	12 600	246 000	25 100	370 000	37 500

## NEEDLE ROLLER BEARINGS

### CAGE & NEEDLE ROLLER ASSEMBLIES

Inscribed Circle Diameter 5~100mm... Pages B248~B251

Cage & Needle Roller Assemblies for Connecting Rod

Inscribed Circle Diameter 12~ 30mm... Pages B252~B253

### DRAWN CUP NEEDLE ROLLER BEARINGS

With Cage

Inscribed Circle Diameter 4~ 55mm... Pages B254~B259

Full Complement Type

Inscribed Circle Diameter 8~ 55mm... Pages B254~B259

### SOLID NEEDLE ROLLER BEARINGS

Inscribed Circle Diameter 9~390mm... Pages B260~B269

### THRUST NEEDLE ROLLER BEARINGS

Bore Diameter 10~100mm ..... Pages B270~B271

### CAM FOLLOWERS

Outside Diameter 16~ 90mm ..... Pages B272~B273

### ROLLER FOLLOWERS

Bore Diameter 5~ 50mm ..... Pages B274~B275

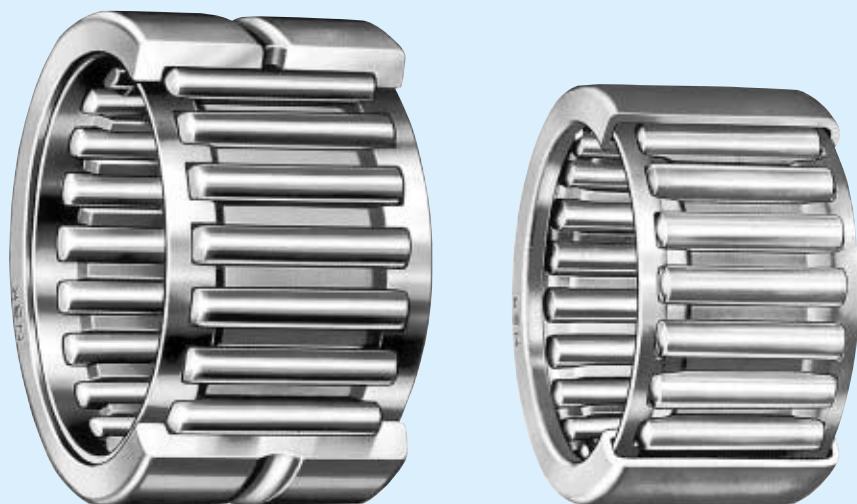

### DESIGN AND TYPES

For needle roller bearings, there are many designs and types bearings. Catalog

Specified catalog, NSK Needle Roller Bearings CAT.No.E1419 lists bearings shown in Table 1. Representative examples selected from them, are shown in this catalog. (shown with ■ in Table 1) For details, please refer individual specified catalog.

For bearing selection, please contact NSK.

**Table1 Types of Needle Roller Bearings**

Cage & Needle Roller Assemblies	<b>FWJ</b> <b>FWF</b> WJ		<b>FBN, FBNP</b> WJC FWJC	
Drawn Cup Needle Roller Bearings	<b>FJ, FJH</b> J, JH		<b>MFJ, MFJH</b> MJ, MJH	
	<b>F, FH</b> B, BH FJT, FJTT MFJT FJLT, FJLTT MFJLT		<b>MF, MFH</b> M, MH	
Solid Needle Roller Bearings	<b>RNA 48</b> <b>RNA 49</b> <b>RNA 59</b> <b>RNA 69</b> HJ		<b>RLM</b>	
			<b>RNAF</b>	
			<b>RNA...TT</b>	
Thrust Needle Roller Bearings	<b>FNTA</b> NTA		<b>FTRA</b> TRA	
Thrust raceway washers	<b>FB</b>		<b>FTRB</b> TRB	
			<b>FTRC</b> TRC	
			<b>FTRD</b> TRD	
			<b>FTRE</b> TRE	
Needle Rollers	<b>A Type</b> (Please refer to B350 page)		<b>F Type</b>	
	<b>T Type</b>		<b>C Type</b>	
Cam Followers	<b>FCR</b> <b>FCJ</b> CR		<b>FCRS</b> <b>FCJS</b> CRS	
			<b>FYCR</b> <b>FYCJ</b> YCR	
			<b>FYCRS</b> <b>FYCJS</b> YCRS	
Needle Roller Bearings For Universal Joints	<b>ZY</b>		<b>NSA</b>	
Drawn Cup Roller Clutches	<b>RC</b>		<b>FC</b>	
			<b>RCB</b>	
			<b>FCB</b>	

Table 2 is applicable to standard drawn cup needle roller bearings (metric series), and Table 3 shows tolerance of roller inscribed circle diameter based on ISO Standards. For bearings assured by ISO Standards, please order by adding symbol of "-1" at the end of bearing number.

**Table 2 Inspection Gauge Dimensions (General Metric) of Drawn Cup Needle Roller Bearings.**  
(FJ, FJH, MFJ, MFJH)  
(F, FH, MF, MFH)

Nominal Roller Inscribed Circle Diameter, $F_w$	Bore Diameter of Ring Gauge	Units mm	
		Plug Gauge	
		GO Gauge	NO-GO Gauge
4	7.996	4.023	4.048
5	8.996	5.023	5.048
6	9.996	6.028	6.053
7	10.995	7.031	7.056
8	11.995	8.031	8.056
9	12.995	9.031	9.056
10	13.995	10.031	10.056
12	15.995	12.031	12.056
FH 12	17.995	12.031	12.056
13	18.993	13.034	13.059
14	19.993	14.034	14.059
15	20.993	15.034	15.059
16	21.993	16.034	16.059
17	22.972	17.013	17.038
18	23.972	18.013	18.038
20	25.972	20.013	20.038
22	27.972	22.013	22.038
25	31.967	25.013	25.038
28	34.967	28.013	28.038
30	36.967	30.013	30.038
35	41.967	35.013	35.043
40	46.967	40.013	40.043
45	51.961	45.013	45.043
50	57.961	50.013	50.043
55	62.961	55.013	55.043

**Table 3 Ring Gauge of Drawn Cup Needle Roller Bearings and Tolerance of Roller Inscribed Circle Diameter (ISO Standards)**  
(FJ, FJH, MFJ and MFJH)  
(F, FH, MF and MFH)

Nominal Roller Inscribed Circle Diameter, $F_w$	Bore Diameter of Ring Gauge	Units mm	
		Tolerance for Roller Inscribed Circle Diameter, $F_{wmin}$ (1)	
		min	max
4	7.984	4.010	4.028
5	8.984	5.010	5.028
6	9.984	6.010	6.028
7	10.980	7.013	7.031
8	11.980	8.013	8.031
H 8	13.980	8.013	8.031
9	12.980	9.013	9.031
H 9	14.980	9.013	9.031
10	13.980	10.013	10.031
H 10	15.980	10.013	10.031
12	15.980	12.016	12.034
H 12	17.980	12.016	12.034
13	18.976	13.016	13.034
14	19.976	14.016	14.034
15	20.976	15.016	15.034
16	21.976	16.016	16.034
17	22.976	17.016	17.034
18	23.976	18.016	18.034
20	25.976	20.020	20.041
22	27.976	22.020	22.041
25	31.972	25.020	25.041
28	34.972	28.020	28.041
30	36.972	30.020	30.041
35	41.972	35.025	35.050
40	46.972	40.025	40.050
45	51.967	45.025	45.050
50	57.967	50.025	50.050
55	62.967	55.030	55.060

**Remarks** This is the gauge dimension for inspection of minimum diameter,  $F_{wmin}$ , of roller inscribed circle diameter.

**Note (1)** When using a cylinder instead of an inner ring,  $F_{wmin}$  is the diameter of the cylinder at which the internal clearance is zero in at least one radial direction. ( $F_{wmin}$  is the minimum diameter of each inscribed circle diameter where deviation is assumed.)

**Remarks** To measure the roller inscribed circle diameter, use the following plug gauges:  
GO gauge: The same dimensions as the minimum tolerance of the roller inscribed circle diameter  $F_{wmin}$ .  
NO-GO gauge: The dimensions should be the maximum tolerance of roller inscribed circle diameter,  $F_{wmin}$ , plus 0.002mm.

**DIMENSIONAL ACCURACY · RUNNING ACCURACY**

**DRAWN CUP NEEDLE ROLLER BEARINGS**

The correct form and dimensional accuracy of outer ring of drawn cup needle roller bearing is achieved only by press fitting into proper housing with appropriate interference. Therefore, roller inscribed circle diameter is measured after press fitted into a standard ring gauge.

The dimension of ring gauge and tolerance of roller inscribed circle diameter are shown in Tables 2 and 3.

**SOLID NEEDLE ROLLER BEARINGS** ..... Table 8. 2 (A60-63 pages)

Tolerance of roller inscribed circle diameter for solid needle roller bearings without inner rings are shown in Table 4.

**Table 4 Inscribed Circle Diameter for Metric Solid Needle Roller Bearings** Units  $\mu\text{m}$

Nominal Inscribed Circle Diameter, $F_w$ (mm)		Deviation (F6) of Minimum Diameter, $F_{w\min}$ , of Roller Inscribed Circle Diameter $F_{w\min}^{(1)}$ $\Delta F_{w\min}$	
over	incl	high	low
6	10	+ 22	+13
10	18	+ 27	+16
18	30	+ 33	+20
30	50	+ 41	+25
50	80	+ 49	+30
80	120	+ 58	+36
120	180	+ 68	+43
180	250	+ 79	+50
250	315	+ 88	+56
315	400	+ 98	+62
400	500	+108	+68

**Note** (1) When using a cylinder instead of an inner ring,  $F_{w\min}$  is the diameter of the cylinder at which the internal clearance is zero in at least one radial direction. ( $F_{w\min}$  is the minimum diameter of each inscribed circle diameter where deviation is assumed.)

**CAM FOLLOWERS · ROLLER FOLLOWERS** ..... Table 8. 2 (A60-63 pages)

The tolerance zone class of stud diameter  $d$  of cam followers is h7, and the tolerance of assembled width of inner ring of roller followers is shown in bearing table.

These tolerances are applied to the bearings before surface treatment.

Cam Follower Dimensional Tolerances is always applied to the bearing before surface treatment.

**RECOMMENDED FITTING AND BEARING INTERNAL CLEARANCE CAGE & NEEDLE ROLLER ASSEMBLIES**

Recommended fitting of cage & roller under typical operating condition is shown in Table 5. By combining cage & roller, shaft, and housing, appropriate radial internal clearance is obtained. However, the fitting and the radial internal clearance of cage & roller for connecting rod should be determined by the type of engine, characteristic, and driving condition etc.. For details, please refer to specified catalog.

**Table 5 Fitting Tolerances for Shafts and Housing Bores**

Operating Conditions	Fitting Tolerance		housing bore
	shaft		
	$F_w \leq 50\text{mm}$	$F_w > 50\text{mm}$	
High Accuracy, Oscillating Motion	js5 (j5)	h5	G6
Normal	h5	g5	
High Temperature, Large Shaft Deflection and Mounting Error of Bearings	f6		

**DRAWN CUP NEEDLE ROLLER BEARINGS**

For FJ, FJH, and MFJH types and F, FH, and MFH types, if tolerance of fitting such as shaft:h6, and housing bore:N7 (in case of thick steel housing), are applied under general operating condition, appropriate radial internal clearance is obtained. In case that outer ring rotation, the fitting of shaft : f6, housing bore : R7, and light alloy housing or steel housing of less than 6mm thickness, the housing bore should be smaller than N7 by 0.013 – 0.025mm.

**SOLID NEEDLE ROLLER BEARINGS**

Recommended fitting for solid needle roller bearings with inner rings

Table 9. 2 (Page A84)

Table 9. 4 (Page A85)

Internal clearance of solid needle roller bearings with inner rings

Table 9. 14 (Page A91)

However, for needle roller bearing of wider bearing width, and with long needle rollers, bearings with CN clearance are not necessarily common, but large clearance is selected frequently. For the solid needle roller bearing without inner ring, it is possible to select radial internal clearance shown in Table 6 by selecting tolerance class of shaft, which is fitting to the bearing.

**Table 6 Fitting Tolerances and Radial Internal clearance of Shafts Assembled with Solid Needle Roller Bearings without Inner Rings**

Nominal Roller Inscribed Circle Diameter $F_w$ (mm)		C2	CN	C3	C4
over	incl				
6	180	k5	g5	f6	e6
180	315	j6	f6	e6	d6
315	490	h6	e6	d6	c6

**THRUST NEEDLE ROLLER BEARINGS**

Recommended Fitting of Thrust Needle Roller Bearings and Thrust Raceway are shown in Table 7.

**Table 7 Recommended Fitting of Thrust Needle Roller Bearings and Thrust Raceway**

Classification	Type	Cage or raceway guide	Tolerance class or dimension tolerance	
			Shaft	Housing bore
			Units mm	
Thrust Needle Bearing Cage & Needle Roller Assemblies	FNTA	Bore	h8	$D_c$ (1)+over 1.0
		Outside	—	H10
Thrust Bearing Rings	FTRA~FTRE	Bore	h8	$D_c$ (1)+over 1.0
		Outside	—	H10

**Note** (1)  $D_c$  represents outside diameter of the cage.

**Remarks** If the cage is guided by outside diameter, to prevent the wear of housing bore, it is necessary to harden the surface at least.

### CAM FOLLOWERS - ROLLER FOLLOWERS

The recommended fittings for the mounting area of cam follower studs are shown in Table 8. Recommended shaft fittings of roller follower are shown in Table 9.

Since cam followers are used with cantilevered mounting, they should be fixed with little clearance of the fitting surface as much as possible.

Since a roller follower is generally used with outer ring rotation, the fitting with shaft is transition or loose fit. In case that heavy loads impose to the roller follower, it is recommended to use the shaft of quench hardening treatment, and with tight fit.

For the details, please refer to specified catalog.

**Table 8 Recommended Fitting for Stud Mounting Part of Cam Followers**

Type	Fitting Tolerance of Mounting Hole
FCR, FCRS	JS7 (J7)
FCJ, FCJS	

**Table 9 Recommended Shaft Fittings of Roller Followers**

Load	Fitting Tolerance of Shaft
Light Load/Normal Load	g6 or h6
Heavy Load	k6

### SHAFT AND HOUSING SPECIFICATIONS

The specification of shaft and housing for radial needle roller bearings, which are used under general operating condition, is shown in Table 10.

**Table 10 Shaft and housing Specifications of Radial Needle Roller Bearings (Cage & Needle Roller Assemblies/Drawn Cup Bearings/Solid Bearings)**

Category	Shaft		Housing Bore	
	Raceway Surface	Fitting Surface	Raceway Surface	Fitting Surface
Out-of-Roundness Tolerance	$\frac{IT3}{2}$	$\frac{IT3}{2} \sim \frac{IT4}{2}$	$\frac{IT3}{2}$	$\frac{IT4}{2} \sim \frac{IT5}{2}$
Cylindricity Tolerance	$\frac{IT3}{2}$	$\frac{IT3}{2} \sim \frac{IT4}{2}$	$\frac{IT3}{2}$	$\frac{IT4}{2} \sim \frac{IT5}{2}$
Roughness $R_a$ ( $\mu\text{m}$ )	0.4	0.8	0.8	1.6
Hardness	HRC58 to 64 Appropriate depth of hardening layer required	—	HRC58 to 64 Appropriate depth of hardening layer required	—

- Remarks**
1. For the specification of shaft and housing of cage & needle roller assembly for connecting rod, please refer to specified catalog.
  2. These are general recommendation by radius method. For the value of standard tolerance (IT), please refer to Appendix 11 (page C22)

Specifications of Thrust Bearings Raceway Surface are shown in Table 11.

**Table 11 Specifications of Thrust Bearings Raceway Surface**

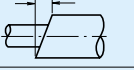
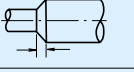
Squareness A	0.5/1000 incl (mm/mm)	
Squareness B	1.0/1000 incl (mm/mm)	
Roughness $R_a$	0.4 ( $\mu\text{m}$ )	—
Hardness	HRC58 to 64 (HRC60 to 64 is favorable)	—

### LIMITING INCLINATION ANGLES

The limiting inclination angle of radial needle roller bearing under general load condition is 0.001 radian (3.4') approximately. For the detail, please refer to specified catalog.

### PERMISSIBLE TRACK LOAD

The permissible load of the track is determined by compression strength or hardness. The permissible load of the track shown in the bearing table is value of a track made of steel with a hardness of HRC40. Table 12 indicates the permissible load coefficient of the track for each hardness.

The permissible load of the track for each hardness can be obtained by multiplying the permissible load coefficient of the track corresponding to each hardness.

### PRE-PACKED GREASE

The cam follower/roller follower with a seal is pre-lubricated with lithium soap-based grease. The range of operating temperature is  $-10$  to  $+110^\circ\text{C}$ . For the cam follower/roller follower without seal, please lubricate with suitable lubricant.

### MAXIMUM PERMISSIBLE LOAD AND MAXIMUM CLAMP TORQUE OF CAM FOLLOWERS.

The maximum radial Load that the cam follower can carry is determined by the bearing strength and shear strength of the stud rather than the Load rating for neele bearings. This value is given in the bearing table as the maximum permissible Load.

Since the stud of the cam follower receives bending stress and tensile stress from the bearing Load, the screw clamp torque should not exceed the value shown in the bearing table.

### LIMITING SPEED

The limiting speeds of bearings are shown in bearing tables. However, depending on load condition of the bearing, the limiting speeds are necessary to compensate. Also, improvement of lubrication method allows to take higher limiting speed. For the detail, please refer to A37 page.

FWF · FWJ

Inscribed Circle Diameter 5~22 mm

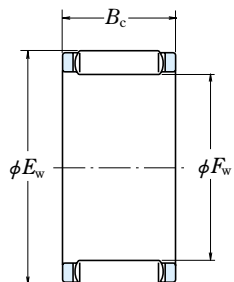

Boundary Dimensions (mm)			Basic Load Ratings				Limiting Speeds	
F <sub>w</sub>	E <sub>w</sub>	B <sub>c</sub> <sup>-0.2</sup> <sub>-0.55</sub>	(N)		{kgf}		Grease	Oil
			C <sub>r</sub>	C <sub>0r</sub>	C <sub>r</sub>	C <sub>0r</sub>		
5	8	8	2 330	1 860	237	189	60 000	95 000
6	9	8	2 200	1 780	224	182	48 000	75 000
	9	10	3 350	3 050	340	310	48 000	75 000
7	10	8	2 840	2 560	290	261	40 000	67 000
	10	10	3 650	3 550	375	360	40 000	67 000
8	11	10	3 950	4 000	400	410	34 000	56 000
	11	13	4 750	5 150	485	525	34 000	56 000
9	12	10	3 750	3 850	380	395	30 000	50 000
	12	13	5 100	5 750	520	585	30 000	50 000
10	13	10	3 950	4 300	405	435	28 000	45 000
	13	13	5 400	6 350	550	650	28 000	45 000
	14	13	6 500	6 750	660	690	28 000	45 000
12	15	10	4 350	5 100	445	520	22 000	36 000
	15	13	5 950	7 600	605	775	22 000	36 000
	16	13	7 350	8 350	750	850	22 000	38 000
14	18	10	6 750	7 750	690	790	19 000	32 000
	18	13	8 050	9 750	820	995	19 000	32 000
	20	17	13 400	14 600	1 370	1 490	20 000	32 000
15	19	10	7 050	8 400	720	855	18 000	28 000
	19	13	8 400	10 500	860	1 070	18 000	28 000
	21	17	13 400	14 800	1 370	1 510	19 000	30 000
16	20	10	7 350	9 000	750	920	17 000	26 000
	20	13	8 800	11 300	895	1 150	17 000	26 000
	22	17	14 700	16 900	1 500	1 720	17 000	28 000
17	21	10	7 650	9 650	780	985	16 000	26 000
	21	13	10 200	14 000	1 040	1 420	16 000	26 000
	23	17	15 100	17 800	1 540	1 810	16 000	26 000
18	22	10	7 900	10 300	805	1 050	15 000	24 000
	22	13	9 450	12 900	965	1 310	15 000	24 000
	24	17	17 400	21 600	1 770	2 210	15 000	24 000
20	24	10	8 000	10 700	815	1 090	13 000	20 000
	24	13	9 700	13 700	990	1 400	13 000	20 000
	26	17	18 000	23 200	1 830	2 370	14 000	22 000
22	26	10	8 600	12 200	880	1 240	12 000	19 000
	26	13	10 300	15 300	1 050	1 560	12 000	19 000
	28	17	17 300	22 700	1 760	2 310	12 000	20 000

Bearing Numbers	Mass (g)
	approx
* FBNP-588	1.0
* FBNP-698	1.2
* FBNP-6910	1.5
* FBNP-7108	1.3
* FBNP-71010	1.6
* FBNP-81110	1.8
* FBNP-81113	2.6
* FBNP-91210	2.0
* FBNP-91213	2.6
FBN-101310	2.2
FBN-101313	2.9
FWF-101413	4.0
FBN-121510	2.6
FBN-121513	3.4
FWF-121613	4.6
FWF-141810	4.1
FWF-141813	5.3
FWF-142017	11
FWF-151910	4.3
FWF-151913	5.6
FWF-152117	12
FWF-162010	4.6
FWF-162013	6.0
FWF-162217	12
FWF-172110	4.8
FWJ-172113	6.3
FWF-172317	14
FWF-182210	5.1
FWF-182213	6.6
FWJ-182417	14
FWF-202410	5.6
FWF-202413	7.3
FWJ-202617	15
FWF-222610	6.1
FWF-222613	7.9
FWF-222817	16

Note (\*) These bearings have polyamide cages. The maximum permissible operating temperature for these bearings is 100 °C for continued operation and 120 °C for short periods.



FWF · FWJ

Inscribed Circle Diameter 25~100 mm

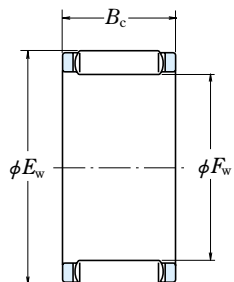

Boundary Dimensions (mm)			Basic Load Ratings				Limiting Speeds	
F <sub>W</sub>	E <sub>W</sub>	B <sub>C</sub> <sup>-0.2 -0.55</sup>	(N)		{kgf}		(rpm)	
			C <sub>r</sub>	C <sub>0r</sub>	C <sub>r</sub>	C <sub>0r</sub>	Grease	Oil
<b>25</b>	29	10	9 350	14 100	950	1 440	10 000	17 000
	29	13	11 300	18 000	1 150	1 830	10 000	17 000
	31	17	19 200	26 800	1 950	2 740	10 000	17 000
<b>28</b>	33	13	13 700	20 400	1 400	2 080	9 500	15 000
	33	17	17 600	28 300	1 800	2 890	9 500	15 000
	34	17	19 900	29 100	2 020	2 970	9 500	15 000
<b>30</b>	35	13	14 000	21 600	1 430	2 200	8 500	14 000
	35	17	18 700	31 500	1 910	3 200	8 500	14 000
	37	20	26 000	38 000	2 650	3 850	9 000	14 000
<b>32</b>	37	13	15 100	24 400	1 540	2 480	8 000	13 000
	37	17	18 500	31 500	1 880	3 200	8 000	13 000
	39	20	27 300	41 000	2 780	4 200	8 500	13 000
<b>35</b>	40	13	14 900	24 600	1 520	2 500	7 500	12 000
	40	17	20 500	37 000	2 090	3 750	7 500	12 000
	42	20	30 000	47 500	3 050	4 850	7 500	12 000
<b>40</b>	45	17	21 000	40 000	2 150	4 050	6 300	10 000
	45	27	32 000	68 000	3 250	6 900	6 300	10 000
	48	25	40 500	66 500	4 150	6 800	6 700	10 000
<b>45</b>	50	17	21 600	43 000	2 200	4 350	5 600	9 000
	50	27	34 000	77 500	3 500	7 900	5 600	9 000
	53	25	44 000	77 000	4 500	7 850	5 600	9 500
<b>50</b>	55	20	26 900	59 000	2 750	6 050	5 000	8 000
	55	27	35 000	83 000	3 600	8 450	5 000	8 000
	58	25	48 500	90 500	4 950	9 200	5 300	8 500
<b>55</b>	61	20	31 000	64 000	3 150	6 500	4 500	7 500
	61	30	47 000	109 000	4 750	11 100	4 500	7 500
	63	25	50 000	97 500	5 100	9 950	4 800	7 500
<b>60</b>	66	20	33 000	71 500	3 350	7 300	4 300	6 700
	66	30	50 000	122 000	5 100	12 400	4 300	6 700
	68	25	52 000	105 000	5 300	10 700	4 300	6 700
<b>65</b>	73	30	61 000	132 000	6 200	13 400	4 000	6 300
	<b>70</b>	30	63 000	140 000	6 400	14 300	3 600	6 000
<b>75</b>	83	30	65 000	151 000	6 650	15 400	3 400	5 600
	<b>80</b>	30	69 000	166 000	7 050	17 000	3 200	5 000
<b>85</b>	93	30	71 000	176 000	7 250	17 900	3 000	4 800
	<b>90</b>	30	70 000	177 000	7 150	18 000	2 800	4 500
<b>95</b>	103	30	69 500	177 000	7 100	18 100	2 600	4 300
	<b>100</b>	108	75 500	201 000	7 700	20 500	2 400	4 000

Bearing Numbers	Mass
	(g)
	approx
<b>FWF-252910</b>	6.9
<b>FWF-252913</b>	8.9
<b>FWF-253117</b>	18
<b>FWF-283313</b>	13
<b>FWF-283317</b>	16
<b>FWF-283417</b>	20
<b>FWF-303513</b>	14
<b>FWF-303517A</b>	18
<b>FWF-303720</b>	30
<b>FWF-323713</b>	14
<b>FWJ-323717</b>	19
<b>FWF-323920</b>	32
<b>FWF-354013</b>	16
<b>FWF-354017</b>	20
<b>FWJ-354220</b>	34
<b>FWF-404517A</b>	23
<b>FWF-404527</b>	36
<b>FWF-404825</b>	56
<b>FWF-455017</b>	26
<b>FWF-455027</b>	41
<b>FWF-455325</b>	62
<b>FWF-505520</b>	37
<b>FWF-505527</b>	50
<b>FWF-505825</b>	77
<b>FWF-556120</b>	53
<b>FWF-556130</b>	81
<b>FWF-556325</b>	85
<b>FWF-606620</b>	57
<b>FWF-606630</b>	87
<b>FWF-606825</b>	91
<b>FWF-657330</b>	120
<b>FWF-707830</b>	125
<b>FWF-758330</b>	135
<b>FWF-808830</b>	145
<b>FWF-859330</b>	150
<b>FWF-909830</b>	160
<b>FWF-9510330</b>	175
<b>FWF-10010830</b>	185

# CAGE & NEEDLE ROLLER ASSEMBLIES

Cage & Needle Roller Assemblies for Large Ends of Connecting Rods  
Inscribed Circle Diameter 12~30 mm

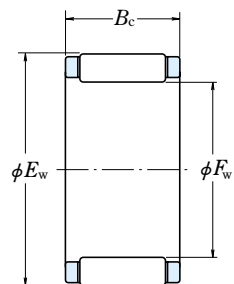

Boundary Dimensions (mm)			Basic Load Ratings (N)				Bearing Numbers	Mass (g) approx
$F_w$	$E_w$	$B_c^{-0.4}$	$C_r$	$C_{0r}$	(kgf)			
<b>12</b>	16	10	6 100	6 500	620	665	<b>FWF-121610-E</b>	4.0
<b>14</b>	19	10	7 800	8 050	795	820	<b>FWF-141910-E</b>	6.2
	20	12	8 900	8 600	910	880	<b>FWF-142012-E</b>	8.3
<b>15</b>	19	9	5 650	6 250	575	640	<b>FWF-15199-E</b>	4.1
	20	10	7 300	7 600	745	775	<b>FWF-152010-E</b>	6.0
	21	10	7 950	7 500	810	765	<b>FWF-152110-E</b>	8.5
<b>16</b>	21	11	8 650	9 600	880	980	<b>FWF-162111-E</b>	7.5
	22	12	9 500	9 600	965	980	<b>FWF-162212-E</b>	9.5
<b>18</b>	23	14	11 800	14 800	1 200	1 510	<b>FWF-182314-E</b>	10
	24	12	10 000	10 600	1 020	1 080	<b>FWF-182412-E</b>	11
<b>20</b>	26	12	12 200	14 100	1 250	1 440	<b>FWF-202612-E</b>	13
	26	17	16 800	21 200	1 710	2 160	<b>FWF-202617-E</b>	17
	28	18	18 100	19 400	1 840	1 970	<b>FWF-202818-E</b>	25
<b>22</b>	28	14	13 900	17 100	1 420	1 740	<b>FWF-222814-E</b>	14
	29	15	16 300	19 000	1 660	1 930	<b>FWF-222915-E</b>	19
	32	16	19 700	19 400	2 010	1 970	<b>FWF-223216-E</b>	31
<b>23</b>	31	16	17 600	19 400	1 800	1 980	<b>FWF-233116-E</b>	23
<b>24</b>	30	15	15 600	20 300	1 590	2 070	<b>FWF-243015-E</b>	17
	30	17	17 900	24 300	1 830	2 480	<b>FWF-243017-E</b>	19
	31	20	21 600	27 800	2 200	2 840	<b>FWF-243120-E</b>	30
<b>25</b>	32	16	17 700	21 900	1 810	2 230	<b>FWF-253216-E</b>	24
<b>28</b>	35	16	18 400	23 700	1 880	2 410	<b>FWF-283516-E</b>	25
<b>29.75</b>	36.75	16.5	19 600	26 000	1 990	2 650	<b>FWF-293616Z-E</b>	28
<b>30</b>	37	16	21 900	30 500	2 230	3 100	<b>FWF-303716-E</b>	29
	38	18	25 500	34 000	2 600	3 450	<b>FWF-303818-E</b>	35

Cage & Needle Roller Assemblies for Small Ends of Connecting Rods  
Inscribed Circle Diameter 9~19 mm

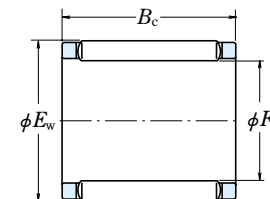

Boundary Dimensions (mm)			Basic Load Ratings (N)				Bearing Numbers	Mass (g) approx
$F_w$	$E_w$	$B_c^{-0.4}$	$C_r$	$C_{0r}$	(kgf)			
<b>9</b>	12	11.5	4 300	4 650	440	475	<b>FBN-91211Z-E</b>	3.5
<b>10</b>	14	12.7	5 900	5 950	605	610	<b>FBN-101412Z-E</b>	5.0
<b>12</b>	15	14.3	6 400	8 400	655	855	<b>FBN-121514Z-E</b>	4.8
	16	13	7 250	8 200	740	835	<b>FBN-121613-E</b>	6.4
	16	15.5	8 500	10 000	865	1 020	<b>FBN-121615Z-E</b>	7.0
	16	16	8 500	10 000	865	1 020	<b>FBN-121616-E</b>	7.5
<b>14</b>	18	12	6 950	8 050	710	820	<b>FBN-141812-E</b>	6.5
	18	16.5	9 250	11 600	945	1 180	<b>FBN-141816Z-E</b>	8.5
	18	18	10 700	14 000	1 090	1 430	<b>FBN-141818-E</b>	11.5
	18	20	9 550	12 000	975	1 230	<b>FBN-141820-E1</b>	13
<b>15</b>	19	18	11 300	15 300	1 150	1 560	<b>FBN-151918-E</b>	11
	21	18	12 900	13 900	1 310	1 420	<b>FBN-152118-E</b>	13
<b>16</b>	20	22	13 700	20 000	1 400	2 040	<b>FBN-162022-E</b>	14
	20	23.5	14 900	22 300	1 520	2 280	<b>FBN-162023Z-E</b>	15
	21	20	14 200	18 100	1 450	1 840	<b>FBN-162120-E</b>	16
<b>17</b>	21	23	14 800	22 500	1 510	2 290	<b>FBN-172123-E</b>	16
<b>18</b>	22	17	11 500	16 500	1 170	1 680	<b>FBN-182217-E</b>	12
	22	22	14 200	21 600	1 440	2 200	<b>FBN-182222-E</b>	15
	22	23.6	15 400	24 100	1 570	2 460	<b>FBN-182223Z-E</b>	16
<b>19</b>	23	23.7	16 000	25 800	1 630	2 630	<b>FBN-192323Z-E</b>	17

FJ • MFJ (With Cage)

F • MF (Full Complement Type)

Inscribed Circle Diameter 4~16 mm

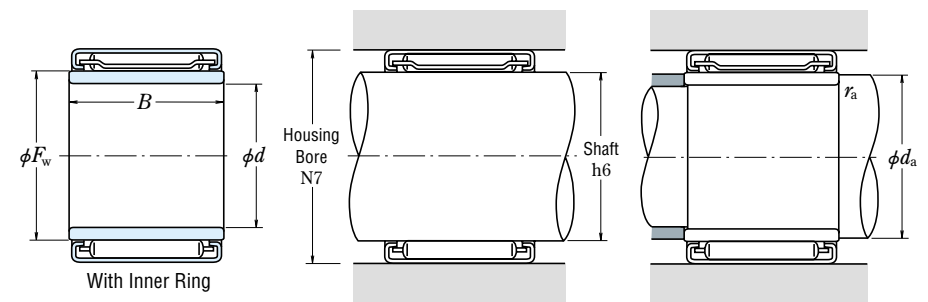
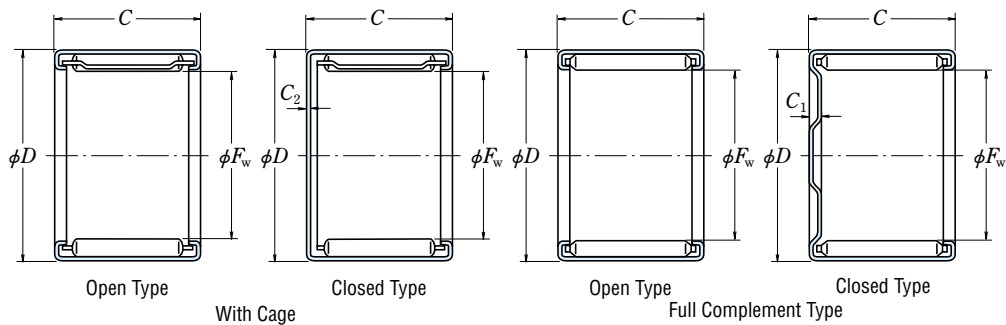

Boundary Dimensions (mm)	Basic Dynamic Load Ratings (N) {kgf}	Limiting Loads (N) {kgf}	Limiting Speeds (rpm)	Bearing							
				With Cage							
$F_w$	$D$	$C^{-0.25}$	$C_1, C_2$	$C_r$	$P_{max}$	Grease	Oil	Open	Closed		
4	8	8	0.8	1 720	175	675	69	45 000	75 000	* FJP-48	—
5	9	9	0.8	1 860	190	745	76	43 000	71 000	FJ-59	MFJ-59
6	10	9	0.8	2 320	237	985	101	36 000	56 000	FJ-69	MFJ-69
7	11	9	0.8	2 550	260	1 110	113	30 000	48 000	FJ-79	MFJ-79
8	12	10	0.8	2 840	289	1 270	130	26 000	43 000	FJ-810	MFJ-810
	14	10	1.0	4 300	435	1 770	180	28 000	45 000	FJH-810	MFJH-810
	14	10	1.9	5 550	565	2 980	305	6 300	10 000	—	—
9	13	10	0.8	3 300	335	1 600	163	22 000	36 000	FJ-910	MFJ-910
	15	10	1.0	4 550	465	1 910	194	24 000	40 000	FJH-910	MFJH-910
	15	10	1.8	6 100	625	3 350	340	6 000	10 000	—	—
10	14	10	0.8	3 500	360	1 760	179	20 000	32 000	FJ-1010	MFJ-1010
	16	10	1.0	4 900	500	2 100	214	22 000	34 000	FJH-1010	MFJH-1010
	16	10	1.9	6 650	680	3 700	375	5 600	9 000	—	—
12	16	10	0.8	4 150	420	2 210	225	17 000	26 000	FJ-1210	MFJ-1210
	18	12	1.0	6 450	655	3 050	310	17 000	28 000	FJH-1212	MFJH-1212
	18	12	1.9	9 000	920	5 700	580	4 500	7 500	—	—
13	19	12	1.0	6 950	710	3 400	345	16 000	26 000	FJ-1312	MFJ-1312
	19	12	1.9	9 550	975	6 100	625	4 300	7 100	—	—
14	20	12	1.0	6 500	665	3 250	335	15 000	24 000	FJ-1412	MFJ-1412
	20	12	2.2	9 450	965	6 350	645	3 800	6 000	—	—
	20	16	1.0	9 500	970	5 300	540	15 000	24 000	FJ-1416	MFJ-1416
	20	16	2.2	13 300	1 360	9 850	1 000	3 800	6 000	—	—
15	21	12	1.0	7 650	780	3 900	400	14 000	22 000	FJ-1512	MFJ-1512
	21	12	1.8	10 300	1 050	6 900	705	3 800	6 000	—	—
	21	14	1.8	12 400	1 270	8 800	895	3 800	6 000	—	—
	21	16	1.0	11 000	1 120	6 200	635	14 000	22 000	FJ-1516	MFJ-1516
	21	16	1.8	14 500	1 480	10 700	1 090	3 800	6 000	—	—
16	22	12	1.0	7 100	725	3 750	380	12 000	20 000	FJ-1612	MFJ-1612
	22	12	2.2	10 200	1 040	7 100	725	3 400	5 300	—	—
	22	16	1.0	10 400	1 060	6 050	620	12 000	20 000	FJ-1616	MFJ-1616
	22	16	2.2	14 400	1 460	11 100	1 130	3 400	5 300	—	—

Note (\*) These bearing have polyamide cages. The maximum permissible operating temperature for these bearings is 100°C for continued operation and 120°C for short periods.

Numbers	In case of inner ring is used				Mass Without Inner Ring (g)	
	Full Complement Type	Bearing Numbers of Inner Ring	Boundary Dimensions (mm)	Abutment and Fillet Dimensions (mm)	approx	
Open	Closed		$d$ $B$	$d_a$ (min) $r_a$ (max)	Open	Closed
—	—	—	—	—	1.3	—
—	—	—	—	—	1.7	1.9
—	—	—	—	—	2.2	2.4
—	—	—	—	—	2.3	2.7
—	—	—	—	—	2.7	3.2
—	—	—	—	—	5.2	5.5
FH-810	MFH-810	—	—	—	6.0	6.3
—	—	—	—	—	3.2	3.6
—	—	—	—	—	5.7	6.1
FH-910	MFH-910	—	—	—	6.4	6.8
—	—	FIR-71010	7 10.5	9 0.3	3.6	4.1
—	—	FIR-71010	7 10.5	9 0.3	6.1	6.6
FH-1010	MFH-1010	FIR-71010	7 10.5	9 0.3	6.9	7.3
—	—	FIR-81210	8 10.5	10 0.3	4.1	4.5
—	—	FIR-81212	8 12.5	10 0.3	7.7	8.2
FH-1212	MFH-1212	FIR-81212	8 12.5	10 0.3	10	11
—	—	FIR-101312	10 12.5	12 0.3	8.6	9.5
F-1312	MF-1312	FIR-101312	10 12.5	12 0.3	11	12
—	—	FIR-101412	10 12.5	12 0.3	10	11
F-1412	MF-1412	FIR-101412	10 12.5	12 0.3	12	14
—	—	FIR-101416	10 16.5	12 0.3	13	14
F-1416	MF-1416	FIR-101416	10 16.5	12 0.3	18	19
—	—	FIR-121512	12 12.5	14 0.3	10	11
F-1512	MF-1512	FIR-121512	12 12.5	14 0.3	12	14
F-1514	MF-1514	—	—	—	15	16
—	—	FIR-121516	12 16.5	14 0.3	13	14
F-1516	MF-1516	FIR-121516	12 16.5	14 0.3	17	18
—	—	FIR-121612	12 12.5	14 0.3	11	12
F-1612	MF-1612	FIR-121612	12 12.5	14 0.3	14	15
—	—	FIR-121616	12 16.5	14 0.3	14	15
F-1616	MF-1616	FIR-121616	12 16.5	14 0.3	18	20

FJ • MFJ (With Cage)

F • MF (Full Complement Type)

Inscribed Circle Diameter 17~28 mm

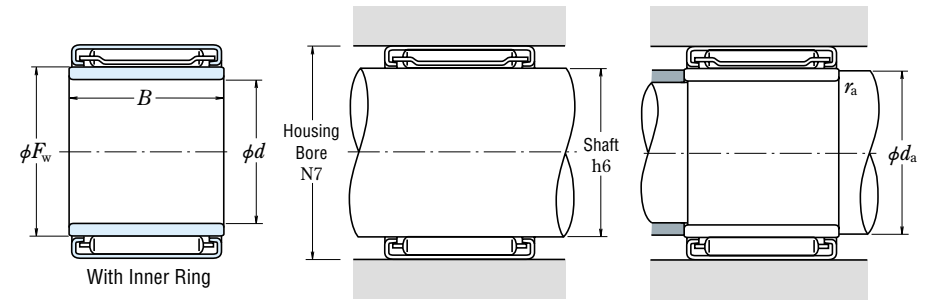
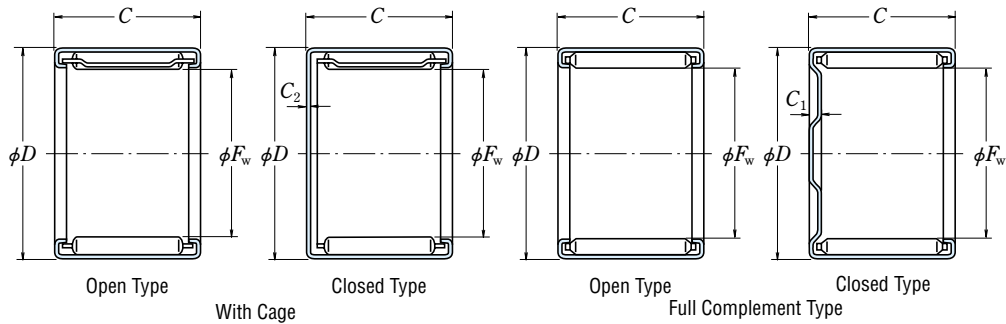

Boundary Dimensions (mm)	Basic Dynamic Load Ratings (N) {kgf}		Limiting Loads (N) {kgf}		Limiting Speeds (rpm)		Bearing				
	$F_W$	$C^{-0.25}$	$C_1, C_2$	$C_r$	$P_{max}$	Grease	Oil	With Cage			
	$D$	$C$	$C_1, C_2$	$C_r$	$P_{max}$			Open	Closed		
17	23	12	1.0	8 450	860	4 450	455	12 000	19 000	FJ-1712	MFJ-1712
	23	12	1.8	11 300	1 150	7 750	790	3 400	5 600	—	—
	23	16	1.0	12 100	1 230	7 100	720	12 000	19 000	FJ-1716	MFJ-1716
	23	16	1.8	15 800	1 610	12 000	1 220	3 400	5 600	—	—
18	24	12	1.0	7 650	780	4 200	430	11 000	18 000	FJ-1812	MFJ-1812
	24	12	2.2	10 900	1 110	7 900	805	3 000	5 000	—	—
	24	16	1.0	11 200	1 140	6 800	695	11 000	18 000	FJ-1816	MFJ-1816
	24	16	2.2	15 300	1 560	12 300	1 250	3 000	5 000	—	—
20	26	12	1.0	8 150	835	4 650	475	10 000	16 000	FJ-2012	MFJ-2012
	26	12	2.2	11 500	1 170	8 700	885	2 800	4 500	—	—
	26	16	1.0	11 900	1 210	7 550	770	10 000	16 000	FJ-2016	MFJ-2016
	26	16	2.2	16 200	1 650	13 500	1 380	2 800	4 500	—	—
22	28	12	1.0	8 650	880	5 150	525	9 000	14 000	FJ-2212	MFJ-2212
	28	12	2.2	12 100	1 230	9 500	970	2 400	4 000	—	—
	28	16	1.0	12 600	1 290	8 350	850	9 000	14 000	FJ-2216	MFJ-2216
	28	16	2.2	17 100	1 740	14 800	1 510	2 400	4 000	—	—
25	32	16	1.0	15 200	1 550	9 350	955	8 000	13 000	FJ-2516	MFJ-2516
	32	16	2.5	20 200	2 060	16 200	1 650	2 800	4 500	—	—
	32	20	1.0	19 800	2 020	13 100	1 340	8 000	13 000	FJ-2520	MFJ-2520
	32	20	2.5	25 900	2 640	22 200	2 260	2 800	4 500	—	—
28	35	16	1.0	15 600	1 590	9 950	1 020	7 100	11 000	FJ-2816	MFJ-2816
	35	16	2.5	21 300	2 170	17 900	1 820	2 400	4 000	—	—
	35	20	1.0	20 500	2 090	14 200	1 450	7 100	11 000	FJ-2820	MFJ-2820
	35	20	2.5	27 300	2 780	24 600	2 510	2 400	4 000	—	—
35	35	26	1.0	26 900	2 750	20 200	2 060	7 100	11 000	FJ-2826	MFJ-2826
	35	26	2.5	35 500	3 650	34 500	3 550	2 400	4 000	—	—

Numbers	In case of inner ring is used				Mass Without Inner Ring (g)				
	Full Complement Type		Bearing Numbers of Inner Ring	Boundary Dimensions (mm)		Abutment and Fillet Dimensions (mm)		approx	
	Open	Closed		$d$	$B$	$d_a$ (min)	$r_a$ (max)	Open	Closed
—	—	—	—	—	—	—	—	10	11
F-1712	MF-1712	—	—	—	—	—	—	14	15
—	—	—	—	—	—	—	—	14	16
F-1716	MF-1716	—	—	—	—	—	—	18	20
—	—	FIR-151812	15	12.5	17	0.3	—	12	14
F-1812	MF-1812	FIR-151812	15	12.5	17	0.3	—	14	16
—	—	FIR-151816	15	16.5	17	0.3	—	16	18
F-1816	MF-1816	FIR-151816	15	16.5	17	0.3	—	19	22
—	—	FIR-172012	17	12.5	19	0.3	—	13	15
F-2012	MF-2012	FIR-172012	17	12.5	19	0.3	—	17	19
—	—	FIR-172016	17	16.5	19	0.3	—	17	19
F-2016	MF-2016	FIR-172016	17	16.5	19	0.3	—	22	25
—	—	FIR-172020	17	20.5	19	0.3	—	22	24
F-2020	MF-2020	FIR-172020	17	20.5	19	0.3	—	28	30
—	—	FIR-172212	17	12.5	19	0.3	—	14	17
F-2212	MF-2212	FIR-172212	17	12.5	19	0.3	—	18	21
—	—	FIR-172216	17	16.5	19	0.3	—	19	22
F-2216	MF-2216	FIR-172216	17	16.5	19	0.3	—	24	27
—	—	FIR-172220	17	20.5	19	0.3	—	23	26
F-2220	MF-2220	FIR-172220	17	20.5	19	0.3	—	30	33
—	—	FIR-202516	20	16.5	22	0.3	—	24	27
F-2516	MF-2516	FIR-202516	20	16.5	22	0.3	—	31	35
—	—	FIR-202520	20	20.5	22	0.3	—	31	34
F-2520	MF-2520	FIR-202520	20	20.5	22	0.3	—	40	43
—	—	FIR-202526	20	26.5	22	0.3	—	40	43
F-2526	MF-2526	FIR-202526	20	26.5	22	0.3	—	52	55
—	—	FIR-222816	22	16.5	24	0.3	—	27	31
F-2816	MF-2816	FIR-222816	22	16.5	24	0.3	—	35	40
—	—	FIR-222820	22	20.5	24	0.3	—	34	38
F-2820	MF-2820	FIR-222820	22	20.5	24	0.3	—	44	48
—	—	FIR-222826	22	26.5	24	0.3	—	45	49
F-2826	MF-2826	FIR-222826	22	26.5	24	0.3	—	57	62

FJ • MFJ (With Cage)

F • MF (Full Complement Type)

Inscribed Circle Diameter 30~55 mm

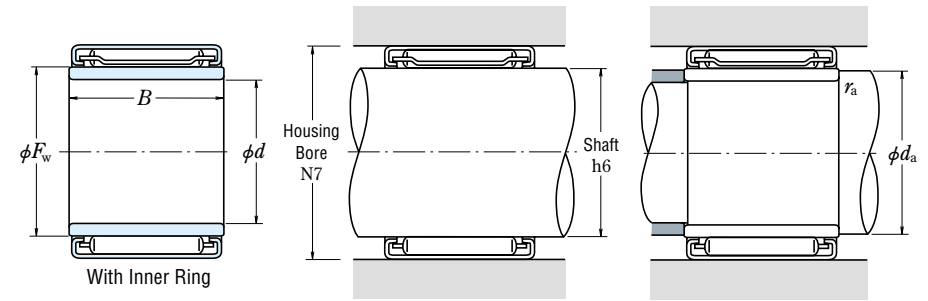
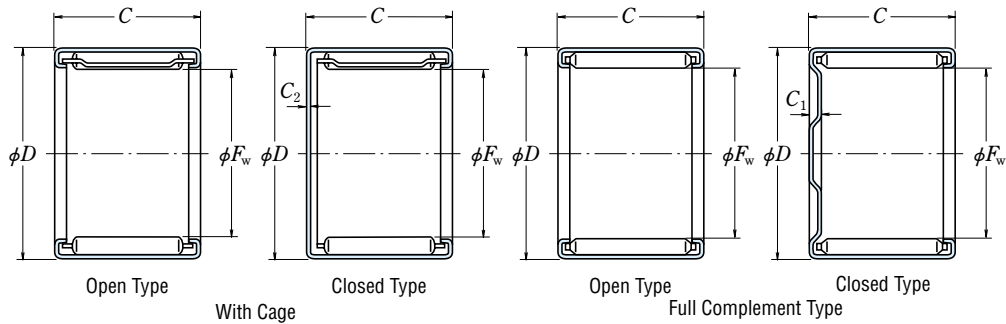

Boundary Dimensions (mm)	Basic Dynamic Load Ratings (N) {kgf}		Limiting Loads (N) {kgf}		Limiting Speeds (rpm)		Bearing				
	$F_w$	$C^{-0.25}$	$C_1, C_2$	$C_r$	$P_{max}$	Grease	Oil	With Cage			
								Open	Closed		
<b>30</b>	37	16	1.0	15 600	1 590	10 100	1 030	6 700	10 000	<b>FJ-3016L</b>	<b>MFJ-3016</b>
	37	16	2.5	22 100	2 250	18 900	1 930	2 400	3 800	—	—
	37	20	1.0	19 400	1 970	13 300	1 360	6 700	10 000	<b>FJ-3020</b>	<b>MFJ-3020</b>
	37	20	2.5	28 400	2 900	26 200	2 670	2 400	3 800	—	—
	37	26	1.0	26 000	2 660	19 500	1 990	6 700	10 000	<b>FJ-3026</b>	<b>MFJ-3026</b>
	37	26	2.5	37 000	3 800	37 000	3 750	2 400	3 800	—	—
<b>35</b>	42	16	1.0	18 100	1 850	12 800	1 300	5 600	9 000	<b>FJ-3516</b>	<b>MFJ-3516</b>
	42	16	2.5	24 000	2 450	22 000	2 240	2 000	3 400	—	—
	42	20	1.0	23 600	2 410	17 900	1 830	5 600	9 000	<b>FJ-3520</b>	<b>MFJ-3520</b>
	42	20	2.5	31 000	3 150	30 000	3 100	2 000	3 400	—	—
	42	26	1.0	31 500	3 200	25 800	2 630	5 600	9 000	<b>FJ-3526</b>	<b>MFJ-3526</b>
	42	26	2.5	40 000	4 100	42 500	4 350	2 000	3 400	—	—
<b>40</b>	47	16	1.0	18 600	1 890	13 600	1 390	4 800	7 500	<b>FJ-4016</b>	<b>MFJ-4016</b>
	47	16	2.5	25 700	2 620	24 900	2 540	1 800	3 000	—	—
	47	20	1.0	23 500	2 400	18 500	1 890	4 800	7 500	<b>FJ-4020</b>	<b>MFJ-4020</b>
	47	20	2.5	32 500	3 350	34 000	3 450	1 800	3 000	—	—
	47	26	1.0	31 500	3 200	26 900	2 740	4 800	7 500	<b>FJ-4026</b>	<b>MFJ-4026</b>
<b>45</b>	52	16	1.0	19 900	2 030	15 400	1 570	4 300	6 700	<b>FJ-4516</b>	<b>MFJ-4516</b>
	52	16	2.5	27 300	2 790	27 800	2 840	1 600	2 600	—	—
	52	20	1.0	25 500	2 600	21 200	2 160	4 300	6 700	<b>FJ-4520</b>	<b>MFJ-4520</b>
	52	20	2.5	35 000	3 550	38 500	3 900	1 600	2 600	—	—
<b>50</b>	58	20	1.1	28 900	2 940	23 100	2 350	3 800	6 300	<b>FJ-5020L</b>	<b>MFJ-5020</b>
	58	20	2.8	39 500	4 050	41 500	4 250	1 700	2 800	—	—
	58	24	1.1	36 000	3 700	30 500	3 150	3 800	6 300	<b>FJ-5024</b>	<b>MFJ-5024</b>
	58	24	2.8	48 000	4 900	53 000	5 400	1 700	2 800	—	—
<b>55</b>	63	20	1.1	30 000	3 100	25 100	2 560	3 400	5 600	<b>FJ-5520</b>	<b>MFJ-5520</b>
	63	20	2.8	41 500	4 250	45 500	4 650	1 600	2 400	—	—
	63	24	1.1	37 500	3 850	33 500	3 400	3 400	5 600	<b>FJ-5524</b>	<b>MFJ-5524</b>
	63	24	2.8	50 500	5 150	58 000	5 950	1 600	2 400	—	—

Numbers	In case of inner ring is used				Mass Without Inner Ring (g)			
	Full Complement Type		Bearing Numbers of Inner Ring	Boundary Dimensions (mm)		approx		
	Open	Closed		$d$	$B$	Open	Closed	
—	—	—	—	—	—	26	31	
<b>F-3016</b>	<b>MF-3016</b>	—	—	—	—	35	40	
—	—	<b>FIR-253020</b>	25	20.5	27	0.3	35	39
<b>F-3020</b>	<b>MF-3020</b>	<b>FIR-253020</b>	25	20.5	27	0.3	46	51
—	—	<b>FIR-253026</b>	25	26.5	27	0.3	46	50
<b>F-3026</b>	<b>MF-3026</b>	<b>FIR-253026</b>	25	26.5	27	0.3	61	66
—	—	—	—	—	—	32	38	
<b>F-3516</b>	<b>MF-3516</b>	—	—	—	—	53	60	
—	—	<b>FIR-303520</b>	30	20.5	34	0.6	41	45
<b>F-3520</b>	<b>MF-3520</b>	<b>FIR-303520</b>	30	20.5	34	0.6	42	49
—	—	<b>FIR-303526</b>	30	26.5	34	0.6	54	58
<b>F-3526</b>	<b>MF-3526</b>	<b>FIR-303526</b>	30	26.5	34	0.6	70	76
—	—	—	—	—	—	34	43	
<b>F-4016</b>	<b>MF-4016</b>	—	—	—	—	48	56	
—	—	<b>FIR-354020</b>	35	20.5	39	0.6	46	51
<b>F-4020</b>	<b>MF-4020</b>	<b>FIR-354020</b>	35	20.5	39	0.6	60	69
—	—	<b>FIR-354026</b>	35	26.5	39	0.6	60	65
—	—	—	—	—	—	39	50	
<b>F-4516</b>	<b>MF-4516</b>	—	—	—	—	53	64	
—	—	<b>FIR-404520</b>	40	20.5	44	0.6	53	59
<b>F-4520</b>	<b>MF-4520</b>	<b>FIR-404520</b>	40	20.5	44	0.6	67	78
—	—	—	—	—	—	56	71	
<b>F-5020</b>	<b>MF-5020</b>	<b>FIR-455020</b>	45	20.5	49	0.6	81	95
—	—	—	—	—	—	69	84	
<b>F-5024</b>	<b>MF-5024</b>	—	—	—	—	98	110	
—	—	—	—	—	—	60	79	
<b>F-5520</b>	<b>MF-5520</b>	—	—	—	—	88	105	
—	—	—	—	—	—	72	90	
<b>F-5524</b>	<b>MF-5524</b>	—	—	—	—	105	125	

RLM · LM

RNA · NA

Inscribed Circle Diameter 9~22 mm

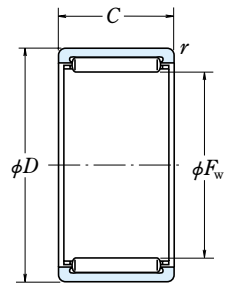

RLM

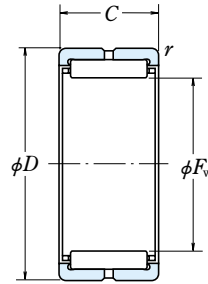

RNA

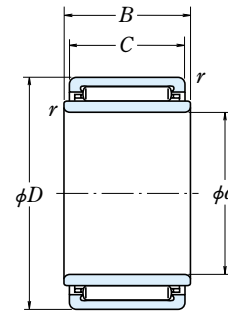

LM

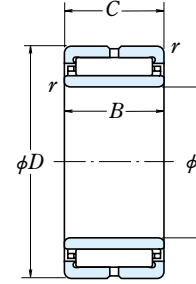

NA

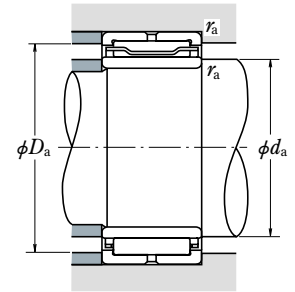

F <sub>W</sub>	Boundary Dimensions (mm)			Basic Load Ratings (N)				Limiting Speeds (rpm)		Bearing
	D	C	r <sub>min</sub>	C <sub>r</sub>	C <sub>0r</sub>	{kgf}		Grease	Oil	
9	16	12	0.3	6 150	5 400	625	550	24 000	40 000	RLM 912 RLM 916
	16	16	0.3	7 900	7 450	805	760	24 000	40 000	
10	17	10	0.3	5 350	4 650	545	470	22 000	36 000	RLM 101710 RLM 101715
	17	15	0.3	8 050	7 800	820	795	22 000	36 000	
12	17	12	0.3	6 150	7 650	625	780	18 000	30 000	RLM 1212 RLM 121912
	19	12	0.3	7 300	7 150	745	730	18 000	30 000	
14	22	13	0.3	9 150	9 950	930	1 010	20 000	32 000	— RLM 1416 RLM 1420
	22	16	0.3	12 100	12 700	1 230	1 300	15 000	24 000	
	22	20	0.3	15 500	17 500	1 580	1 790	15 000	24 000	
15	20	15	0.3	8 100	11 700	825	1 190	14 000	24 000	RLM 1515 RLM 1520 RLM 152215
	20	20	0.3	11 100	17 400	1 130	1 770	14 000	24 000	
	22	15	0.3	9 900	11 100	1 010	1 140	14 000	24 000	
16	24	13	0.3	10 100	11 700	1 030	1 190	17 000	28 000	— RLM 1616 RLM 1620 —
	24	16	0.3	12 900	14 200	1 310	1 450	13 000	22 000	
	24	20	0.3	16 500	19 500	1 680	1 990	13 000	22 000	
	24	22	0.3	17 900	24 500	1 830	2 500	17 000	28 000	
17	22	10	0.3	5 850	7 950	595	810	13 000	20 000	RLM 1710 RLM 172425
	24	25	0.5	18 200	25 300	1 850	2 580	13 000	20 000	
18	25	15	0.5	11 500	14 300	1 170	1 450	12 000	20 000	RLM 1815 RLM 1820
	25	20	0.5	15 800	21 500	1 610	2 190	12 000	20 000	
20	27	10	0.5	7 950	9 150	810	930	11 000	18 000	RLM 2010 RLM 2015 RLM 2020 RLM 2025 —
	27	15	0.5	11 900	15 400	1 220	1 570	11 000	18 000	
	27	20	0.5	16 400	23 200	1 670	2 370	11 000	18 000	
	27	25	0.5	19 800	29 500	2 010	3 000	11 000	18 000	
	28	13	0.3	10 800	13 600	1 100	1 390	13 000	22 000	
22	28	18	0.3	15 700	21 900	1 600	2 240	13 000	22 000	— — —
	28	23	0.3	19 300	28 600	1 960	2 920	13 000	22 000	
	29	20	0.5	17 700	26 400	1 810	2 690	10 000	16 000	
30	29	25	0.5	21 300	33 500	2 170	3 400	10 000	16 000	RLM 2220 RLM 2225 — — — RLM 223020 —
	30	13	0.3	11 600	15 400	1 190	1 570	12 000	20 000	
	30	18	0.3	16 800	24 800	1 720	2 530	12 000	20 000	
	30	20	0.5	20 000	27 200	2 030	2 780	10 000	16 000	
	30	23	0.3	20 700	32 500	2 110	3 300	12 000	20 000	

Remarks If a full complement roller bearing is required, please contact NSK.

Numbers		Boundary Dimensions (mm)		Abutment and Fillet Dimensions (mm)			Mass (kg)	
Without Inner Ring	With Inner Ring	d	B	d <sub>a</sub> min	D <sub>a</sub> max	r <sub>a</sub> max	approx	
—	LM 91612-1	6	12	8	14	0.3	0.009	0.013
—	—	—	—	—	14	0.3	0.011	—
—	—	—	—	—	15	0.3	0.008	—
—	—	—	—	—	15	0.3	0.012	—
—	LM 1212	8	12.2	10	15	0.3	0.007	0.013
—	LM 121912	8	12.2	10	17	0.3	0.011	0.017
RNA 4900	NA 4900	10	13	12	20	0.3	0.016	0.024
—	LM 1416	10	16.2	12	20	0.3	0.019	0.028
—	LM 1420	10	20.2	12	20	0.3	0.024	0.036
—	LM 1515	10	15.2	12	18	0.3	0.011	0.022
—	LM 1520	10	20.2	12	18	0.3	0.015	0.03
—	LM 152215	10	15.2	12	20	0.3	0.016	0.027
RNA 4901	NA 4901	12	13	14	22	0.3	0.018	0.027
—	LM 1616	12	16.2	14	22	0.3	0.021	0.032
—	LM 1620	12	20.2	14	22	0.3	0.027	0.041
RNA 6901	NA 6901	12	22	14	22	0.3	0.03	0.045
—	LM 1710	12	10.2	14	20	0.3	0.008	0.017
—	LM 172425	12	25.2	16	20	0.5	0.03	0.052
—	LM 1815	15	15.2	19	21	0.5	0.019	0.028
—	LM 1820	15	20.2	19	21	0.5	0.025	0.037
—	LM 2010	15	10.2	19	23	0.5	0.014	0.025
—	LM 2015	15	15.2	19	23	0.5	0.021	0.037
—	LM 2020	15	20.2	19	23	0.5	0.028	0.049
—	LM 2025	15	25.2	19	23	0.5	0.035	0.061
RNA 4902	NA 4902	15	13	17	26	0.3	0.021	0.035
RNA 5902	NA 5902	15	18	17	26	0.3	0.032	0.051
RNA 6902	NA 6902	15	23	17	26	0.3	0.039	0.064
—	LM 2220	17	20.2	21	25	0.5	0.03	0.054
—	LM 2225	17	25.2	21	25	0.5	0.038	0.068
RNA 4903	NA 4903	17	13	19	28	0.3	0.023	0.038
RNA 5903	NA 5903	17	18	19	28	0.3	0.034	0.055
—	LM 223020	17	20.2	21	26	0.5	0.035	0.06
RNA 6903	NA 6903	17	23	19	28	0.3	0.041	0.068



RLM • LM  
RNA • NA  
Inscribed Circle Diameter 25~35 mm

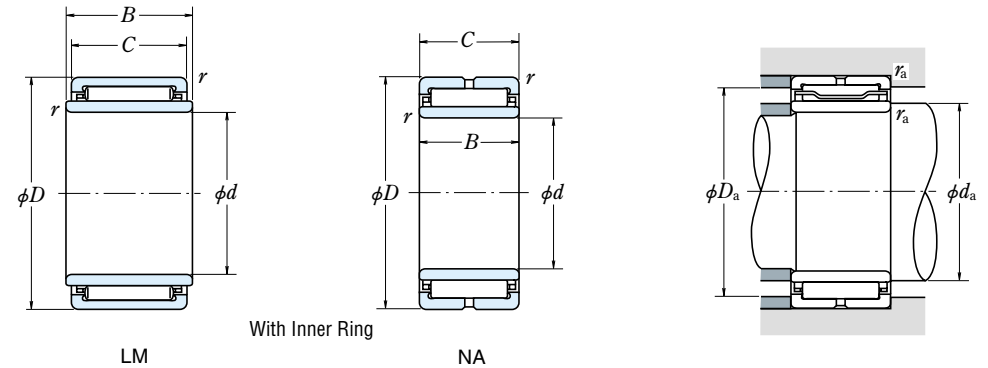
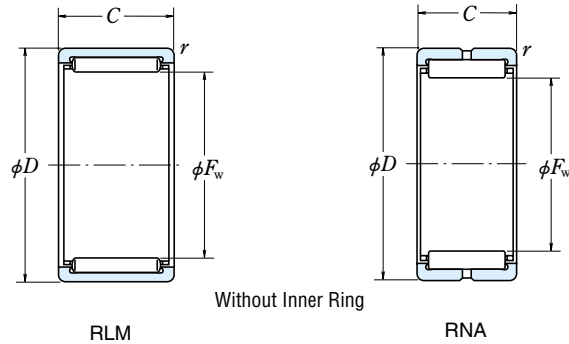

Boundary Dimensions (mm)				Basic Load Ratings (N)				Limiting Speeds (rpm)		Bearing
$F_w$	$D$	$C$	$r_{min}$	$C_r$	$C_{0r}$	{kgf}		Grease	Oil	
25	32	12	0.5	10 300	13 700	1 050	1 400	8 500	14 000	RLM 2512 RLM 2520 RLM 2525
	32	20	0.5	18 800	29 700	1 920	3 050	8 500	14 000	
	32	25	0.5	22 700	37 500	2 310	3 850	8 500	14 000	
28	37	17	0.3	19 700	22 900	2 010	2 340	11 000	18 000	— — —
	37	23	0.3	27 800	35 500	2 830	3 650	11 000	18 000	
	37	30	0.3	36 500	50 500	3 700	5 150	11 000	18 000	
30	35	20	0.5	19 900	33 000	2 030	3 350	7 500	12 000	RLM 2820 RLM 2825 RLM 283730
	35	25	0.5	23 900	42 000	2 440	4 250	7 500	12 000	
	37	30	0.5	34 000	52 500	3 450	5 350	7 500	12 000	
32	39	17	0.3	22 400	30 500	2 290	3 150	9 500	15 000	— — —
	39	23	0.3	28 300	41 500	2 890	4 200	9 500	15 000	
	39	30	0.3	37 000	58 500	3 800	6 000	9 500	15 000	
35	37	25	0.5	24 500	44 000	2 490	4 500	7 100	12 000	RLM 3025 RLM 304020 RLM 304030
	40	20	0.5	25 000	36 000	2 550	3 650	7 100	12 000	
	40	30	0.5	35 000	56 000	3 600	5 700	7 100	12 000	
32	42	17	0.3	21 400	26 800	2 180	2 740	9 000	14 000	— — —
	42	23	0.3	30 000	41 500	3 100	4 250	9 000	14 000	
	42	30	0.3	39 500	59 000	4 050	6 050	9 000	14 000	
33	42	20	0.5	25 800	38 000	2 630	3 900	6 700	11 000	RLM 3220 RLM 3230
	42	30	0.5	36 500	59 000	3 700	6 050	6 700	11 000	
	45	17	0.3	22 200	28 700	2 270	2 930	8 500	13 000	
35	45	23	0.3	31 500	44 500	3 200	4 550	8 500	13 000	— — —
	45	30	0.3	41 000	63 500	4 200	6 450	8 500	13 000	
	42	20	0.5	22 300	41 000	2 270	4 200	6 300	10 000	
35	42	30	0.5	31 000	63 500	3 200	6 450	6 300	10 000	RLM 3520 RLM 3530
	45	20	0.5	27 500	42 500	2 800	4 350	6 300	10 000	
	45	25	0.5	33 000	54 500	3 400	5 550	6 300	10 000	
35	45	30	0.5	38 500	66 000	3 950	6 750	6 300	10 000	RLM 354520 RLM 354525 RLM 354530
	47	17	0.3	23 900	32 500	2 430	3 300	7 500	12 000	
	47	23	0.3	33 500	50 500	3 450	5 150	7 500	12 000	
35	47	30	0.3	44 000	71 500	4 500	7 300	7 500	12 000	— — —

Numbers		Boundary Dimensions (mm)		Abutment and Fillet Dimensions (mm)			Mass (kg)	
Without Inner Ring	With Inner Ring	$d$	$B$	$d_a$ min	$D_a$ max	$r_a$ max	approx	
—	LM 2512	20	12.2	24	28	0.5	0.02	0.036
—	LM 2520	20	20.2	24	28	0.5	0.034	0.061
—	LM 2525	20	25.2	24	28	0.5	0.042	0.076
RNA 4904	NA 4904	20	17	22	35	0.3	0.055	0.077
RNA 5904	NA 5904	20	23	22	35	0.3	0.089	0.12
RNA 6904	NA 6904	20	30	22	35	0.3	0.098	0.14
—	LM 2820	22	20.2	26	31	0.5	0.038	0.062
—	LM 2825	22	25.2	26	31	0.5	0.047	0.092
—	LM 283730	22	30.2	26	33	0.5	0.075	0.13
RNA 49/22	NA 49/22	22	17	24	37	0.3	0.056	0.086
RNA 59/22	NA 59/22	22	23	24	37	0.3	0.091	0.135
RNA 69/22	NA 69/22	22	30	24	37	0.3	0.096	0.15
—	LM 3025	25	25.2	29	33	0.5	0.05	0.092
—	LM 304020	25	20.2	29	36	0.5	0.06	0.093
—	LM 304030	25	30.2	29	36	0.5	0.09	0.14
RNA 4905	NA 4905	25	17	27	40	0.3	0.063	0.091
RNA 5905	NA 5905	25	23	27	40	0.3	0.10	0.14
RNA 6905	NA 6905	25	30	27	40	0.3	0.11	0.16
—	LM 3220	28	20.2	32	38	0.5	0.064	0.09
—	LM 3230	28	30.2	32	38	0.5	0.096	0.14
RNA 49/28	NA 49/28	28	17	30	43	0.3	0.076	0.099
RNA 59/28	NA 59/28	28	23	30	43	0.3	0.11	0.145
RNA 69/28	NA 69/28	28	30	30	43	0.3	0.13	0.175
—	LM 3520	30	20.2	34	38	0.5	0.046	0.085
—	LM 3530	30	30.2	34	38	0.5	0.07	0.13
—	LM 354520	30	20.2	34	41	0.5	0.069	0.11
—	LM 354525	30	25.2	34	41	0.5	0.086	0.135
—	LM 354530	30	30.2	34	41	0.5	0.10	0.16
RNA 4906	NA 4906	30	17	32	45	0.3	0.072	0.105
RNA 5906	NA 5906	30	23	32	45	0.3	0.11	0.15
RNA 6906	NA 6906	30	30	32	45	0.3	0.13	0.19

Remarks If a full complement roller bearing is required, please contact NSK.

**RLM · LM**  
**RNA · NA**  
 Inscribed Circle Diameter 37~58 mm

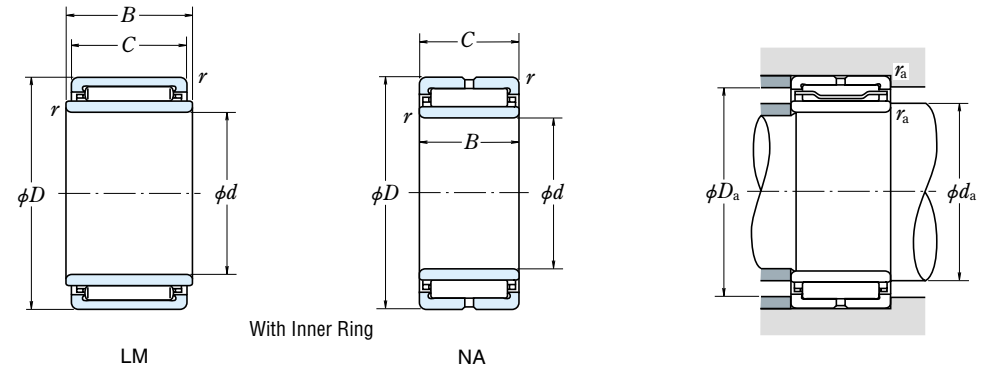
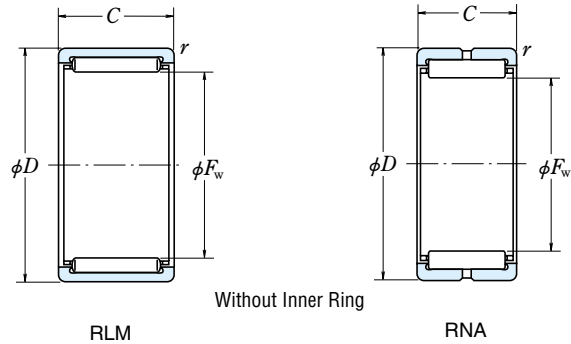

F <sub>W</sub>	Boundary Dimensions (mm)			Basic Load Ratings (N)				Limiting Speeds (rpm)		Bearing
	D	C	r <sub>min</sub>	C <sub>r</sub>	C <sub>0r</sub>	C <sub>r</sub>	C <sub>0r</sub>	Grease	Oil	
37	47	20	0.6	28 200	45 000	2 880	4 550	6 000	9 500	RLM 3720 RLM 3730
	47	30	0.6	39 500	69 500	4 050	7 100	6 000	9 500	
38	48	20	0.6	29 000	47 000	2 960	4 800	5 600	9 000	RLM 3820 RLM 3830
	48	30	0.6	41 000	73 000	4 150	7 450	5 600	9 000	
40	50	20	0.6	29 700	49 000	3 050	5 000	5 300	9 000	RLM 4020 RLM 4030
	50	30	0.6	42 000	76 500	4 250	7 800	5 300	9 000	
42	52	20	0.6	29 900	45 000	3 050	4 600	6 700	10 000	—
	52	27	0.6	40 500	66 000	4 100	6 750	6 700	10 000	
	52	36	0.6	56 000	101 000	5 700	10 300	6 700	10 000	
45	55	20	0.6	30 500	47 500	3 100	4 800	6 300	10 000	—
	55	27	0.6	41 500	69 500	4 200	7 100	6 300	10 000	
	55	36	0.6	57 500	106 000	5 850	10 900	6 300	10 000	
48	62	22	0.6	31 000	53 500	3 150	5 500	4 800	8 000	RLM 4520 RLM 4530
	62	30	0.6	43 500	83 500	4 450	8 500	4 800	8 000	
50	62	22	0.6	39 000	61 500	3 950	6 300	5 600	9 000	—
	62	30	0.6	54 500	95 000	5 550	9 700	5 600	9 000	
	62	40	0.6	72 000	137 000	7 350	13 900	5 600	9 000	
52	62	20	0.6	35 500	60 500	3 600	6 150	4 300	7 100	RLM 506220 RLM 506225
	62	25	0.6	43 000	77 500	4 400	7 900	4 300	7 100	
55	68	22	0.6	41 000	67 500	4 150	6 900	5 000	8 000	—
	68	30	0.6	57 000	104 000	5 800	10 600	5 000	8 000	
	68	40	0.6	76 000	149 000	7 750	15 200	5 000	8 000	
58	65	30	0.6	49 000	104 000	5 000	10 600	4 000	6 300	RLM 5530 RLM 556720
	67	20	0.6	38 000	68 000	3 850	6 900	4 000	6 300	
58	72	22	0.6	42 500	73 500	4 350	7 500	4 500	7 100	—
	72	30	0.6	59 500	113 000	6 050	11 500	4 500	7 100	
	72	40	0.6	79 000	163 000	8 050	16 600	4 500	7 100	

Numbers		Boundary Dimensions (mm)		Abutment and Fillet Dimensions (mm)			Mass (kg)	
Without Inner Ring	With Inner Ring	d	B	d <sub>a</sub> min	D <sub>a</sub> max	r <sub>a</sub> max	approx	
—	LM 3720	32	20.3	36	43	0.6	0.072	0.115
—	LM 3730	32	30.3	36	43	0.6	0.11	0.17
—	LM 3820	32	20.3	36	44	0.6	0.074	0.125
—	LM 3830	32	30.3	36	44	0.6	0.11	0.195
—	LM 4020	35	20.3	39	46	0.6	0.078	0.125
—	LM 4030	35	30.3	39	46	0.6	0.12	0.19
RNA 49/32	NA 49/32	32	20	36	48	0.6	0.092	0.16
RNA 59/32	NA 59/32	32	27	36	48	0.6	0.15	0.24
RNA 69/32	NA 69/32	32	36	36	48	0.6	0.17	0.29
RNA 4907	NA 4907	35	20	39	51	0.6	0.11	0.17
RNA 5907	NA 5907	35	27	39	51	0.6	0.175	0.25
RNA 6907	NA 6907	35	36	39	51	0.6	0.20	0.315
—	LM 4520	40	20.3	44	51	0.6	0.086	0.14
—	LM 4530	40	30.3	44	51	0.6	0.13	0.21
RNA 4908	NA 4908	40	22	44	58	0.6	0.15	0.24
RNA 5908	NA 5908	40	30	44	58	0.6	0.23	0.355
RNA 6908	NA 6908	40	40	44	58	0.6	0.265	0.435
—	LM 506220	42	20.3	46	58	0.6	0.12	0.21
—	LM 506225	42	25.3	46	58	0.6	0.155	0.265
RNA 4909	NA 4909	45	22	49	64	0.6	0.19	0.28
RNA 5909	NA 5909	45	30	49	64	0.6	0.27	0.39
RNA 6909	NA 6909	45	40	49	64	0.6	0.335	0.495
—	LM 5530	45	30.3	49	61	0.6	0.16	0.34
—	LM 556720	45	20.3	49	63	0.6	0.13	0.25
RNA 4910	NA 4910	50	22	54	68	0.6	0.18	0.295
RNA 5910	NA 5910	50	30	54	68	0.6	0.25	0.405
RNA 6910	NA 6910	50	40	54	68	0.6	0.32	0.53

**Remarks** If a full complement roller bearing is required, please contact NSK.

RNA · NA  
Inscribed Circle Diameter 63~120 mm

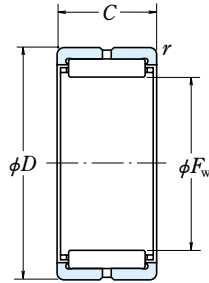

Without Inner Ring  
RNA

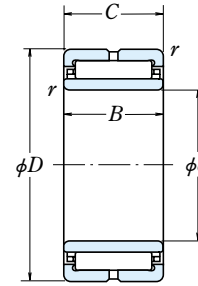

With Inner Ring  
NA

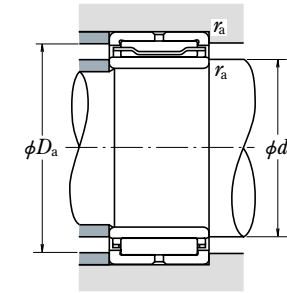

Boundary Dimensions (mm)	Basic Load Ratings				Limiting Speeds (rpm)		Bearing			
	$F_w$	$D$	$C$	$r_{min}$	(N)	{kgf}		Grease	Oil	
				$C_r$	$C_{0r}$	$C_r$	$C_{0r}$		Without Inner Ring	
<b>63</b>	80	25	1	53 500	87 500	5 450	8 950	4 000	6 700	<b>RNA 4911</b>
	80	34	1	73 500	133 000	7 500	13 600	4 000	6 700	<b>RNA 5911</b>
	80	45	1	93 500	181 000	9 550	18 500	4 000	6 700	<b>RNA 6911</b>
<b>68</b>	85	25	1	56 000	95 500	5 700	9 750	3 800	6 300	<b>RNA 4912</b>
	85	34	1	77 500	145 000	7 900	14 800	3 800	6 300	<b>RNA 5912</b>
	85	45	1	98 000	197 000	10 000	20 100	3 800	6 300	<b>RNA 6912</b>
<b>72</b>	90	25	1	58 500	103 000	5 950	10 500	3 600	5 600	<b>RNA 4913</b>
	90	34	1	81 000	157 000	8 250	16 000	3 600	5 600	<b>RNA 5913</b>
	90	45	1	103 000	213 000	10 500	21 800	3 600	5 600	<b>RNA 6913</b>
<b>80</b>	100	30	1	80 500	143 000	8 200	14 600	3 200	5 300	<b>RNA 4914</b>
	100	40	1	107 000	206 000	10 900	21 000	3 200	5 300	<b>RNA 5914</b>
	100	54	1	143 000	298 000	14 500	30 500	3 200	5 300	<b>RNA 6914</b>
<b>85</b>	105	30	1	84 000	155 000	8 600	15 800	3 000	5 000	<b>RNA 4915</b>
	105	40	1	112 000	222 000	11 400	22 700	3 000	5 000	<b>RNA 5915</b>
	105	54	1	149 000	325 000	15 200	33 000	3 000	5 000	<b>RNA 6915</b>
<b>90</b>	110	30	1	87 500	166 000	8 950	17 000	2 800	4 500	<b>RNA 4916</b>
	110	40	1	116 000	239 000	11 900	24 400	2 800	4 500	<b>RNA 5916</b>
	110	54	1	157 000	350 000	16 000	36 000	2 800	4 500	<b>RNA 6916</b>
<b>100</b>	120	35	1.1	104 000	214 000	10 600	21 800	2 600	4 000	<b>RNA 4917</b>
	120	46	1.1	138 000	310 000	14 100	31 500	2 600	4 000	<b>RNA 5917</b>
	120	63	1.1	174 000	415 000	17 800	42 500	2 600	4 000	<b>RNA 6917</b>
<b>105</b>	125	35	1.1	108 000	228 000	11 000	23 300	2 400	4 000	<b>RNA 4918</b>
	125	46	1.1	143 000	330 000	14 600	33 500	2 400	4 000	<b>RNA 5918</b>
	125	63	1.1	181 000	445 000	18 400	45 000	2 400	4 000	<b>RNA 6918</b>
<b>110</b>	130	35	1.1	111 000	242 000	11 400	24 700	2 200	3 800	<b>RNA 4919</b>
	130	46	1.1	148 000	350 000	15 100	35 500	2 200	3 800	<b>RNA 5919</b>
	130	63	1.1	187 000	470 000	19 100	48 000	2 200	3 800	<b>RNA 6919</b>
<b>115</b>	140	40	1.1	144 000	295 000	14 700	30 000	2 200	3 600	<b>RNA 4920</b>
	140	54	1.1	193 000	430 000	19 700	43 500	2 200	3 600	<b>RNA 5920</b>
	120	30	1	99 500	214 000	10 100	21 900	2 000	3 400	<b>RNA 4822</b>

Remarks If a full complement roller bearing is required, please contact NSK.

Numbers	Boundary Dimensions (mm)		Abutment and Fillet Dimensions (mm)			Mass (kg)	
	$d$	$B$	$d_a$ min	$D_a$ max	$r_a$ max	Without Inner Ring	With Inner Ring
<b>NA 4911</b>	55	25	60	75	1	0.26	0.40
	55	34	60	75	1	0.37	0.56
	55	45	60	75	1	0.475	0.73
<b>NA 4912</b>	60	25	65	80	1	0.28	0.435
	60	34	65	80	1	0.415	0.625
	60	45	65	80	1	0.485	0.76
<b>NA 4913</b>	65	25	70	85	1	0.32	0.465
	65	34	70	85	1	0.48	0.675
	65	45	70	85	1	0.53	0.79
<b>NA 4914</b>	70	30	75	95	1	0.47	0.74
	70	40	75	95	1	0.69	1.05
	70	54	75	95	1	0.89	1.4
<b>NA 4915</b>	75	30	80	100	1	0.5	0.79
	75	40	80	100	1	0.735	1.1
	75	54	80	100	1	0.96	1.5
<b>NA 4916</b>	80	30	85	105	1	0.53	0.835
	80	40	85	105	1	0.75	1.15
	80	54	85	105	1	0.99	1.55
<b>NA 4917</b>	85	35	91.5	113.5	1	0.68	1.25
	85	46	91.5	113.5	1	0.99	1.75
	85	63	91.5	113.5	1	1.2	2.25
<b>NA 4918</b>	90	35	96.5	118.5	1	0.72	1.35
	90	46	96.5	118.5	1	1.05	1.85
	90	63	96.5	118.5	1	1.35	2.45
<b>NA 4919</b>	95	35	101.5	123.5	1	0.74	1.4
	95	46	101.5	123.5	1	1.15	2.0
	95	63	101.5	123.5	1	1.5	2.65
<b>NA 4920</b>	100	40	106.5	133.5	1	1.15	1.95
	100	54	106.5	133.5	1	1.8	2.85
	110	30	115	135	1	0.67	1.1

**RNA · NA**  
Inscribed Circle Diameter 125~390 mm

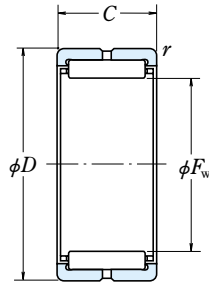

Without Inner Ring  
RNA

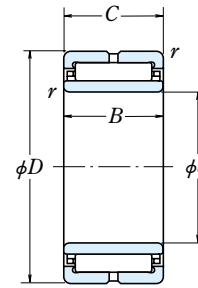

With Inner Ring  
NA

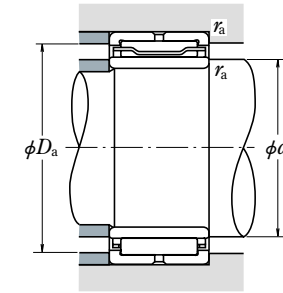

Boundary Dimensions (mm)				Basic Load Ratings (N) (kgf)				Limiting Speeds (rpm)		Bearing
$F_w$	$D$	$C$	$r_{min}$	$C_r$	$C_{0r}$	$C_r$	$C_{0r}$	Grease	Oil	
<b>125</b>	150	40	1.1	149 000	315 000	15 200	32 500	2 000	3 200	<b>RNA 4922</b> <b>RNA 5922</b>
	150	54	1.1	200 000	460 000	20 300	47 000	2 000	3 200	
<b>130</b>	150	30	1	105 000	238 000	10 700	24 300	1 900	3 200	<b>RNA 4824</b>
<b>135</b>	165	45	1.1	192 000	395 000	19 600	40 500	1 900	3 000	<b>RNA 4924</b> <b>RNA 5924</b>
	165	60	1.1	253 000	565 000	25 800	58 000	1 900	3 000	
<b>145</b>	165	35	1.1	127 000	315 000	12 900	32 000	1 700	2 800	<b>RNA 4826</b>
<b>150</b>	180	50	1.5	228 000	515 000	23 200	52 500	1 700	2 800	<b>RNA 4926</b> <b>RNA 5926</b>
	180	67	1.5	299 000	725 000	30 500	74 000	1 700	2 800	
<b>155</b>	175	35	1.1	133 000	340 000	13 600	35 000	1 600	2 600	<b>RNA 4828</b>
<b>160</b>	190	50	1.5	235 000	545 000	24 000	55 500	1 600	2 600	<b>RNA 4928</b> <b>RNA 5928</b>
	190	67	1.5	310 000	775 000	31 500	79 000	1 600	2 600	
<b>165</b>	190	40	1.1	180 000	440 000	18 300	45 000	1 500	2 400	<b>RNA 4830</b>
<b>175</b> <b>185</b> <b>195</b>	200	40	1.1	184 000	465 000	18 700	47 000	1 400	2 200	<b>RNA 4832</b> <b>RNA 4834</b> <b>RNA 4836</b>
	215	45	1.1	224 000	540 000	22 900	55 000	1 400	2 200	
	225	45	1.1	230 000	570 000	23 500	58 000	1 300	2 000	
<b>210</b> <b>220</b> <b>240</b>	240	50	1.5	268 000	705 000	27 300	72 000	1 200	1 900	<b>RNA 4838</b> <b>RNA 4840</b> <b>RNA 4844</b>
	250	50	1.5	274 000	740 000	27 900	75 500	1 100	1 800	
	270	50	1.5	286 000	805 000	29 100	82 000	1 000	1 700	
<b>265</b> <b>285</b> <b>305</b>	300	60	2	375 000	1 070 000	38 500	109 000	950	1 500	<b>RNA 4848</b> <b>RNA 4852</b> <b>RNA 4856</b>
	320	60	2	395 000	1 160 000	40 000	118 000	900	1 400	
	350	69	2	510 000	1 390 000	52 000	142 000	800	1 300	
<b>330</b> <b>350</b> <b>370</b> <b>390</b>	380	80	2.1	660 000	1 810 000	67 500	185 000	750	1 200	<b>RNA 4860</b> <b>RNA 4864</b> <b>RNA 4868</b> <b>RNA 4872</b>
	400	80	2.1	675 000	1 900 000	69 000	194 000	710	1 100	
	420	80	2.1	690 000	1 990 000	70 500	203 000	670	1 100	
	440	80	2.1	705 000	2 080 000	72 000	212 000	630	1 000	

**Remarks** If a full complement roller bearing is required, please contact NSK.

Numbers	Boundary Dimensions (mm)		Abutment and Fillet Dimensions (mm)			Mass (kg)	
	$d$	$B$	$d_a$ min	$D_a$ max	$r_a$ max	Without Inner Ring	With Inner Ring
<b>NA 4922</b> <b>NA 5922</b>	110	40	116.5	143.5	1	1.25	2.1
	110	54	116.5	143.5	1	1.95	3.05
<b>NA 4824</b>	120	30	125	145	1	0.71	1.15
<b>NA 4924</b> <b>NA 5924</b>	120	45	126.5	158.5	1	1.9	2.9
	120	60	126.5	158.5	1	2.7	4.05
<b>NA 4826</b>	130	35	136.5	158.5	1	0.92	1.8
<b>NA 4926</b> <b>NA 5926</b>	130	50	138	172	1.5	2.3	4.0
	130	67	138	172	1.5	3.3	5.55
<b>NA 4828</b>	140	35	146.5	168.5	1	0.98	1.9
<b>NA 4928</b> <b>NA 5928</b>	140	50	148	182	1.5	2.45	4.25
	140	67	148	182	1.5	3.55	6.0
<b>NA 4830</b>	150	40	156.5	183.5	1	1.6	2.75
<b>NA 4832</b> <b>NA 4834</b> <b>NA 4836</b>	160	40	166.5	193.5	1	1.75	2.95
	170	45	176.5	208.5	1	2.55	4.0
	180	45	186.5	218.5	1	2.65	4.2
<b>NA 4838</b> <b>NA 4840</b> <b>NA 4844</b>	190	50	198	232	1.5	3.2	5.6
	200	50	208	242	1.5	3.35	5.9
	220	50	228	262	1.5	3.65	6.45
<b>NA 4848</b> <b>NA 4852</b> <b>NA 4856</b>	240	60	249	291	2	5.45	10
	260	60	269	311	2	5.9	11
	280	69	289	341	2	9.5	15.5
<b>NA 4860</b> <b>NA 4864</b> <b>NA 4868</b> <b>NA 4872</b>	300	80	311	369	2	13	22
	320	80	331	389	2	13.5	23.5
	340	80	351	409	2	14	24.5
	360	80	371	429	2	15	26

FNTA (Thrust Cage & Needle Roller Assemblies)

Thrust raceway washers

FTRA (s=1.0)

FTRB (s=1.5)

FTRC (s=2.0)

FTRD (s=2.5)

FTRE (s=3.0)

Bore Diameter 10~100 mm

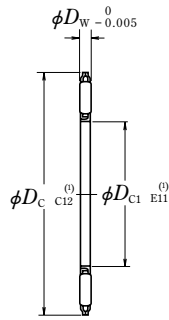

FNTA

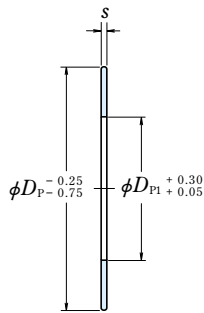

FTRA



FTRB



FTRC



FTRD



FTRE

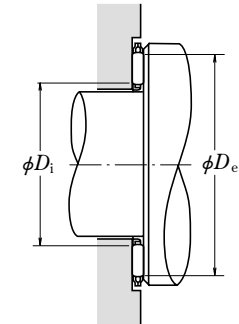

Boundary Dimensions (mm)				Basic Load Ratings				Limiting Speeds (rpm)	Bearing Numbers	s=1.0±0.05
D <sub>C1</sub> , D <sub>P1</sub>	D <sub>C</sub> , D <sub>P</sub>	D <sub>W</sub>	C <sub>a</sub>	C <sub>0a</sub>	C <sub>a</sub>	C <sub>0a</sub>	Oil			
10	24	2	7 750	23 000	790	2 350	17 000	<b>FNTA-1024</b>	*FTRA-1024	
12	26	2	8 350	26 300	855	2 680	16 000	<b>FNTA-1226</b>	FTRA-1226	
15	28	2	7 950	25 800	810	2 630	15 000	<b>FNTA-1528</b>	FTRA-1528	
16	29	2	8 200	27 100	835	2 770	14 000	<b>FNTA-1629</b>	FTRA-1629	
17	30	2	8 400	28 400	855	2 900	14 000	<b>FNTA-1730</b>	FTRA-1730	
18	31	2	8 600	29 700	875	3 050	13 000	<b>FNTA-1831</b>	FTRA-1831	
20	35	2	11 900	47 000	1 220	4 800	12 000	<b>FNTA-2035</b>	FTRA-2035	
25	42	2	14 800	66 000	1 510	6 750	9 500	<b>FNTA-2542</b>	FTRA-2542	
30	47	2	16 500	79 000	1 680	8 100	8 500	<b>FNTA-3047</b>	FTRA-3047	
35	52	2	17 300	88 000	1 770	8 950	8 000	<b>FNTA-3552</b>	FTRA-3552	
40	60	3	26 900	122 000	2 740	12 400	6 700	<b>FNTA-4060</b>	FTRA-4060	
45	65	3	28 700	137 000	2 930	14 000	6 300	<b>FNTA-4565</b>	FTRA-4565	
50	70	3	30 500	152 000	3 100	15 500	5 600	<b>FNTA-5070</b>	FTRA-5070	
55	78	3	37 000	201 000	3 750	20 500	5 300	<b>FNTA-5578</b>	FTRA-5578	
60	85	3	43 000	252 000	4 400	25 700	4 800	<b>FNTA-6085</b>	FTRA-6085	
65	90	3	45 500	274 000	4 600	28 000	4 500	<b>FNTA-6590</b>	FTRA-6590	
70	95	4	59 000	320 000	6 000	33 000	4 300	<b>FNTA-7095</b>	FTRA-7095	
75	100	4	60 000	335 000	6 150	34 500	4 000	<b>FNTA-75100</b>	FTRA-75100	
80	105	4	63 000	365 000	6 450	37 500	3 800	<b>FNTA-80105</b>	FTRA-80105	
85	110	4	64 500	380 000	6 550	39 000	3 600	<b>FNTA-85110</b>	FTRA-85110	
90	120	4	80 000	515 000	8 150	52 500	3 400	<b>FNTA-90120</b>	FTRA-90120	
100	135	4	98 500	695 000	10 000	71 000	3 000	<b>FNTA-100135</b>	FTRA-100135	

Bearing Numbers of Matching Bearing Rings				Roller Contact Surfaces (mm)		Mass (g)	
s=1.5 <sup>0</sup> <sub>-0.08</sub>	s=2.0 <sup>0</sup> <sub>-0.08</sub>	s=2.5 <sup>0</sup> <sub>-0.08</sub>	s=3.0 <sup>0</sup> <sub>-0.08</sub>	Outside Diameter D <sub>e</sub> min	Bore Diameter D <sub>i</sub> max	approx	
						FNTA	FTRA
FTRB-1024	FTRC-1024	—	—	22.0	11.5	2.3	2.9
FTRB-1226	FTRC-1226	—	—	24.0	13.5	3.4	3.3
FTRB-1528	FTRC-1528	FTRD-1528	FTRE-1528	26.0	16.5	3.5	3.5
FTRB-1629	FTRC-1629	FTRD-1629	FTRE-1629	27.0	17.5	3.7	3.6
FTRB-1730	FTRC-1730	FTRD-1730	FTRE-1730	28.0	18.5	3.8	3.8
FTRB-1831	FTRC-1831	FTRD-1831	FTRE-1831	29.0	19.5	4	3.9
FTRB-2035	FTRC-2035	FTRD-2035	FTRE-2035	33.0	21.5	5.4	5.1
FTRB-2542	FTRC-2542	FTRD-2542	FTRE-2542	40.0	26.5	7.7	7
FTRB-3047	FTRC-3047	FTRD-3047	FTRE-3047	45.0	31.5	8.9	7.9
FTRB-3552	FTRC-3552	FTRD-3552	FTRE-3552	50.5	36.5	9.7	9.1
FTRB-4060	FTRC-4060	FTRD-4060	FTRE-4060	57.0	42.0	18	12
FTRB-4565	FTRC-4565	FTRD-4565	FTRE-4565	62.0	47.0	20	13
FTRB-5070	FTRC-5070	FTRD-5070	FTRE-5070	67.0	51.5	22	15
FTRB-5578	FTRC-5578	FTRD-5578	FTRE-5578	75.0	57.0	29	19
FTRB-6085	FTRC-6085	FTRD-6085	FTRE-6085	82.0	61.5	35	22
FTRB-6590	FTRC-6590	FTRD-6590	FTRE-6590	87.5	66.5	38	24
FTRB-7095	FTRC-7095	FTRD-7095	FTRE-7095	92.5	71.5	52	25
FTRB-75100	FTRC-75100	FTRD-75100	FTRE-75100	97.5	76.5	54	27
FTRB-80105	FTRC-80105	FTRD-80105	FTRE-80105	102.5	81.5	58	28
FTRB-85110	FTRC-85110	FTRD-85110	FTRE-85110	107.5	86.5	63	30
FTRB-90120	FTRC-90120	FTRD-90120	FTRE-90120	117.5	91.5	80	38
FTRB-100135	FTRC-100135	FTRD-100135	FTRE-100135	132.5	101.5	105	50

Note (1) For tolerance classes C12 and E11, please refer to ISO 286-1 and 286-2 (ISO system of limits and fits), respectively.

(\*) The tolerance of this bearing bore diameter is +0.025~+0.175mm and outside diameter tolerance is -0.040~-0.370mm

- FCR (Full Complement)
- FCRS (Full Complement, Sealed With Thrust Washer)
- FCJ (With Cage)
- FCJS (Sealed, with Cage and Thrust Washer)
- Outside Diameter 16~90 mm

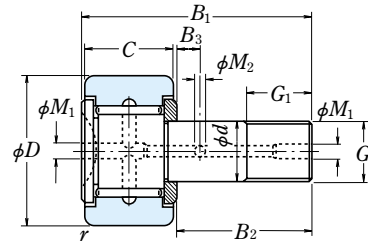

Full Complement

FCR

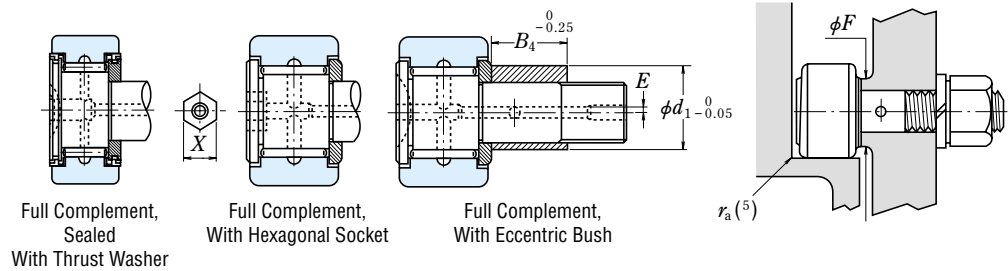

Full Complement, Sealed With Thrust Washer

FCRS

Full Complement, With Hexagonal Socket

FCRB

Full Complement, With Eccentric Bush

FCRE

Boundary Dimensions (mm)			Screw G	Dimensions (mm)							Bearing Numbers	
D	C	d		G <sub>1</sub>	B <sub>1</sub>	B <sub>2</sub>	B <sub>3</sub>	M <sub>2</sub>	M <sub>1</sub>	r <sub>min</sub>	FCR FCJ	FCRS FCJS
16	11	6	M 6×1	8	28	16	—	—	4 <sup>(1)</sup>	0.3	<b>FCR-16</b>	<b>FCRS-16</b>
	11	6	M 6×1	8	28	16	—	—	4 <sup>(1)</sup>	0.3	<b>FCJ-16</b>	<b>FCJS-16</b>
19	11	8	M 8×1.25	10	32	20	—	—	4 <sup>(1)</sup>	0.3	<b>FCR-19</b>	<b>FCRS-19</b>
	11	8	M 8×1.25	10	32	20	—	—	4 <sup>(1)</sup>	0.3	<b>FCJ-19</b>	<b>FCJS-19</b>
22	12	10	M10×1.25	12	36	23	—	—	4 <sup>(1)</sup>	0.3	<b>FCR-22</b>	<b>FCRS-22</b>
	12	10	M10×1.25	12	36	23	—	—	4 <sup>(1)</sup>	0.3	<b>FCJ-22</b>	<b>FCJS-22</b>
26	12	10	M10×1.25	12	36	23	—	—	4 <sup>(1)</sup>	0.3	<b>FCR-26</b>	<b>FCRS-26</b>
	12	10	M10×1.25	12	36	23	—	—	4 <sup>(1)</sup>	0.3	<b>FCJ-26</b>	<b>FCJS-26</b>
30	14	12	M12×1.5	13	40	25	6	3	6	0.6	<b>FCR-30</b>	<b>FCRS-30</b>
	14	12	M12×1.5	13	40	25	6	3	6	0.6	<b>FCJ-30</b>	<b>FCJS-30</b>
32	14	12	M12×1.5	13	40	25	6	3	6	0.6	<b>FCR-32</b>	<b>FCRS-32</b>
	14	12	M12×1.5	13	40	25	6	3	6	0.6	<b>FCJ-32</b>	<b>FCJS-32</b>
35	18	16	M16×1.5	17	52	32.5	8	3	6	0.6	<b>FCR-35</b>	<b>FCRS-35</b>
	18	16	M16×1.5	17	52	32.5	8	3	6	0.6	<b>FCJ-35</b>	<b>FCJS-35</b>
40	20	18	M18×1.5	19	58	36.5	8	3	6	1	<b>FCR-40</b>	<b>FCRS-40</b>
	20	18	M18×1.5	19	58	36.5	8	3	6	1	<b>FCJ-40</b>	<b>FCJS-40</b>
47	24	20	M20×1.5	21	66	40.5	9	4	8	1	<b>FCR-47</b>	<b>FCRS-47</b>
	24	20	M20×1.5	21	66	40.5	9	4	8	1	<b>FCJ-47</b>	<b>FCJS-47</b>
52	24	20	M20×1.5	21	66	40.5	9	4	8	1	<b>FCR-52</b>	<b>FCRS-52</b>
	24	20	M20×1.5	21	66	40.5	9	4	8	1	<b>FCJ-52</b>	<b>FCJS-52</b>
62	29	24	M24×1.5	25	80	49.5	11	4	8	1	<b>FCR-62</b>	<b>FCRS-62</b>
	29	24	M24×1.5	25	80	49.5	11	4	8	1	<b>FCJ-62</b>	<b>FCJS-62</b>
72	29	24	M24×1.5	25	80	49.5	11	4	8	1	<b>FCR-72</b>	<b>FCRS-72</b>
	29	24	M24×1.5	25	80	49.5	11	4	8	1	<b>FCJ-72</b>	<b>FCJS-72</b>
80	35	30	M30×1.5	32	100	63	15	4	8	1	<b>FCR-80</b>	<b>FCRS-80</b>
	35	30	M30×1.5	32	100	63	15	4	8	1	<b>FCJ-80</b>	<b>FCJS-80</b>
85	35	30	M30×1.5	32	100	63	15	4	8	1	<b>FCR-85</b>	<b>FCRS-85</b>
	35	30	M30×1.5	32	100	63	15	4	8	1	<b>FCJ-85</b>	<b>FCJS-85</b>
90	35	30	M30×1.5	32	100	63	15	4	8	1	<b>FCR-90</b>	<b>FCRS-90</b>
	35	30	M30×1.5	32	100	63	15	4	8	1	<b>FCJ-90</b>	<b>FCJS-90</b>

Notes <sup>(1)</sup> Only the head of the stud has on oil hole.

<sup>(2)</sup> Applicable to FCRB only.

Remarks Standard grease is packed in sealed cam followers, but not in cam followers without seals.

Basic Dynamic Load Ratings (N)		Limiting Loads (N)		Limiting Track Loads (N)		Mass (kg)	Eccentric Bush Dimensions <sup>(2)</sup> (mm)			Shoulder Dimensions (mm)	Tightening Torque <sup>(4)</sup> (N·cm) (kgf·cm)		
C <sub>r</sub>	(kgf)	P <sub>max</sub>	(kgf)	(N)	(kgf)	approx	B <sub>4</sub>	d <sub>1</sub>	E	F (min)	(max)	(max)	
5 800	590	2 360	240	3 350	340	0.020	4	8	9	0.5	11	226	23
6 600	670	4 200	425	4 150	425	0.031	4	10	11	0.5	13	550	56
8 550	875	6 550	665	5 300	540	0.047	5	11	13	0.5	15	1 060	108
8 550	875	6 550	665	6 000	610	0.060	5	11	13	0.5	15	1 060	108
12 500	1 280	9 250	945	7 800	795	0.088	6	12	17	1	20	1 450	148
12 500	1 280	9 250	945	8 050	820	0.099	6	12	17	1	20	1 450	148
18 600	1 900	17 000	1 740	11 800	1 200	0.17	10	15.5	22	1	24	4 000	410
20 500	2 090	21 700	2 220	14 300	1 460	0.25	10	17.5	24	1	26	5 950	605
28 200	2 880	26 400	2 690	20 800	2 120	0.39	12	19.5	27	1	31	8 450	860
28 200	2 880	26 400	2 690	22 900	2 340	0.47	12	19.5	27	1	31	8 450	860
40 000	4 100	38 500	3 950	34 000	3 450	0.80	14	24.5	34	1	45	15 200	1 550
40 000	4 100	38 500	3 950	38 000	3 860	1.05	14	24.5	34	1	45	15 200	1 550
60 500	6 200	61 000	6 200	52 000	5 300	1.55	17	31	40	1.5	52	30 500	3 120
60 500	6 200	61 000	6 200	55 500	5 650	1.75	17	31	40	1.5	52	30 500	3 120
60 500	6 200	61 000	6 200	59 000	6 000	1.95	17	31	40	1.5	52	30 500	3 120

Notes <sup>(3)</sup> Applicable to FCRE only.

<sup>(4)</sup> These values are for when the screw is oiled ; they should be approximately doubled when the screw is dry.

<sup>(5)</sup> Should not be greater than r (min).



**FYCR** (Full Complement)  
**FYCRS** (Full Complement, Sealed with Thrust Washer)  
**FYCJ** (With Cage)  
**FYCJS** (Sealed, with Cage and Thrust Washer)  
 Bore Diameter 5~50 mm

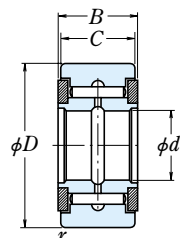

Full Complement

FYCR

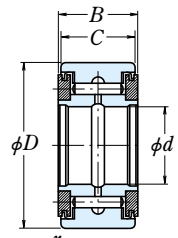

Full Complement, Sealed with Thrust Washer

FYCRS

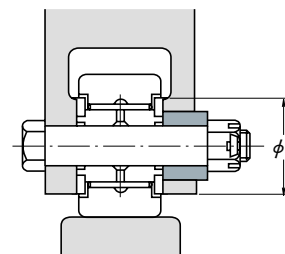

d	Boundary Dimensions (mm)				Basic Load Ratings (N)				Limiting Track Loads (N)	
	D	C	$B^{0-0.38}$	r <sub>min</sub>	C <sub>r</sub>	C <sub>0r</sub>	C <sub>r</sub>	C <sub>0r</sub>	(N)	(kgf)
5	16	11	12	0.3	5 800	8 000	590	815	3 350	340
	16	11	12	0.3	2 830	2 620	288	267	3 350	340
6	19	11	12	0.3	6 550	9 900	665	1 010	4 150	425
	19	11	12	0.3	3 450	3 600	355	365	4 150	425
8	24	14	15	0.3	10 100	15 000	1 030	1 530	6 500	665
	24	14	15	0.3	5 700	6 000	580	610	6 500	665
10	30	14	15	0.6	11 700	18 500	1 190	1 890	7 800	795
	30	14	15	0.6	6 950	8 200	705	835	7 800	795
12	32	14	15	0.6	12 600	21 000	1 280	2 140	8 050	820
	32	14	15	0.6	7 650	9 650	780	985	8 050	820
15	35	18	19	0.6	18 700	29 300	1 910	2 990	11 800	1 200
	35	18	19	0.6	12 200	14 100	1 250	1 440	11 800	1 200
17	40	20	21	0.6	21 100	35 000	2 160	3 600	14 300	1 460
	40	20	21	0.6	13 700	16 700	1 390	1 700	14 300	1 460
20	47	24	25	1	28 900	50 000	2 940	5 100	20 800	2 120
	47	24	25	1	18 200	22 600	1 850	2 310	20 800	2 120
25	52	24	25	1	32 500	60 000	3 300	6 100	22 900	2 340
	52	24	25	1	22 200	31 000	2 270	3 150	22 900	2 340
30	62	28	29	1	47 500	96 000	4 800	9 800	33 000	3 350
	62	28	29	1	31 500	47 000	3 200	4 800	33 000	3 350
35	72	28	29	1	49 500	106 000	5 050	10 800	36 500	3 700
	72	28	29	1	33 000	52 500	3 400	5 350	36 500	3 700
40	80	30	32	1	54 500	126 000	5 600	12 800	43 500	4 450
	80	30	32	1	38 500	67 500	3 950	6 900	43 500	4 450
45	85	30	32	1	57 500	139 000	5 850	14 100	46 500	4 750
	85	30	32	1	40 000	73 000	4 100	7 450	46 500	4 750
50	90	30	32	1	60 500	152 000	6 150	15 500	49 500	5 050
	90	30	32	1	41 500	78 000	4 200	7 950	49 500	5 050

Remarks Standard grease is packed in sealed cam followers, but not in cam followers without seals.

Bearing Numbers		Mass (kg)	Shoulder Dimensions (mm)
FYCR FYCJ	FYCRS FYCJS	approx	F <sub>min</sub>
<b>FYCR-5</b>	<b>FYCRS-5</b>	0.016	10
<b>FYCJ-5</b>	<b>FYCJS-5</b>	0.014	10
<b>FYCR-6</b>	<b>FYCRS-6</b>	0.022	12
<b>FYCJ-6</b>	<b>FYCJS-6</b>	0.020	12
<b>FYCR-8</b>	<b>FYCRS-8</b>	0.044	14
<b>FYCJ-8</b>	<b>FYCJS-8</b>	0.042	14
<b>FYCR-10</b>	<b>FYCRS-10</b>	0.069	17
<b>FYCJ-10</b>	<b>FYCJS-10</b>	0.067	17
<b>FYCR-12</b>	<b>FYCRS-12</b>	0.076	19
<b>FYCJ-12</b>	<b>FYCJS-12</b>	0.074	19
<b>FYCR-15</b>	<b>FYCRS-15</b>	0.105	23
<b>FYCJ-15</b>	<b>FYCJS-15</b>	0.097	23
<b>FYCR-17</b>	<b>FYCRS-17</b>	0.145	25
<b>FYCJ-17</b>	<b>FYCJS-17</b>	0.14	25
<b>FYCR-20</b>	<b>FYCRS-20</b>	0.255	29
<b>FYCJ-20</b>	<b>FYCJS-20</b>	0.245	29
<b>FYCR-25</b>	<b>FYCRS-25</b>	0.285	34
<b>FYCJ-25</b>	<b>FYCJS-25</b>	0.275	34
<b>FYCR-30</b>	<b>FYCRS-30</b>	0.48	51
<b>FYCJ-30</b>	<b>FYCJS-30</b>	0.47	51
<b>FYCR-35</b>	<b>FYCRS-35</b>	0.64	58
<b>FYCJ-35</b>	<b>FYCJS-35</b>	0.635	58
<b>FYCR-40</b>	<b>FYCRS-40</b>	0.88	66
<b>FYCJ-40</b>	<b>FYCJS-40</b>	0.865	66
<b>FYCR-45</b>	<b>FYCRS-45</b>	0.93	72
<b>FYCJ-45</b>	<b>FYCJS-45</b>	0.91	72
<b>FYCR-50</b>	<b>FYCRS-50</b>	0.995	76
<b>FYCJ-50</b>	<b>FYCJS-50</b>	0.965	76

## BALL BEARING UNITS

### SET SCREW TYPE PILLOW BLOCKS CAST HOUSING

UCP2 Shaft Diameter 12~90mm .....Pages B282~B287  
1/2~3 1/2 inch

### SET SCREW TYPE FLANGED UNITS CAST HOUSING

UCF2 Shaft Diameter 12~90mm .....Pages B288~B293  
1/2~3 1/2 inch

UCFL2 Shaft Diameter 12~90mm .....Pages B294~B299  
1/2~3 1/2 inch



## 1. CONSTRUCTION

The NSK bearing unit is a combination of a radial ball bearing, seal, and a housing of high-grade cast iron or pressed steel, which comes in various shapes.

The outer surface of the bearing and the internal surface of the housing are spherical, so that the unit is self-aligning.

The inside construction of the ball bearing for the unit is such that steel balls and retainers of the same type as in series 62 and 63 of the deep groove ball bearing are used. A duplex seal consisting of a combination of an oil-proof synthetic rubber seal and

a slinger is provided on both sides.

Depending on the type, the following methods of fitting to the shaft are employed:

- (1) The inner ring is fastened onto the shaft in two places by set screws.
- (2) The inner ring has a tapered bore and is fitted to the shaft by means of an adapter.
- (3) In the eccentric locking collar system the inner ring is fastened to the shaft by means of eccentrics grooves provided at the side of the inner ring and on the collar.

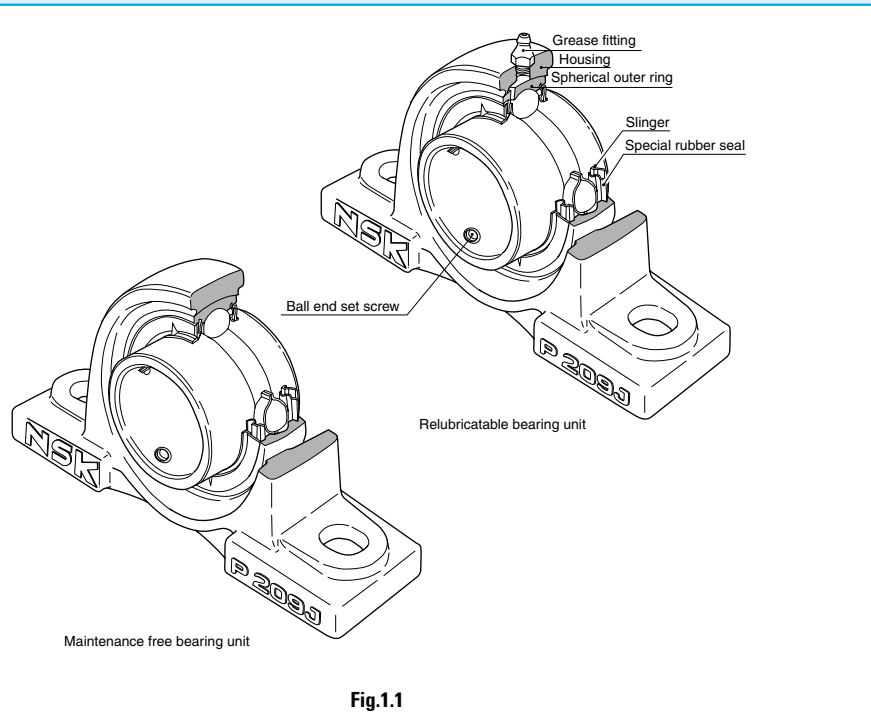

Fig.1.1

## 2. DESIGN FEATURES AND ADVANTAGES

### 2.1 MAINTENANCE FREE TYPE

The NSK Maintenance free bearing unit contains a high-grade lithium-based grease, good for use over a long period, which is ideally suited to sealed-type bearing. Also provided is an excellent sealing device, which prevents any leakage of grease or penetration of dust and water from outside.

It is designed so that the rotation of the shaft causes the sealed-in grease to circulate through the inside space, effectively providing maximum lubrication. The lubrication effect is maintained over a long period with no need for replenishment of grease.

To summarize the advantages of the NSK maintenance free bearing unit:

- (1) As an adequate amount of good quality grease is sealed in at the time of manufacture, there is no need for replenishment. This means savings in terms of time and maintenance costs.
- (2) Since there is no need for any regreasing facilities, such as piping, a more compact design is possible.
- (3) The sealed-in design eliminates the possibility of grease leakage, which could lead to stained products.

### 2.2 RELUBRICATABLE TYPE

The NSK relubricatable type bearing unit has an advantage over other similar, units being so designed as to permit regreasing even in the case of misalignment of  $2^\circ$  to the right or left. The hole through which the grease fitting is mounted usually causes structural weakening of the housing.

However, as a result of extensive testing, in the NSK bearing unit the hole is positioned so as to minimize this adverse effect. In addition, the regreasing groove has been designed to minimize weakening of the housing.

While the NSK maintenance free type bearing unit is satisfactory for use under normal operating conditions in-doors, in the following circumstances it is necessary to use the relubricatable type bearing unit:

- (1) Cases where the temperature of the bearing rises above  $100^\circ\text{C}$ ,  $212^\circ\text{F}$ :  
\* -Normal temperature of up to  $200^\circ\text{C}$ ,  $392^\circ\text{F}$  heat-resistant bearing units.
- (2) Cases where there is excessive dust, but space does not permit using a bearing unit with a cover.
- (3) Cases where the bearing unit is constantly exposed to splashes of water or any other liquid, but space does not permit using a bearing unit with a cover.
- (4) Cases in which the humidity is very high, and the machine in which the bearing unit is used is run only intermittently.

- (5) Cases involving a heavy load of which the  $C_r/P_r$  value is about 10 or below, and the speed is 10 rpm or below, or the movement is oscillatory.
- (6) Cases where the number of revolutions is relatively high and the noise problem has to be considered; for example, when the bearing is used with the fan of an air conditioner.

### 2.3 SPECIAL SEALING FEATURE

#### 2.3.1 STANDARD BEARING UNITS

The sealing device of the ball bearing for the NSK bearing unit is a combination of a heat-resistant and oil-proof synthetic rubber seal and a slinger of an exclusive design.

The seal, which is fixed in the outer ring, is steel-reinforced, and its lip, in contact with the inner ring, is designed to minimize frictional torque.

The slinger is fixed to the inner ring of the bearing with which it rotates. There is a small clearance between its periphery and the outer ring.

There are triangular protrusions on the outside face of the slinger and, as the bearing rotates, these protrusions on the slinger create a flow of air outward from the bearing. In this way, the slinger acts as a fan which-keeps dust and water away from the bearing.

These two types of seals on both sides of the bearing prevent grease leakage, and foreign matter is prevented from entering the bearing from outside.

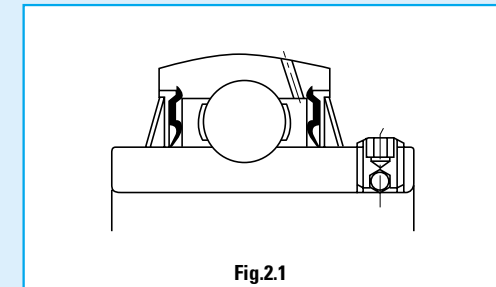

Fig.2.1

**2.3.2 BEARING UNITS WITH COVERS**

The NSK bearing unit with a cover consists of a standard bearing unit and an outside covering for extra protection against dust. Special consideration has been given to its design with respect to dust-proofing.

Sealing devices are provided in both the bearing and the housing, so that units of this type operate satisfactorily even in such adverse environments as flour mills, steel mills, foundries, galvanizing plants and chemical plants, where excessive dust is produced and/or liquids are used. They are also eminently suitable for outdoor environments where dust and rain are inevitable, and in heavy industrial machinery such as construction and transportation equipment.

The rubber seal of the cover contacts with the shaft by its two lips, as shown in Fig. 2.2 and 2.3. By filling the groove between the two lips with grease, an excellent sealing effect is obtained and, at the same time, the contacting portions of the lips are lubricated. Furthermore, the groove is so designed that when the shaft is inclined the rubber seal can move in the radial direction.

When bearing units are exposed to splashes of water rather than to dust, a drain hole (5 to 8 mm, 0.2 to 0.3 inches in diameter) is provided at the bottom of the cover, and grease should be applied to the side of the bearing itself instead of into the cover.

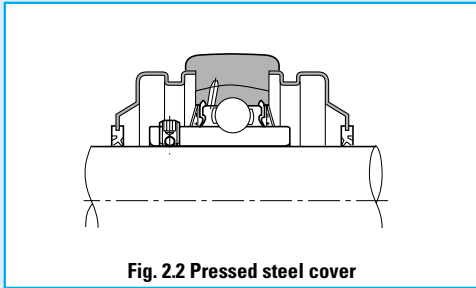

Fig. 2.2 Pressed steel cover

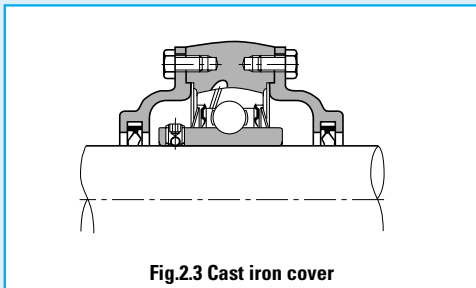

Fig. 2.3 Cast iron cover

**2.4 SECURE FITTING**

Fastening the bearing to the shaft is effected by tightening the ball-end set screw, situated on the inner ring. This is a unique feature which prevents loosening, even if the bearing is subject to intense vibrations and shocks.

**2.5 SELF-ALIGNING**

With the NSK bearing unit, the outer surface of the ball bearing and the inner surface of the housing are spherical, thus this bearing unit has self-aligning characteristic. Any misalignment of axis that arise from poor workmanship on the shaft or errors in fitting will be properly adjusted.

**2.6 HIGHER RATED LOAD CAPACITY**

The bearing used in the unit is of the same internal construction as those in bearing series 62 and 63, and is capable of accommodating axial load as well as radial load, or composite load. The rated load capacity of this bearing is considerably higher than that of the corresponding self-aligning ball bearings used for standard plummer blocks

**2.7 LIGHT WEIGHT YET STRONG HOUSING**

Housings for NSK bearing units come in various shapes. They consist of either high-grade cast iron, one-piece casting, or of precision finished pressed steel, the latter being lighter in weight. In either case, they are practically designed to combine lightness with maximum strength.

**2.8 EASY MOUNTING**

The NSK bearing unit is an integrated unit consisting of a bearing and a housing.

As the bearing is prelubricated at manufacture with the correct amount of high-grade lithium base, it can be mounted on the shaft just as it is. It is sufficient to carry out a short test run after mounting.

**2.9 ACCURATE FITTING OF THE HOUSING**

In order to simplify the fitting of the pillow block and flange type bearing units, the housings are provided with a seat for a dowel pin, which may be utilized as needed.

**2.10 BEARING REPLACEABILITY**

The bearing used in the NSK bearing unit is replaceable. In the event of bearing failure, a new bearing can be fitted to the existing housing.

**3. RECOMMENDED TORQUES FOR TIGHTENING SET SCREWS**

**Table 3.1 Recommended torques for tightening set screws**

A) Metric series, applied to metric bore size.

Designation of the bearings of applicable units			Designation of set screws	Tightening torques N · m (max.)
UC201 to UC205	—	—	M 5×0.8 × 7	3.9
UC206	—	UC305 to UC306	M 6×0.75× 8	4.9
UC207	UCX05	—	M 6×0.75× 8	5.8
UC208 to UC210	—	—	M 8×1 ×10	7.8
UC211	UCX06 to UCX08	UC307	M 8×1 ×10	9.8
UC212	UCX09	—	M10×1.25×12	16.6
UC213 to UC215	—	UC308 to UC309	M10×1.25×12	19.6
UC216	UCX10	—	M10×1.25×12	22.5
—	UCX11 to UCX12	—	M10×1.25×12	24.5
UC217 to UC218	UCX13 to UCX15	UC310 to UC314	M12×1.5 ×13	29.4
—	UCX16 to UCX17	—	M12×1.5 ×13	34.3
—	UCX18	UC315 to UC316	M14×1.5 ×15	34.3
—	UCX20	UC317 to UC319	M16×1.5 ×18	53.9
—	—	UC320 to UC324	M18×1.5 ×20	58.8
—	—	UC326 to UC328	M20×1.5 ×25	78.4

Designation of the bearings of applicable units			Designation of set screws	Tightening torques N · m (max.)
AS201 to 205			M5×0.8 × 7	3.4
AS206			M6×0.75× 8	4.4
AS207			M6×0.75× 8	4.9
AS208			M8×1 ×10	6.8

B) Inch series, applied to inch bore size.

Designation of the bearings for the unit to which torques given are applicable			Designation of set screws	Tightening torques lbf·inch (max.)
UC201 to UC205	—	—	No.10 -32UNF	34
UC206	—	UC305 to UC306	1/4 -28UNF	43
UC207	UCX05	—	1/4 -28UNF	52
UC208 to UC210	—	—	5/16 -24UNF	69
UC211	UCX06 to UCX08	UC307	5/16 -24UNF	86
UC212	UCX09	—	3/8 -24UNF	147
UC213 to UC215	—	UC308 to UC309	3/8 -24UNF	173
UC216	UCX10	—	3/8 -24UNF	199
—	UCX11 to UCX12	—	3/8 -24UNF	216
UC217 to UC218	UCX13 to UCX15	UC310 to UC314	1/2 -20UNF	260
—	UCX16 to UCX17	—	1/2 -20UNF	303
—	UCX18	UC315 to UC316	9/16 -18UNF	303
—	UCX20	UC317 to UC318	5/8 -18UNF	477
—	—	UC320	5/8 -18UNF	520

Designation of the bearings for the unit to which torques given are applicable			Designation of set screws	Tightening torques lbf·inch (max.)
AS201 to 205			No 10-32UNF	30
AS206			1/4 -28UNF	39
AS207			1/4 -28UNF	43
AS208			5/16-24UNF	60

Pillow blocks cast housing  
Set screw type

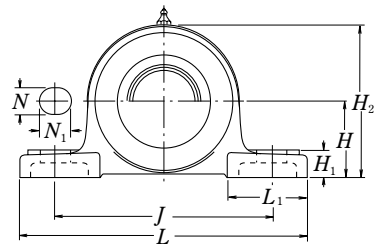
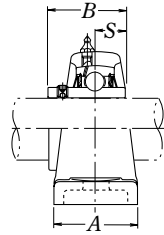
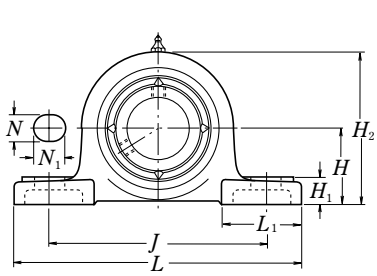

Pressed steel dust cover type  
Open end Z-UCP...D1  
Closed end ZM-UCP...D1

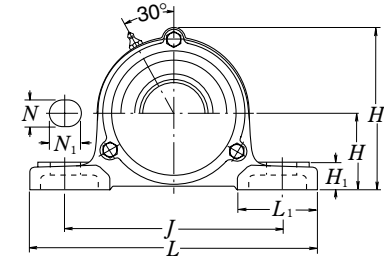
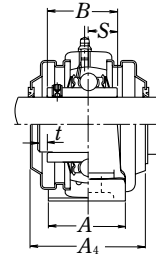

Cast dust cover type  
Open end C-UCP...D1  
Closed end CM-UCP...D1

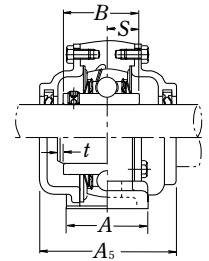

Shaft dia.	Unit number(1)	Nominal dimensions											Bolt size	Bearing number
		mm inch												
mm inch		H	L	J	A	N	N <sub>1</sub>	H <sub>1</sub>	H <sub>2</sub>	L <sub>1</sub>	B	S	mm inch	
12 1/2	UCP201D1 UCP201-008D1	30.2 1 3/16	127 5	95 3 3/4	38 1 1/2	13 1/2	16 5/8	14 9/16	62 2 7/16	42 1 21/32	31 1.2205	12.7 0.500	M10 3/8	UC201D1 UC201-008D1
15 9/16 5/8	UCP202D1 UCP202-009D1 UCP202-010D1	30.2 1 3/16	127 5	95 3 3/4	38 1 1/2	13 1/2	16 5/8	14 9/16	62 2 7/16	42 1 21/32	31 1.2205	12.7 0.500	M10 3/8	UC202D1 UC202-009D1 UC202-010D1
17 1 1/16	UCP203D1 UCP203-011D1	30.2 1 3/16	127 5	95 3 3/4	38 1 1/2	13 1/2	16 5/8	14 9/16	62 2 7/16	42 1 21/32	31 1.2205	12.7 0.500	M10 3/8	UC203D1 UC203-011D1
20 3/4	UCP204D1 UCP204-012D1	33.3 1 5/16	127 5	95 3 3/4	38 1 1/2	13 1/2	16 5/8	14 9/16	65 2 9/16	42 1 21/32	31 1.2205	12.7 0.500	M10 3/8	UC204D1 UC204-012D1
25 1 3/16 7/8 1 5/16	UCP205D1 UCP205-013D1 UCP205-014D1 UCP205-015D1 UCP205-100D1	36.5 1 7/16	140 5 1/2	105 4 1/8	38 1 1/2	13 1/2	16 5/8	15 19/32	71 2 25/32	42 1 21/32	34.1 1.3425	14.3 0.563	M10 3/8	UC205D1 UC205-013D1 UC205-014D1 UC205-015D1 UC205-100D1
30 1 1/16 1 1/8 1 3/16 1 1/4	UCP206D1 UCP206-101D1 UCP206-102D1 UCP206-103D1 UCP206-104D1	42.9 1 11/16	165 6 1/2	121 4 3/4	48 1 7/8	17 21/32	20 25/32	17 21/32	83 3 9/32	54 2 1/8	38.1 1.5000	15.9 0.626	M14 1/2	UC206D1 UC206-101D1 UC206-102D1 UC206-103D1 UC206-104D1
35 1 1/4 1 5/16 1 3/8 1 7/16	UCP207D1 UCP207-104D1 UCP207-105D1 UCP207-106D1 UCP207-107D1	47.6 1 7/8	167 6 9/16	127 5	48 1 7/8	17 21/32	20 25/32	18 23/32	93 3 21/32	54 2 1/8	42.9 1.6890	17.5 0.689	M14 1/2	UC207D1 UC207-104D1 UC207-105D1 UC207-106D1 UC207-107D1
40 1 1/2 1 9/16	UCP208D1 UCP208-108D1 UCP208-109D1	49.2 1 11/16	184 7 1/4	137 5 13/32	54 2 1/8	17 21/32	20 25/32	18 23/32	98 3 27/32	52 2 1/16	49.2 1.9370	19 0.748	M14 1/2	UC208D1 UC208-108D1 UC208-109D1
45 1 5/8 1 11/16 1 3/4	UCP209D1 UCP209-110D1 UCP209-111D1 UCP209-112D1	54 2 1/8	190 7 15/32	146 5 3/4	54 2 1/8	17 21/32	20 25/32	20 25/32	106 4 3/16	60 2 3/8	49.2 1.9370	19 0.748	M14 1/2	UC209D1 UC209-110D1 UC209-111D1 UC209-112D1

Note (1) These numbers indicate relubricatable type. If maintenance free type is needed, please order without suffix "D1".

Housing number	Unit number pressed steel dust cover type	Unit number cast dust cover type	Nominal dimensions				Mass of unit		
			mm inch				kg lb		
			t max.	A <sub>4</sub>	H <sub>3</sub>	A <sub>5</sub>	UCP	Z(ZM)	C(CM)
P203D1	Z(ZM)-UCP201D1	C(CM)-UCP201D1	2	45	67	62	0.7	0.7	1.0
P203D1	Z(ZM)-UCP201-008D1	C(CM)-UCP201-008D1	5/64	125/32	241/64	27/16	1.5	1.5	2.2
P203D1	Z(ZM)-UCP202D1	C(CM)-UCP202D1	2	45	67	62	0.7	0.7	1.0
P203D1	Z(ZM)-UCP202-009D1	C(CM)-UCP202-009D1	5/64	125/32	241/64	27/16	1.5	1.5	2.2
P203D1	Z(ZM)-UCP202-010D1	C(CM)-UCP202-010D1	5/64	125/32	241/64	27/16	1.5	1.5	2.2
P203D1	Z(ZM)-UCP203D1	C(CM)-UCP203D1	2	45	67	62	0.7	0.7	1.0
P203D1	Z(ZM)-UCP203-011D1	C(CM)-UCP203-011D1	5/64	125/32	241/64	27/16	1.5	1.5	2.2
P204D1	Z(ZM)-UCP204D1	C(CM)-UCP204D1	2	45	70	62	0.7	0.7	1.0
P204D1	Z(ZM)-UCP204-012D1	C(CM)-UCP204-012D1	5/64	125/32	23/4	27/16	1.5	1.5	2.2
P205D1	Z(ZM)-UCP205D1	C(CM)-UCP205D1	2	48	76	70	0.8	0.9	1.2
P205D1	Z(ZM)-UCP205-013D1	C(CM)-UCP205-013D1	5/64	129/32	3	23/4	1.8	2.0	2.6
P205D1	Z(ZM)-UCP205-014D1	C(CM)-UCP205-014D1	5/64	129/32	3	23/4	1.8	2.0	2.6
P205D1	Z(ZM)-UCP205-015D1	C(CM)-UCP205-015D1	5/64	129/32	3	23/4	1.8	2.0	2.6
P205D1	Z(ZM)-UCP205-100D1	C(CM)-UCP205-100D1	5/64	129/32	3	23/4	1.8	2.0	2.6
P206D1	Z(ZM)-UCP206D1	C(CM)-UCP206D1	2	53	88	75	1.3	1.4	1.9
P206D1	Z(ZM)-UCP206-101D1	C(CM)-UCP206-101D1	5/64	23/32	315/32	215/16	2.9	3.1	4.2
P206D1	Z(ZM)-UCP206-102D1	C(CM)-UCP206-102D1	5/64	23/32	315/32	215/16	2.9	3.1	4.2
P206D1	Z(ZM)-UCP206-103D1	C(CM)-UCP206-103D1	5/64	23/32	315/32	215/16	2.9	3.1	4.2
P206D1	—	—	—	—	—	—	—	—	—
P207D1	Z(ZM)-UCP207D1	C(CM)-UCP207D1	3	60	99	80	1.6	1.7	2.3
P207D1	Z(ZM)-UCP207-104D1	C(CM)-UCP207-104D1	1/8	23/8	329/32	35/32	3.5	3.7	5.1
P207D1	Z(ZM)-UCP207-105D1	C(CM)-UCP207-105D1	1/8	23/8	329/32	35/32	3.5	3.7	5.1
P207D1	Z(ZM)-UCP207-106D1	C(CM)-UCP207-106D1	1/8	23/8	329/32	35/32	3.5	3.7	5.1
P207D1	—	—	—	—	—	—	—	—	—
P208D1	Z(ZM)-UCP208D1	C(CM)-UCP208D1	3	69	105	90	1.9	2.1	3.2
P208D1	Z(ZM)-UCP208-108D1	C(CM)-UCP208-108D1	1/8	223/32	41/8	317/32	4.2	4.6	7.1
P208D1	Z(ZM)-UCP208-109D1	C(CM)-UCP208-109D1	1/8	223/32	41/8	317/32	4.2	4.6	7.1
P209D1	Z(ZM)-UCP209D1	C(CM)-UCP209D1	3	69	113	95	2.2	2.4	3.5
P209D1	Z(ZM)-UCP209-110D1	C(CM)-UCP209-110D1	1/8	223/32	47/16	33/4	4.9	5.3	7.7
P209D1	Z(ZM)-UCP209-111D1	C(CM)-UCP209-111D1	1/8	223/32	47/16	33/4	4.9	5.3	7.7
P209D1	Z(ZM)-UCP209-112D1	C(CM)-UCP209-112D1	1/8	223/32	47/16	33/4	4.9	5.3	7.7



Pillow blocks cast housing  
Set screw type

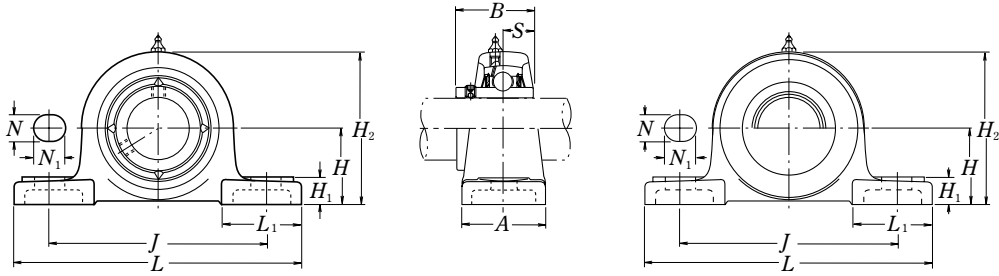

Pressed steel dust cover type  
Open end Z-UCP...D1  
Closed end ZM-UCP...D1

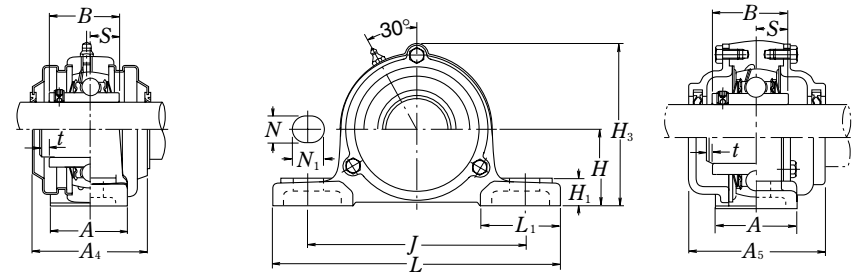

Cast dust cover type  
Open end C-UCP...D1  
Closed end CM-UCP...D1

Shaft dia.	Unit number(1)	Nominal dimensions											Bolt size	Bearing number
		mm inch												
mm inch		H	L	J	A	N	N <sub>1</sub>	H <sub>1</sub>	H <sub>2</sub>	L <sub>1</sub>	B	S	mm inch	
50	UCP210D1	57.2	206	159	60	20	23	21	114	65	51.6	19	M16	UC210D1
1 <sup>13</sup> / <sub>16</sub>	UCP210-113D1													UC210-113D1
1 <sup>7</sup> / <sub>8</sub>	UCP210-114D1	2 <sup>1</sup> / <sub>4</sub>	8 <sup>1</sup> / <sub>8</sub>	6 <sup>1</sup> / <sub>4</sub>	2 <sup>3</sup> / <sub>8</sub>	2 <sup>5</sup> / <sub>32</sub>	2 <sup>9</sup> / <sub>32</sub>	1 <sup>3</sup> / <sub>16</sub>	4 <sup>1</sup> / <sub>2</sub>	2 <sup>9</sup> / <sub>16</sub>	2.0315	0.748	5/8	UC210-114D1
1 <sup>15</sup> / <sub>16</sub>	UCP210-115D1													UC210-115D1
2	UCP210-200D1													UC210-200D1
55	UCP211D1	63.5	219	171	60	20	23	23	126	65	55.6	22.2	M16	UC211D1
2	UCP211-200D1													UC211-200D1
2 <sup>1</sup> / <sub>16</sub>	UCP211-201D1	2 <sup>1</sup> / <sub>2</sub>	8 <sup>5</sup> / <sub>8</sub>	6 <sup>23</sup> / <sub>32</sub>	2 <sup>3</sup> / <sub>8</sub>	2 <sup>5</sup> / <sub>32</sub>	2 <sup>9</sup> / <sub>32</sub>	2 <sup>9</sup> / <sub>32</sub>	4 <sup>3</sup> / <sub>32</sub>	2 <sup>9</sup> / <sub>16</sub>	2.1890	0.874	5/8	UC211-201D1
2 <sup>1</sup> / <sub>8</sub>	UCP211-202D1													UC211-202D1
2 <sup>3</sup> / <sub>16</sub>	UCP211-203D1													UC211-203D1
60	UCP212D1	69.8	241	184	70	20	23	25	138	70	65.1	25.4	M16	UC212D1
2 <sup>1</sup> / <sub>4</sub>	UCP212-204D1													UC212-204D1
2 <sup>5</sup> / <sub>16</sub>	UCP212-205D1	2 <sup>3</sup> / <sub>4</sub>	9 <sup>1</sup> / <sub>2</sub>	7 <sup>1</sup> / <sub>4</sub>	2 <sup>3</sup> / <sub>4</sub>	2 <sup>5</sup> / <sub>32</sub>	2 <sup>9</sup> / <sub>32</sub>	3 <sup>1</sup> / <sub>32</sub>	5 <sup>7</sup> / <sub>16</sub>	2 <sup>3</sup> / <sub>4</sub>	2.5630	1.000	5/8	UC212-205D1
2 <sup>3</sup> / <sub>8</sub>	UCP212-206D1													UC212-206D1
2 <sup>7</sup> / <sub>16</sub>	UCP212-207D1													UC212-207D1
65	UCP213D1	76.2	265	203	70	25	28	27	151	77	65.1	25.4	M20	UC213D1
2 <sup>1</sup> / <sub>2</sub>	UCP213-208D1	3	10 <sup>7</sup> / <sub>16</sub>	8	2 <sup>3</sup> / <sub>4</sub>	3 <sup>1</sup> / <sub>32</sub>	1 <sup>3</sup> / <sub>32</sub>	1 <sup>1</sup> / <sub>16</sub>	5 <sup>15</sup> / <sub>16</sub>	3 <sup>1</sup> / <sub>32</sub>	2.5630	1.000	3/4	UC213-208D1
2 <sup>9</sup> / <sub>16</sub>	UCP213-209D1													UC213-209D1
70	UCP214D1	79.4	266	210	72	25	28	27	157	77	74.6	30.2	M20	UC214D1
2 <sup>5</sup> / <sub>8</sub>	UCP214-210D1													UC214-210D1
2 <sup>11</sup> / <sub>16</sub>	UCP214-211D1	3 <sup>1</sup> / <sub>8</sub>	10 <sup>15</sup> / <sub>32</sub>	8 <sup>9</sup> / <sub>32</sub>	2 <sup>27</sup> / <sub>32</sub>	3 <sup>1</sup> / <sub>32</sub>	1 <sup>3</sup> / <sub>32</sub>	1 <sup>1</sup> / <sub>16</sub>	6 <sup>3</sup> / <sub>16</sub>	3 <sup>1</sup> / <sub>32</sub>	2.9370	1.189	3/4	UC214-211D1
2 <sup>3</sup> / <sub>4</sub>	UCP214-212D1													UC214-212D1
75	UCP215D1	82.6	275	217	74	25	28	28	163	80	77.8	33.3	M20	UC215D1
2 <sup>13</sup> / <sub>16</sub>	UCP215-213D1													UC215-213D1
2 <sup>7</sup> / <sub>8</sub>	UCP215-214D1	3 <sup>1</sup> / <sub>4</sub>	10 <sup>13</sup> / <sub>16</sub>	8 <sup>17</sup> / <sub>32</sub>	2 <sup>29</sup> / <sub>32</sub>	3 <sup>1</sup> / <sub>32</sub>	1 <sup>3</sup> / <sub>32</sub>	1 <sup>3</sup> / <sub>32</sub>	6 <sup>13</sup> / <sub>32</sub>	3 <sup>5</sup> / <sub>32</sub>	3.0630	1.311	3/4	UC215-214D1
2 <sup>15</sup> / <sub>16</sub>	UCP215-215D1													UC215-215D1
3	UCP215-300D1													UC215-300D1
80	UCP216D1	88.9	292	232	78	25	28	30	175	85	82.6	33.3	M20	UC216D1
3 <sup>1</sup> / <sub>16</sub>	UCP216-301D1													UC216-301D1
3 <sup>1</sup> / <sub>8</sub>	UCP216-302D1	3 <sup>1</sup> / <sub>2</sub>	11 <sup>1</sup> / <sub>2</sub>	9 <sup>1</sup> / <sub>8</sub>	3 <sup>1</sup> / <sub>16</sub>	3 <sup>1</sup> / <sub>32</sub>	1 <sup>3</sup> / <sub>16</sub>	6 <sup>7</sup> / <sub>8</sub>	3 <sup>11</sup> / <sub>32</sub>	3.2520	1.311	3/4	UC216-302D1	
3 <sup>3</sup> / <sub>16</sub>	UCP216-303D1													UC216-303D1

Note (1) These numbers indicate relubricatable type. If maintenance free type is needed, please order without suffix "D1".

Housing number	Unit number pressed steel dust cover type	Unit number cast dust cover type	Nominal dimensions				Mass of unit		
			t max.	mm inch			kg lb		
				A <sub>4</sub>	H <sub>3</sub>	A <sub>5</sub>	UCP	Z(ZM)	C(CM)
P210D1	Z(ZM)-UCP210D1	C(CM)-UCP210D1	3	76	119	100	2.6	2.8	4.3
P210D1	Z(ZM)-UCP210-113D1	C(CM)-UCP210-113D1							
P210D1	Z(ZM)-UCP210-114D1	C(CM)-UCP210-114D1	1/8	3	4 <sup>11</sup> / <sub>16</sub>	3 <sup>15</sup> / <sub>16</sub>	5.7	6.2	9.5
P210D1	Z(ZM)-UCP210-115D1	C(CM)-UCP210-115D1							
P210D1	—	—							
P211D1	Z(ZM)-UCP211D1	C(CM)-UCP211D1	4	77	130	100	3.3	3.6	5.2
P211D1	Z(ZM)-UCP211-200D1	C(CM)-UCP211-200D1							
P211D1	Z(ZM)-UCP211-201D1	C(CM)-UCP211-201D1	5/32	3 <sup>1</sup> / <sub>32</sub>	5 <sup>1</sup> / <sub>8</sub>	3 <sup>15</sup> / <sub>16</sub>	7.3	7.9	11
P211D1	Z(ZM)-UCP211-202D1	C(CM)-UCP211-202D1							
P211D1	Z(ZM)-UCP211-203D1	C(CM)-UCP211-203D1							
P212D1	Z(ZM)-UCP212D1	C(CM)-UCP212D1	4	89	143	115	4.6	5.0	6.7
P212D1	Z(ZM)-UCP212-204D1	C(CM)-UCP212-204D1							
P212D1	Z(ZM)-UCP212-205D1	C(CM)-UCP212-205D1	5/33	3 <sup>1</sup> / <sub>2</sub>	5 <sup>5</sup> / <sub>8</sub>	4 <sup>17</sup> / <sub>32</sub>	10	11	15
P212D1	Z(ZM)-UCP212-206D1	C(CM)-UCP212-206D1							
P212D1	—	—							
P213D1	Z(ZM)-UCP213D1	C(CM)-UCP213D1	4	91	155	120	5.9	6.3	7.8
P213D1	Z(ZM)-UCP213-208D1	C(CM)-UCP213-208D1	5/32	3 <sup>19</sup> / <sub>32</sub>	6 <sup>3</sup> / <sub>32</sub>	4 <sup>23</sup> / <sub>32</sub>	13	14	17
P213D1	Z(ZM)-UCP213-209D1	C(CM)-UCP213-209D1							
P214D1	—	C(CM)-UCP214D1	4	—	162	135	6.6	—	9.3
P214D1	—	C(CM)-UCP214-210D1							
P214D1	—	C(CM)-UCP214-211D1	5/32	—	6 <sup>3</sup> / <sub>8</sub>	5 <sup>5</sup> / <sub>16</sub>	15	—	21
P214D1	—	C(CM)-UCP214-212D1							
P215D1	—	C(CM)-UCP215D1	4	—	168	135	7.4	—	11
P215D1	—	C(CM)-UCP215-213D1							
P215D1	—	C(CM)-UCP215-214D1	5/32	—	6 <sup>5</sup> / <sub>8</sub>	5 <sup>5</sup> / <sub>16</sub>	16	—	24
P215D1	—	C(CM)-UCP215-215D1							
P215D1	—	C(CM)-UCP215-300D1							
P216D1	—	C(CM)-UCP216D1	4	—	181	145	9.0	—	13
P216D1	—	C(CM)-UCP216-301D1							
P216D1	—	C(CM)-UCP216-302D1	5/32	—	7 <sup>1</sup> / <sub>8</sub>	5 <sup>23</sup> / <sub>32</sub>	20	—	29
P216D1	—	C(CM)-UCP216-303D1							



Pillow blocks cast housing  
Set screw type

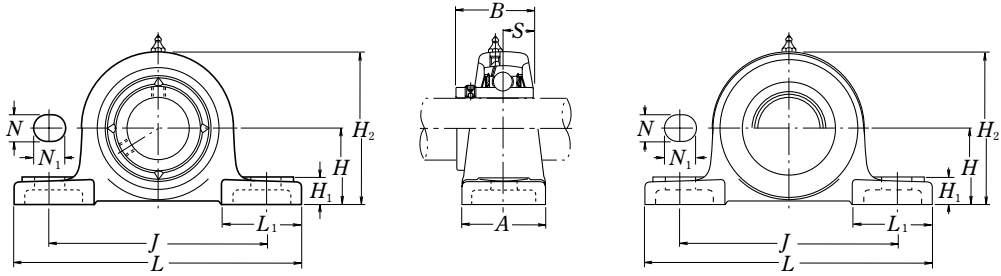

Pressed steel dust cover type  
Open end Z-UCP...D1  
Closed end ZM-UCP...D1

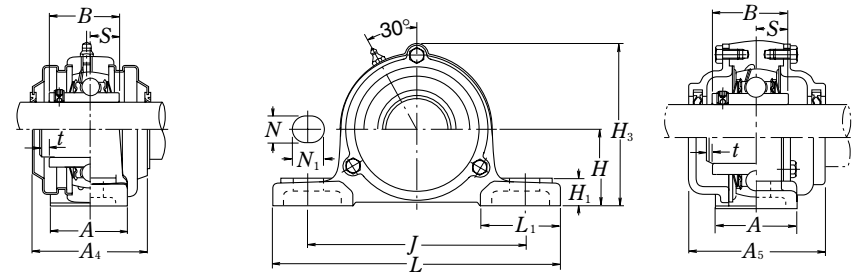

Cast dust cover type  
Open end C-UCP...D1  
Closed end CM-UCP...D1

Shaft dia.	Unit number <sup>(1)</sup>	Nominal dimensions											Bolt size	Bearing number
		mm inch												
mm inch		H	L	J	A	N	N <sub>1</sub>	H <sub>1</sub>	H <sub>2</sub>	L <sub>1</sub>	B	S	mm inch	
85 3 1/4	UCP217D1 UCP217-304D1	95.2	310	247	83	25	28	32	187	85	85.7	34.1	M20	UC217D1 UC217-304D1
35/16 37/16	UCP217-305D1 UCP217-307D1	3 3/4	127/32	923/32	39/32	31/32	13/32	1 1/4	7 3/8	311/32	3.3740	1.343	3/4	UC217-305D1 UC217-307D1
90 3 1/2	UCP218D1 UCP218-308D1	101.6	327	262	88	27	30	33	200	90	96	39.7	M22	UC218D1 UC218-308D1
		4	127/8	105/16	3 15/32	1 1/16	1 3/16	1 5/16	7 7/8	3 17/32	3.7795	1.563	7/8	

**Note** <sup>(1)</sup> These numbers indicate relubricatable type. If maintenance free type is needed, please order without suffix "D1".

Housing number	Unit number pressed steel dust cover type	Unit number cast dust cover type	Nominal dimensions				Mass of unit		
			mm inch				kg lb		
			t max.	A <sub>4</sub>	H <sub>3</sub>	A <sub>5</sub>	UCP	Z(ZM)	C(CM)
P217D1	—	C(CM)-UCP217D1	5	—	191	155	11	—	15
P217D1	—	C(CM)-UCP217-304D1	—	—	—	—	—	—	—
P217D1	—	C(CM)-UCP217-305D1	13/64	—	717/32	63/32	24	—	33
P217D1	—	C(CM)-UCP217-307D1	—	—	—	—	—	—	—
P218D1	—	C(CM)-UCP218D1	5	—	204	165	13	—	18
P218D1	—	C(CM)-UCP218-308D1	13/64	—	8 1/32	6 1/2	29	—	40

Flanged units cast housing  
Set screw type

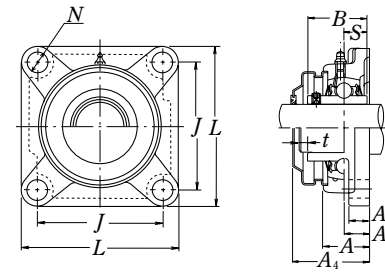
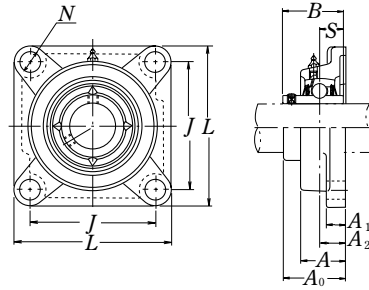

Pressed steel dust cover type  
Open end Z-UCF...D1  
Closed end ZM-UCF...D1

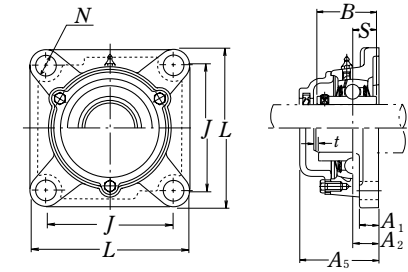

Cast dust cover type  
Open end C-UCF...D1  
Closed end CM-UCF...D1

Shaft dia.	Unit number <sup>(1)</sup>	Nominal dimensions									Bolt size	Bearing number
		mm inch										
mm inch		L	J	A <sub>2</sub>	A <sub>1</sub>	A	N	A <sub>0</sub>	B	S	mm inch	
12 1/2	UCF201D1 UCF201-008D1	86 3 <sup>3</sup> / <sub>8</sub>	64 2 <sup>3</sup> / <sub>8</sub>	15 19/ <sub>32</sub>	11 7/ <sub>16</sub>	25.5 1	12 15/ <sub>32</sub>	33.3 1 <sup>9</sup> / <sub>16</sub>	31 1.2205	12.7 0.500	M10 3/8	UC201D1 UC201-008D1
15 9/ <sub>16</sub> 5/8	UCF202D1 UCF202-009D1 UCF202-010D1	86 3 <sup>3</sup> / <sub>8</sub>	64 2 <sup>3</sup> / <sub>8</sub>	15 19/ <sub>32</sub>	11 7/ <sub>16</sub>	25.5 1	12 15/ <sub>32</sub>	33.3 1 <sup>5</sup> / <sub>16</sub>	31 1.2205	12.7 0.500	M10 3/8	UC202D1 UC202-009D1 UC202-010D1
17 11/ <sub>16</sub>	UCF203D1 UCF203-011D1	86 3 <sup>3</sup> / <sub>8</sub>	64 2 <sup>3</sup> / <sub>8</sub>	15 19/ <sub>32</sub>	11 7/ <sub>16</sub>	25.5 1	12 15/ <sub>32</sub>	33.3 1 <sup>9</sup> / <sub>16</sub>	31 1.2205	12.7 0.500	M10 3/8	UC203D1 UC203-011D1
20 3/4	UCF204D1 UCF204-012D1	86 3 <sup>3</sup> / <sub>8</sub>	64 2 <sup>3</sup> / <sub>8</sub>	15 19/ <sub>32</sub>	11 7/ <sub>16</sub>	25.5 1	12 15/ <sub>32</sub>	33.3 1 <sup>5</sup> / <sub>16</sub>	31 1.2205	12.7 0.500	M10 3/8	UC204D1 UC204-012D1
25 13/ <sub>16</sub> 7/8 15/ <sub>16</sub> 1	UCF205D1 UCF205-013D1 UCF205-014D1 UCF205-015D1 UCF205-100D1	95 3 <sup>3</sup> / <sub>4</sub>	70 2 <sup>3</sup> / <sub>4</sub>	16 5/8	13 1/2	27 11/ <sub>16</sub>	12 15/ <sub>32</sub>	35.8 1 <sup>13</sup> / <sub>32</sub>	34.1 1.3425	14.3 0.563	M10 3/8	UC205D1 UC205-013D1 UC205-014D1 UC205-015D1 UC205-100D1
30 11/ <sub>16</sub> 11/8 13/ <sub>16</sub> 11/4	UCF206D1 UCF206-101D1 UCF206-102D1 UCF206-103D1 UCF206-104D1	108 4 <sup>1</sup> / <sub>4</sub>	83 3 <sup>17</sup> / <sub>64</sub>	18 45/ <sub>64</sub>	13 1/2	31 17/ <sub>32</sub>	12 15/ <sub>32</sub>	40.2 1 <sup>37</sup> / <sub>64</sub>	38.1 1.5000	15.9 0.626	M10 3/8	UC206D1 UC206-101D1 UC206-102D1 UC206-103D1 UC206-104D1
35 11/4 15/ <sub>16</sub> 13/8 17/ <sub>16</sub>	UCF207D1 UCF207-104D1 UCF207-105D1 UCF207-106D1 UCF207-107D1	117 4 <sup>19</sup> / <sub>32</sub>	92 3 <sup>5</sup> / <sub>8</sub>	19 3/4	15 19/ <sub>32</sub>	34 111/ <sub>32</sub>	14 35/ <sub>64</sub>	44.4 1 <sup>13</sup> / <sub>4</sub>	42.9 1.6890	17.5 0.689	M12 7/ <sub>16</sub>	UC207D1 UC207-104D1 UC207-105D1 UC207-106D1 UC207-107D1
40 11/2 19/ <sub>16</sub>	UCF208D1 UCF208-108D1 UCF208-109D1	130 5 <sup>1</sup> / <sub>8</sub>	102 4 <sup>1</sup> / <sub>64</sub>	21 53/ <sub>64</sub>	15 19/ <sub>32</sub>	36 113/ <sub>32</sub>	16 5/8	51.2 2 <sup>1</sup> / <sub>64</sub>	49.2 1.9370	19 0.748	M14 1/2	UC208D1 UC208-108D1 UC208-109D1
45 15/8 111/ <sub>16</sub> 13/4	UCF209D1 UCF209-110D1 UCF209-111D1 UCF209-112D1	137 5 <sup>13</sup> / <sub>32</sub>	105 4 <sup>9</sup> / <sub>64</sub>	22 55/ <sub>64</sub>	16 5/8	38 11/2	16 5/8	52.2 2 <sup>1</sup> / <sub>64</sub>	49.2 1.9370	19 0.748	M14 1/2	UC209D1 UC209-110D1 UC209-111D1 UC209-112D1

Note (1) These numbers indicate relubricatable type. If maintenance free type is needed, please order without suffix "D1".

Housing number	Unit number pressed steel dust cover type	Unit number cast dust cover type	Nominal dimensions			Mass of unit		
			mm inch			kg lb		
			t max.	A <sub>4</sub>	A <sub>5</sub>	UCP	Z(ZM)	C(CM)
F204D1 F204D1	Z(ZM)-UCF201D1 Z(ZM)-UCF201-008D1	C(CM)-UCF201D1 C(CM)-UCF201-008D1	2 5/ <sub>64</sub>	38 1 <sup>1</sup> / <sub>2</sub>	46 1 <sup>13</sup> / <sub>16</sub>	0.7 1.5	0.7 1.5	0.9 2.0
F204D1 F204D1 F204D1	Z(ZM)-UCF202D1 Z(ZM)-UCF202-009D1 Z(ZM)-UCF202-010D1	C(CM)-UCF202D1 C(CM)-UCF202-009D1 C(CM)-UCF202-010D1	2 5/ <sub>64</sub>	38 1 <sup>1</sup> / <sub>2</sub>	46 1 <sup>13</sup> / <sub>16</sub>	0.7 1.5	0.7 1.5	0.9 2.0
F204D1 F204D1	Z(ZM)-UCF203D1 Z(ZM)-UCF203-011D1	C(CM)-UCF203D1 C(CM)-UCF203-011D1	2 5/ <sub>64</sub>	38 1 <sup>1</sup> / <sub>2</sub>	46 1 <sup>13</sup> / <sub>16</sub>	0.6 1.3	0.7 1.5	0.9 2.0
F204D1 F204D1	Z(ZM)-UCF204D1 Z(ZM)-UCF204-012D1	C(CM)-UCF204D1 C(CM)-UCF204-012D1	2 5/ <sub>64</sub>	38 1 <sup>1</sup> / <sub>2</sub>	46 1 <sup>13</sup> / <sub>16</sub>	0.6 1.3	0.7 1.5	0.9 2.0
F205D1 F205D1 F205D1 F205D1 F205D1	Z(ZM)-UCF205D1 Z(ZM)-UCF205-013D1 Z(ZM)-UCF205-014D1 Z(ZM)-UCF205-015D1 Z(ZM)-UCF205-100D1	C(CM)-UCF205D1 C(CM)-UCF205-013D1 C(CM)-UCF205-014D1 C(CM)-UCF205-015D1 C(CM)-UCF205-100D1	2 5/ <sub>64</sub>	40 1 <sup>19</sup> / <sub>32</sub>	51 2	0.8 1.8	0.8 1.8	1.0 2.2
F206D1 F206D1 F206D1 F206D1 F206D1	Z(ZM)-UCF206D1 Z(ZM)-UCF206-101D1 Z(ZM)-UCF206-102D1 Z(ZM)-UCF206-103D1 —	C(CM)-UCF206D1 C(CM)-UCF206-101D1 C(CM)-UCF206-102D1 C(CM)-UCF206-103D1 —	2 5/ <sub>64</sub>	45 1 <sup>3</sup> / <sub>4</sub>	56 2 <sup>7</sup> / <sub>32</sub>	1.0 2.2	1.1 2.4	1.5 3.3
F207D1 F207D1 F207D1 F207D1 F207D1	Z(ZM)-UCF207D1 Z(ZM)-UCF207-104D1 Z(ZM)-UCF207-105D1 Z(ZM)-UCF207-106D1 —	C(CM)-UCF207D1 C(CM)-UCF207-104D1 C(CM)-UCF207-105D1 C(CM)-UCF207-106D1 —	3 1/8	49 1 <sup>15</sup> / <sub>16</sub>	59 2 <sup>5</sup> / <sub>16</sub>	1.4 3.1	1.5 3.3	2.0 4.4
F208D1 F208D1 F208D1	Z(ZM)-UCF208D1 Z(ZM)-UCF208-108D1 Z(ZM)-UCF208-109D1	C(CM)-UCF208D1 C(CM)-UCF208-108D1 C(CM)-UCF208-109D1	3 1/8	56 2 <sup>3</sup> / <sub>16</sub>	66 2 <sup>19</sup> / <sub>32</sub>	1.8 4.0	1.9 4.2	2.6 5.7
F209D1 F209D1 F209D1 F209D1	Z(ZM)-UCF209D1 Z(ZM)-UCF209-110D1 Z(ZM)-UCF209-111D1 Z(ZM)-UCF209-112D1	C(CM)-UCF209D1 C(CM)-UCF209-110D1 C(CM)-UCF209-111D1 C(CM)-UCF209-112D1	3 1/8	57 2 <sup>1</sup> / <sub>4</sub>	70 2 <sup>3</sup> / <sub>4</sub>	2.2 4.9	2.3 5.1	2.8 6.2

Flanged units cast housing  
Set screw type

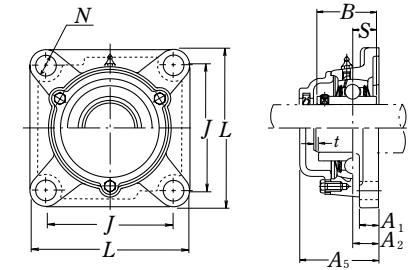
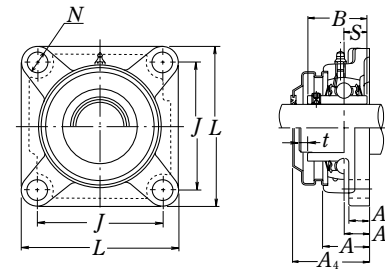
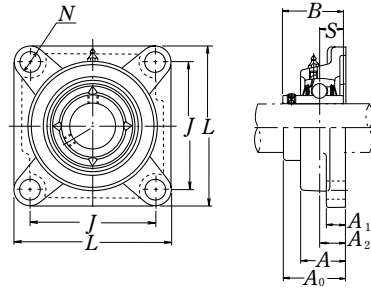

Pressed steel dust cover type  
Open end Z-UCF...D1  
Closed end ZM-UCF...D1

Cast dust cover type  
Open end C-UCF...D1  
Closed end CM-UCF...D1

Shaft dia.	Unit number(1)	Nominal dimensions									Bolt size	Bearing number
		mm inch										
mm inch		L	J	A <sub>2</sub>	A <sub>1</sub>	A	N	A <sub>0</sub>	B	S	mm inch	
50	UCF210D1	143	111	22	16	40	16	54.6	51.6	19	M14	UC210D1
1 <sup>13</sup> / <sub>16</sub>	UCF210-113D1											UC210-113D1
17/8	UCF210-114D1											UC210-114D1
1 <sup>15</sup> / <sub>16</sub>	UCF210-115D1	5 <sup>5</sup> / <sub>8</sub>	4 <sup>3</sup> / <sub>8</sub>	5 <sup>5</sup> / <sub>64</sub>	5/8	1 <sup>9</sup> / <sub>16</sub>	5/8	2 <sup>5</sup> / <sub>32</sub>	2.0315	0.748	1/2	UC210-115D1
2	UCF210-200D1											UC210-200D1
55	UCF211D1	162	130	25	18	43	19	58.4	55.6	22.2	M16	UC211D1
2	UCF211-200D1											UC211-200D1
2 <sup>1</sup> / <sub>16</sub>	UCF211-201D1											UC211-201D1
2 <sup>1</sup> / <sub>8</sub>	UCF211-202D1	6 <sup>3</sup> / <sub>8</sub>	5 <sup>1</sup> / <sub>8</sub>	6 <sup>3</sup> / <sub>64</sub>	2 <sup>3</sup> / <sub>32</sub>	1 <sup>11</sup> / <sub>16</sub>	3/4	2 <sup>19</sup> / <sub>64</sub>	2.1890	0.874	5/8	UC211-202D1
2 <sup>3</sup> / <sub>16</sub>	UCF211-203D1											UC211-203D1
60	UCF212D1	175	143	29	18	48	19	68.7	65.1	25.4	M16	UC212D1
2 <sup>1</sup> / <sub>4</sub>	UCF212-204D1											UC212-204D1
2 <sup>5</sup> / <sub>16</sub>	UCF212-205D1											UC212-205D1
2 <sup>3</sup> / <sub>8</sub>	UCF212-206D1	6 <sup>7</sup> / <sub>8</sub>	5 <sup>5</sup> / <sub>8</sub>	1 <sup>9</sup> / <sub>64</sub>	2 <sup>3</sup> / <sub>32</sub>	1 <sup>7</sup> / <sub>8</sub>	3/4	2 <sup>45</sup> / <sub>64</sub>	2.5630	1.000	5/8	UC212-206D1
2 <sup>7</sup> / <sub>16</sub>	UCF212-207D1											UC212-207D1
65	UCF213D1	187	149	30	22	50	19	69.7	65.1	25.4	M16	UC213D1
2 <sup>1</sup> / <sub>2</sub>	UCF213-208D1											UC213-208D1
2 <sup>9</sup> / <sub>16</sub>	UCF213-209D1	7 <sup>3</sup> / <sub>8</sub>	5 <sup>55</sup> / <sub>64</sub>	1 <sup>3</sup> / <sub>16</sub>	7/8	1 <sup>31</sup> / <sub>32</sub>	3/4	2 <sup>3</sup> / <sub>4</sub>	2.5630	1.000	5/8	UC213-209D1
70	UCF214D1	193	152	31	22	54	19	75.4	74.6	30.2	M16	UC214D1
2 <sup>5</sup> / <sub>8</sub>	UCF214-210D1											UC214-210D1
2 <sup>11</sup> / <sub>16</sub>	UCF214-211D1											UC214-211D1
2 <sup>3</sup> / <sub>4</sub>	UCF214-212D1	7 <sup>19</sup> / <sub>32</sub>	5 <sup>63</sup> / <sub>64</sub>	1 <sup>7</sup> / <sub>32</sub>	7/8	2 <sup>1</sup> / <sub>8</sub>	3/4	2 <sup>31</sup> / <sub>32</sub>	2.9370	1.189	5/8	UC214-212D1
75	UCF215D1	200	159	34	22	56	19	78.5	77.8	33.3	M16	UC215D1
2 <sup>13</sup> / <sub>16</sub>	UCF215-213D1											UC215-213D1
2 <sup>7</sup> / <sub>8</sub>	UCF215-214D1											UC215-214D1
2 <sup>15</sup> / <sub>16</sub>	UCF215-215D1	7 <sup>7</sup> / <sub>8</sub>	6 <sup>17</sup> / <sub>64</sub>	1 <sup>11</sup> / <sub>32</sub>	7/8	2 <sup>7</sup> / <sub>32</sub>	3/4	3 <sup>3</sup> / <sub>32</sub>	3.0630	1.311	5/8	UC215-215D1
3	UCF215-300D1											UC215-300D1
80	UCF216D1	208	165	34	22	58	23	83.3	82.6	33.3	M20	UC216D1
3 <sup>1</sup> / <sub>16</sub>	UCF216-301D1											UC216-301D1
3 <sup>1</sup> / <sub>8</sub>	UCF216-302D1	8 <sup>3</sup> / <sub>16</sub>	6 <sup>1</sup> / <sub>2</sub>	1 <sup>11</sup> / <sub>32</sub>	7/8	2 <sup>9</sup> / <sub>32</sub>	2 <sup>9</sup> / <sub>32</sub>	3 <sup>9</sup> / <sub>32</sub>	3.2520	1.311	3/4	UC216-302D1
3 <sup>3</sup> / <sub>16</sub>	UCF216-303D1											UC216-303D1

Note (1) These numbers indicate relubricatable type. If maintenance free type is needed, please order without suffix "D1".

Housing number	Unit number pressed steel dust cover type	Unit number cast dust cover type	Nominal dimensions			Mass of unit		
			mm inch			kg lb		
			t max.	A <sub>4</sub>	A <sub>5</sub>	UCF	Z(ZM)	C(CM)
F210D1	Z(ZM)-UCF210D1	C(CM)-UCF210D1	3	60	72	2.4	2.5	3.4
F210D1	Z(ZM)-UCF210-113D1	C(CM)-UCF210-113D1						
F210D1	Z(ZM)-UCF210-114D1	C(CM)-UCF210-114D1						
F210D1	Z(ZM)-UCF210-115D1	C(CM)-UCF210-115D1	1/8	2 <sup>3</sup> / <sub>8</sub>	2 <sup>27</sup> / <sub>32</sub>	5.3	5.5	7.5
F210D1	—	—						
F211D1	Z(ZM)-UCF211D1	C(CM)-UCF211D1	4	64	75	3.6	3.7	4.6
F211D1	Z(ZM)-UCF211-200D1	C(CM)-UCF211-200D1						
F211D1	Z(ZM)-UCF211-201D1	C(CM)-UCF211-201D1						
F211D1	Z(ZM)-UCF211-202D1	C(CM)-UCF211-202D1	5/32	2 <sup>1</sup> / <sub>2</sub>	2 <sup>15</sup> / <sub>16</sub>	7.9	8.2	10
F211D1	Z(ZM)-UCF211-203D1	C(CM)-UCF211-203D1						
F212D1	Z(ZM)-UCF212D1	C(CM)-UCF212D1	4	74	86	4.4	4.6	5.9
F212D1	Z(ZM)-UCF212-204D1	C(CM)-UCF212-204D1						
F212D1	Z(ZM)-UCF212-205D1	C(CM)-UCF212-205D1						
F212D1	Z(ZM)-UCF212-206D1	C(CM)-UCF212-206D1	5/32	2 <sup>29</sup> / <sub>32</sub>	3 <sup>3</sup> / <sub>8</sub>	9.7	10	13
F212D1	—	—						
F213D1	Z(ZM)-UCF213D1	C(CM)-UCF213D1	4	76	90	5.5	5.7	7.2
F213D1	Z(ZM)-UCF213-208D1	C(CM)-UCF213-208D1						
F213D1	Z(ZM)-UCF213-209D1	C(CM)-UCF213-209D1	5/32	3	3 <sup>17</sup> / <sub>32</sub>	12	13	16
F214D1	—	C(CM)-UCF214D1	4	—	98	6.1	—	7.8
F214D1	—	C(CM)-UCF214-210D1						
F214D1	—	C(CM)-UCF214-211D1	5/32	—	3 <sup>27</sup> / <sub>32</sub>	13	—	17
F214D1	—	C(CM)-UCF214-212D1						
F215D1	—	C(CM)-UCF215D1	4	—	102	6.9	—	8.6
F215D1	—	C(CM)-UCF215-213D1						
F215D1	—	C(CM)-UCF215-214D1						
F215D1	—	C(CM)-UCF215-215D1	5/32	—	4 <sup>1</sup> / <sub>32</sub>	15	—	19
F215D1	—	C(CM)-UCF215-300D1						
F216D1	—	C(CM)-UCF216D1	4	—	106	8.1	—	10
F216D1	—	C(CM)-UCF216-301D1						
F216D1	—	C(CM)-UCF216-302D1	5/32	—	4 <sup>3</sup> / <sub>16</sub>	18	—	22
F216D1	—	C(CM)-UCF216-303D1						

Flanged units cast housing  
Set screw type

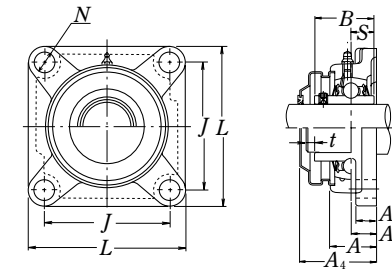
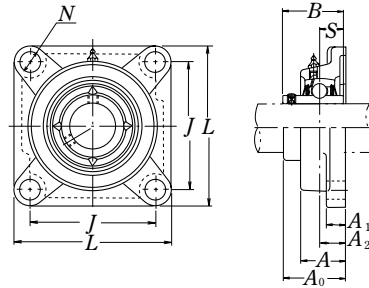

Pressed steel dust cover type  
Open end Z-UCF...D1  
Closed end ZM-UCF...D1

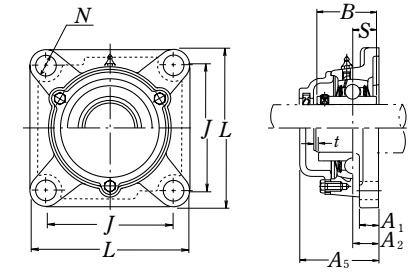

Cast dust cover type  
Open end C-UCF...D1  
Closed end CM-UCF...D1

Shaft dia.	Unit number <sup>(1)</sup>	Nominal dimensions									Bolt size	Bearing number
		mm inch										
mm inch		L	J	A <sub>2</sub>	A <sub>1</sub>	A	N	A <sub>0</sub>	B	S	mm inch	
85 3 1/4	UCF217D1	220	175	36	24	63	23	87.6	85.7	34.1	M20	UC217D1
35/16	UCF217-304D1	82 <sup>1</sup> / <sub>32</sub>	65 <sup>7</sup> / <sub>64</sub>	12 <sup>7</sup> / <sub>64</sub>	15 <sup>1</sup> / <sub>16</sub>	21 <sup>5</sup> / <sub>32</sub>	29 <sup>3</sup> / <sub>32</sub>	32 <sup>9</sup> / <sub>64</sub>	3.3740	1.343	3/4	UC217-304D1
37/16	UCF217-305D1											UC217-305D1
	UCF217-307D1											UC217-307D1
90 3 1/2	UCF218D1	235	187	40	24	68	23	96.3	96	39.7	M20	UC218D1
	UCF218-308D1	91 <sup>1</sup> / <sub>4</sub>	72 <sup>3</sup> / <sub>64</sub>	13 <sup>7</sup> / <sub>64</sub>	15 <sup>1</sup> / <sub>16</sub>	21 <sup>1</sup> / <sub>16</sub>	29 <sup>3</sup> / <sub>32</sub>	35 <sup>1</sup> / <sub>64</sub>	3.7795	1.563	3/4	UC218-308D1

**Note** <sup>(1)</sup> These numbers indicate relubricatable type. If maintenance free type is needed, please order without suffix "D1".

Housing number	Unit number pressed steel dust cover type	Unit number cast dust cover type	Nominal dimensions			Mass of unit		
			mm inch			kg lb		
			t max.	A <sub>4</sub>	A <sub>5</sub>	UCF	Z(ZM)	C(CM)
F217D1	—	<b>C(CM)-UCF217D1</b>	5	—	114	9.3	—	12
F217D1	—	<b>C(CM)-UCF217-304D1</b>	13 <sup>3</sup> / <sub>64</sub>	—	4 <sup>1</sup> / <sub>2</sub>	21	—	26
F217D1	—	<b>C(CM)-UCF217-305D1</b>						
F217D1	—	<b>C(CM)-UCF217-307D1</b>						
F218D1	—	<b>C(CM)-UCF218D1</b>	5	—	122	11	—	15
F218D1	—	<b>C(CM)-UCF218-308D1</b>	13 <sup>3</sup> / <sub>64</sub>	—	4 <sup>13</sup> / <sub>16</sub>	24	—	33

Flanged units cast housing  
Set screw type

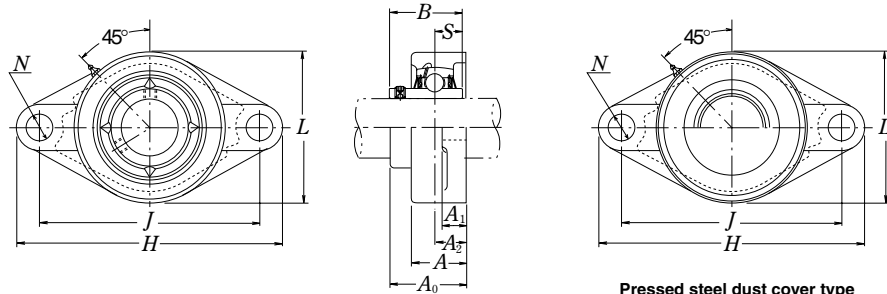

Pressed steel dust cover type  
Open end Z-UCFL...D1  
Closed end ZM-UCFL...D1

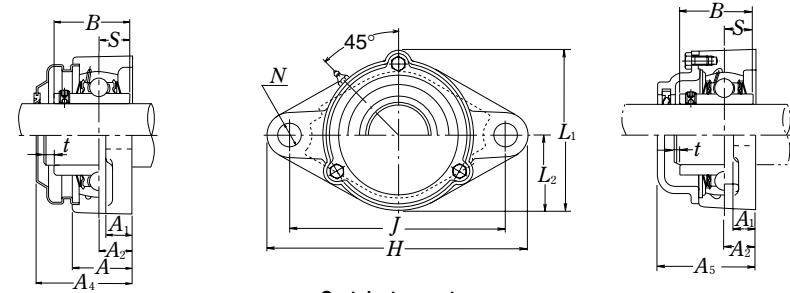

Cast dust cover type  
Open end C-UCFL...D1  
Closed end CM-UCFL...D1

Shaft dia.	Unit number(1)	Nominal dimensions										Bolt size	Bearing number
		mm inch											
		H	J	A <sub>2</sub>	A <sub>1</sub>	A	N	L	A <sub>0</sub>	B	S		
12 1/2	UCFL201D1 UCFL201-008D1	113 47/16	90 35/64	15 19/32	11 7/16	25.5 1	12 15/32	60 23/8	33.3 15/16	31 1.2205	12.7 0.500	M10 3/8	UC201D1 UC201-008D1
15 9/16 5/8	UCFL202D1 UCFL202-009D1 UCFL202-010D1	113 47/16	90 35/64	15 19/32	11 7/16	25.5 1	12 15/32	60 23/8	33.3 15/16	31 1.2205	12.7 0.500	M10 3/8	UC202D1 UC202-009D1 UC202-010D1
17 11/16	UCFL203D1 UCFL203-011D1	113 47/16	90 35/64	15 19/32	11 7/16	25.5 1	12 15/32	60 23/8	33.3 15/16	31 1.2205	12.7 0.500	M10 3/8	UC203D1 UC203-011D1
20 3/4	UCFL204D1 UCFL204-012D1	113 47/16	90 35/64	15 19/32	11 7/16	25.5 1	12 15/32	60 23/8	33.3 15/16	31 1.2205	12.7 0.500	M10 3/8	UC204D1 UC204-012D1
25 13/16 7/8 15/16 1	UCFL205D1 UCFL205-013D1 UCFL205-014D1 UCFL205-015D1 UCFL205-100D1	130 51/8	99 357/64	16 5/8	13 1/2	27 11/16	16 5/8	68 211/16	34.1 113/32	14.3 1.3425	0.563	M14 1/2	UC205D1 UC205-013D1 UC205-014D1 UC205-015D1 UC205-100D1
30 11/16 11/8 13/16 11/4	UCFL206D1 UCFL206-101D1 UCFL206-102D1 UCFL206-103D1 UCFL206-104D1	148 513/16	117 439/64	18 45/64	13 1/2	31 17/32	16 5/8	80 35/32	38.1 137/64	15.9 1.5000	0.626	M14 1/2	UC206D1 UC206-101D1 UC206-102D1 UC206-103D1 UC206-104D1
35 11/4 15/16 13/8 17/16	UCFL207D1 UCFL207-104D1 UCFL207-105D1 UCFL207-106D1 UCFL207-107D1	161 611/32	130 51/8	19 3/4	15 19/32	34 111/32	16 5/8	90 317/32	44.4 13/4	42.9 1.6890	17.5 0.689	M14 1/2	UC207D1 UC207-104D1 UC207-105D1 UC207-106D1 UC207-107D1
40 11/2 19/16	UCFL208D1 UCFL208-108D1 UCFL208-109D1	175 67/8	144 543/64	21 53/64	15 19/32	36 113/32	16 5/8	100 315/16	51.2 21/64	49.2 1.9370	19 0.748	M14 1/2	UC208D1 UC208-108D1 UC208-109D1
45 15/8 111/16 13/4	UCFL209D1 UCFL209-110D1 UCFL209-111D1 UCFL209-112D1	188 713/32	148 553/64	22 55/64	16 5/8	38 11/2	19 3/4	108 41/4	52.2 21/16	49.2 1.9370	19 0.748	M16 5/8	UC209D1 UC209-110D1 UC209-111D1 UC209-112D1

Note (1) These numbers indicate relubricatable type. If maintenance free type is needed, please order without suffix "D1".

Housing number	Unit number pressed steel dust cover type	Unit number cast dust cover type	Nominal dimensions					Mass of unit		
			mm inch					kg lb		
			t max.	A <sub>4</sub>	A <sub>5</sub>	L <sub>1</sub>	L <sub>2</sub>	UCFL	Z(ZM)	C(CM)
FL204D1 FL204D1	Z(ZM)-UCFL201D1 Z(ZM)-UCFL201-008D1	C(CM)-UCFL201D1 C(CM)-UCFL201-008D1	2 5/64	38 11/2	46 113/16	67 25/8	30 13/16	0.6 1.3	0.6 1.3	0.8 0.8
FL204D1 FL204D1 FL204D1	Z(ZM)-UCFL202D1 Z(ZM)-UCFL202-009D1 Z(ZM)-UCFL202-010D1	C(CM)-UCFL202D1 C(CM)-UCFL202-009D1 C(CM)-UCFL202-010D1	2 5/64	38 11/2	46 113/16	67 25/8	30 13/16	0.6 1.3	0.6 1.3	0.8 1.8
FL204D1 FL204D1	Z(ZM)-UCFL203D1 Z(ZM)-UCFL203-011D1	C(CM)-UCFL203D1 C(CM)-UCFL203-011D1	2 5/64	38 11/2	46 113/32	67 25/8	30 13/16	0.5 1.1	0.6 1.3	0.8 1.8
FL204D1 FL204D1	Z(ZM)-UCFL204D1 Z(ZM)-UCFL204-012D1	C(CM)-UCFL204D1 C(CM)-UCFL204-012D1	2 5/64	38 11/2	46 113/16	67 25/8	30 13/16	0.5 1.1	0.6 1.3	0.8 1.8
FL205D1 FL205D1 FL205D1 FL205D1 FL205D1	Z(ZM)-UCFL205D1 Z(ZM)-UCFL205-013D1 Z(ZM)-UCFL205-014D1 Z(ZM)-UCFL205-015D1 Z(ZM)-UCFL205-100D1	C(CM)-UCFL205D1 C(CM)-UCFL205-013D1 C(CM)-UCFL205-014D1 C(CM)-UCFL205-015D1 C(CM)-UCFL205-100D1	2 5/64	40 119/32	51 2	74 229/32	34 111/32	0.6 1.3	0.7 1.5	0.9 2.0
FL206D1 FL206D1 FL206D1 FL206D1 FL206D1	Z(ZM)-UCFL206D1 Z(ZM)-UCFL206-101D1 Z(ZM)-UCFL206-102D1 Z(ZM)-UCFL206-103D1 —	C(CM)-UCFL206D1 C(CM)-UCFL206-101D1 C(CM)-UCFL206-102D1 C(CM)-UCFL206-103D1 —	2 5/64	45 13/4	56 27/32	85 311/32	40 19/16	0.9 2.0	1.0 2.2	1.2 2.6
FL207D1 FL207D1 FL207D1 FL207D1 FL207D1	Z(ZM)-UCFL207D1 Z(ZM)-UCFL207-104D1 Z(ZM)-UCFL207-105D1 Z(ZM)-UCFL207-106D1 —	C(CM)-UCFL207D1 C(CM)-UCFL207-104D1 C(CM)-UCFL207-105D1 C(CM)-UCFL207-106D1 —	3 1/8	49 115/16	59 25/16	97 313/16	45 125/32	1.2 2.6	1.2 2.6	1.8 4.0
FL208D1 FL208D1 FL208D1	Z(ZM)-UCFL208D1 Z(ZM)-UCFL208-108D1 Z(ZM)-UCFL208-109D1	C(CM)-UCFL208D1 C(CM)-UCFL208-108D1 C(CM)-UCFL208-109D1	3 1/8	56 23/16	66 219/32	106 43/16	50 131/32	1.6 3.5	1.6 3.5	2.2 4.9
FL209D1 FL209D1 FL209D1 FL209D1	Z(ZM)-UCFL209D1 Z(ZM)-UCFL209-110D1 Z(ZM)-UCFL209-111D1 Z(ZM)-UCFL209-112D1	C(CM)-UCFL209D1 C(CM)-UCFL209-110D1 C(CM)-UCFL209-111D1 C(CM)-UCFL209-112D1	3 1/8	57 21/4	70 23/4	113 47/16	54 21/8	1.9 4.2	2.0 4.4	2.5 5.5

Flanged units cast housing  
Set screw type

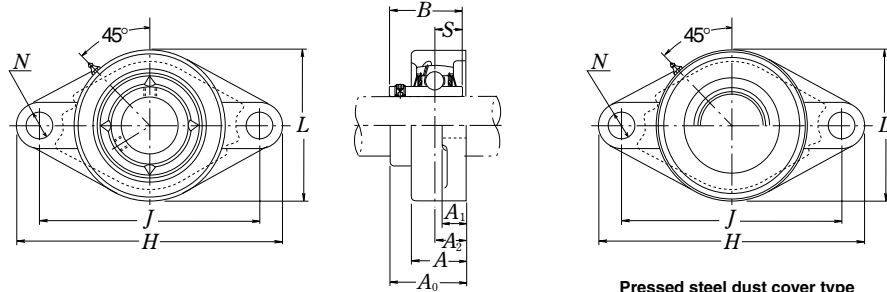

Pressed steel dust cover type  
Open end Z-UCFL...D1  
Closed end ZM-UCFL...D1

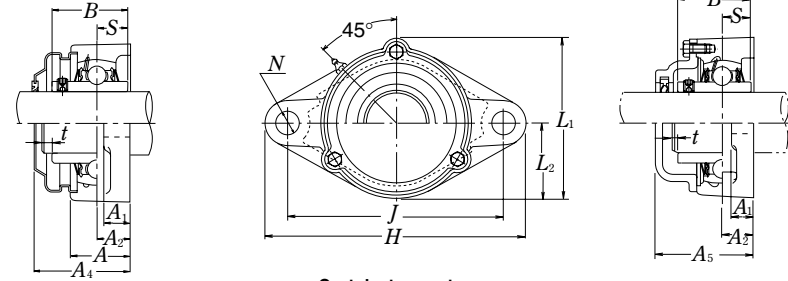

Cast dust cover type  
Open end C-UCFL...D1  
Closed end CM-UCFL...D1

Shaft dia.	Unit number(1)	Nominal dimensions										Bolt size	Bearing number
		mm inch											
mm inch		H	J	A <sub>2</sub>	A <sub>1</sub>	A	N	L	A <sub>0</sub>	B	S	mm inch	
50	UCFL210D1	197	157	22	16	40	19	115	54.6	51.6	19	M16	UC210D1
1 <sup>13</sup> / <sub>16</sub>	UCFL210-113D1												UC210-113D1
17/8	UCFL210-114D1	73/4	63/16	55/64	5/8	19/16	3/4	417/32	2 <sup>5</sup> / <sub>32</sub>	2.0315	0.748	5/8	UC210-114D1
1 <sup>15</sup> / <sub>16</sub>	UCFL210-115D1												UC210-115D1
2	UCFL210-200D1												UC210-200D1
55	UCFL211D1	224	184	25	18	43	19	130	58.4	55.6	22.2	M16	UC211D1
2	UCFL211-200D1												UC211-200D1
2 <sup>1</sup> / <sub>16</sub>	UCFL211-201D1	8 <sup>13</sup> / <sub>16</sub>	7 <sup>1</sup> / <sub>4</sub>	63/64	23/32	11 <sup>1</sup> / <sub>16</sub>	3/4	5 <sup>1</sup> / <sub>8</sub>	2 <sup>19</sup> / <sub>64</sub>	2.1890	0.874	5/8	UC211-201D1
2 <sup>1</sup> / <sub>8</sub>	UCFL211-202D1												UC211-202D1
2 <sup>3</sup> / <sub>16</sub>	UCFL211-203D1												UC211-203D1
60	UCFL212D1	250	202	29	18	48	23	140	68.7	65.1	25.4	M20	UC212D1
2 <sup>1</sup> / <sub>4</sub>	UCFL212-204D1												UC212-204D1
2 <sup>5</sup> / <sub>16</sub>	UCFL212-205D1	9 <sup>27</sup> / <sub>32</sub>	7 <sup>6</sup> / <sub>16</sub>	19/64	23/32	17/8	29/32	5 <sup>1</sup> / <sub>2</sub>	2 <sup>45</sup> / <sub>64</sub>	2.5630	1.000	3/4	UC212-205D1
2 <sup>3</sup> / <sub>8</sub>	UCFL212-206D1												UC212-206D1
2 <sup>7</sup> / <sub>16</sub>	UCFL212-207D1												UC212-207D1
65	UCFL213D1	258	210	30	22	50	23	155	69.7	65.1	25.4	M20	UC213D1
2 <sup>1</sup> / <sub>2</sub>	UCFL213-208D1	10 <sup>5</sup> / <sub>32</sub>	8 <sup>17</sup> / <sub>64</sub>	13/16	7/8	1 <sup>31</sup> / <sub>32</sub>	29/32	6 <sup>3</sup> / <sub>32</sub>	2 <sup>3</sup> / <sub>4</sub>	2.5630	1.000	3/4	UC213-208D1
2 <sup>9</sup> / <sub>16</sub>	UCFL213-209D1												UC213-209D1
70	UCFL214D1	265	216	31	22	54	23	160	75.4	74.6	30.2	M20	UC214D1
2 <sup>5</sup> / <sub>8</sub>	UCFL214-210D1												UC214-210D1
2 <sup>11</sup> / <sub>16</sub>	UCFL214-211D1	10 <sup>7</sup> / <sub>16</sub>	8 <sup>1</sup> / <sub>2</sub>	17/32	7/8	2 <sup>1</sup> / <sub>8</sub>	29/32	6 <sup>5</sup> / <sub>16</sub>	2 <sup>31</sup> / <sub>32</sub>	2.9370	1.189	3/4	UC214-211D1
2 <sup>3</sup> / <sub>4</sub>	UCFL214-212D1												UC214-212D1
75	UCFL215D1	275	225	34	22	56	23	165	78.5	77.8	33.3	M20	UC215D1
2 <sup>13</sup> / <sub>16</sub>	UCFL215-213D1												UC215-213D1
2 <sup>7</sup> / <sub>8</sub>	UCFL215-214D1	10 <sup>13</sup> / <sub>16</sub>	8 <sup>55</sup> / <sub>64</sub>	1 <sup>11</sup> / <sub>32</sub>	7/8	2 <sup>7</sup> / <sub>32</sub>	29/32	6 <sup>1</sup> / <sub>2</sub>	3 <sup>3</sup> / <sub>32</sub>	3.0630	1.311	3/4	UC215-214D1
2 <sup>15</sup> / <sub>16</sub>	UCFL215-215D1												UC215-215D1
3	UCFL215-300D1												UC215-300D1
80	UCFL216D1	290	233	34	22	58	25	180	83.3	82.6	33.3	M22	UC216D1
3 <sup>1</sup> / <sub>16</sub>	UCFL216-301D1												UC216-301D1
3 <sup>1</sup> / <sub>8</sub>	UCFL216-302D1	11 <sup>13</sup> / <sub>32</sub>	9 <sup>11</sup> / <sub>64</sub>	1 <sup>11</sup> / <sub>32</sub>	7/8	2 <sup>9</sup> / <sub>32</sub>	63/64	7 <sup>3</sup> / <sub>32</sub>	3 <sup>9</sup> / <sub>32</sub>	3.2520	1.311	7/8	UC216-302D1
3 <sup>3</sup> / <sub>16</sub>	UCFL216-303D1												UC216-303D1

Note (1) These numbers indicate relubricatable type. If maintenance free type is needed, please order without suffix "D1".

Housing number	Unit number pressed steel dust cover type	Unit number cast dust cover type	Nominal dimensions					Mass of unit		
			t max.	A <sub>4</sub>	A <sub>5</sub>	L <sub>1</sub>	L <sub>2</sub>	UCFL	Z(ZM)	C(CM)
			mm inch					kg lb		
FL210D1	Z(ZM)-UCFL210D1	C(CM)-UCFL210D1	3	60	72	120	58	2.2	2.3	3.0
FL210D1	Z(ZM)-UCFL210-113D1	C(CM)-UCFL210-113D1								
FL210D1	Z(ZM)-UCFL210-114D1	C(CM)-UCFL210-114D1	1/8	23/8	227/32	423/32	29/32	4.9	5.1	6.6
FL210D1	Z(ZM)-UCFL210-115D1	C(CM)-UCFL210-115D1								
FL210D1	—	—								
FL211D1	Z(ZM)-UCFL211D1	C(CM)-UCFL211D1	4	64	75	133	65	3.1	3.2	4.3
FL211D1	Z(ZM)-UCFL211-200D1	C(CM)-UCFL211-200D1								
FL211D1	Z(ZM)-UCFL211-201D1	C(CM)-UCFL211-201D1	5/32	2 <sup>1</sup> / <sub>2</sub>	2 <sup>15</sup> / <sub>16</sub>	5 <sup>1</sup> / <sub>4</sub>	2 <sup>9</sup> / <sub>16</sub>	6.8	7.1	9.5
FL211D1	Z(ZM)-UCFL211-202D1	C(CM)-UCFL211-202D1								
FL211D1	Z(ZM)-UCFL211-203D1	C(CM)-UCFL211-203D1								
FL212D1	Z(ZM)-UCFL212D1	C(CM)-UCFL212D1	4	74	86	144	70	4.0	4.2	5.1
FL212D1	Z(ZM)-UCFL212-204D1	C(CM)-UCFL212-204D1								
FL212D1	Z(ZM)-UCFL212-205D1	C(CM)-UCFL212-205D1	5/32	2 <sup>29</sup> / <sub>32</sub>	33/8	5 <sup>21</sup> / <sub>32</sub>	2 <sup>3</sup> / <sub>4</sub>	8.8	9.3	11
FL212D1	Z(ZM)-UCFL212-206D1	C(CM)-UCFL212-206D1								
FL212D1	—	—								
FL213D1	Z(ZM)-UCFL213D1	C(CM)-UCFL213D1	4	76	90	157	78	5.0	5.2	6.6
FL213D1	Z(ZM)-UCFL213-208D1	C(CM)-UCFL213-208D1	5/32	3	3 <sup>17</sup> / <sub>32</sub>	6 <sup>3</sup> / <sub>16</sub>	3 <sup>1</sup> / <sub>16</sub>	11	11	15
FL213D1	Z(ZM)-UCFL213-209D1	C(CM)-UCFL213-209D1								
FL214D1	—	C(CM)-UCFL214D1	4	—	98	164	80	5.6	—	7.3
FL214D1	—	C(CM)-UCFL214-210D1								
FL214D1	—	C(CM)-UCFL214-211D1	5/32	—	3 <sup>27</sup> / <sub>32</sub>	6 <sup>15</sup> / <sub>32</sub>	3 <sup>5</sup> / <sub>32</sub>	12	—	16
FL214D1	—	C(CM)-UCFL214-212D1								
FL215D1	—	C(CM)-UCFL215D1	4	—	102	169	82	6.2	—	7.8
FL215D1	—	C(CM)-UCFL215-213D1								
FL215D1	—	C(CM)-UCFL215-214D1	5/32	—	4 <sup>1</sup> / <sub>32</sub>	6 <sup>21</sup> / <sub>32</sub>	3 <sup>7</sup> / <sub>32</sub>	14	—	17
FL215D1	—	C(CM)-UCFL215-215D1								
FL215D1	—	C(CM)-UCFL215-300D1								
FL216D1	—	C(CM)-UCFL216D1	4	—	106	183	90	8.2	—	11
FL216D1	—	C(CM)-UCFL216-301D1								
FL216D1	—	C(CM)-UCFL216-302D1	5/32	—	4 <sup>3</sup> / <sub>16</sub>	7 <sup>7</sup> / <sub>32</sub>	3 <sup>17</sup> / <sub>32</sub>	18	—	24
FL216D1	—	C(CM)-UCFL216-303D1								



Flanged units cast housing  
Set screw type

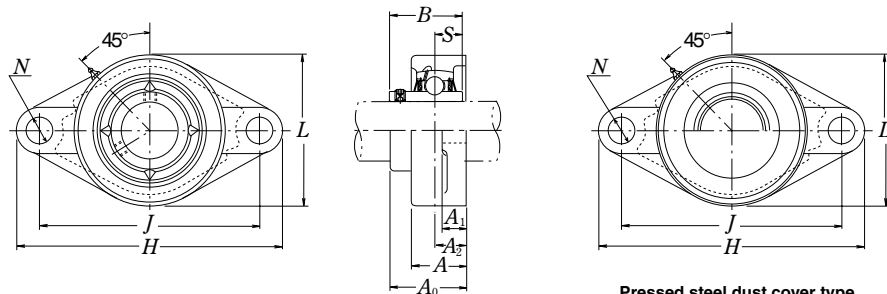

**Pressed steel dust cover type**  
Open end **Z-UCFL...D1**  
Closed end **ZM-UCFL...D1**

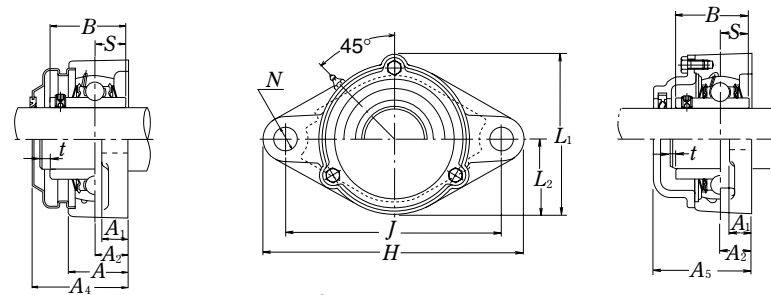

**Cast dust cover type**  
Open end **C-UCFL...D1**  
Closed end **CM-UCFL...D1**

Shaft dia.	Unit number <sup>(1)</sup>	Nominal dimensions										Bolt size	Bearing number
		mm inch											
mm		H	J	A <sub>2</sub>	A <sub>1</sub>	A	N	L	A <sub>0</sub>	B	S	mm	
inch												inch	
85	<b>UCFL217D1</b>	305	248	36	24	63	25	190	87.6	85.7	34.1	M22	UC217D1
31/4	<b>UCFL217-304D1</b>												UC217-304D1
35/16	<b>UCFL217-305D1</b>	12	9 <sup>49</sup> / <sub>64</sub>	1 <sup>27</sup> / <sub>64</sub>	1 <sup>5</sup> / <sub>16</sub>	2 <sup>15</sup> / <sub>32</sub>	6 <sup>3</sup> / <sub>64</sub>	7 <sup>15</sup> / <sub>32</sub>	3 <sup>29</sup> / <sub>64</sub>	3.3740	1.343	7/8	UC217-305D1
37/16	<b>UCFL217-307D1</b>												UC217-307D1
90	<b>UCFL218D1</b>	320	265	40	24	68	25	205	96.3	96	39.7	M22	UC218D1
31/2	<b>UCFL218-308D1</b>	12 <sup>19</sup> / <sub>32</sub>	10 <sup>7</sup> / <sub>16</sub>	1 <sup>37</sup> / <sub>64</sub>	1 <sup>5</sup> / <sub>16</sub>	2 <sup>11</sup> / <sub>16</sub>	6 <sup>3</sup> / <sub>64</sub>	8 <sup>1</sup> / <sub>16</sub>	3 <sup>51</sup> / <sub>64</sub>	3.7795	1.563	7/8	UC218-308D1

**Note** <sup>(1)</sup> These numbers indicate relubricatable type. If maintenance free type is needed, please order without suffix "D1".

Housing number	Unit number pressed steel dust cover type	Unit number cast dust cover type	Nominal dimensions					Mass of unit		
			mm inch					kg lb		
			t max.	A <sub>4</sub>	A <sub>5</sub>	L <sub>1</sub>	L <sub>2</sub>	UCFL	Z(ZM)	C(CM)
FL217D1	—	<b>C(CM)-UCFL217D1</b>	5	—	114	192	95	9.3	—	11
FL217D1		<b>C(CM)-UCFL217-304D1</b>								
FL217D1	—	<b>C(CM)-UCFL217-305D1</b>	1 <sup>3</sup> / <sub>64</sub>	—	4 <sup>1</sup> / <sub>2</sub>	7 <sup>9</sup> / <sub>16</sub>	3 <sup>3</sup> / <sub>4</sub>	21	—	24
FL217D1		<b>C(CM)-UCFL217-307D1</b>								
FL218D1	—	<b>C(CM)-UCFL218D1</b>	5	—	122	205	102	11	—	14
FL218D1	—	<b>C(CM)-UCFL218-308D1</b>	1 <sup>3</sup> / <sub>64</sub>	—	4 <sup>13</sup> / <sub>16</sub>	8 <sup>1</sup> / <sub>16</sub>	4 <sup>1</sup> / <sub>32</sub>	24	—	31

## PLUMMER BLOCKS

**STANDARD TYPE PLUMMER BLOCKS** .....Pages B302~B307  
**LARGE PLUMMER BLOCKS** .....Pages B308~B311  
**DUSTPROOF PLUMMER BLOCKS** .....Pages B312~B313  
**STEPPED-SHAFT TYPE PLUMMER BLOCKS** .....Pages B314~B321

### DESIGN, TYPES AND FEATURES

There are numerous types and sizes of plummer blocks. In this catalog, only the types marked by ■ are shown.

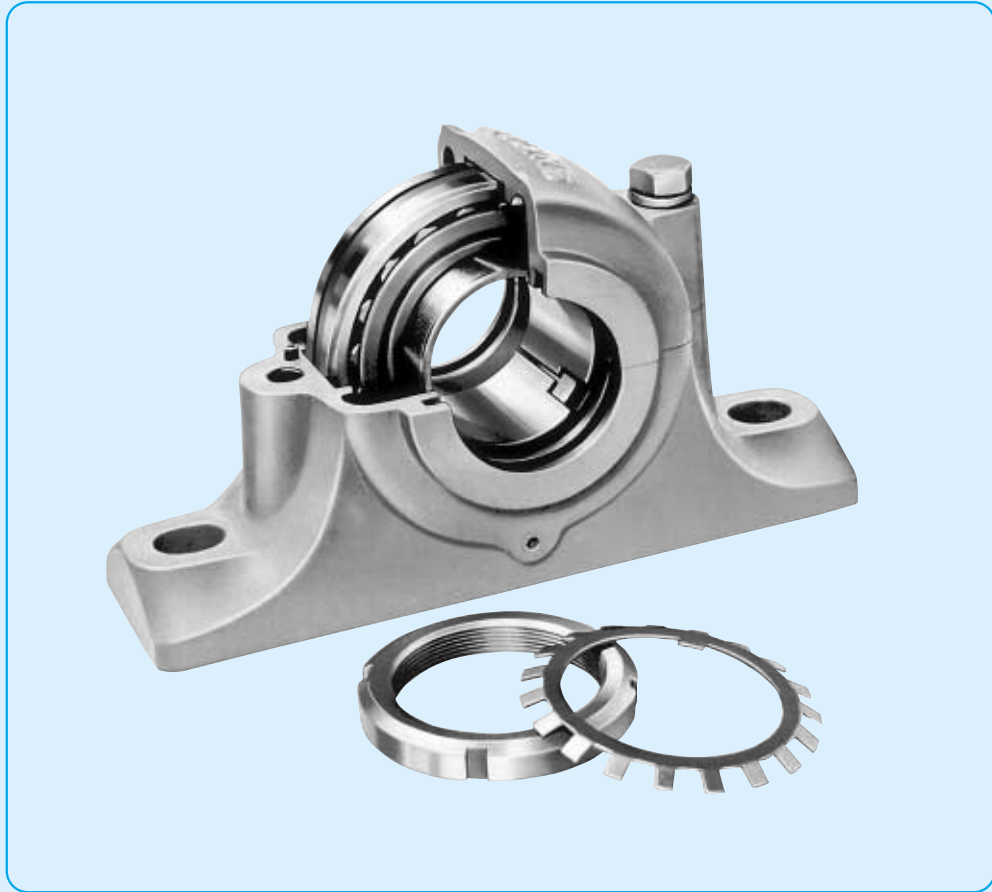

- SN 5
- SN 6
- SN 30
- SN 31
- SN 2
- SN 3
- SN 2C
- SN 3C



These are the most common type. Models SN30 and SN31 are for medium loads. For types SN2C and SN3C, the bore diameters on the two sides are different.

- SN 5B
- SN 6B
- SN 30B
- SN 31B
- SN 2B
- SN 3B
- SN 2BC
- SN 3BC



These have the same dimensions as those of types SN5 and SN6. To increase the bearing box strength, no material is removed from the top or bottom of the base, so mounting holes can be drilled anywhere.

- SG 5



Dustproof plummer blocks have a combination of oil seals, labyrinth seals, and oil groove seals, therefore, they are suitable for environments with much dust and other foreign matter.

- SD 30S
- SD 31S
- SD 5
- SD 6
- SD 2
- SD 3
- SD 2C
- SD 3C

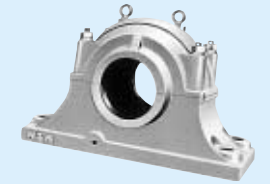

These are large and made for heavy loads. The standard ones have double seals and four mounting bolt holes. For types SD2C and SD3C, the bore diameters on the two sides are different.

- SD31TS
- SD32TS

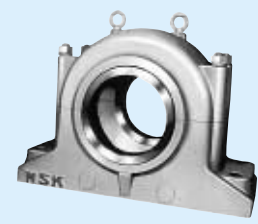

These are provided with labyrinth seals, so they are suitable for high speed applications.

- V · C



Single-piece plummer blocks (integrated type roller bearing unit) have higher rigidity and precision than split type plummer blocks.

SN 5, SN 6 Types  
Shaft Diameter 20~55 mm

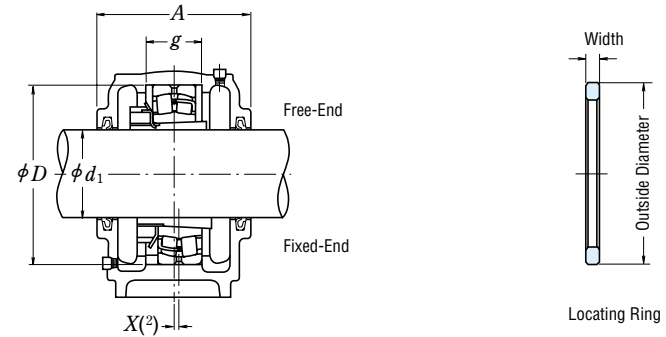
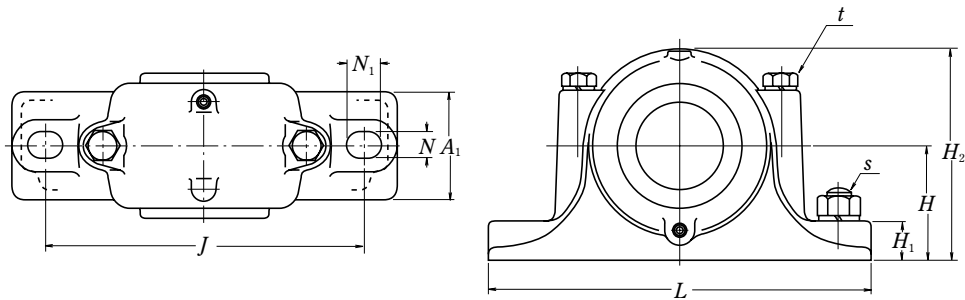

Shaft Diameter (mm) $d_1$	Plummer Block Bearing Box Numbers (1)	Dimensions (mm)											Mass (kg) approx		
		$D_{H8}$	$H_{h13}$	$J$	$N$	$N_1$	$A$	$L$	$A_1$	$H_1$	$H_2$	$g_{H13}$		$t_{nominal}$	$s_{nominal}$
20	SN 505	52	40	130	15	20	67	165	46	22	75	25	M 8	M 12	1.1
	SN 605	62	50	150	15	20	80	185	52	22	90	34	M 8	M 12	1.6
25	SN 506	62	50	150	15	20	77	185	52	22	90	30	M 8	M 12	1.7
	SN 606	72	50	150	15	20	82	185	52	22	95	37	M 10	M 12	1.8
30	SN 507	72	50	150	15	20	82	185	52	22	95	33	M 10	M 12	1.9
	SN 607	80	60	170	15	20	90	205	60	25	110	41	M 10	M 12	2.6
35	SN 508	80	60	170	15	20	85	205	60	25	110	33	M 10	M 12	2.6
	SN 608	90	60	170	15	20	95	205	60	25	115	43	M 10	M 12	2.9
40	SN 509	85	60	170	15	20	85	205	60	25	112	31	M 10	M 12	2.8
	SN 609	100	70	210	18	23	105	255	70	28	130	46	M 12	M 16	4.1
45	SN 510	90	60	170	15	20	90	205	60	25	115	33	M 10	M 12	3.0
	SN 610	110	70	210	18	23	115	255	70	30	135	50	M 12	M 16	4.7
50	SN 511	100	70	210	18	23	95	255	70	28	130	33	M 12	M 16	4.5
	SN 611	120	80	230	18	23	120	275	80	30	150	53	M 12	M 16	5.8
55	SN 512	110	70	210	18	23	105	255	70	30	135	38	M 12	M 16	5.0
	SN 612	130	80	230	18	23	125	280	80	30	155	56	M 12	M 16	6.5

Note (1) Including oil seal.

To place an order for a complete unit, please specify, "Plummer block bearing box+bearing+adapter+locating ring".

Remarks Threads for plugs are R 1/8.

Applicable Parts								Oil Seals (2)
Self-Aligning Ball Bearing Numbers	Basic Dynamic Load Ratings $C_r$ (N)	Spherical Roller Bearing Numbers	Basic Dynamic Load Ratings $C_r$ (N)	Adapter Numbers	Locating Rings Nominal (Outside Dia. xWidth)	Q'ty		
1205 K	12 200	—	—	H 205X	SR 52x 5	2	GS 5	
2205 K	12 400	22205 CKE4	37 500	H 305X	SR 52x 7	1		
1305 K	18 200	21305 CDKE4	43 000	H 305X	SR 62x 8.5	2	GS 5	
2305 K	24 900	—	—	H 2305X	SR 62x 10	1		
1206 K	15 800	—	—	H 206X	SR 62x 7	2	GS 6	
2206 K	15 300	22206 CKE4	50 000	H 306X	SR 62x 10	1		
1306 K	21 400	21306 CDKE4	55 000	H 306X	SR 72x 9	2	GS 6	
2306 K	32 000	—	—	H 2306X	SR 72x 10	1		
1207 K	15 900	—	—	H 207X	SR 72x 8	2	GS 7	
2207 K	21 700	22207 CKE4	69 000	H 307X	SR 72x 10	1		
1307 K	25 300	21307 CDKE4	71 500	H 307X	SR 80x 10	2	GS 7	
2307 K	40 000	—	—	H 2307X	SR 80x 10	1		
1208 K	19 300	—	—	H 208X	SR 80x 7.5	2	GS 8	
2208 K	22 400	22208 EAKE4	90 500	H 308X	SR 80x 10	1		
1308 K	29 800	21308 EAKE4	94 500	H 308X	SR 90x 10	2	GS 8	
2308 K	45 500	22308 EAKE4	136 000	H 2308X	SR 90x 10	1		
1209 K	22 000	—	—	H 209X	SR 85x 6	2	GS 9	
2209 K	23 300	22209 EAKE4	94 500	H 309X	SR 85x 8	1		
1309 K	38 500	21309 EAKE4	119 000	H 309X	SR 100x 10.5	2	GS 9	
2309 K	55 000	22309 EAKE4	166 000	H 2309X	SR 100x 10	1		
1210 K	22 800	—	—	H 210X	SR 90x 6.5	2	GS10	
2210 K	23 400	22210 EAKE4	99 000	H 310X	SR 90x 10	1		
1310 K	43 500	21310 EAKE4	142 000	H 310X	SR 110x 11.5	2	GS10	
2310 K	65 000	22310 EAKE4	197 000	H 2310X	SR 110x 10	1		
1211 K	26 900	—	—	H 211X	SR 100x 6	2	GS11	
2211 K	26 700	22211 EAKE4	119 000	H 311X	SR 100x 8	1		
1311 K	51 500	21311 EAKE4	142 000	H 311X	SR 120x 12	2	GS11	
2311 K	76 500	22311 EAKE4	234 000	H 2311X	SR 120x 10	1		
1212 K	30 500	—	—	H 212X	SR 110x 8	2	GS12	
2212 K	34 000	22212 EAKE4	142 000	H 312X	SR 110x 10	1		
1312 K	57 500	21312 EAKE4	190 000	H 312X	SR 130x 12.5	2	GS12	
2312 K	88 500	22312 EAKE4	271 000	H 2312X	SR 130x 10	1		

Notes (2) The X dimension indicates the offset of the bearing center from the center of the plummer block bearing box. When one locating ring is used, it is 1/2 of the locating ring width, and when two rings are used, it becomes 0.

(3) Applicable to the ZF Type with the same number.

SN 31, SN 5, SN 6 Types  
Shaft Diameter 60~100 mm

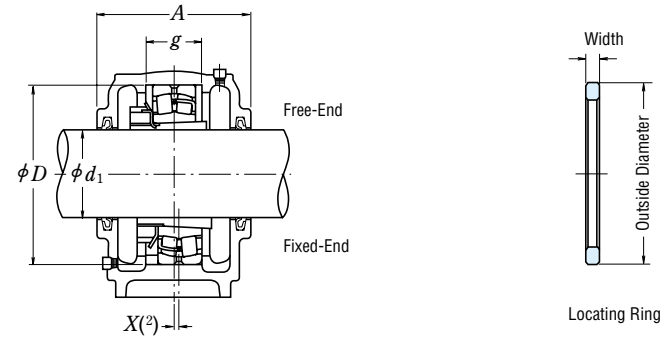
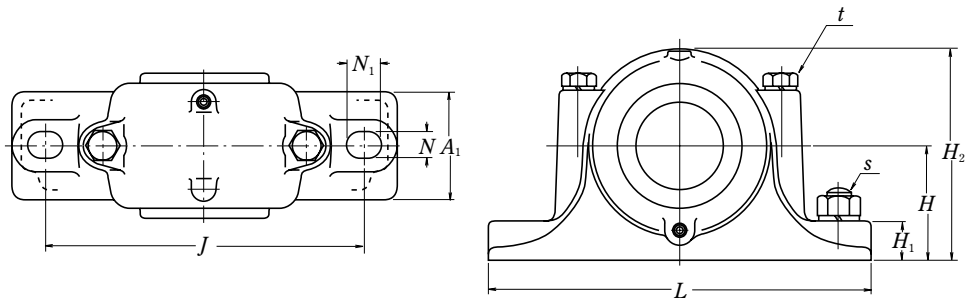

Shaft Diameter (mm) $d_1$	Plummer Block Bearing Box Numbers <sup>(1)</sup>	Dimensions (mm)											Mass (kg) approx		
		D <sub>H8</sub>	H <sub>h13</sub>	J	N	N <sub>1</sub>	A	L	A <sub>1</sub>	H <sub>1</sub>	H <sub>2</sub>	g <sub>H13</sub>		t <sub>nominal</sub>	s <sub>nominal</sub>
60	SN 513	120	80	230	18	23	110	275	80	30	150	43	M12	M16	5.6
	SN 613	140	95	260	22	27	130	315	90	32	175	58	M16	M20	8.7
65	SN 515	130	80	230	18	23	115	280	80	30	155	41	M12	M16	7.0
	SN 615	160	100	290	22	27	140	345	100	35	195	65	M16	M20	11.3
70	SN 516	140	95	260	22	27	120	315	90	32	175	43	M16	M20	9.0
	SN 616	170	112	290	22	27	145	345	100	35	212	68	M16	M20	12.6
75	SN 517	150	95	260	22	27	125	320	90	32	185	46	M16	M20	10
	SN 617	180	112	320	26	32	155	380	110	40	218	70	M20	M24	15
80	SN 518	160	100	290	22	27	145	345	100	35	195	62.4	M16	M20	13
	SN 618	190	112	320	26	32	160	380	110	40	225	74	M20	M24	19
85	SN 519	170	112	290	22	27	140	345	100	35	210	53	M16	M20	15
	SN 619	200	125	350	26	32	170	410	120	45	245	77	M20	M24	22
90	SN 520	180	112	320	26	32	160	380	110	40	218	70.3	M20	M24	18.5
	SN 620	215	140	350	26	32	175	410	120	45	270	83	M20	M24	25
100	SN 3122	180	112	320	26	32	155	380	110	40	218	66	M20	M24	18
	SN 522	200	125	350	26	32	175	410	120	45	240	80	M20	M24	20
	SN 622	240	150	390	28	36	190	450	130	50	300	90	M24	M24	32

Note <sup>(1)</sup> Including oil seal.

To place an order for a complete unit, please specify, "Plummer block bearing box+bearing+adapter+locating ring".

- Remarks 1. The threads for plugs are R 1/8 for SN 616 and SN 519 or under and R 1/4 for SN 617, SN 520, SN 3122, and over.  
2. SN 620 and SN 622 are provided with eye bolts.

Applicable Parts							Oil Seals <sup>(2)</sup>
Self-Aligning Ball Bearing Numbers	Basic Dynamic Load Ratings C <sub>r</sub> (N)	Spherical Roller Bearing Numbers	Basic Dynamic Load Ratings C <sub>r</sub> (N)	Adapter Numbers	Locating Rings (Nominal Outside Dia. x Width)	Q'ty	
1213 K	31 000	—	—	H 213X	SR 120x10	2	GS13
2213 K	43 500	22213 EAKE4	177 000	H 313X	SR 120x12	1	
1313 K	62 500	21313 EAKE4	212 000	H 313X	SR 140x12.5	2	GS13
2313 K	97 000	22313 EAKE4	300 000	H 2313X	SR 140x10	1	
1215 K	39 000	—	—	H 215X	SR 130x 8	2	GS15
2215 K	44 500	22215 EAKE4	190 000	H 315X	SR 130x10	1	
1315 K	80 000	21315 EAKE4	250 000	H 315X	SR 160x14	2	GS15
2315 K	125 000	22315 EAKE4	390 000	H 2315X	SR 160x10	1	
1216 K	40 000	—	—	H 216X	SR 140x 8.5	2	GS16
2216 K	49 000	22216 EAKE4	212 000	H 316X	SR 140x10	1	
1316 K	89 000	21316 EAKE4	284 000	H 316X	SR 170x14.5	2	GS16
2316 K	130 000	22316 EAKE4	435 000	H 2316X	SR 170x10	1	
1217 K	49 500	—	—	H 217X	SR 150x 9	2	GS17
2217 K	58 500	22217 EAKE4	250 000	H 317X	SR 150x10	1	
1317 K	98 500	21317 EAKE4	289 000	H 317X	SR 180x14.5	2	GS17
2317 K	142 000	22317 EAKE4	480 000	H 2317X	SR 180x10	1	
1218 K	57 500	—	—	H 218X	SR 160x16.2	2	GS18
2218 K	70 500	22218 EAKE4	289 000	H 318X	SR 160x11.2	2	
—	—	23218 CKE4	340 000	H 2318X	SR 160x10	1	
1318 K	117 000	21318 EAKE4	330 000	H 318X	SR 190x15.5	2	GS18
2318 K	154 000	22318 EAKE4	535 000	H 2318X	SR 190x10	1	
1219 K	64 000	—	—	H 219X	SR 170x10.5	2	GS19
2219 K	84 000	22219 EAKE4	330 000	H 319X	SR 170x10	1	
1319 K	129 000	21319 CKE4	345 000	H 319X	SR 200x16	2	GS19
2319 K	161 000	22319 EAKE4	590 000	H 2319X	SR 200x10	1	
1220 K	69 500	—	—	H 220X	SR 180x18.1	2	GS20
2220 K	94 500	22220 EAKE4	365 000	H 320X	SR 180x12.1	2	
—	—	23220 CKE4	420 000	H 2320X	SR 180x10	1	
1320 K	140 000	21320 CKE4	395 000	H 320X	SR 215x18	2	GS20
2320 K	187 000	22320 EAKE4	690 000	H 2320X	SR 215x10	1	
—	—	23122 CKE4	385 000	H 3122X	SR 180x10	1	GS22
1222 K	87 000	—	—	H 222X	SR 200x21	2	GS22
2222 K	122 000	22222 EAKE4	485 000	H 322X	SR 200x13.5	2	
—	—	23222 CKE4	515 000	H 2322X	SR 200x10	1	
1322 K	161 000	21322 CAKE4	450 000	H 322X	SR 240x20	2	GS22
2322 K	211 000	22322 EAKE4	825 000	H 2322X	SR 240x10	1	

Notes <sup>(2)</sup> The X dimension indicates the offset of the bearing center from the center of the plummer block bearing box. When one locating ring is used, it is 1/2 of the locating ring width, and when two rings are used, it becomes 0.

<sup>(3)</sup> Applicable to the ZF Type with the same number.

# STANDARD TYPE PLUMMER BLOCKS

SN 30, SN 31, SN 5, SN 6 Types  
Shaft Diameter 110~140 mm

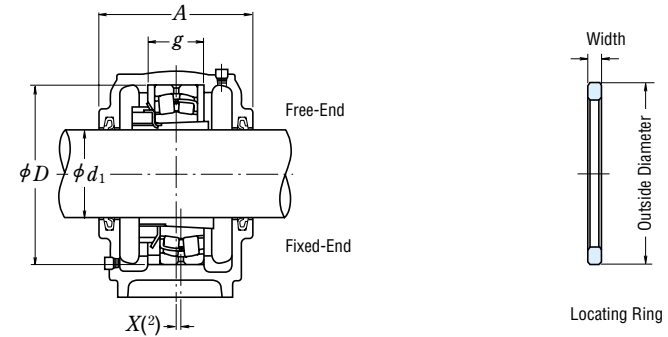
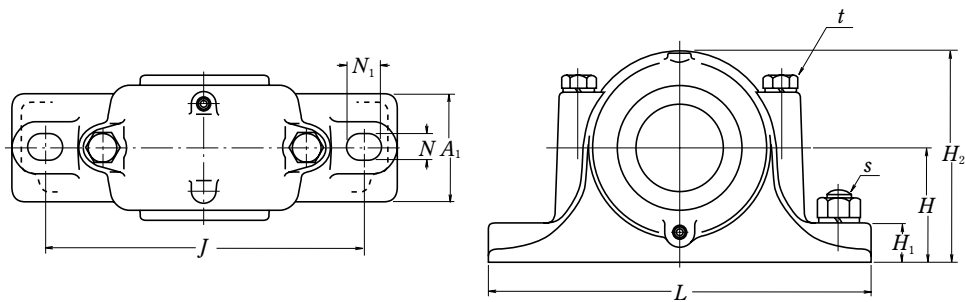

Shaft Diameter (mm) $d_1$	Plummer Block Bearing Box Numbers <sup>(1)</sup>	Dimensions (mm)											Mass (kg) approx			
		$D_{H8}$	$H_{h13}$	$J$	$N$	$N_1$	$A$	$L$	$A_1$	$H_1$	$H_2$	$g_{H13}$		$t_{nominal}$	$s_{nominal}$	
110	SN 3024	180	112	320	26	32	150	380	110	40	218	56	M20	M24	16	
	SN 3124	200	125	350	26	32	165	410	120	45	245	72	M20	M24	20	
	SN 524	215	140	350	26	32	185	410	120	45	270	86	M20	M24	24.5	
	SN 624	260	160	450	33	42	200	530	160	60	320	96	M24	M30	48	
115	SN 3026	200	125	350	26	32	160	410	120	45	240	62	M20	M24	19	
	SN 3126	210	140	350	26	32	170	410	120	45	270	74	M20	M24	26	
	SN 526	230	150	380	28	36	190	445	130	50	290	90	M24	M24	30	
	SN 626	280	170	470	33	42	210	550	160	60	340	103	M24	M30	56	
125	SN 3028	210	140	350	26	32	170	410	120	45	270	63	M20	M24	25	
	SN 3128	225	150	380	28	36	180	445	130	50	290	78	M24	M24	32	
	SN 528	250	150	420	33	42	205	500	150	50	305	98	M24	M30	38	
		SN 628	300	180	520	35	45	235	610	170	65	365	112	M30	M30	72
		SN 3030	225	150	380	28	36	175	445	130	50	290	66	M24	M24	29
135	SN 3130	250	150	420	33	42	200	500	150	50	305	90	M24	M30	38	
	SN 530	270	160	450	33	42	220	530	160	60	325	106	M24	M30	46	
	SN 630	320	190	560	35	45	245	650	180	65	385	118	M30	M30	98	
140	SN 3032	240	150	390	28	36	190	450	130	50	300	70	M24	M24	32	
	SN 3132	270	160	450	33	42	215	530	160	60	325	96	M24	M30	48	
	SN 532	290	170	470	33	42	235	550	160	60	345	114	M24	M30	50	
	SN 632	340	200	580	42	50	255	680	190	70	405	124	M30	M36	115	

Applicable Parts							Oil Seals <sup>(2)</sup>
Self-Aligning Ball Bearing Numbers	Basic Dynamic Load Ratings $C_r$ (N)	Spherical Roller Bearing Numbers	Basic Dynamic Load Ratings $C_r$ (N)	Adapter Numbers	Locating Rings Nominal (Outside Dia. x Width)	Q'ty	
—	—	23024 CDKE4	315 000	H 3024	SR 180x10	1	GS24
—	—	23124 CKE4	465 000	H 3124	SR 200x10	1	GS24
—	—	22224 EAKE4	550 000	H 3124	SR 215x14	2	GS24
—	—	23224 CKE4	630 000	H 2324	SR 215x10	1	GS24
—	—	22324 EAKE4	955 000	H 2324	SR 260x10	1	GS24
—	—	23026 CDKE4	400 000	H 3026	SR 200x10	1	GS26
—	—	23126 CKE4	505 000	H 3126	SR 210x10	1	GS26
—	—	22226 EAKE4	655 000	H 3126	SR 230x13	2	GS26
—	—	23226 CKE4	700 000	H 2326	SR 230x10	1	GS26
—	—	22326 EAKE4	995 000	H 2326	SR 280x10	1	GS26
—	—	23028 CDKE4	420 000	H 3028	SR 210x10	1	GS28
—	—	23128 CKE4	580 000	H 3128	SR 225x10	1	GS28
—	—	22228 CDKE4	645 000	H 3128	SR 250x15	2	GS28
—	—	23228 CKE4	835 000	H 2328	SR 250x10	1	GS28
—	—	22328 EAKE4	1 160 000	H 2328	SR 300x10	1	GS28
—	—	23030 CDKE4	470 000	H 3030	SR 225x10	1	GS30
—	—	23130 CKE4	725 000	H 3130	SR 250x10	1	GS30
—	—	22230 CDKE4	765 000	H 3130	SR 270x16.5	2	GS30
—	—	23230 CKE4	975 000	H 2330	SR 270x10	1	GS30
—	—	22330 EAKE4	1 220 000	H 2330	SR 320x10	1	GS30
—	—	23032 CDKE4	540 000	H 3032	SR 240x10	1	GS32
—	—	23132 CKE4	855 000	H 3132	SR 270x10	1	GS32
—	—	22232 CDKE4	910 000	H 3132	SR 290x17	2	GS32
—	—	23232 CKE4	1 100 000	H 2332	SR 290x10	1	GS32
—	—	22332 EAKE4	1 360 000	H 2332	SR 340x10	1	GS32

**Note** <sup>(1)</sup> Including oil seal.  
To place an order for a complete unit, please specify, "Plummer block bearing box+bearing+adapter+locating ring".  
**Remarks** 1. The threads for plugs are R 1/4.  
2. The bearing boxes for SN 524, SN 624, SN 3126, SN 3028, and over are provided with eye bolts.

**Notes** <sup>(2)</sup> The X dimension indicates the offset of the bearing center from the center of the plummer block bearing box. When one locating ring is used, it is 1/2 of the locating ring width, and when two rings are used, it becomes 0.  
<sup>(3)</sup> Applicable to the ZF Type with the same number.

# LARGE-SIZE PLUMMER BLOCKS

SD 30 S, SD 31 S, SD 5, SD 6 Types  
Shaft Diameter 150~260 mm

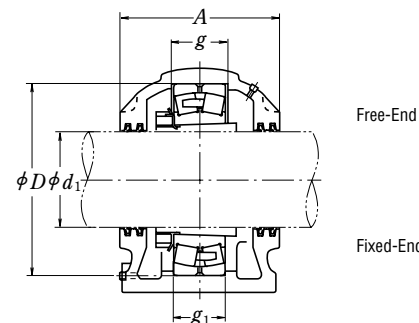
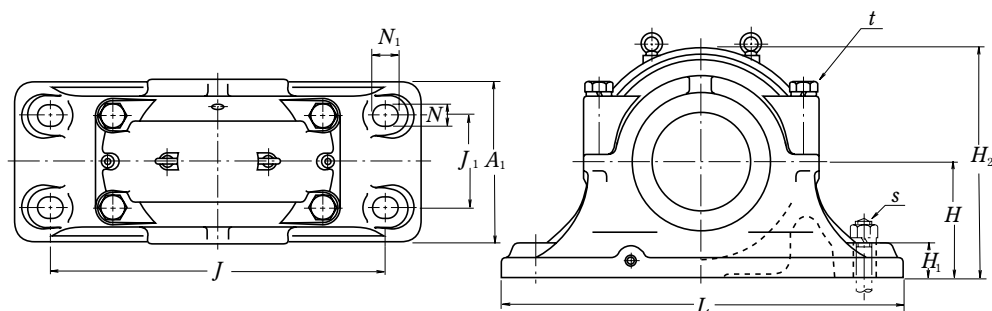

Shaft Diameter (mm) $d_1$	Plummer Block Bearing Box Numbers <sup>(1)</sup>		Dimensions (mm)										
	Free-End	Fixed-End	$D_{H8}$	$H_{h13}$	$J$	$N$	$N_1$	$A$	$L$	$A_1$	$H_1$	$H_2$	$J_1$
150	SD 3034 S	SD 3034 SG	260	160	450	36	46	230	540	200	50	315	110
	SD 3134 S	SD 3134 SG	280	170	470	36	46	250	560	220	50	335	120
	SD 534	SD 534 G	310	180	510	36	46	270	620	250	60	360	140
	SD 634	SD 634 G	360	210	610	36	46	300	740	290	65	420	170
160	SD 3036 S	SD 3036 SG	280	170	470	36	46	250	560	220	50	335	120
	SD 3136 S	SD 3136 SG	300	180	520	36	46	270	630	250	55	355	140
	SD 536	SD 536 G	320	190	540	36	46	280	650	260	60	380	150
	SD 636	SD 636 G	380	225	640	43	59	320	780	310	70	450	180
170	SD 3038 S	SD 3038 SG	290	170	470	36	46	250	560	220	50	340	120
	SD 3138 S	SD 3138 SG	320	190	560	36	46	290	680	270	55	385	140
	SD 538	SD 538 G	340	200	570	36	46	290	700	280	65	400	160
	SD 638	SD 638 G	400	240	680	43	59	330	820	320	70	475	190
180	SD 3040 S	SD 3040 SG	310	180	510	36	46	270	620	250	60	360	140
	SD 3140 S	SD 3140 SG	340	200	570	36	46	310	700	280	65	400	160
	SD 540	SD 540 G	360	210	610	36	46	300	740	290	65	420	170
	SD 640	SD 640 G	420	250	710	43	59	350	860	340	85	500	200
200	SD 3044 S	SD 3044 SG	340	200	570	36	46	290	700	280	65	400	160
	SD 3144 S	SD 3144 SG	370	225	640	43	59	320	780	310	70	445	180
	SD 544	SD 544 G	400	240	680	43	59	330	820	320	70	475	190
	SD 644	SD 644 G	460	280	770	43	59	360	920	350	85	550	210
220	SD 3048 S	SD 3048 SG	360	210	610	36	46	300	740	290	65	420	170
	SD 3148 S	SD 3148 SG	400	240	680	43	59	330	820	320	70	475	190
	SD 548	SD 548 G	440	260	740	43	59	340	880	330	85	515	200
	SD 648	SD 648 G	500	300	830	50	67	390	990	380	100	590	230
240	SD 3052 S	SD 3052 SG	400	240	680	43	59	340	820	320	70	475	190
	SD 3152 S	SD 3152 SG	440	260	740	43	59	360	880	350	85	515	200
	SD 552	SD 552 G	480	280	790	43	59	370	940	360	85	560	210
	SD 652	SD 652 G	540	325	890	50	67	410	1 060	400	100	640	250
260	SD 3056 S	SD 3056 SG	420	250	710	43	59	350	860	340	85	500	200
	SD 3156 S	SD 3156 SG	460	280	770	43	59	360	920	350	85	550	210
	SD 556	SD 556 G	500	300	830	50	67	390	990	380	100	590	230
	SD 656	SD 656 G	580	355	930	57	77	440	1 110	430	110	690	270

$g_{H13}$	$g_1_{H13}$	$t_{nominal}$	$s_{nominal}$	Mass (kg) approx	Applicable Parts			Oil Seals <sup>(2)</sup>
					Spherical Roller Bearing Numbers	Basic Dynamic Load Ratings $C_r$ (N)	Adapter Numbers	
77	67	M 24	M 30	70	23034 CDKE4	640 000	H 3034	GS 34
98	88	M 24	M 30	75	23134 CKE4	940 000	H 3134	GS 34
96	86	M 24	M 30	100	22234 CDKE4	990 000	H 3134	GS 34
130	120	M 30	M 30	160	22334 CAKE4	1 580 000	H 2334	GS 34
84	74	M 24	M 30	79	23036 CDKE4	750 000	H 3036	GS 36
106	96	M 24	M 30	94	23136 CKE4	1 050 000	H 3136	GS 36
96	86	M 24	M 30	110	22236 CDKE4	1 020 000	H 3136	GS 36
136	126	M 30	M 36	195	22336 CAKE4	1 740 000	H 2336	GS 36
85	75	M 24	M 30	87	23038 CAKE4	775 000	H 3038	GS 38
114	104	M 24	M 30	110	23138 CKE4	1 190 000	H 3138	GS 38
102	92	M 30	M 30	130	22238 CAKE4	1 140 000	H 3138	GS 38
142	132	M 30	M 36	210	22338 CAKE4	1 890 000	H 2338	GS 38
92	82	M 24	M 30	100	23040 CAKE4	940 000	H 3040	GS 40
122	112	M 30	M 30	130	23140 CKE4	1 360 000	H 3140	GS 40
108	98	M 30	M 30	155	22240 CAKE4	1 300 000	H 3140	GS 40
148	138	M 36	M 36	240	22340 CAKE4	2 000 000	H 2340	GS 40
100	90	M 30	M 30	130	23044 CAKE4	1 090 000	H 3044	GS 44
130	120	M 30	M 36	180	23144 CKE4	1 570 000	H 3144	GS 44
118	108	M 30	M 36	205	22244 CAKE4	1 570 000	H 3144	GS 44
155	145	M 36	M 36	315	22344 CAKE4	2 350 000	H 2344	GS 44
102	92	M 30	M 30	160	23048 CAKE4	1 160 000	H 3048	GS 48
138	128	M 30	M 36	210	23148 CKE4	1 790 000	H 3148	GS 48
130	120	M 36	M 36	240	22248 CAKE4	1 870 000	H 3148	GS 48
165	155	M 36	M 42	405	22348 CAKE4	2 600 000	H 2348	GS 48
114	104	M 30	M 36	210	23052 CAKE4	1 430 000	H 3052	GS 52
154	144	M 36	M 36	240	23152 CAKE4	2 160 000	H 3152	GS 52
140	130	M 36	M 36	315	22252 CAKE4	2 180 000	H 3152	GS 52
175	165	M 36	M 42	480	22352 CAKE4	3 100 000	H 2352	GS 52
116	106	M 36	M 36	240	23056 CAKE4	1 540 000	H 3056	GS 56
156	146	M 36	M 36	315	23156 CAKE4	2 230 000	H 3156	GS 56
140	130	M 36	M 42	390	22256 CAKE4	2 280 000	H 3156	GS 56
185	175	M 42	M 48	610	22356 CAKE4	3 500 000	H 2356	GS 56

Note <sup>(1)</sup> Including oil seal.

To place an order for a complete unit, please specify, "Plummer block bearing box+bearing+adapter".

- Remarks
- The threads for oil replenishing hole plugs are R 1/4 and those for drain plugs are R 3/8.
  - The plummer block bearing boxes listed above are provided with eye bolts.

Note <sup>(2)</sup> Applicable to the ZF Type with the same number.



# LARGE-SIZE PLUMMER BLOCKS

SD 30 S, SD 31 S, SD 5 Types  
Shaft Diameter 280~450 mm

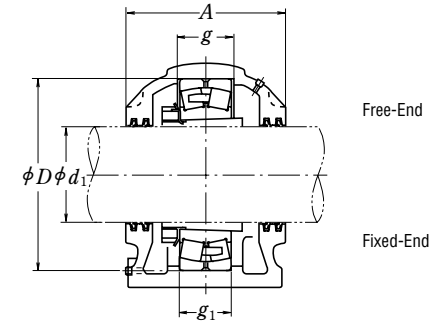
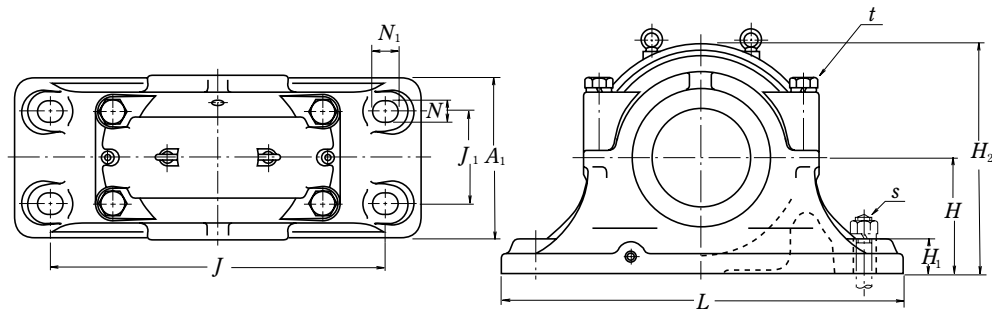

Shaft Diameter (mm) $d_1$	Plummer Block Bearing Box Numbers <sup>(1)</sup>		Dimensions (mm)										
	Free-End	Fixed-End	$D$	$H$	$J$	$N$	$N_1$	$A$	$L$	$A_1$	$H_1$	$H_2$	$J_1$
			H8	h13									
280	SD 3060 S	SD 3060 SG	460	280	770	43	59	360	920	350	85	550	210
	SD 3160 S	SD 3160 SG	500	300	830	50	67	390	990	380	100	590	230
	SD 560	SD 560 G	540	325	890	50	67	410	1 060	400	100	640	250
300	SD 3064 S	SD 3064 SG	480	280	790	43	59	380	940	360	85	560	210
	SD 3164 S	SD 3164 SG	540	325	890	50	67	430	1 060	400	100	640	250
	SD 564	SD 564 G	580	355	930	57	77	440	1 110	430	110	690	270
320	SD 3068 S	SD 3068 SG	520	310	860	50	67	400	1 020	370	100	615	230
	SD 3168 S	SD 3168 SG	580	355	930	57	77	470	1 110	450	110	690	270
340	SD 3072 S	SD 3072 SG	540	325	890	50	67	410	1 060	390	100	640	250
	SD 3172 S	SD 3172 SG	600	365	960	57	77	470	1 140	460	120	710	310
360	SD 3076 S	SD 3076 SG	560	340	900	50	67	410	1 080	390	100	665	260
	SD 3176 S	SD 3176 SG	620	375	980	57	77	500	1 160	490	120	735	320
380	SD 3080 S	SD 3080 SG	600	365	960	57	77	430	1 140	420	120	710	270
	SD 3180 S	SD 3180 SG	650	390	1 040	57	77	520	1 220	510	125	765	340
400	SD 3084 S	SD 3084 SG	620	375	980	57	77	430	1 160	420	120	735	270
	SD 3184 S	SD 3184 SG	700	420	1 070	57	77	560	1 250	550	135	830	380
410	SD 3088 S	SD 3088 SG	650	390	1 040	57	77	460	1 220	450	125	765	280
430	SD 3092 S	SD 3092 SG	680	405	1 040	57	77	470	1 220	460	130	790	310
450	SD 3096 S	SD 3096 SG	700	415	1 100	57	77	485	1 280	470	130	820	320

$g$ H13	$g_1$ H13	$t$ nominal	$s$ nominal	Mass (kg) approx	Applicable Parts			Oil Seals <sup>(2)</sup>
					Spherical Roller Bearing Numbers	Basic Dynamic Load Ratings $C_r$ (N)	Adapter Numbers	
128	118	M 36	M 36	300	23060 CAKE4	1 920 000	H 3060	GS 60
170	160	M 36	M 42	405	23160 CAKE4	2 670 000	H 3160	GS 60
150	140	M 36	M 42	465	22260 CAKE4	2 610 000	H 3160	GS 60
131	121	M 36	M 36	320	23064 CAKE4	1 960 000	H 3064	GS 64
186	176	M 36	M 42	480	23164 CAKE4	3 050 000	H 3164	GS 64
160	150	M 42	M 48	595	22264 CAKE4	2 990 000	H 3164	GS 64
143	133	M 36	M 42	410	23068 CAKE4	2 280 000	H 3068	GS 68
200	190	M 42	M 48	650	23168 CAKE4	3 600 000	H 3168	GS 68
144	134	M 36	M 42	465	23072 CAKE4	2 390 000	H 3072	GS 72
202	192	M 42	M 48	700	23172 CAKE4	3 800 000	H 3172	GS 72
145	135	M 36	M 42	480	23076 CAKE4	2 500 000	H 3076	GS 76
204	194	M 42	M 48	940	23176 CAKE4	4 000 000	H 3176	GS 76
158	148	M 42	M 48	690	23080 CAKE4	2 970 000	H 3080	GS 80
210	200	M 42	M 48	1 040	23180 CAKE4	4 150 000	H 3180	GS 80
160	150	M 42	M 48	770	23084 CAKE4	2 910 000	H 3084	GS 84
234	224	M 48	M 48	1 150	23184 CAKE4	5 000 000	H 3184	GS 84
167	157	M 42	M 48	870	23088 CAKE4	3 150 000	H 3088	GS 88
173	163	M 48	M 48	940	23092 CAKE4	3 450 000	H 3092	GS 92
175	165	M 48	M 48	1 040	23096 CAKE4	3 800 000	H 3096	GS 96

Note <sup>(1)</sup> Including oil seal.

To place an order for a complete unit, please specify, "Plummer block bearing box+bearing+adapter".

Remarks 1. The threads for oil replenishing hole plugs are R 1/4 and those for drain plugs are R 3/8.

2. The plummer block bearing boxes listed above are provided with eye bolts.

Note <sup>(2)</sup> Applicable to the ZF Type with the same number.

SG 5, SG 5-0 Types  
Shaft Diameter 50~180 mm

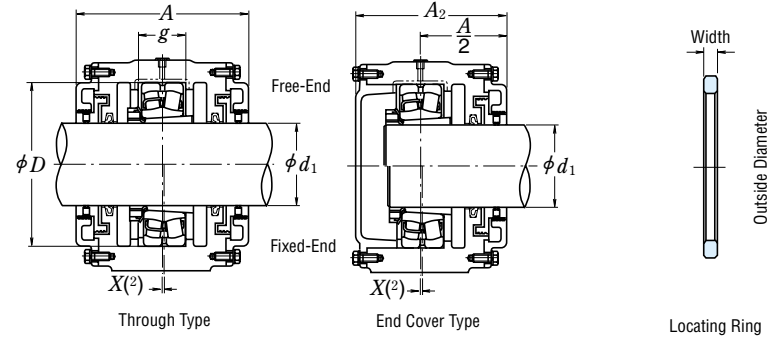
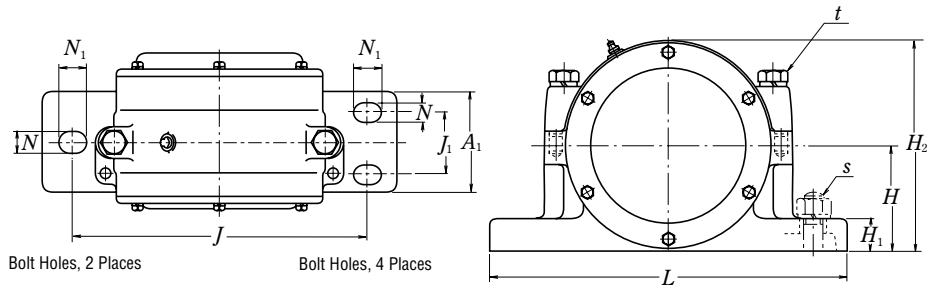

Shaft Diameter (mm) $d_1$	Plummer Block Bearing Box Numbers <sup>(1)</sup>		Dimensions (mm)												
	Through Type	End Cover Type	$D$	$H$	$J$	$N$	$N_1$	$A$	$L$	$A_1$	$H_1$	$H_2$	$J_1$	$A_2$	$g$
			H8	h13											
50	SG 511	SG 511-0	100	70	210	18	23	125	255	70	23	137	—	112.5	29
55	SG 512	SG 512-0	110	80	230	18	23	145	290	80	25	160	—	135	32
60	SG 513	SG 513-0	120	83	230	18	23	130	290	70	25	155	—	115	36
65	SG 515	SG 515-0	130	90	230	18	23	135	290	80	25	168	—	120	36
70	SG 516	SG 516-0	140	95	270	22	27	165	340	120	30	180	70	155	38
75	SG 517	SG 517-0	150	100	280	22	27	170	350	120	30	190	70	160	41
80	SG 518	SG 518-0	160	100	290	22	27	180	360	120	35	200	70	170	45
90	SG 520	SG 520-0	180	125	340	22	27	200	410	130	35	240	70	185	51
100	SG 522	SG 522-0	200	140	380	22	27	210	460	130	40	265	70	190	58
110	SG 524	SG 524-0	215	140	380	22	27	230	460	130	45	275	80	200	63
115	SG 526	SG 526-0	230	150	410	26	32	240	490	160	45	295	80	220	69
125	SG 528	SG 528-0	250	160	435	26	32	245	520	160	50	310	80	220	73
135	SG 530	SG 530-0	270	160	465	26	32	265	550	170	50	330	100	240	78
140	SG 532	SG 532-0	290	170	490	26	32	285	580	170	50	350	100	250	85
150	SG 534	SG 534-0	310	180	550	33	42	300	640	180	55	380	100	265	91
160	SG 536	SG 536-0	320	190	600	33	42	325	690	190	55	400	110	285	91
170	SG 538	SG 538-0	340	200	620	42	52	340	730	200	60	420	120	295	97
180	SG 540	SG 540-0	360	210	635	42	52	350	750	210	60	445	130	310	103

$t$ nominal	$s$ nominal	Mass (kg) approx		Applicable Parts				Oil Seals <sup>(3)</sup>
		Through Type	End Cover Type	Spherical Roller Bearing Numbers	Basic Dynamic Load Ratings $C_r$ (N)	Adapter Numbers	Locating Ring Nominal (Outside Dia.xWidth) Q'ty	
M 12	M 16	8.5	7.5	22211 EAKE4	119 000	H 311 X	SR 100x4 1	GS 11
M 16	M 16	15	14	22212 EAKE4	142 000	H 312 X	SR 110x4 1	GS 12
M 16	M 16	9.5	8.5	22213 EAKE4	177 000	H 313 X	SR 120x5 1	GS 13
M 16	M 16	12.5	11	22215 EAKE4	190 000	H 315 X	SR 130x5 1	GS 15
M 20	M 20	18.5	17	22216 EAKE4	212 000	H 316 X	SR 140x5 1	GS 16
M 20	M 20	21	20	22217 EAKE4	250 000	H 317 X	SR 150x5 1	GS 17
M 20	M 20	25	23	22218 EAKE4	289 000	H 318 X	SR 160x5 1	GS 18
M 20	M 20	37	34	22220 EAKE4	365 000	H 320 X	SR 180x5 1	GS 20
M 20	M 20	50	45	22222 EAKE4	485 000	H 322 X	SR 200x5 1	GS 22
M 20	M 20	59	53	22224 EAKE4	550 000	H 3124	SR 215x5 1	GS 24
M 24	M 24	67	62	22226 EAKE4	655 000	H 3126	SR 230x5 1	GS 26
M 24	M 24	73	68	22228 CDKE4	645 000	H 3128	SR 250x5 1	GS 28
M 24	M 24	90	80	22230 CDKE4	765 000	H 3130	SR 270x5 1	GS 30
M 24	M 24	105	92	22232 CDKE4	910 000	H 3132	SR 290x5 1	GS 32
M 30	M 30	130	115	22234 CDKE4	990 000	H 3134	SR 310x5 1	GS 34
M 30	M 30	155	135	22236 CDKE4	1 020 000	H 3136	SR 320x5 1	GS 36
M 36	M 36	175	155	22238 CAKE4	1 140 000	H 3138	SR 340x5 1	GS 38
M 36	M 36	210	180	22240 CAKE4	1 300 000	H 3140	SR 360x5 1	GS 40

**Note** <sup>(1)</sup> Including oil seal.  
To place an order for a complete unit, please specify, "Plummer block bearing box+bearing+adapter+locating ring".  
**Remarks** 1. The threads for grease nipples are R 1/8 for SG518 and under, and R 1/4 for SG520 and over.  
2. Bearing boxes larger than SG520 are provided with eye bolts.

**Notes** <sup>(2)</sup> The X dimension indicates the offset of the bearing center from the center of plummer block bearing box, and it is 1/2 of the locating ring width.  
<sup>(3)</sup> Applicable to the ZF Type with the same number.

# STEPPED-SHAFT TYPE PLUMMER BLOCKS

SN 2 C, SN 3 C Types  
Shaft Diameter 25~55 mm

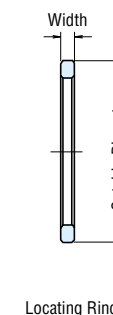
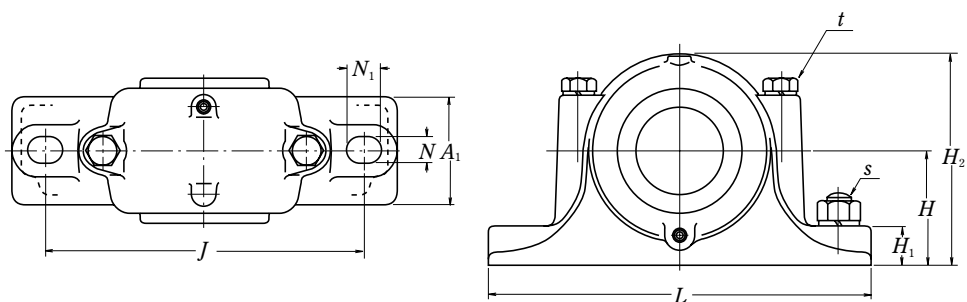

Shaft Diameter (mm) <i>d</i>	Plummer Block Bearing Box Numbers <sup>(1)</sup>	Dimensions (mm)														
		<i>d</i> <sub>1</sub>	<i>d</i> <sub>2</sub>	<i>D</i> <sub>H8</sub>	<i>H</i> <sub>h13</sub>	<i>J</i>	<i>N</i>	<i>N</i> <sub>1</sub>	<i>A</i>	<i>L</i>	<i>A</i> <sub>1</sub>	<i>H</i> <sub>1</sub>	<i>H</i> <sub>2</sub>	<i>g</i> <sub>H13</sub>	<i>t</i> <sub>nominal</sub>	<i>s</i> <sub>nominal</sub>
25	SN 205 C	30	20	52	40	130	15	20	67	165	46	22	75	25	M 8	M 12
	SN 305 C	30	20	62	50	150	15	20	80	185	52	22	90	34	M 8	M 12
30	SN 206 C	35	25	62	50	150	15	20	77	185	52	22	90	30	M 8	M 12
	SN 306 C	35	25	72	50	150	15	20	82	185	52	22	95	37	M 10	M 12
35	SN 207 C	45	30	72	50	150	15	20	82	185	52	22	95	33	M 10	M 12
	SN 307 C	45	30	80	60	170	15	20	90	205	60	25	110	41	M 10	M 12
40	SN 208 C	50	35	80	60	170	15	20	85	205	60	25	110	33	M 10	M 12
	SN 308 C	50	35	90	60	170	15	20	95	205	60	25	115	43	M 10	M 12
45	SN 209 C	55	40	85	60	170	15	20	85	205	60	25	112	31	M 10	M 12
	SN 309 C	55	40	100	70	210	18	23	105	255	70	28	130	46	M 12	M 16
50	SN 210 C	60	45	90	60	170	15	20	90	205	60	25	115	33	M 10	M 12
	SN 310 C	60	45	110	70	210	18	23	115	255	70	30	135	50	M 12	M 16
55	SN 211 C	65	50	100	70	210	18	23	95	255	70	28	130	33	M 12	M 16
	SN 311 C	65	50	120	80	230	18	23	120	275	80	30	150	53	M 12	M 16

Note <sup>(1)</sup> Including oil seal.

To place an order for a complete unit, please specify, "Plummer block bearing box+bearing+nut+washer+locating ring".

Remarks The threads for plugs are R 1/8.

Mass (kg) approx	Applicable Parts								Oil Seals <sup>(3)</sup>	
	Self-Aligning Ball Bearing Numbers	B. D. L. R. <sup>(4)</sup> C <sub>r</sub> (N)	Spherical Roller Bearing Numbers	B. D. L. R. <sup>(4)</sup> C <sub>r</sub> (N)	Nut Numbers	Washer Numbers	Locating Ring Nominal (Outside Dia.×Width)	Qty	Side <i>d</i> <sub>1</sub>	Side <i>d</i> <sub>2</sub>
1.1	1205	12 200	—	—	AN 05	AW 05X	SR 52 × 5	2	GS 7	GS 5
	2205	12 400	22205 CE4	37 500	AN 05	AW 05X	SR 52 × 7	1		
1.6	1305	18 200	21305 CDE4	43 000	AN 05	AW 05X	SR 62 × 8.5	2	GS 7	GS 5
	2305	24 900	—	—	AN 05	AW 05X	SR 62 × 10	1		
1.7	1206	15 800	—	—	AN 06	AW 06X	SR 62 × 7	2	GS 8	GS 6
	2206	15 300	22206 CE4	50 000	AN 06	AW 06X	SR 62 × 10	1		
1.8	1306	21 400	21306 CDE4	55 000	AN 06	AW 06X	SR 72 × 9	2	GS 8	GS 6
	2306	32 000	—	—	AN 06	AW 06X	SR 72 × 10	1		
1.9	1207	15 900	—	—	AN 07	AW 07X	SR 72 × 8	2	GS 10	GS 7
	2207	21 700	22207 CE4	69 000	AN 07	AW 07X	SR 72 × 10	1		
2.6	1307	25 300	21307 CDE4	71 500	AN 07	AW 07X	SR 80 × 10	2	GS 10	GS 7
	2307	40 000	—	—	AN 07	AW 07X	SR 80 × 10	1		
2.6	1208	19 300	—	—	AN 08	AW 08X	SR 80 × 7.5	2	GS 11	GS 8
	2208	22 400	22208 EAE4	90 500	AN 08	AW 08X	SR 80 × 10	1		
2.9	1308	29 800	21308 EAE4	94 500	AN 08	AW 08X	SR 90 × 10	2	GS 11	GS 8
	2308	45 500	22308 EAE4	136 000	AN 08	AW 08X	SR 90 × 10	1		
2.8	1209	22 000	—	—	AN 09	AW 09X	SR 85 × 6	2	GS 12	GS 9
	2209	23 300	22209 EAE4	94 500	AN 09	AW 09X	SR 85 × 8	1		
4.1	1309	38 500	21309 EAE4	119 000	AN 09	AW 09X	SR 100 × 10.5	2	GS 12	GS 9
	2309	55 000	22309 EAE4	166 000	AN 09	AW 09X	SR 100 × 10	1		
3.0	1210	22 800	—	—	AN 10	AW 10X	SR 90 × 6.5	2	GS 13	GS 10
	2210	23 400	22210 EAE4	99 000	AN 10	AW 10X	SR 90 × 10	1		
4.7	1310	43 500	21310 EAE4	142 000	AN 10	AW 10X	SR 110 × 11.5	2	GS 13	GS 10
	2310	65 000	22310 EAE4	197 000	AN 10	AW 10X	SR 110 × 10	1		
4.5	1211	26 900	—	—	AN 11	AW 11X	SR 100 × 6	2	GS 15	GS 11
	2211	26 700	22211 EAE4	119 000	AN 11	AW 11X	SR 100 × 8	1		
5.8	1311	51 500	21311 EAE4	142 000	AN 11	AW 11X	SR 120 × 12	2	GS 15	GS 11
	2311	76 500	22311 EAE4	234 000	AN 11	AW 11X	SR 120 × 10	1		

Notes <sup>(2)</sup> The *X* dimension indicates the offset of the bearing center from the center of the plummer block bearing box. When one locating ring is used, it is 1/2 of the locating ring width, and when two rings are used, it becomes 0.

<sup>(3)</sup> Applicable to the ZF Type with the same number. <sup>(4)</sup> B. D. L. R. : Basic Dynamic Load Ratings

# STEPPED-SHAFT TYPE PLUMMER BLOCKS

SN 2 C, SN 3 C Types  
Shaft Diameter 60~90 mm

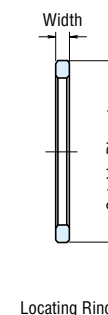
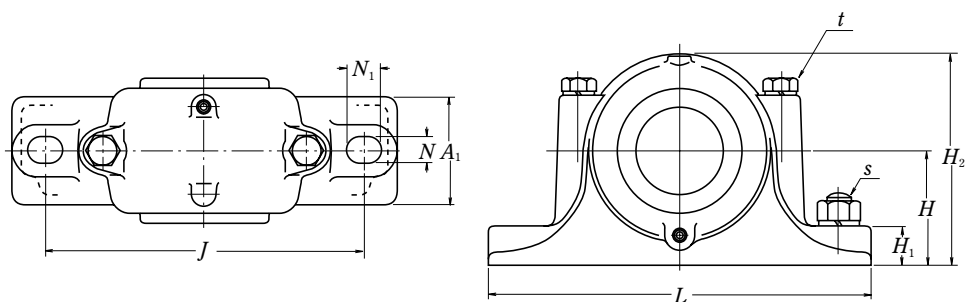

Shaft Diameter (mm) <i>d</i>	Plummer Block Bearing Box Numbers <sup>(1)</sup>	Dimensions (mm)														
		<i>d</i> <sub>1</sub>	<i>d</i> <sub>2</sub>	<i>D</i> <sub>H8</sub>	<i>H</i> <sub>h13</sub>	<i>J</i>	<i>N</i>	<i>N</i> <sub>1</sub>	<i>A</i>	<i>L</i>	<i>A</i> <sub>1</sub>	<i>H</i> <sub>1</sub>	<i>H</i> <sub>2</sub>	<i>g</i> <sub>H13</sub>	<i>t</i> <sub>nominal</sub>	<i>s</i> <sub>nominal</sub>
60	SN 212 C	70	55	110	70	210	18	23	105	255	70	30	135	38	M12	M16
	SN 312 C	70	55	130	80	230	18	23	125	280	80	30	155	56	M12	M16
65	SN 213 C	75	60	120	80	230	18	23	110	275	80	30	150	43	M12	M16
	SN 313 C	75	60	140	95	260	22	27	130	315	90	32	175	58	M16	M20
70	SN 214 C	80	65	125	80	230	18	23	115	275	80	30	155	44	M12	M16
	SN 314 C	80	65	150	95	260	22	27	130	320	90	32	185	61	M16	M20
75	SN 215 C	85	70	130	80	230	18	23	115	280	80	30	155	41	M12	M16
	SN 315 C	85	70	160	100	290	22	27	140	345	100	35	195	65	M16	M20
80	SN 216 C	90	75	140	95	260	22	27	120	315	90	32	175	43	M16	M20
	SN 316 C	90	75	170	112	290	22	27	145	345	100	35	212	68	M16	M20
85	SN 217 C	95	80	150	95	260	22	27	125	320	90	32	185	46	M16	M20
	SN 317 C	95	80	180	112	320	26	32	155	380	110	40	218	70	M20	M24
90	SN 218 C	100	85	160	100	290	22	27	145	345	100	35	195	62.4	M16	M20
	SN 318 C	105	85	190	112	320	26	32	160	380	110	40	225	74	M20	M24

Note <sup>(1)</sup> Including oil seal.

To place an order for a complete unit, please specify, "Plummer block bearing box+bearing+nut+washer+locating ring".

Remarks The threads for plugs are R 1/8 for SN316C, SN218C, and under and R 1/4 for SN317C and over.

Mass (kg) approx	Applicable Parts						Oil Seals <sup>(3)</sup>			
	Self-Aligning Ball Bearing Numbers	B. D. L. R. <sup>(4)</sup> C <sub>r</sub> (N)	Spherical Roller Bearing Numbers	B. D. L. R. <sup>(4)</sup> C <sub>r</sub> (N)	Nut Numbers	Washer Numbers	Locating Ring Nominal (Outside Dia.×Width)	Qty	Side <i>d</i> <sub>1</sub>	Side <i>d</i> <sub>2</sub>
5.0	1212	30 500	—	—	AN 12	AW 12X	SR 110 × 8	2	GS 16	GS 12
	2212	34 000	22212 EAE4	142 000	AN 12	AW 12X	SR 110 × 10	1		
6.5	1312	57 500	21312 EAE4	190 000	AN 12	AW 12X	SR 130 × 12.5	2	GS 16	GS 12
	2312	88 500	22312 EAE4	271 000	AN 12	AW 12X	SR 130 × 10	1		
5.6	1213	31 000	—	—	AN 13	AW 13X	SR 120 × 10	2	GS 17	GS 13
	2213	43 500	22213 EAE4	177 000	AN 13	AW 13X	SR 120 × 12	1		
8.7	1313	62 500	21313 EAE4	212 000	AN 13	AW 13X	SR 140 × 12.5	2	GS 17	GS 13
	2313	97 000	22313 EAE4	300 000	AN 13	AW 13X	SR 140 × 10	1		
6.2	1214	35 000	—	—	AN 14	AW 14X	SR 125 × 10	2	GS 18	GS 15
	2214	44 000	22214 EAE4	180 000	AN 14	AW 14X	SR 125 × 13	1		
10	1314	65 000	21314 EAE4	250 000	AN 14	AW 14X	SR 150 × 13	2	GS 18	GS 15
	2314	111 000	22314 EAE4	340 000	AN 14	AW 14X	SR 150 × 10	1		
7.0	1215	39 000	—	—	AN 15	AW 15X	SR 130 × 8	2	GS 19	GS 16
	2215	44 500	22215 EAE4	190 000	AN 15	AW 15X	SR 130 × 10	1		
11.3	1315	80 000	21315 EAE4	250 000	AN 15	AW 15X	SR 160 × 14	2	GS 19	GS 16
	2315	125 000	22315 EAE4	390 000	AN 15	AW 15X	SR 160 × 10	1		
9.0	1216	40 000	—	—	AN 16	AW 16X	SR 140 × 8.5	2	GS 20	GS 17
	2216	49 000	22216 EAE4	212 000	AN 16	AW 16X	SR 140 × 10	1		
12.6	1316	89 000	21316 EAE4	284 000	AN 16	AW 16X	SR 170 × 14.5	2	GS 20	GS 17
	2316	130 000	22316 EAE4	435 000	AN 16	AW 16X	SR 170 × 10	1		
10	1217	49 500	—	—	AN 17	AW 17X	SR 150 × 9	2	GS 21	GS 18
	2217	58 500	22217 EAE4	250 000	AN 17	AW 17X	SR 150 × 10	1		
15	1317	98 500	21317 EAE4	289 000	AN 17	AW 17X	SR 180 × 14.5	2	GS 21	GS 18
	2317	142 000	22317 EAE4	480 000	AN 17	AW 17X	SR 180 × 10	1		
13	1218	57 500	—	—	AN 18	AW 18X	SR 160 × 16.2	2	GS 22	GS 19
	2218	70 500	22218 EAE4	289 000	AN 18	AW 18X	SR 160 × 11.2	2		
	—	—	23218 CE4	340 000	AN 18	AW 18X	SR 160 × 10	1		
19	1318	117 000	21318 EAE4	330 000	AN 18	AW 18X	SR 190 × 15.5	2	GS 23	GS 19
	2318	154 000	22318 EAE4	535 000	AN 18	AW 18X	SR 190 × 10	1		

Notes <sup>(2)</sup> The *X* dimension indicates the offset of the bearing center from the center of the plummer block bearing box. When one locating ring is used, it is 1/2 of the locating ring width, and when two rings are used, it becomes 0.

<sup>(3)</sup> Applicable to the ZF Type with the same number. <sup>(4)</sup> B. D. L. R. : Basic Dynamic Load Ratings

# STEPPED-SHAFT TYPE PLUMMER BLOCKS

SN 2 C, SN 3 C Types  
Shaft Diameter 95~160 mm

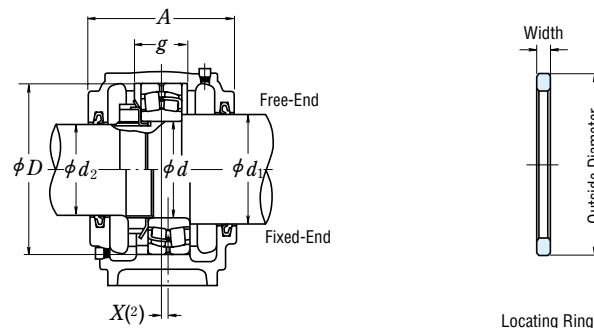
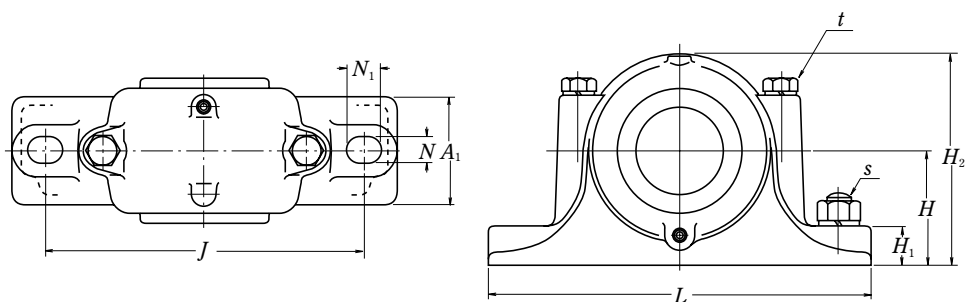

Shaft Diameter (mm) <i>d</i>	Plummer Block Bearing Box Numbers <sup>(1)</sup>	Dimensions (mm)														
		<i>d</i> <sub>1</sub>	<i>d</i> <sub>2</sub>	<i>D</i> <sub>H8</sub>	<i>H</i> <sub>h13</sub>	<i>J</i>	<i>N</i>	<i>N</i> <sub>1</sub>	<i>A</i>	<i>L</i>	<i>A</i> <sub>1</sub>	<i>H</i> <sub>1</sub>	<i>H</i> <sub>2</sub>	<i>g</i> <sub>H13</sub>	<i>t</i> <sub>nominal</sub>	<i>s</i> <sub>nominal</sub>
95	SN 219 C	110	90	170	112	290	22	27	140	345	100	35	210	53	M 16	M 20
	SN 319 C	110	90	200	125	350	26	32	170	410	120	45	245	77	M 20	M 24
100	SN 220 C	115	95	180	112	320	26	32	160	380	110	40	218	70.3	M 20	M 24
	SN 320 C	115	95	215	140	350	26	32	175	410	120	45	270	83	M 20	M 24
110	SN 222 C	125	105	200	125	350	26	32	175	410	120	45	240	80	M 20	M 24
	SN 322 C	125	105	240	150	390	28	36	190	450	130	50	300	90	M 24	M 24
120	SN 224 C	135	115	215	140	350	26	32	185	410	120	45	270	86	M 20	M 24
	SN 324 C	135	115	260	160	450	33	42	200	530	160	60	320	96	M 24	M 30
130	SN 226 C	145	125	230	150	380	28	36	190	445	130	50	290	90	M 24	M 24
	SN 326 C	150	125	280	170	470	33	42	210	550	160	60	340	103	M 24	M 30
140	SN 228 C	155	135	250	150	420	33	42	205	500	150	50	305	98	M 24	M 30
	SN 328 C	160	135	300	180	520	35	45	235	610	170	65	365	112	M 30	M 30
150	SN 230 C	165	145	270	160	450	33	42	220	530	160	60	325	106	M 24	M 30
	SN 330 C	170	145	320	190	560	35	45	245	650	180	65	385	118	M 30	M 30
160	SN 232 C	175	150	290	170	470	33	42	235	550	160	60	345	114	M 24	M 30
	SN 332 C	180	150	340	200	580	42	50	255	680	190	70	405	124	M 30	M 36

Note <sup>(1)</sup> Including oil seal.

To place an order for a complete unit, please specify, "Plummer block bearing+nut+washer+locating ring".

- Remarks
- The threads for plugs are R 1/8 for SN219C, and R 1/4 for SN319C and SN220C and over.
  - Bearing boxes larger than SN320C and SN224C are provided with eye bolts.

Mass (kg) approx	Applicable Parts								Oil Seals <sup>(3)</sup>	
	Self-Aligning Ball Bearing		Spherical Roller Bearing		Nut	Washer	Locating Ring		Side <i>d</i> <sub>1</sub>	Side <i>d</i> <sub>2</sub>
	Numbers	B. D. L. R. <sup>(4)</sup> <i>C</i> <sub>r</sub> (N)	Numbers	B. D. L. R. <sup>(4)</sup> <i>C</i> <sub>r</sub> (N)	Numbers	Numbers	Nominal (Outside Dia.×Width)	Qty		
15	1219	64 000	—	—	AN 19	AW 19X	SR 170 × 10.5	2	GS 24	GS 20
	2219	84 000	22219 EAE4	330 000	AN 19	AW 19X	SR 170 × 10	1		
	1319	129 000	21319 CE4	345 000	AN 19	AW 19X	SR 200 × 16	2	GS 24	GS 20
	2319	161 000	22319 EAE4	590 000	AN 19	AW 19X	SR 200 × 10	1		
18.5	1220	69 500	—	—	AN 20	AW 20X	SR 180 × 18.1	2	GS 26	GS 21
	2220	94 500	22220 EAE4	365 000	AN 20	AW 20X	SR 180 × 12.1	2		
	—	—	23220 CE4	420 000	AN 20	AW 20X	SR 180 × 10	1		
25	1320	140 000	21320 CE4	395 000	AN 20	AW 20X	SR 215 × 18	2	GS 26	GS 21
	2320	187 000	22320 EAE4	690 000	AN 20	AW 20X	SR 215 × 10	1		
20	1222	87 000	—	—	AN 22	AW 22X	SR 200 × 21	2	GS 28	GS 23
	2222	122 000	22222 EAE4	485 000	AN 22	AW 22X	SR 200 × 13.5	2		
	—	—	23222 CE4	515 000	AN 22	AW 22X	SR 200 × 10	1		
32	1322	161 000	21322 CAE4	395 000	AN 22	AW 22X	SR 240 × 20	2	GS 28	GS 23
	2322	211 000	22322 EAE4	825 000	AN 22	AW 22X	SR 240 × 10	1		
24.5	—	—	22224 EAE4	550 000	AN 24	AW 24	SR 215 × 14	2	GS 30	GS 26
	—	—	23224 CE4	630 000	AN 24	AW 24	SR 215 × 10	1		
48	—	—	22324 EAE4	955 000	AN 24	AW 24	SR 260 × 10	1	GS 30	GS 26
30	—	—	22226 EAE4	655 000	AN 26	AW 26	SR 230 × 13	2	GS 33	GS 28
	—	—	23226 CE4	700 000	AN 26	AW 26	SR 230 × 10	1		
56	—	—	22326 CE4	995 000	AN 26	AW 26	SR 280 × 10	1	GS 34	GS 28
38	—	—	22228 CDE4	645 000	AN 28	AW 28	SR 250 × 15	2	GS 35	GS 30
	—	—	23228 CE4	835 000	AN 28	AW 28	SR 250 × 10	1		
72	—	—	22328 CE4	1 160 000	AN 28	AW 28	SR 300 × 10	1	GS 36	GS 30
46	—	—	22230 CDE4	765 000	AN 30	AW 30	SR 270 × 16.5	2	GS 37	GS 33
	—	—	23230 CE4	975 000	AN 30	AW 30	SR 270 × 10	1		
98	—	—	22330 CAE4	1 220 000	AN 30	AW 30	SR 320 × 10	1	GS 38	GS 33
50	—	—	22232 CDE4	910 000	AN 32	AW 32	SR 290 × 17	2	GS 39	GS 34
	—	—	23232 CE4	1 100 000	AN 32	AW 32	SR 290 × 10	1		
115	—	—	22332 CAE4	1 360 000	AN 32	AW 32	SR 340 × 10	1	GS 40	GS 34

Note <sup>(2)</sup> The *X* dimension indicates the offset of the bearing center from the center of the plummer block bearing box. When one locating ring is used, it is 1/2 of the locating ring width, and when two rings are used, it becomes 0.

<sup>(3)</sup> Applicable to the ZF Type with the same number. <sup>(4)</sup> B. D. L. R. : Basic Dynamic Load Ratings

# STEPPED-SHAFT TYPE PLUMMER BLOCKS

SD 2 C, SD 3 C Types

Shaft Diameter 170~320 mm

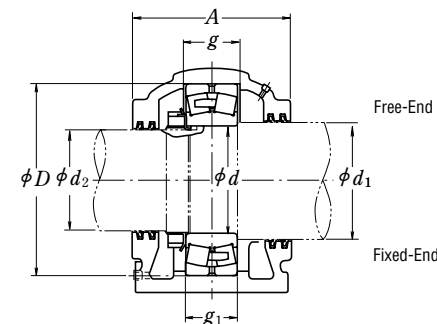
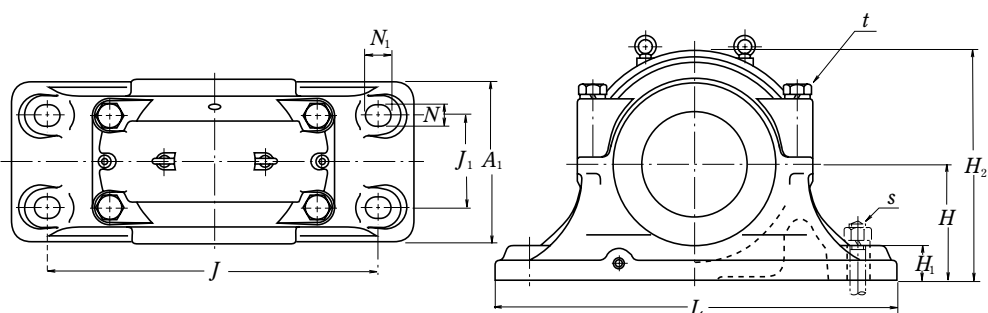

Shaft Diameter (mm) <i>d</i>	Plummer Block Bearing Box Numbers <sup>(1)</sup>		Dimensions (mm)												
	Free-End	Fixed-End	<i>d</i> <sub>1</sub>	<i>d</i> <sub>2</sub>	<i>D</i> <sub>H8</sub>	<i>H</i> <sub>h13</sub>	<i>J</i>	<i>N</i>	<i>N</i> <sub>1</sub>	<i>A</i>	<i>L</i>	<i>A</i> <sub>1</sub>	<i>H</i> <sub>1</sub>	<i>H</i> <sub>2</sub>	<i>J</i> <sub>1</sub>
170	SD 234 C	SD 234 CG	190	160	310	180	510	36	46	270	620	250	60	360	140
	SD 334 C	SD 334 CG	190	160	360	210	610	36	46	300	740	290	65	420	170
180	SD 236 C	SD 236 CG	200	170	320	190	540	36	46	280	650	260	60	380	150
	SD 336 C	SD 336 CG	200	170	380	225	640	43	59	320	780	310	70	450	180
190	SD 238 C	SD 238 CG	210	180	340	200	570	36	46	290	700	280	65	400	160
	SD 338 C	SD 338 CG	210	180	400	240	680	43	59	330	820	320	70	475	190
200	SD 240 C	SD 240 CG	220	190	360	210	610	36	46	300	740	290	65	420	170
	SD 340 C	SD 340 CG	220	190	420	250	710	43	59	350	860	340	85	500	200
220	SD 244 C	SD 244 CG	240	210	400	240	680	43	59	330	820	320	70	475	190
	SD 344 C	SD 344 CG	240	210	460	280	770	43	59	360	920	350	85	550	210
240	SD 248 C	SD 248 CG	260	230	440	260	740	43	59	340	880	330	85	515	200
	SD 348 C	SD 348 CG	260	230	500	300	830	50	67	390	990	380	100	590	230
260	SD 252 C	SD 252 CG	280	250	480	280	790	43	59	370	940	360	85	560	210
	SD 352 C	SD 352 CG	280	250	540	325	890	50	67	410	1 060	400	100	640	250
280	SD 256 C	SD 256 CG	300	260	500	300	830	50	67	390	990	380	100	590	230
	SD 356 C	SD 356 CG	300	260	580	355	930	57	77	440	1 110	430	110	690	270
300	SD 260 C	SD 260 CG	320	280	540	325	890	50	67	410	1 060	400	100	640	250
	SD 360 C	SD 360 CG	320	280	600	375	990	57	77	460	1 180	460	110	740	290
320	SD 264 C	SD 264 CG	340	300	580	355	930	57	77	440	1 110	430	110	690	270
	SD 364 C	SD 364 CG	340	300	640	405	1 030	64	84	490	1 230	490	120	790	310

Note <sup>(1)</sup> Including oil seal.

To place an order for a complete unit, please specify, "Plummer block bearing box+bearing+nut+washer or stopper".

Remarks 1. The threads for oil replenishing hole plugs are R 1/4 and those for drain plugs are R 3/8.

2. The plummer block bearing boxes listed above are provided with eye bolts.

<i>g</i> <sub>H13</sub>	<i>g</i> <sub>1</sub> <sub>H13</sub>	<i>t</i> <sub>nominal</sub>	<i>s</i> <sub>nominal</sub>	Mass (kg) approx	Applicable Parts			Oil Seals <sup>(2)</sup>		
					Spherical Roller Bearing Numbers	Nut Basic Dynamic Load Ratings <i>C</i> <sub>r</sub> (N)	Washer or Stopper Numbers	Side <i>d</i> <sub>1</sub>	Side <i>d</i> <sub>2</sub>	
96	86	M 24	M 30	100	22234 CDE4	990 000	AN 34	AW 34	GS 42	GS 36
130	120	M 30	M 30	160	22334 CAE4	1 580 000	AN 34	AW 34	GS 42	GS 36
96	86	M 24	M 30	110	22236 CDE4	1 020 000	AN 36	AW 36	GS 44	GS 38
136	126	M 30	M 36	195	22336 CAE4	1 740 000	AN 36	AW 36	GS 44	GS 38
102	92	M 30	M 30	130	22238 CAE4	1 140 000	AN 38	AW 38	GS 46	GS 40
142	132	M 30	M 36	210	22338 CAE4	1 890 000	AN 38	AW 38	GS 46	GS 40
108	98	M 30	M 30	155	22240 CAE4	1 300 000	AN 40	AW 40	GS 48	GS 42
148	138	M 36	M 36	240	22340 CAE4	2 000 000	AN 40	AW 40	GS 48	GS 42
118	108	M 30	M 36	205	22244 CAE4	1 570 000	AN 44	AL 44	GS 52	GS 46
155	145	M 36	M 36	315	22344 CAE4	2 350 000	AN 44	AL 44	GS 52	GS 46
130	120	M 36	M 36	240	22248 CAE4	1 870 000	AN 48	AL 44	GS 56	GS 50
165	155	M 36	M 42	405	22348 CAE4	2 600 000	AN 48	AL 44	GS 56	GS 50
140	130	M 36	M 36	315	22252 CAE4	2 180 000	AN 52	AL 52	GS 60	GS 54
175	165	M 36	M 42	480	22352 CAE4	3 100 000	AN 52	AL 52	GS 60	GS 54
140	130	M 36	M 42	390	22256 CAE4	2 280 000	AN 56	AL 52	GS 64	GS 56
185	175	M 42	M 48	610	22356 CAE4	3 500 000	AN 56	AL 52	GS 64	GS 56
150	140	M 36	M 42	465	22260 CAE4	2 610 000	AN 60	AL 60	GS 68	GS 60
160	150	M 42	M 48	595	22264 CAE4	2 990 000	AN 64	AL 64	GS 72	GS 64

Note <sup>(2)</sup> Applicable to the ZF Type with the same number.



## CYLINDRICAL ROLLER BEARINGS FOR SHEAVES

### CYLINDRICAL ROLLER BEARINGS FOR SHEAVES

Open Type Bore Diameter 50~560mm .....Pages B324~B327  
 Prelubricated Type Bore Diameter 40~400mm .....Pages B328~B329

### DESIGN, TYPES, AND FEATURES

Cylindrical Roller Bearings for sheaves are specially designed thin-walled, broad-width, full-complement type double-row cylindrical roller bearings, but they are widely used also for general industrial machines running at low speed and under heavy loads. There are several series as shown in Table 1.

**Table 1 Series of Cylindrical Roller Bearings for Sheaves**

Bearing Type		Fixed-End	Free-End
Open Type	Without Snap Ring	RS-48E4 RS-49E4	RSF-48E4 RSF-49E4
	Shielded Type	Without Snap Ring With Snap Ring	RS-50 RS-50NR



**Table 3**

Nominal Bore Dia. <i>d</i> (mm)	Clearances			
	CN		C3	
over incl	min	max	min	max
<b>30 40</b>	15	50	35	70
<b>40 50</b>	20	55	40	75
<b>50 65</b>	20	65	45	90
<b>65 80</b>	25	75	55	105
<b>80 100</b>	30	80	65	115
<b>100 120</b>	35	90	80	135
<b>120 140</b>	40	105	90	155
<b>140 160</b>	50	115	100	165
<b>160 180</b>	60	125	110	175
<b>180 200</b>	65	135	125	195
<b>200 225</b>	75	150	140	215
<b>225 250</b>	90	165	155	230
<b>250 280</b>	100	180	175	255
<b>280 315</b>	110	195	195	280
<b>315 355</b>	125	215	215	305
<b>355 400</b>	140	235	245	340
<b>400 450</b>	155	275	270	390
<b>450 500</b>	180	300	300	420

Since all are non-separable type bearings, the inner and outer rings cannot be separated, but the RSF type can be used as a free-end bearing. In this case, the permissible axial displacement is listed in the bearing tables.

Since cylindrical roller bearings for sheaves are a double-row, full-complement type, they can withstand heavy shock loads and moments and have sufficient axial load capacity for use in sheaves.

Since the shielded type is a kind of bearing unit, the number of parts surrounding the bearing can be reduced, so it allows for a simple compact design.

The surface of these bearings is treated for rust prevention.

### TOLERANCES AND

**RUNNING ACCURACY** .....Table 8.2 (Pages A60~A63)

### RECOMMENDED FITS AND INTERNAL CLEARANCES

When used with outer ring rotation for sheaves or wheels, the fit and radial internal clearance should conform to Table 2.

**Table 2 Fits and Internal Clearances for Cylindrical Roller Bearings for Sheaves**

Operating Conditions		Fitting between Inner Ring and Shaft	Fitting between Outer Ring and Housing Bore	Recommended Internal Clearance
Outer Ring Rotation	Thin walled housings and heavy loads	g6 or h6	P7	C3
	Normal to heavy loads	g6 or h6	N7	C3
	Light or fluctuating loads	g6 or h6	M7	CN

The fits listed in Tables 9.2 (Page A84) and 9.4 (Page A85) apply when they are used with inner ring rotation in general applications, and the internal clearance should conform to Table 3.

RS-48 · RS-49 Types  
RSF-48 · RSF-49 Types  
Bore Diameter 50~220 mm

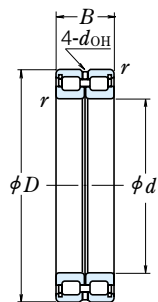

Fixed-End Bearing  
RS

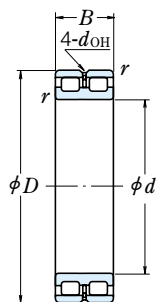

Free-End Bearing  
RSF

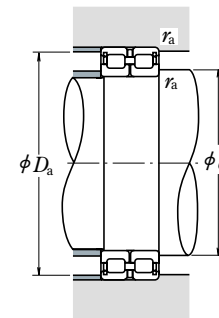

Boundary Dimensions (mm)				Basic Load Ratings (N)				Limiting Speeds (rpm)	
$d$	$D$	$B$	$r_{min}$	$C_r$	$C_{0r}$	{kgf}		Grease	Oil
						$C_r$	$C_{0r}$		
50	72	22	0.6	48 000	75 500	4 900	7 700	2 000	4 000
60	85	25	1	68 500	118 000	6 950	12 000	1 600	3 200
65	90	25	1	70 500	125 000	7 150	12 700	1 600	3 200
70	100	30	1	102 000	168 000	10 400	17 200	1 400	2 800
80	110	30	1	109 000	191 000	11 100	19 500	1 300	2 600
90	125	35	1.1	147 000	268 000	15 000	27 400	1 100	2 200
100	125	25	1	87 500	189 000	8 900	19 300	1 100	2 200
140	140	40	1.1	194 000	400 000	19 800	41 000	1 000	2 000
105	130	25	1	89 000	196 000	9 100	19 900	1 000	2 000
145	145	40	1.1	199 000	420 000	20 300	43 000	950	1 900
110	140	30	1	114 000	260 000	11 700	26 500	950	1 900
150	150	40	1.1	202 000	430 000	20 600	44 000	900	1 800
120	150	30	1	119 000	283 000	12 200	28 900	900	1 800
165	165	45	1.1	226 000	480 000	23 100	49 000	800	1 600
130	165	35	1.1	162 000	390 000	16 500	39 500	800	1 600
180	180	50	1.5	262 000	555 000	26 700	56 500	750	1 500
140	175	35	1.1	167 000	415 000	17 000	42 500	750	1 500
190	190	50	1.5	272 000	595 000	27 700	60 500	710	1 400
150	190	40	1.1	235 000	575 000	23 900	58 500	670	1 400
210	210	60	2	390 000	865 000	40 000	88 500	670	1 300
160	200	40	1.1	243 000	615 000	24 800	63 000	630	1 300
220	220	60	2	410 000	930 000	41 500	95 000	600	1 200
170	215	45	1.1	265 000	650 000	27 000	66 500	600	1 200
230	230	60	2	415 000	975 000	42 500	99 500	600	1 200
180	225	45	1.1	272 000	685 000	27 800	70 000	560	1 100
250	250	69	2	495 000	1 130 000	50 500	115 000	530	1 100
190	240	50	1.5	315 000	785 000	32 000	80 000	530	1 100
260	260	69	2	510 000	1 180 000	52 000	120 000	500	1 000
200	250	50	1.5	320 000	825 000	33 000	84 000	500	1 000
280	280	80	2.1	665 000	1 500 000	68 000	153 000	480	950
220	270	50	1.5	340 000	905 000	34 500	92 500	450	900
300	300	80	2.1	695 000	1 620 000	70 500	165 000	430	850

Remarks Cylindrical roller bearings for sheaves are designed for specific applications, when using them, please contact NSK.

Bearing Numbers <sup>(1)</sup>		Dimensions (mm)		Abutment and Fillet Dimensions (mm)			Mass (kg)
Fixed-End Bearing	Free-End Bearing	$d_{OH}^{(2)}$	Axial Disp. <sup>(3)</sup>	$d_a$ min	$D_a$ max	$r_a$ max	approx
RS-4910E4	RSF-4910E4	2.5	1.5	54	68	0.6	0.30
RS-4912E4	RSF-4912E4	2.5	1.5	65	80	1	0.46
RS-4913E4	RSF-4913E4	2.5	2	70	85	1	0.50
RS-4914E4	RSF-4914E4	3	2	75	95	1	0.79
RS-4916E4	RSF-4916E4	3	2	85	105	1	0.89
RS-4918E4	RSF-4918E4	3	2	96.5	118.5	1	1.35
RS-4820E4	RSF-4820E4	2.5	1.5	105	120	1	0.74
RS-4920E4	RSF-4920E4	3	2	106.5	133.5	1	1.97
RS-4821E4	RSF-4821E4	2.5	1.5	110	125	1	0.77
RS-4921E4	RSF-4921E4	3	2	111.5	138.5	1	2.05
RS-4822E4	RSF-4822E4	3	2	115	135	1	1.09
RS-4922E4	RSF-4922E4	3	2	116.5	143.5	1	2.15
RS-4824E4	RSF-4824E4	3	2	125	145	1	1.28
RS-4924E4	RSF-4924E4	4	3	126.5	158.5	1	2.95
RS-4826E4	RSF-4826E4	3	2	136.5	158.5	1	1.9
RS-4926E4	RSF-4926E4	5	3.5	138	172	1.5	3.95
RS-4828E4	RSF-4828E4	3	2	146.5	168.5	1	2.03
RS-4928E4	RSF-4928E4	5	3.5	148	182	1.5	4.25
RS-4830E4	RSF-4830E4	3	2	156.5	183.5	1	2.85
RS-4930E4	RSF-4930E4	5	3.5	159	201	2	6.65
RS-4832E4	RSF-4832E4	3	2	166.5	193.5	1	3.05
RS-4932E4	RSF-4932E4	5	3.5	169	211	2	7.0
RS-4834E4	RSF-4834E4	4	3	176.5	208.5	1	4.1
RS-4934E4	RSF-4934E4	4	3.5	179	221	2	7.35
RS-4836E4	RSF-4836E4	4	3	186.5	218.5	1	4.3
RS-4936E4	RSF-4936E4	6	4.5	189	241	2	10.7
RS-4838E4	RSF-4838E4	5	3.5	198	232	1.5	5.65
RS-4938E4	RSF-4938E4	6	4.5	199	251	2	11.1
RS-4840E4	RSF-4840E4	5	3.5	208	242	1.5	5.95
RS-4940E4	RSF-4940E4	7	5	211	269	2	15.7
RS-4844E4	RSF-4844E4	5	3.5	228	262	1.5	6.45
RS-4944E4	RSF-4944E4	7	5	231	289	2	17

Notes <sup>(1)</sup> The suffix E4 indicates that the outer ring is provided with oil holes and oil groove.

<sup>(2)</sup>  $d_{OH}$  represents the oil hole diameter in the outer ring.

<sup>(3)</sup> Permissible axial displacement for free-end bearings.

RS-48 · RS-49 Types  
RSF-48 · RSF-49 Types  
Bore Diameter 240~560 mm

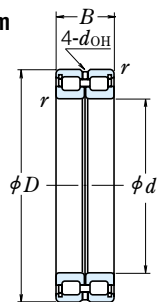

Fixed-End Bearing  
RS

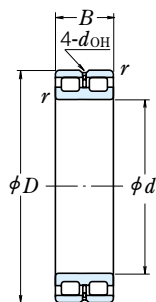

Free-End Bearing  
RSF

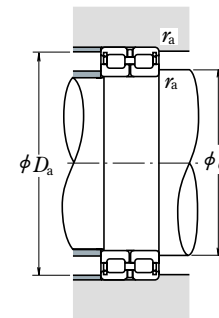

Boundary Dimensions (mm)				Basic Load Ratings				Limiting Speeds (rpm)	
d	D	B	r min	(N)		{kgf}		Grease	Oil
				C <sub>r</sub>	C <sub>0r</sub>	C <sub>r</sub>	C <sub>0r</sub>		
240	300	60	2	495 000	1 340 000	50 500	137 000	430	850
	320	80	2.1	725 000	1 770 000	74 000	181 000	400	800
260	320	60	2	515 000	1 450 000	52 500	148 000	380	750
	360	100	2.1	1 050 000	2 530 000	107 000	258 000	360	710
280	350	69	2	610 000	1 690 000	62 500	173 000	340	710
	380	100	2.1	1 090 000	2 720 000	111 000	277 000	340	670
300	380	80	2.1	805 000	2 160 000	82 000	220 000	320	630
	420	118	3	1 460 000	3 400 000	149 000	350 000	300	600
320	400	80	2.1	835 000	2 310 000	85 000	236 000	300	600
	440	118	3	1 500 000	3 600 000	153 000	365 000	280	560
340	420	80	2.1	855 000	2 430 000	87 500	248 000	280	560
	460	118	3	1 560 000	3 900 000	159 000	395 000	260	530
360	440	80	2.1	885 000	2 580 000	90 000	264 000	260	530
	480	118	3	1 600 000	4 050 000	163 000	415 000	260	500
380	480	100	2.1	1 260 000	3 600 000	128 000	365 000	240	500
	520	140	4	2 040 000	5 200 000	209 000	530 000	240	450
400	500	100	2.1	1 290 000	3 750 000	132 000	385 000	240	480
	540	140	4	2 100 000	5 450 000	214 000	555 000	220	450
420	520	100	2.1	1 320 000	3 950 000	135 000	405 000	220	450
	560	140	4	2 150 000	5 700 000	219 000	580 000	200	430
440	540	100	2.1	1 350 000	4 150 000	138 000	420 000	200	430
	600	160	4	2 840 000	7 350 000	289 000	750 000	190	380
460	580	118	3	1 730 000	5 150 000	177 000	525 000	190	380
	620	160	4	2 870 000	7 500 000	293 000	765 000	190	380
480	600	118	3	1 760 000	5 300 000	180 000	545 000	190	380
	650	170	5	3 200 000	8 500 000	325 000	865 000	180	360
500	620	118	3	1 810 000	5 600 000	184 000	570 000	180	360
	670	170	5	3 300 000	8 900 000	335 000	910 000	170	340
530	710	180	5	3 400 000	9 200 000	350 000	935 000	160	320
	750	190	5	3 800 000	10 100 000	385 000	1 030 000	150	300

**Remarks** Cylindrical roller bearings for sheaves are designed for specific applications, when using them, please contact NSK.

Bearing Numbers <sup>(1)</sup>		Dimensions (mm)		Abutment and Fillet Dimensions (mm)			Mass (kg)
Fixed-End Bearing	Free-End Bearing	d <sub>OH</sub> <sup>(2)</sup>	Axial Disp. <sup>(3)</sup>	d <sub>a</sub> min	D <sub>a</sub> max	r <sub>a</sub> max	approx
<b>RS-4948E4</b>	<b>RSF-4948E4</b>	7	5	251	309	2	18.4
<b>RS-4852E4</b>	<b>RSF-4852E4</b>	5	3.5	269	311	2	11
<b>RS-4952E4</b>	<b>RSF-4952E4</b>	8	6	271	349	2	32
<b>RS-4856E4</b>	<b>RSF-4856E4</b>	6	4.5	289	341	2	16
<b>RS-4956E4</b>	<b>RSF-4956E4</b>	8	6	291	369	2	34
<b>RS-4860E4</b>	<b>RSF-4860E4</b>	6	5	311	369	2	23
<b>RS-4960E4</b>	<b>RSF-4960E4</b>	9	7	313	407	2.5	52
<b>RS-4864E4</b>	<b>RSF-4864E4</b>	6	5	331	389	2	24.3
<b>RS-4964E4</b>	<b>RSF-4964E4</b>	9	7	333	427	2.5	55
<b>RS-4868E4</b>	<b>RSF-4868E4</b>	6	5	351	409	2	25.6
<b>RS-4968E4</b>	<b>RSF-4968E4</b>	9	7	353	447	2.5	58
<b>RS-4872E4</b>	<b>RSF-4872E4</b>	6	5	371	429	2	27
<b>RS-4972E4</b>	<b>RSF-4972E4</b>	9	7	373	467	2.5	61
<b>RS-4876E4</b>	<b>RSF-4876E4</b>	8	6	391	469	2	45.5
<b>RS-4976E4</b>	<b>RSF-4976E4</b>	11	8	396	504	3	90.5
<b>RS-4880E4</b>	<b>RSF-4880E4</b>	8	6	411	489	2	47.5
<b>RS-4980E4</b>	<b>RSF-4980E4</b>	11	8	416	524	3	94.5
<b>RS-4884E4</b>	<b>RSF-4884E4</b>	8	6	431	509	2	49.5
<b>RS-4984E4</b>	<b>RSF-4984E4</b>	11	8	436	544	3	98.5
<b>RS-4888E4</b>	<b>RSF-4888E4</b>	8	6	451	529	2	51.5
<b>RS-4988E4</b>	<b>RSF-4988E4</b>	11	8	456	584	3	136
<b>RS-4892E4</b>	<b>RSF-4892E4</b>	9	7	473	567	2.5	77.5
<b>RS-4992E4</b>	<b>RSF-4992E4</b>	11	8	476	604	3	142
<b>RS-4896E4</b>	<b>RSF-4896E4</b>	9	7	493	587	2.5	80.5
<b>RS-4996E4</b>	<b>RSF-4996E4</b>	12	9	500	630	4	167
<b>RS-48/500E4</b>	<b>RSF-48/500E4</b>	9	7	513	607	2.5	83.5
<b>RS-49/500E4</b>	<b>RSF-49/500E4</b>	12	9	520	650	4	173
<b>RS-49/530E4</b>	<b>RSF-49/530E4</b>	12	11	550	690	4	206
<b>RS-49/560E4</b>	<b>RSF-49/560E4</b>	12	11	580	730	4	231

**Notes** <sup>(1)</sup> The suffix E4 indicates that the outer ring is provided with oil holes and oil groove.

<sup>(2)</sup> d<sub>OH</sub> represents the oil hole diameter in the outer ring.

<sup>(3)</sup> Permissible axial displacement for free-end bearings.

RS-50 Type (Prelubricated)  
Bore Diameter 40~400 mm

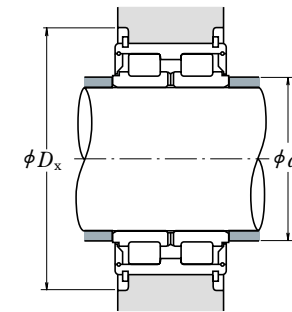
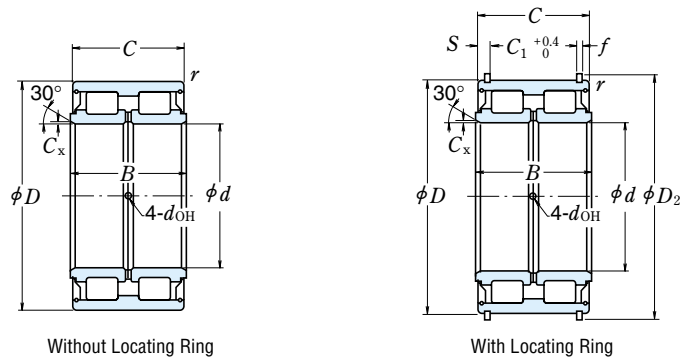

Boundary Dimensions (mm)						Basic Load Ratings				Limiting Speeds (rpm) Grease
d	D	B	C	C <sub>x</sub> <sup>(1)</sup> min	r min	C <sub>r</sub> (N)	C <sub>0r</sub> (kgf)	C <sub>r</sub>	C <sub>0r</sub>	
40	68	38	37	0.4	0.6	79 500	116 000	8 100	11 800	2 400
45	75	40	39	0.4	0.6	95 500	144 000	9 750	14 700	2 200
50	80	40	39	0.4	0.6	100 000	158 000	10 200	16 100	2 000
55	90	46	45	0.6	0.6	118 000	193 000	12 100	19 700	1 800
60	95	46	45	0.6	0.6	123 000	208 000	12 600	21 200	1 700
65	100	46	45	0.6	0.6	128 000	224 000	13 100	22 800	1 600
70	110	54	53	0.6	0.6	171 000	285 000	17 500	29 000	1 400
75	115	54	53	0.6	0.6	179 000	305 000	18 200	31 500	1 400
80	125	60	59	0.6	0.6	251 000	430 000	25 600	43 500	1 200
85	130	60	59	0.6	0.6	256 000	445 000	26 200	45 500	1 200
90	140	67	66	1	0.6	305 000	540 000	31 000	55 000	1 100
95	145	67	66	1	0.6	310 000	565 000	32 000	57 500	1 100
100	150	67	66	1	0.6	320 000	585 000	32 500	59 500	1 000
110	170	80	79	1.1	1	385 000	695 000	39 000	71 000	900
120	180	80	79	1.1	1	400 000	750 000	40 500	76 500	850
130	200	95	94	1.1	1	535 000	1 000 000	54 500	102 000	750
140	210	95	94	1.1	1	550 000	1 040 000	56 000	106 000	710
150	225	100	99	1.3	1	620 000	1 210 000	63 500	124 000	670
160	240	109	108	1.3	1.1	695 000	1 370 000	71 000	140 000	630
170	260	122	121	1.3	1.1	860 000	1 680 000	88 000	171 000	600
180	280	136	135	1.3	1.1	980 000	1 910 000	100 000	195 000	530
190	290	136	135	1.3	1.1	1 120 000	2 230 000	114 000	227 000	500
200	310	150	149	1.3	1.1	1 310 000	2 650 000	133 000	270 000	480
220	340	160	159	1.5	1.1	1 510 000	3 100 000	154 000	320 000	430
240	360	160	159	1.5	1.1	1 570 000	3 350 000	160 000	340 000	400
260	400	190	189	2	1.5	2 130 000	4 500 000	217 000	460 000	360
280	420	190	189	2	1.5	2 170 000	4 700 000	221 000	480 000	340
300	460	218	216	2	1.5	2 670 000	5 850 000	272 000	600 000	300
320	480	218	216	2	1.5	2 720 000	6 100 000	277 000	620 000	300
340	520	243	241	2.1	2	3 350 000	7 550 000	345 000	770 000	260
360	540	243	241	2.1	2	3 450 000	7 850 000	350 000	800 000	260
380	560	243	241	2.1	2	3 550 000	8 400 000	365 000	855 000	240
400	600	272	270	2.1	2	4 250 000	9 950 000	435 000	1 010 000	220

Note (1) Chamfer dimension of inner ring in radial direction.

- Remarks
1. Good quality grease is prepacked in bearings.
  2. Grease can be supplied through oil holes in the inner rings.

Bearing Numbers		Locating Ring Dimensions (mm)				Oil Holes (mm)	Abutment and Fillet Dimensions (mm)		Mass (kg)
Without Locating Ring	With Locating Ring	C <sub>1</sub>	S	D <sub>2</sub>	f	d <sub>OH</sub>	d <sub>a</sub> min	D <sub>x</sub> min	approx
RS-5008	RS-5008NR	28	4.5	71.8	2	2.5	43.5	77.5	0.56
RS-5009	RS-5009NR	30	4.5	78.8	2	2.5	48.5	84.5	0.70
RS-5010	RS-5010NR	30	4.5	83.8	2	2.5	53.5	89.5	0.76
RS-5011	RS-5011NR	34	5.5	94.8	2.5	3	60	101	1.17
RS-5012	RS-5012NR	34	5.5	99.8	2.5	3	65	106	1.25
RS-5013	RS-5013NR	34	5.5	104.8	2.5	3	70	111	1.32
RS-5014	RS-5014NR	42	5.5	114.5	2.5	3	75	121	1.87
RS-5015	RS-5015NR	42	5.5	119.5	2.5	3	80	126	2.0
RS-5016	RS-5016NR	48	5.5	129.5	2.5	3	85	136	2.65
RS-5017	RS-5017NR	48	5.5	134.5	2.5	3	90	141	2.75
RS-5018	RS-5018NR	54	6	145.4	2.5	4	96	153.5	3.75
RS-5019	RS-5019NR	54	6	150.4	2.5	4	101	158.5	3.95
RS-5020	RS-5020NR	54	6	155.4	2.5	4	106	163.5	4.05
RS-5022	RS-5022NR	65	7	175.4	2.5	5	116.5	183.5	6.1
RS-5024	RS-5024NR	65	7	188	3	5	126.5	197	7.0
RS-5026	RS-5026NR	77	8.5	207	3	5	136.5	217	10.6
RS-5028	RS-5028NR	77	8.5	217	3	5	146.5	227	11.3
RS-5030	RS-5030NR	81	9	232	3	6	157	242	13.7
RS-5032	RS-5032NR	89	9.5	247	3	6	167	257	16.8
RS-5034	RS-5034NR	99	11	270	4	6	177	285	22.2
RS-5036	RS-5036NR	110	12.5	294	5	6	187	318	30
RS-5038	RS-5038NR	110	12.5	304	5	6	197	328	32
RS-5040	RS-5040NR	120	14.5	324	5	6	207	352	41
RS-5044	RS-5044NR	130	14.5	356	6	7	228.5	382	53
RS-5048	RS-5048NR	130	14.5	376	6	7	248.5	402	57
RS-5052	RS-5052NR	154	17.5	416	7	8	270	444	86
RS-5056	RS-5056NR	154	17.5	436	7	8	290	472	92
RS-5060	RS-5060NR	178	19	476	7	8	310	512	130
RS-5064	—	—	—	—	—	8	330	—	135
RS-5068	—	—	—	—	—	10	352	—	185
RS-5072	—	—	—	—	—	10	372	—	192
RS-5076	—	—	—	—	—	10	392	—	196
RS-5080	—	—	—	—	—	10	412	—	280

- Remarks
3. Cylindrical roller bearings for sheaves are designed for specific applications, when using them, please contact NSK.
  4. For shield with outside diameter larger than 180mm, the above figure is different actual shape. For detail drawing, please contact NSK.

## ROLL-NECK BEARINGS

### FOUR-ROW TAPERED ROLLER BEARINGS

Bore Diameter 100~ 939.800mm.....Pages B298~B299

### FOUR-ROW CYLINDRICAL ROLLER BEARINGS

Bore Diameter 100~ 920mm.....Pages B300~B303

### DESIGN, TYPES, AND FEATURES

Four-row tapered roller bearings and four-row cylindrical roller bearings used for rolling-mill roll necks are easy to service and check, and are designed to have the highest load rating possible for the limited space around roll necks. Also, they are designed for high speed to satisfy the demand for fast rolling.

In addition to the open type (KV) four-row tapered roller bearings listed in this catalog, sealed-clean type four-row tapered roller bearings are also available. Please refer to “Large-Size Rolling Bearings” catalog (CAT. No. E125) or “Extra-Capacity Sealed-Clean™ Roll Neck Bearings” catalog (CAT. No. E1225) for more detailed information.

### TOLERANCES AND RUNNING ACCURACY

**METRIC DESIGN FOUR-ROW  
TAPERED ROLLER BEARINGS**.....Table 8.3 (Pages A64~A67)

**INCH DESIGN FOUR-ROW  
TAPERED ROLLER BEARINGS**.....Table 8.4 (Pages A68~A69)

**FOUR-ROW  
CYLINDRICAL ROLLER BEARINGS**.....Table 8.2 (Pages A60~A63)  
(Not applicable to combined width)

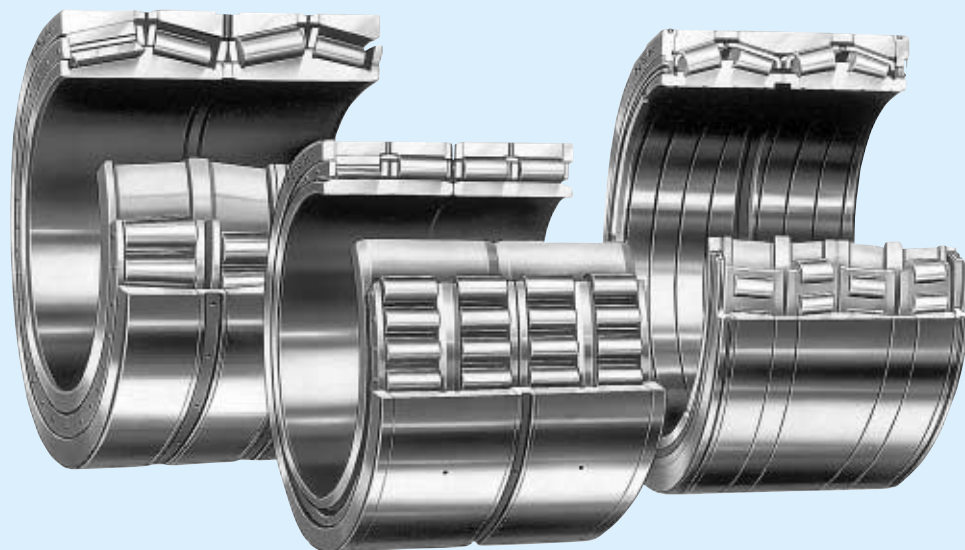

### RECOMMENDED FITS

#### FOUR-ROW TAPERED ROLLER BEARINGS (CYLINDRICAL BORES)

Tables 1 and 2 apply to metric series bearings and Tables 3 and 4 to inch design.

**Table 1 Fits of Metric Design Four-Row Tapered Roller Bearings with Roll Necks**

Units :  $\mu\text{m}$

Nominal Bore Diameter $d$ (mm)	Single Plane Mean Bore Dia. Deviation $\Delta d_{mp}$			Tolerance		Clearance		Wear Limits Ref.
		high	low	high	low	min	max	
80	120	0	-20	-120	-150	100	150	300
120	180	0	-25	-150	-175	125	175	350
180	250	0	-30	-175	-200	145	200	400
250	315	0	-35	-210	-250	175	250	500
315	400	0	-40	-240	-300	200	300	600
400	500	0	-45	-245	-300	200	300	600
500	630	0	-50	-250	-300	200	300	600
630	800	0	-75	-325	-400	250	400	800

Table 2 Fits of Metric Design Four-Row Tapered Roller Bearings with Chock

Units :  $\mu\text{m}$

Nominal Outside Diameter $D$ (mm)		Single Plane Mean Outside Dia. Deviation $\Delta D_{mp}$		Tolerance for Chock Bore Diameter		Clearance		Wear Limits of Chock
over	incl	high	low	high	low	min	max	Ref.
120	150	0	-18	+57	+25	25	75	150
150	180	0	-25	+100	+50	50	125	250
180	250	0	-30	+120	+50	50	150	300
250	315	0	-35	+115	+50	50	150	300
315	400	0	-40	+110	+50	50	150	300
400	500	0	-45	+105	+50	50	150	300
500	630	0	-50	+100	+50	50	150	300
630	800	0	-75	+150	+75	75	225	450
800	1 000	0	-100	+150	+75	75	250	500

Table 3 Fits of Inch Design Four-Row Tapered Roller Bearings with Roll Necks

Units :  $\mu\text{m}$

Nominal Bore Diameter $d$				Bore Diameter Deviation $\Delta d_s$		Tolerance for Roll Neck Diameter		Clearance		Wear Limits of Roll Neck
over (mm)		incl (mm)		high	low	high	low	min	max	Ref.
152.400	6.0000	203.200	8.0000	+25	0	-150	-175	150	200	400
203.200	8.0000	304.800	12.0000	+25	0	-175	-200	175	225	450
304.800	12.0000	609.600	24.0000	+51	0	-200	-250	200	301	600
609.600	24.0000	914.400	36.0000	+76	0	-250	-325	250	401	800
914.400	36.0000	—	—	+102	0	-300	-400	300	502	1 000

Table 4 Fits of Inch Design Four-Row Tapered Roller Bearings with Chocks

Units :  $\mu\text{m}$

Nominal Outside Diameter $D$				Outside Dia. Deviation $\Delta D_s$		Tolerance for Chock Bore Diameter		Clearance		Wear Limits of Chock
over (mm)		incl (mm)		high	low	high	low	min	max	Ref.
—	—	304.800	12.0000	+25	0	+75	+50	25	75	150
304.800	12.0000	609.600	24.0000	+51	0	+150	+100	49	150	300
609.600	24.0000	914.400	36.0000	+76	0	+225	+150	74	225	450
914.400	36.0000	1 219.200	48.0000	+102	0	+300	+200	98	300	600
1 219.200	48.0000	1 524.000	60.0000	+127	0	+375	+250	123	375	750

#### FOUR-ROW CYLINDRICAL ROLLER BEARINGS (CYLINDRICAL BORES)

When they are used on backup rolls of four stage rolling mills, the tolerances for roll neck diameters are shown in Table 5. For the fitting between the bearing and chock bore, we recommend G7.

For the fitting of four-row cylindrical roller bearings on the roll necks of other rolling mills, Table 9.2 (Page A84) and Table 9.4 (Page A85) usually apply.

Table 5 Recommended Backup Roll Neck Tolerances

Units :  $\mu\text{m}$

Nominal Bore Diameter $d$		Tolerances for Roll Neck Diameter	
over	incl	high	low
280	355	+0.165	+0.13
355	400	+0.19	+0.15
400	450	+0.22	+0.17
450	500	+0.25	+0.19
500	560	+0.28	+0.21
560	630	+0.32	+0.25
630	710	+0.35	+0.27
710	800	+0.39	+0.31
800	900	+0.44	+0.35
900	1 000	+0.48	+0.39

#### INTERNAL CLEARANCES

##### FOUR-ROW TAPERED ROLLER BEARINGS

The radial internal clearances in four-row tapered roller bearings (cylindrical bores) used on rolling mill roll necks with a loose fit are C2 or often smaller than C2. The NSK standard clearances for four-row tapered roller bearings for roll necks are shown in Table 6. Depending on the operating conditions, special radial clearance selection may become necessary, please contact NSK in such a case.

The internal clearance in four-row tapered roller bearings is padjusted for individual bearing sets, therefore it is necessary to use each part of a given set by observing mating marks when assembling them.

##### FOUR-ROW CYLINDRICAL ROLLER BEARINGS

Please contact NSK regarding internal clearance.

Table 6 Standard Radial Internal Clearances in Four-Row Tapered Roller Bearings (Cylindrical Bores)

Units :  $\mu\text{m}$

Nominal Bore Diameter $d$ (mm)		Radial Internal Clearance	
over	incl	min	max
80	120	25	45
120	180	30	50
180	250	40	60
250	315	50	70
315	400	60	80
400	500	70	90
500	630	80	100
630	800	100	120
800	1 000	120	140



Bore Diameter 100~939.800 mm

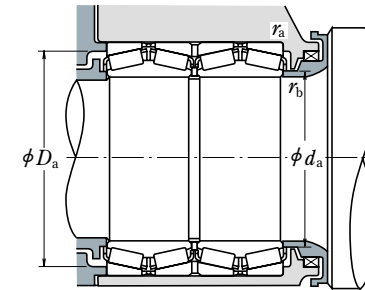
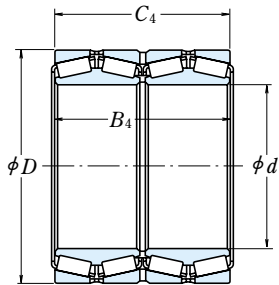

Boundary Dimensions (mm)				Basic Load Ratings (N) (kgf)			
<i>d</i>	<i>D</i>	<i>B<sub>4</sub></i>	<i>C<sub>4</sub></i>	<i>C<sub>r</sub></i>	<i>C<sub>0r</sub></i>	<i>C<sub>r</sub></i>	<i>C<sub>0r</sub></i>
<b>100</b>	140	104	104	320 000	765 000	32 500	78 000
<b>120</b>	170	124	124	475 000	1 080 000	48 000	110 000
<b>135</b>	180	160	160	455 000	1 280 000	46 500	130 000
<b>150</b>	212	155	155	750 000	1 880 000	76 500	192 000
<b>165.100</b>	225.425	165.100	168.275	705 000	2 160 000	72 000	220 000
<b>177.800</b>	247.650	192.088	192.088	950 000	2 570 000	97 000	262 000
<b>190.500</b>	266.700	187.325	188.912	1 010 000	2 870 000	103 000	293 000
<b>206.375</b>	282.575	190.500	190.500	995 000	2 870 000	101 000	292 000
<b>228.600</b>	400.050	296.875	296.875	2 570 000	5 450 000	262 000	555 000
<b>240</b>	338	248	248	1 960 000	5 300 000	199 000	540 000
<b>244.475</b>	327.025	193.675	193.675	1 300 000	3 700 000	132 000	375 000
<b>254.000</b>	358.775	269.875	269.875	2 230 000	6 150 000	227 000	630 000
<b>266.700</b>	355.600	230.188	228.600	1 810 000	5 050 000	185 000	515 000
<b>279.400</b>	393.700	269.875	269.875	2 010 000	5 450 000	205 000	555 000
<b>304.648</b>	438.048	280.990	279.400	2 600 000	6 750 000	265 000	685 000
<b>343.052</b>	457.098	254.000	254.000	2 520 000	7 250 000	256 000	740 000
<b>368.300</b>	523.875	382.588	382.588	5 050 000	14 900 000	515 000	1 520 000
<b>384.175</b>	546.100	400.050	400.050	5 750 000	16 600 000	585 000	1 700 000
<b>406.400</b>	546.100	288.925	288.925	2 960 000	8 550 000	300 000	875 000
<b>415.925</b>	590.550	434.975	434.975	6 450 000	19 500 000	655 000	1 990 000
<b>457.200</b>	596.900	276.225	279.400	3 300 000	10 000 000	335 000	1 020 000
<b>479.425</b>	679.450	495.300	495.300	8 200 000	25 500 000	840 000	2 600 000
<b>482.600</b>	615.950	330.200	330.200	4 100 000	13 800 000	415 000	1 410 000
<b>500</b>	705	515	515	8 350 000	26 600 000	850 000	2 710 000
<b>509.948</b>	654.924	377.000	379.000	4 700 000	16 100 000	480 000	1 640 000
<b>558.800</b>	736.600	409.575	409.575	6 050 000	19 400 000	620 000	1 980 000
<b>571.500</b>	812.800	593.725	593.725	11 700 000	37 000 000	1 200 000	3 800 000
<b>609.600</b>	787.400	361.950	361.950	5 750 000	18 700 000	585 000	1 910 000
<b>635</b>	900	660	660	13 300 000	43 500 000	1 350 000	4 400 000
<b>685.800</b>	876.300	352.425	355.600	6 350 000	22 200 000	645 000	2 270 000
<b>711.200</b>	914.400	317.500	317.500	5 500 000	19 300 000	560 000	1 970 000
<b>749.300</b>	990.600	605.000	605.000	13 000 000	47 000 000	1 330 000	4 800 000
<b>762.000</b>	1 066.800	723.900	736.600	18 000 000	59 500 000	1 840 000	6 050 000
<b>840.000</b>	1 170.000	840.000	840.000	22 200 000	76 000 000	2 260 000	7 750 000
<b>939.800</b>	1 333.500	952.500	952.500	26 900 000	92 000 000	2 740 000	9 400 000

Bearing Numbers	Abutment and Fillet Dimensions (mm)				Mass (kg) approx	Reference Numbers
	<i>d<sub>a</sub></i>	<i>D<sub>a</sub></i>	<i>r<sub>a</sub></i> max	<i>r<sub>b</sub></i> max		
<b>100 KV 895</b>	109	130	2	1.5	4.9	—
<b>120 KV 895</b>	131	158	2	2	8.5	—
<b>135 KV 1802</b>	145	169	1.5	2	11.1	—
<b>150 KV 895</b>	162	196	2	2	17	—
<b>*165 KV 2252</b>	178	209	3.3	0.8	20.2	46791D -720-721D
<b>*177 KV 2452</b>	192	228	3.3	1.5	27.9	67791D -720-721D
<b>*190 KV 2651</b>	204	246	3.3	1.5	32.8	67885D -820-820D
<b>*206 KV 2854</b>	218	261	3.3	0.8	35.2	67986D -920-921D
<b>*228 KV 4051</b>	264	367	3.3	3.3	152	EE 529091D -157-158XD
<b>240 KV 895</b>	257	315	2.5	2.5	68.5	—
<b>*244 KV 3251</b>	260	306	3.3	1.5	44.6	LM 247748D -710-710D
<b>*254 KV 3551</b>	272	335	3.3	1.5	85.6	M 249748DW -710-710D
<b>*266 KV 3552</b>	281	335	3.3	1.5	60.6	—
<b>*279 KV 3951</b>	302	363	6.4	1.5	100	LM 451349D -310-310D
<b>*304 KV 4353</b>	329	407	4.8	3.3	133	EE 135111D -155-156XD
<b>*343 KV 4555</b>	362	430	3.3	1.5	114	M 757448DW -410-410D
<b>*368 KV 5251</b>	396	487	6.4	3.3	274	LM 761649DW -610-610D
<b>*384 KV 5452</b>	417	510	6.4	3.3	309	HM 265049D -010-010D
<b>*406 KV 5455</b>	430	512	6.4	1.5	186	HM 266449D -410-410D
<b>*415 KV 5951</b>	451	550	6.4	3.3	395	LM 767749DW -710-710D
<b>*457 KV 5952</b>	487	566	3.3	1.5	201	M 268749D -710-710D
<b>*479 KV 6751</b>	520	635	6.4	3.3	595	L 770849DW -810-810D
<b>*482 KV 6152</b>	508	582	6.4	3.3	242	M 272749DW -710-710D
<b>500 KV 895</b>	544	657	5	5	654	LM 272249DW -210-210D
<b>*509 KV 6551</b>	536	619	6.4	1.5	312	—
<b>*558 KV 7352</b>	588	697	6.4	3.3	457	LM 377449DW -410-410D
<b>*571 KV 8151</b>	622	755	6.4	3.3	1 020	M 278749DW -710-710D
<b>*609 KV 7851 A</b>	644	745	6.4	3.3	454	EE 649241DW -310-311D
<b>635 KV 9001</b>	695	840	5	4	1 380	—
<b>*685 KV 8751</b>	730	833	6.4	3.3	543	EE 655271DW -345-346D
<b>*711 KV 9151</b>	770	870	6.4	3.3	549	EE 755281DW -360-361D
<b>*749 KV 9951</b>	804	940	6.4	3.3	1 310	LM 283649DW -610-610D
<b>*762 KV 1051</b>	828	996	12.7	5	2 100	—
<b>*840 KV 1151</b>	910	1 095	7	7	2 900	—
<b>*939 KV 1351</b>	1 035	1 245	12.7	4.8	4 380	LM 287849DW -810-810D

Note (\*) Bearings marked \* are inch design.

Remarks 1. For four-row tapered roller bearings not listed above, please contact NSK.

2. Four-row tapered roller bearings are designed for specific applications, when using them, please contact NSK.

Bore Diameter 100~330 mm

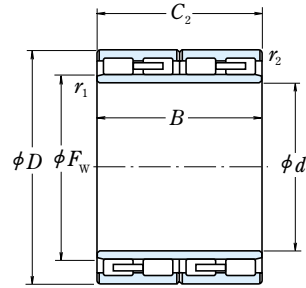

Figure 1

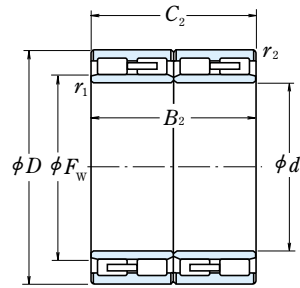

Figure 2

d	Boundary Dimensions (mm)						Basic Load Ratings			
	D	B, B <sub>2</sub>	C <sub>2</sub>	F <sub>w</sub>	r <sub>1</sub> min	r <sub>2</sub> min	C <sub>r</sub> (N)	C <sub>0r</sub> (kgf)	C <sub>r</sub> (N)	C <sub>0r</sub> (kgf)
<b>100</b>	140	104	104	111	1.5	1.1	345 000	820 000	35 000	84 000
<b>145</b>	225	156	156	169	2	2	835 000	1 820 000	85 000	185 000
<b>150</b>	220	150	150	168	2	2	770 000	1 700 000	78 500	174 000
	230	156	156	174	2	2	825 000	1 810 000	84 500	185 000
<b>160</b>	230	130	130	178	2	2	665 000	1 340 000	68 000	136 000
	230	168	168	180	2	2	895 000	2 200 000	91 500	225 000
<b>170</b>	250	168	168	192	2.1	2.1	1 040 000	2 320 000	106 000	237 000
	255	180	180	193	2.1	2.1	1 130 000	2 500 000	115 000	255 000
<b>180</b>	250	156	156	200	2	2	880 000	2 230 000	89 500	227 000
	260	168	168	202	2.1	2.1	990 000	2 300 000	101 000	235 000
<b>190</b>	260	168	168	212	2	2	980 000	2 600 000	100 000	265 000
	270	200	200	212	2.1	2.1	1 260 000	3 100 000	128 000	315 000
<b>200</b>	280	200	200	224	2.1	2.1	1 210 000	3 200 000	123 000	325 000
	290	192	192	226	2.1	2.1	1 220 000	3 000 000	124 000	305 000
<b>220</b>	310	192	192	247	2.1	2.1	1 320 000	3 450 000	134 000	350 000
	310	225	225	245	2.1	2.1	1 500 000	3 900 000	153 000	395 000
	320	210	210	248	2.1	2.1	1 530 000	3 650 000	156 000	375 000
<b>230</b>	330	206	206	260	2.1	2.1	1 510 000	3 900 000	154 000	395 000
	340	260	260	261	3	3	2 050 000	5 100 000	209 000	520 000
<b>240</b>	330	220	220	270	3	3	1 520 000	4 400 000	155 000	445 000
	<b>250</b>	350	220	220	278	3	1 660 000	4 200 000	169 000	430 000
<b>260</b>	370	220	220	292	3	3	1 760 000	4 450 000	179 000	455 000
	380	280	280	294	3	3	2 420 000	6 250 000	247 000	635 000
<b>270</b>	380	230	230	298	2.1	2.1	2 000 000	5 050 000	204 000	515 000
	<b>280</b>	390	220	220	312	3	1 820 000	4 800 000	186 000	490 000
<b>300</b>	400	300	300	328	2	2	2 330 000	6 900 000	238 000	700 000
	420	240	240	332	3	3	2 280 000	5 750 000	233 000	585 000
<b>310</b>	430	240	240	344.5	3	3	2 240 000	5 950 000	228 000	605 000
<b>320</b>	450	240	240	355	3	3	2 320 000	5 750 000	237 000	585 000
<b>330</b>	460	340	340	365	4	4	3 050 000	8 650 000	310 000	880 000

Bearing Numbers	Mass (kg) approx	Figures	Reference Bearing Numbers
<b>100 RV 1401</b>	4	2	—
<b>145 RV 2201</b>	23	1	313924A
<b>150 RV 2201</b>	20	1	—
<b>150 RV 2302</b>	23	1	313891A
<b>160 RV 2301</b>	16	1	—
<b>160 RV 2302</b>	22	1	—
<b>170 RV 2501</b>	27	1	—
<b>170 RV 2503</b>	31	1	—
<b>180 RV 2501</b>	23	1	—
<b>180 RV 2601</b>	29	1	313812
<b>190 RV 2601</b>	26	1	—
<b>190 RV 2701</b>	36	1	314199B
<b>200 RV 2801</b>	38	1	—
<b>200 RV 2901</b>	42	1	313811
<b>220 RV 3101</b>	46	1	—
<b>220 RV 3102</b>	52	1	—
<b>220 RV 3201</b>	56	1	—
<b>230 RV 3301</b>	58	1	313824
<b>230 RV 3401</b>	81	1	—
<b>240 RV 3301</b>	57	1	313921
<b>250 RV 3501</b>	64	1	—
<b>260 RV 3701</b>	76	1	313823
<b>260 RV 3801</b>	107	1	—
<b>270 RV 3801</b>	83	1	—
<b>280 RV 3901</b>	80	1	313822
<b>300 RV 4021</b>	103	2	—
<b>300 RV 4201</b>	101	1	—
<b>310 RV 4301</b>	107	1	—
<b>320 RV 4502</b>	116	1	—
<b>330 RV 4601</b>	174	1	—

- Remarks**
1. For four-row cylindrical roller bearings not listed above, please contact NSK.
  2. Four-row cylindrical roller bearings are designed for specific applications, when using them, please contact NSK.

Bore Diameter 370~920 mm

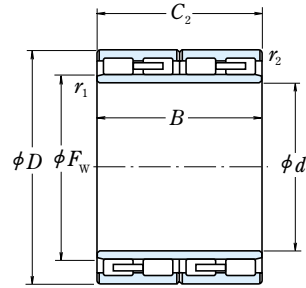

Figure 1

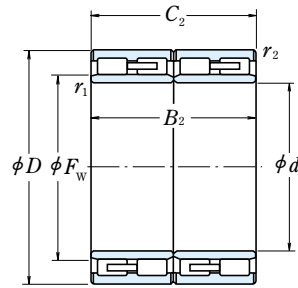

Figure 2

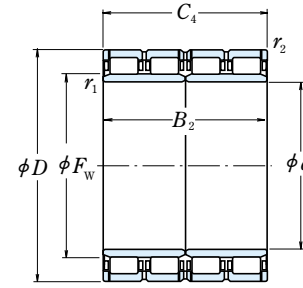

Figure 3

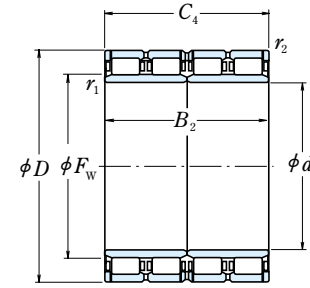

Figure 4

d	Boundary Dimensions (mm)						Basic Load Ratings (N) (kgf)			
	D	B, B <sub>2</sub>	C <sub>2</sub>	F <sub>w</sub>	r <sub>1</sub> min	r <sub>2</sub> min	C <sub>r</sub>	C <sub>0r</sub>	C <sub>r</sub>	C <sub>0r</sub>
<b>370</b>	540	400	400	415	4	4	4 500 000	12 000 000	460 000	1 230 000
<b>380</b>	540	400	400	424	5	5	4 300 000	12 000 000	440 000	1 220 000
<b>390</b>	550	400	400	434	5	5	4 400 000	12 400 000	450 000	1 260 000
<b>400</b>	560	410	410	445	5	2	5 600 000	16 500 000	575 000	1 680 000
<b>430</b>	591	420	420	476	4	4	4 450 000	13 400 000	455 000	1 370 000
<b>440</b>	620	450	450	490	4	4	6 350 000	19 000 000	650 000	1 940 000
<b>450</b>	630	450	450	500	4	4	5 950 000	17 500 000	605 000	1 780 000
<b>460</b>	670	500	500	522	6	6	7 650 000	22 700 000	780 000	2 320 000
<b>480</b>	680	500	500	534	5	5	7 700 000	23 100 000	785 000	2 360 000
<b>500</b>	690	510	510	552	5	5	7 750 000	24 600 000	790 000	2 500 000
	700	515	515	554	5	5	7 800 000	23 800 000	800 000	2 430 000
	720	530	530	560	6	6	8 550 000	25 300 000	870 000	2 580 000
<b>520</b>	735	535	535	574.5	5	5	8 900 000	26 300 000	910 000	2 680 000
<b>530</b>	780	570	570	601	6	6	10 100 000	29 200 000	1 030 000	2 980 000
<b>570</b>	815	594	594	628	6	6	11 700 000	33 500 000	1 190 000	3 450 000
<b>610</b>	870	660	660	680	6	6	13 200 000	41 500 000	1 340 000	4 250 000
<b>650</b>	920	690	690	723	7.5	7.5	14 200 000	45 000 000	1 450 000	4 600 000
<b>690</b>	980	715	715	767.5	7.5	7.5	15 300 000	48 000 000	1 560 000	4 900 000
<b>700</b>	930	620	620	763	6	6	11 100 000	38 000 000	1 130 000	3 900 000
	980	700	700	774	6	6	15 300 000	49 000 000	1 560 000	5 000 000
<b>725</b>	1 000	700	700	796	6	6	15 600 000	51 000 000	1 590 000	5 200 000
<b>760</b>	1 080	805	790	845	6	6	19 000 000	61 000 000	1 940 000	6 200 000
<b>800</b>	1 080	750	750	880	6	6	16 000 000	56 500 000	1 630 000	5 750 000
<b>820</b>	1 160	840	840	911	7.5	7.5	21 900 000	71 500 000	2 230 000	7 300 000
	1 100	745	720	892	6	3	16 900 000	58 500 000	1 720 000	6 000 000
<b>850</b>	1 180	850	850	940	7.5	7.5	21 100 000	72 000 000	2 150 000	7 350 000
<b>860</b>	1 130	670	670	934	6	6	15 700 000	56 500 000	1 600 000	5 800 000
	1 160	735	710	940	7.5	4	17 500 000	60 000 000	1 780 000	6 100 000
<b>900</b>	1 230	895	870	985	7.5	7.5	22 100 000	76 000 000	2 250 000	7 750 000
<b>920</b>	1 280	865	850	1 015	7.5	7.5	24 000 000	80 000 000	2 450 000	8 150 000

**Remarks** 1. For four-row cylindrical roller bearings not listed above, please contact NSK.  
2. Four-row cylindrical roller bearings are designed for specific applications, when using them, please contact NSK.

Bearing Numbers	Mass (kg) approx	Figures	Reference Bearing Numbers
<b>380 RV 5401</b>	280	1 <sup>(1)</sup>	—
<b>390 RV 5521</b>	303	2 <sup>(1)</sup>	—
<b>400 RV 5611</b>	315	3	313015
<b>430 RV 5921</b>	347	2	—
<b>440 RV 6221</b>	430	2	—
<b>450 RV 6321</b>	440	2	—
<b>460 RV 6721</b>	596	2 <sup>(1)</sup>	—
<b>480 RV 6811</b>	610	3	—
<b>500 RV 6921</b>	580	2 <sup>(1)</sup>	—
<b>500 RV 7021</b>	622	2 <sup>(1)</sup>	—
<b>500 RV 7211</b>	782	3	—
<b>520 RV 7331</b>	750	4	—
<b>530 RV 7811</b>	960	3	—
<b>570 RV 8111</b>	960	3	—
<b>610 RV 8711</b>	1 330	3	—
<b>650 RV 9211</b>	1 520	3	—
<b>690 RV 9831</b>	1 790	4	—
<b>700 RV 9311</b>	1 200	3	—
<b>700 RV 9821</b>	1 720	2 <sup>(1)</sup>	—
<b>725 RV 1011</b>	1 670	3	—
<b>760 RV 1032</b>	2 430	4	—
<b>800 RV 1032</b>	2 050	4	—
<b>820 RV 1121</b>	2 900	2 <sup>(1)</sup>	—
<b>820 RV 1132</b>	2 000	4	—
<b>850 RV 1111</b>	2 850	3	—
<b>860 RV 1132</b>	1 780	4	—
<b>860 RV 1133</b>	2 200	4	—
<b>900 RV 1211</b>	3 200	3	—
<b>920 RV 1211</b>	3 510	3	—

**Note** <sup>(1)</sup> Oil holes and oil grooves are provided at the center of outer rings.

## Railway Rolling Stock Bearings

Railway rolling stock bearings are important components of rolling stocks that require high reliability.

The main bearings consist of axle bearings that are mounted at both ends of axle and support the entire weight of the rolling stock. Additionally, there are railway traction motor bearings that are used for the motor that drives the axle; and gear unit bearings that transfer the power from the motor to the axle. NSK has designed and manufactured specific bearings for these very applications.

### Types and Features

#### Axle Bearings

- Axle bearings consist of the following types of bearings to meet operator demands for high-speed capability of rolling stock, weight reductions, and minimal maintenance and inspection requirements:
  - Cylindrical roller bearings with a thrust collar (oil bath lubrication, grease lubrication)
  - Tapered roller bearings (oil bath lubrication)
  - RCC Bearings (sealed-clean rotating end cap cylindrical roller bearings) (grease lubrication)
  - RCT bearings (sealed-clean rotating end cap tapered roller bearings) (grease lubrication)
- NSK has been approved by AAR (Association of American Railroads).

#### Traction Motor Bearings

- Bearings for inverter controlled AC motors are specially designed to meet high-speed specifications and requirements for ensuring dimensional stability. NSK recommends long-life grease for these bearings.
- NSK offers the following bearings as a measure against electric erosion, which occurs when electric current is allowed to flow through the motor bearings:
  - Ceramic-insulated bearings (ceramic-coated bearings) and PPS-insulated bearings
- High capacity bearings also available for locomotive-type large traction motors

#### Gear Unit Bearings

- These bearings are designed to meet high-speed specifications and offer excellent seizure resistance.
- A reinforced cage has been adopted for these bearings.

### Specified catalogs

- Bearings for Railway Rolling Stock CAT No. E1156
- Axle Bearings for Railway Rolling Stock (Cylindrical Roller Bearings) CAT No. E1239
- Axle Bearings for Railway Rolling Stock (Spherical Roller Bearings) CAT No. E1240
- Bearings for Traction Motors CAT No. E1241

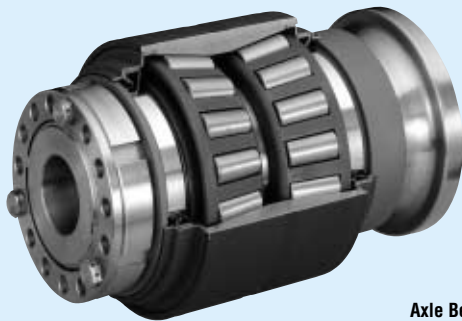

Axle Bearings

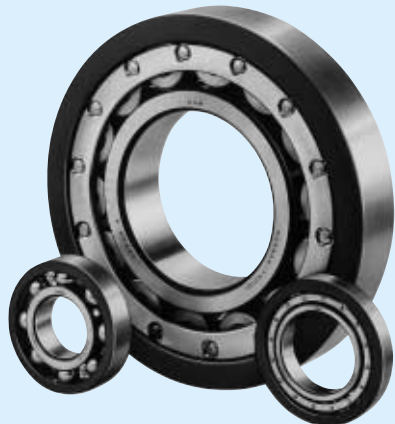
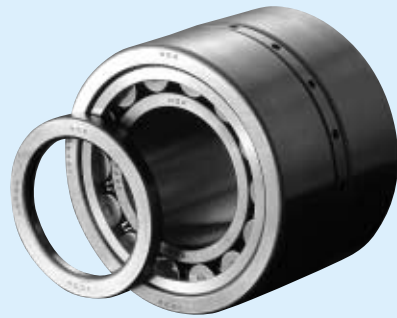

Traction Motor Bearings



Gear Unit Bearings

## STEEL BALLS AND ROLLERS

**STEEL BALLS  
FOR BALL BEARINGS**

Nominal Diameter 0.3~114.3mm ....Pages B344~B345

**CYLINDRICAL ROLLERS  
FOR ROLLER BEARINGS**

Nominal Diameter 3~80mm .....Pages B346~B347

**LONG CYLINDRICAL ROLLERS  
FOR ROLLER BEARINGS**

Nominal Diameter 5.5~15mm .....Pages B348~B349

**NEEDLE ROLLERS  
FOR ROLLER BEARINGS**

Nominal Diameter 1~5mm .....Pages B350~B351

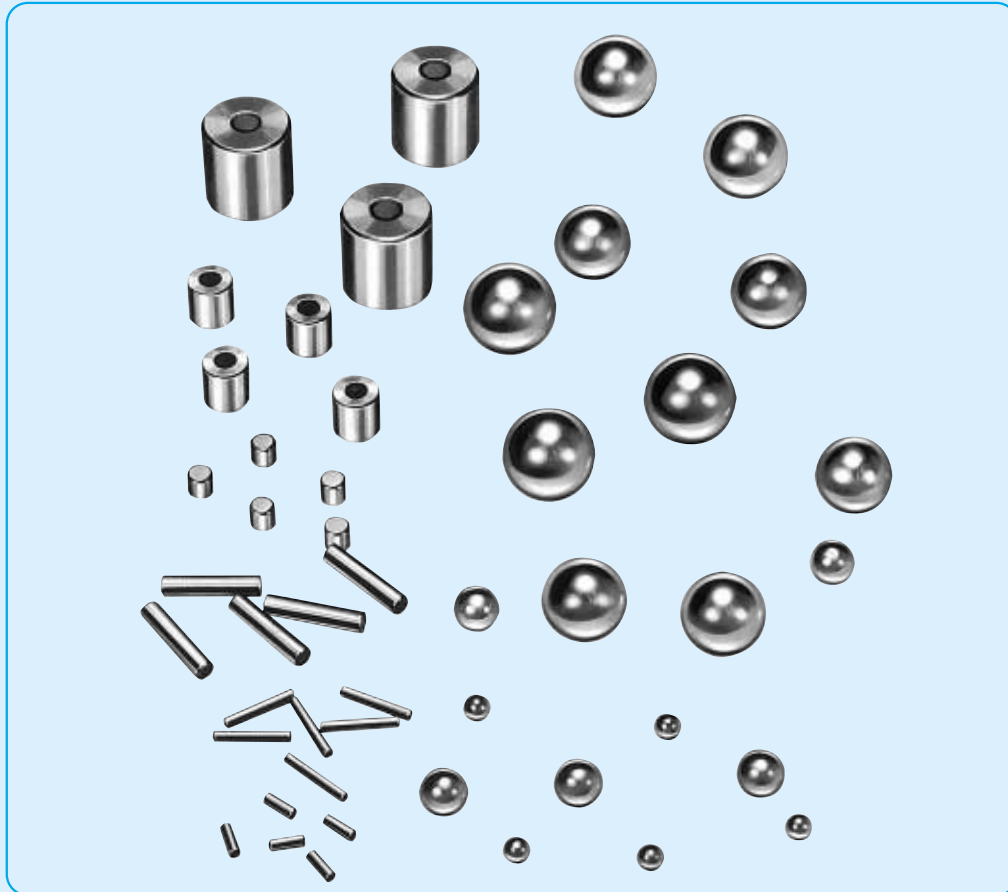

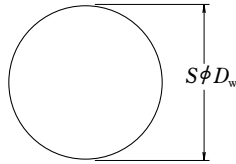

Nominal Size, Basic Diameters, and Mass

Nominal Size		Basic Diameter Dw (mm)	Mass (kg) per 10000 pcs approx	Nominal Size		Basic Diameter Dw (mm)	Mass (kg) per 1000 pcs approx	Nominal Size		Basic Diameter Dw (mm)	Mass (kg) per 10 pcs approx
Metric	Inch			Metric	Inch			Metric	Inch		
0.3mm		0.30000	0.0011	10 mm	3/8	9.52500	3.523	30mm	30.00000	1.101	
0.4mm		0.40000	0.0026			10.00000	4.076	1 3/16	30.16250	1.119	
0.5mm		0.50000	0.0051	13/32		10.31875	4.479	1 1/4	31.75000	1.305	
0.6mm	0.025	0.60000	0.0088	11 mm	7/16	11.00000	5.425	32mm	32.00000	1.336	
		0.63500	0.0104			11.11250	5.594	1 5/16	33.33750	1.510	
0.7mm		0.70000	0.0140	11.5mm		11.50000	6.199	34mm	34.00000	1.602	
	1/32	0.79375	0.0204		15/32	11.90625	6.880	1 3/8	34.92500	1.736	
0.8mm		0.80000	0.0209	12 mm		12.00000	7.044	35mm	35.00000	1.748	
1 mm		1.00000	0.0408	1/2		12.70000	8.350	36mm	36.00000	1.902	
	3/64	1.19062	0.0688	13 mm		13.00000	8.955	1 7/16	36.51250	1.984	
1.2mm		1.20000	0.0704	14 mm	17/32	13.49375	10.02	38mm	38.00000	2.237	
1.5mm		1.50000	0.1376		1/2	14.00000	11.19	1 1/2	38.10000	2.254	
	1/16	1.58750	0.1631	15 mm	9/16	14.28750	11.89	1 9/16	39.68750	2.548	
2 mm	5/64	1.98438	0.3185			15.00000	13.76	40mm	40.00000	2.609	
		2.00000	0.3261	16 mm	19/32	15.08125	13.98	1 5/8	41.27500	2.866	
2.5mm	3/32	2.38125	0.5504		5/8	15.87500	16.31	1 11/16	42.86250	3.210	
		2.50000	0.6369	16 mm		16.00000	16.70	1 3/4	44.45000	3.580	
	7/64	2.77812	0.8740	21/32		16.66875	18.88	45mm	45.00000	3.714	
3 mm		3.00000	1.101	17 mm		17.00000	20.03	1 13/16	46.03750	3.977	
	1/8	3.17500	1.305		11/16	17.46250	21.71	1 7/8	47.62500	4.403	
3.5mm		3.50000	1.748	18 mm		18.00000	23.77	1 15/16	49.21250	4.858	
	9/64	3.57188	1.858	19 mm	23/32	18.25625	24.80	50mm	50.00000	5.095	
4 mm	5/32	3.96875	2.548			19.00000	27.96	2	50.80000	5.344	
		4.00000	2.609	3/4		19.05000	28.18	2 1/8	53.97500	6.410	
4.5mm		4.50000	3.714	20 mm	25/32	19.84375	31.85	55mm	55.00000	6.782	
	3/16	4.76250	4.403			20.00000	32.61	2 1/4	57.15000	7.609	
5 mm		5.00000	5.095	20 mm	13/16	20.63750	35.83	60mm	60.00000	8.805	
5.5mm		5.50000	6.782	21 mm		21.00000	37.75	2 3/8	60.32500	8.948	
	7/32	5.55625	7.016	22 mm	27/32	21.43125	40.12	2 1/2	63.50000	10.44	
	15/64	5.95312	8.600			22.00000	43.40	65mm	65.00000	11.19	
6 mm		6.00000	8.805	23 mm	7/8	22.22500	44.75	2 5/8	66.67500	12.08	
	1/4	6.35000	10.44			23.00000	49.60	2 3/4	69.85000	13.89	
6.5mm		6.50000	11.19	23 mm	29/32	23.01875	49.72	2 7/8	73.02500	15.87	
7 mm	17/64	6.74688	12.52	24 mm	15/16	23.81250	55.04	3	76.20000	18.04	
	9/32	7.00000	13.98			24.00000	56.35	3 1/4	82.55000	22.93	
		7.14375	14.86	24 mm	31/32	24.60625	60.73	3 1/2	88.90000	28.64	
7.5mm		7.50000	17.20	25 mm		25.00000	63.69	3 3/4	95.25000	35.23	
	5/16	7.93750	20.38		1	25.40000	66.80	4	101.60000	42.75	
8 mm		8.00000	20.87	26 mm		26.00000	71.64	4 1/4	107.95000	51.28	
8.5mm		8.50000	25.03	28 mm	1 1/16	26.98750	80.12	4 1/2	114.30000	60.87	
	11/32	8.73125	27.13			28.00000	89.48				
9 mm		9.00000	29.72	1 1/8		28.57500	95.11				

Application, Nominal Size, Tolerances, Roughness, and Gauges

Units : μm

Class	Nominal Size		Tolerances			Gauges		
			Variation in Dia. max	Sphericity max	Roughness Ra max	Diameter Difference per Lot max	Gauge Interval	Gauge
	Metric	Inch						
3	0.3mm~12mm	0.025~ 1/2	0.08	0.08	0.012	0.13	0.5	- 5, , - 0.5, 0, + 0.5, , + 5
5	0.3mm~12mm	0.025~ 1/2	0.13	0.13	0.02	0.25	1	- 5, , - 1, 0, + 1, , + 5
10	0.3mm~25mm	0.025~1	0.25	0.25	0.025	0.5	1	- 9, , - 1, 0, + 1, , + 9
16	0.3mm~25mm	0.025~1	0.4	0.4	0.032	0.8	2	-10, , - 2, 0, + 2, , +10
20	0.3mm~38mm	0.025~1 1/2	0.5	0.5	0.04	1	2	-10, , - 2, 0, + 2, , +10
28	0.3mm~38mm	0.025~1 1/2	0.7	0.7	0.05	1.4	2	-12, , - 2, 0, + 2, , +12
40	0.3mm~50mm	0.025~2	1	1	0.08	2	4	-16, , - 4, 0, + 4, , +16
60	0.3mm~65mm	0.025~3	1.5	1.5	0.095	3	5	-25, , - 5, 0, + 5, , +25
100	0.3mm~65mm	0.025~4 1/2	2.5	2.5	0.125	5	10	-40, , -10, 0, +10, , +40
200	0.3mm~65mm	0.025~4 1/2	5	5	0.2	10	15	-60, , -15, 0, +15, , +60

Hardness

Nominal Size		Hardness	
Metric	Inch	HV	HRC
0.3mm~ 3mm	0.025~ 7/64	772~900	(63~67) <sup>(1)</sup>
3.5mm~30mm	1/8~1 1/8	—	62~67
32 mm~65mm	1 3/16~4 1/2	—	61~67

Note <sup>(1)</sup> Values in ( ) are converted values for reference.



Tolerances for Cylindrical Roller Chamfers

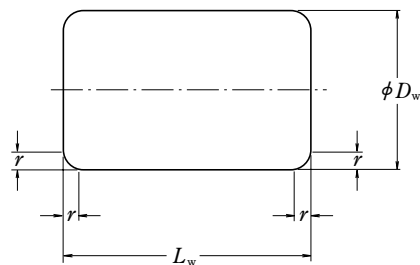

Units : mm

min	max
0.1	0.3
0.2	0.5
0.3	0.8
0.5	1.2
0.6	1.5
0.7	1.7
1	2.2 <sup>(1)</sup>
1.5	3.5
2	4

Note <sup>(1)</sup> If  $D_w$  exceeds 40mm,  $r$  (max) is 2.7mm.

Units : mm

Nominal Size	$D_w$	$L_w$	$r$ min	Mass (kg) per 100 pcs approx
3 × 3	3	3	0.1	0.016
3 × 5	3	5	0.1	0.027
3.5 × 5	3.5	5	0.2	0.037
4 × 4	4	4	0.2	0.039
4 × 6	4	6	0.2	0.058
4 × 8	4	8	0.2	0.078
4.5 × 4.5	4.5	4.5	0.2	0.055
4.5 × 6	4.5	6	0.2	0.073
5 × 5	5	5	0.2	0.075
5 × 8	5	8	0.2	0.121
5 × 10	5	10	0.2	0.152
5.5 × 5.5	5.5	5.5	0.2	0.10
5.5 × 8	5.5	8	0.2	0.146
6 × 6	6	6	0.2	0.13
6 × 8	6	8	0.2	0.178
6 × 12	6	12	0.2	0.261
6.5 × 6.5	6.5	6.5	0.3	0.166
6.5 × 9	6.5	9	0.3	0.23
7 × 7	7	7	0.3	0.206
7 × 10	7	10	0.3	0.296
7 × 14	7	14	0.3	0.415
7.5 × 7.5	7.5	7.5	0.3	0.254
7.5 × 11	7.5	11	0.3	0.375
8 × 8	8	8	0.3	0.31
8 × 12	8	12	0.3	0.465
9 × 9	9	9	0.3	0.44
9 × 14	9	14	0.3	0.68
10 × 10	10	10	0.3	0.60
10 × 14	10	14	0.3	0.85
11 × 11	11	11	0.3	0.81
11 × 15	11	15	0.3	1.1
12 × 12	12	12	0.3	1.04
12 × 18	12	18	0.3	1.57
13 × 13	13	13	0.3	1.33
13 × 20	13	20	0.3	2.04
14 × 14	14	14	0.3	1.66
14 × 20	14	20	0.3	2.38

Units : mm

Nominal Size	$D_w$	$L_w$	$r$ min	Mass (kg) per 100 pcs approx
15 × 15	15	15	0.5	2.04
15 × 22	15	22	0.5	3.0
16 × 16	16	16	0.5	2.48
16 × 24	16	24	0.5	3.75
17 × 17	17	17	0.5	2.97
17 × 24	17	24	0.5	4.2
18 × 18	18	18	0.5	3.55
18 × 26	18	26	0.5	5.1
19 × 19	19	19	0.6	4.16
19 × 28	19	28	0.6	6.1
20 × 20	20	20	0.6	4.85
20 × 30	20	30	0.6	7.3
21 × 21	21	21	0.6	5.6
21 × 30	21	30	0.6	8.0
22 × 22	22	22	0.6	6.4
22 × 34	22	34	0.6	10
23 × 23	23	23	0.6	7.4
23 × 34	23	34	0.6	11.2
24 × 24	24	24	0.6	8.4
24 × 36	24	36	0.6	12.6
25 × 25	25	25	0.7	9.5
25 × 36	25	36	0.7	13.7
26 × 26	26	26	0.7	10.7
26 × 40	26	40	0.7	16.4
28 × 28	28	28	0.7	13.3
28 × 44	28	44	0.7	21
30 × 30	30	30	0.7	16.3
30 × 48	30	48	0.7	26.2
32 × 32	32	32	1	19.9
32 × 52	32	52	1	32.5
34 × 34	34	34	1	23.9
34 × 55	34	55	1	38.5
36 × 36	36	36	1	28.3
36 × 58	36	58	1	45.5
38 × 38	38	38	1	33.5
38 × 62	38	62	1	55
40 × 40	40	40	1	39
40 × 65	40	65	1	63

Units : mm

Nominal Size	$D_w$	$L_w$	$r$ min	Mass (kg) per 100 pcs approx
42 × 42	42	42	1	45
45 × 45	45	45	1	55.5
48 × 48	48	48	1	67
50 × 50	50	50	1	76
52 × 52	52	52	1.5	85
54 × 54	54	54	1.5	95.5
56 × 56	56	56	1.5	107
60 × 60	60	60	1.5	131
64 × 64	64	64	1.5	159
68 × 68	68	68	1.5	191
75 × 75	75	75	2	256
80 × 80	80	80	2	310

Accuracy of Cylindrical Rollers

Units :  $\mu\text{m}$

Class	$D_w$ (mm)		Out-of-Roundness <sup>(1)</sup> $\Delta R$ max	Single Plane Mean Roller Diameter Variation <sup>(2)</sup> $VD_{Wmp}$ max	Roller Gauge Lot Diameter Variation <sup>(1)</sup> $VD_{WL}$ max	Length Deviation <sup>(3)</sup> $\Delta L_{Ws}$		Roller Gauge Lot Length Variation $VL_{WL}$ max	End Face Runout $S_w$ max
	over	incl				high	low <sup>(4)</sup>		
1	3	18	0.5	0.8	1	+10	- [ (IT9) - 10]	5	3
1A	3	30	0.7	1	1.5	+10	- [ (IT9) - 10]	7	5
2	3	50	1	1.5	2	+10	- [ (IT9) - 10]	10	6
2A	10	80	1.3	2	2.5	+10	- [ (IT9) - 10]	13	8
3	18	80	1.5	3	3	+10	- [ (IT9) - 10]	15	10
5	30	80	2.5	4	5	+10	- [ (IT9) - 10]	25	15

Notes <sup>(1)</sup> Applicable to roller center (length direction).

<sup>(2)</sup> Applicable to cylindrical outside surface.

<sup>(3)</sup> To find the IT9 standard tolerance according to the  $L_w$  size classification, refer to the IT9 column of the Appendix Table 11 on Page C22.

<sup>(4)</sup> The value for low of length deviation is subtracted 10 $\mu\text{m}$  from the value of the standard tolerance for each roller length.



**Remarks** The figure shows an example of a flat-end long cylindrical roller.

**Tolerances for Long Cylindrical Roller Chamfers**

Units : mm

min		max	
0.2		0.5	
0.3		0.8	
0.5		1.2	

Units : mm

Nominal Size	$D_w$	$L_w$	$r^{(1)}$ min	Mass (kg) per 100 pcs approx
<b>5.5×18</b>	5.5	18	0.2	0.333
<b>5.5×22.4</b>	5.5	22.4	0.2	0.414
<b>5.5×28</b>	5.5	28	0.2	0.518
<b>6 ×20</b>	6	20	0.2	0.44
<b>6 ×25</b>	6	25	0.2	0.55
<b>6 ×31.5</b>	6	31.5	0.2	0.693
<b>6 ×40</b>	6	40	0.2	0.88
<b>6 ×50</b>	6	50	0.2	1.1
<b>6.5×20</b>	6.5	20	0.3	0.516
<b>6.5×25</b>	6.5	25	0.3	0.645
<b>6.5×31.5</b>	6.5	31.5	0.3	0.813
<b>7 ×22.4</b>	7	22.4	0.3	0.671
<b>7 ×28</b>	7	28	0.3	0.838
<b>7 ×35.5</b>	7	35.5	0.3	1.06
<b>7 ×45</b>	7	45	0.3	1.35
<b>7 ×56</b>	7	56	0.3	1.68
<b>7.5×31.5</b>	7.5	31.5	0.3	1.08
<b>7.5×40</b>	7.5	40	0.3	1.38

Units : mm

Nominal Size	$D_w$	$L_w$	$r^{(1)}$ min	Mass (kg) per 100 pcs approx
<b>8 ×25</b>	8	25	0.3	0.978
<b>8 ×31.5</b>	8	31.5	0.3	1.23
<b>8 ×40</b>	8	40	0.3	1.56
<b>8 ×50</b>	8	50	0.3	1.96
<b>8 ×63</b>	8	63	0.3	2.46
<b>9 ×28</b>	9	28	0.3	1.39
<b>9 ×35.5</b>	9	35.5	0.3	1.76
<b>9 ×45</b>	9	45	0.3	2.23
<b>9 ×56</b>	9	56	0.3	2.77
<b>10×31.5</b>	10	31.5	0.3	1.93
<b>10×40</b>	10	40	0.3	2.44
<b>10×50</b>	10	50	0.3	3.06
<b>10×63</b>	10	63	0.3	3.85
<b>12×40</b>	12	40	0.3	3.52
<b>12×50</b>	12	50	0.3	4.4
<b>12×63</b>	12	63	0.3	5.54
<b>15×45</b>	15	45	0.5	6.16
<b>15×56</b>	15	56	0.5	7.68
<b>15×71</b>	15	71	0.5	9.74
<b>15×90</b>	15	90	0.5	12.4

**Note** <sup>(1)</sup> Only for flat-end rollers.

**Accuracy of Long Cylindrical Rollers**

Units :  $\mu\text{m}$

Class	Out-of-Roundness <sup>(1)</sup> $\Delta R$ max	Single Plane Mean Roller Diameter Variation <sup>(2)</sup> $VD_{Wmp}$ max	Roller Gauge Lot Diameter Variation <sup>(1)</sup> $VD_{WL}$ max	Length Deviation <sup>(2)</sup> $\Delta L_{Ws}$
3	1.5	3	3	h12
5	2	5	5	h12

**Notes** <sup>(1)</sup> Applicable to roller center (length direction).  
<sup>(2)</sup> Classified by  $L_w$ . Refer to Tolerance for Length Deviation.  
<sup>(3)</sup> Applicable to cylindrical outside surface.

**Tolerance for Length Deviation**

Units : mm

Length		h12		h13	
over	incl	high	low	high	low
3	6	—	—	0	- 0.18
6	10	—	—	0	- 0.22
10	18	—	—	0	- 0.27

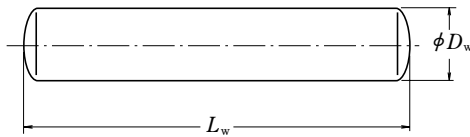

Spherical-end Type

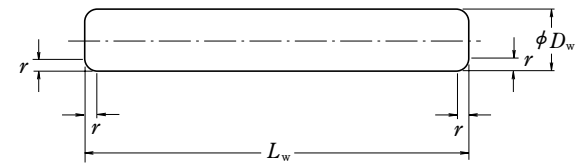

Flat-end Type

Units : mm

Units : mm

Nominal Size	D <sub>w</sub>	L <sub>w</sub>	r <sup>(1)</sup> min	Mass (kg) per 1000 pcs approx	Nominal Size	D <sub>w</sub>	L <sub>w</sub>	r <sup>(1)</sup> min	Mass (kg) per 1000 pcs approx
1 × 5.8	1	5.8	0.1	0.035	3.5×19.8	3.5	19.8	0.1	1.50
1 × 6.8	1	6.8	0.1	0.042	3.5×21.8	3.5	21.8	0.1	1.65
1 × 7.8	1	7.8	0.1	0.048	3.5×23.8	3.5	23.8	0.1	1.80
1 × 9.8	1	9.8	0.1	0.060	3.5×25.8	3.5	25.8	0.1	1.95
1.5 × 5.8	1.5	5.8	0.1	0.080	3.5×27.8	3.5	27.8	0.1	2.10
1.5 × 6.8	1.5	6.8	0.1	0.093	3.5×29.8	3.5	29.8	0.1	2.25
1.5 × 7.8	1.5	7.8	0.1	0.105	3.5×31.8	3.5	31.8	0.1	2.40
1.5 × 9.8	1.5	9.8	0.1	0.135	3.5×34.8	3.5	34.8	0.1	2.60
1.5×11.8	1.5	11.8	0.1	0.160	4 ×13.8	4	13.8	0.1	1.35
1.5×13.8	1.5	13.8	0.1	0.190	4 ×15.8	4	15.8	0.1	1.55
2 × 6.8	2	6.8	0.1	0.165	4 ×17.8	4	17.8	0.1	1.75
2 × 7.8	2	7.8	0.1	0.190	4 ×19.8	4	19.8	0.1	1.95
2 × 9.8	2	9.8	0.1	0.240	4 ×21.8	4	21.8	0.1	2.15
2 ×11.8	2	11.8	0.1	0.290	4 ×23.8	4	23.8	0.1	2.35
2 ×13.8	2	13.8	0.1	0.335	4 ×25.8	4	25.8	0.1	2.55
2 ×15.8	2	15.8	0.1	0.385	4 ×27.8	4	27.8	0.1	2.70
2 ×17.8	2	17.8	0.1	0.435	4 ×29.8	4	29.8	0.1	2.90
2 ×19.8	2	19.8	0.1	0.485	4 ×31.8	4	31.8	0.1	3.10
2.5 × 7.8	2.5	7.8	0.1	0.300	4 ×34.8	4	34.8	0.1	3.40
2.5 × 9.8	2.5	9.8	0.1	0.375	4 ×37.8	4	37.8	0.1	3.70
2.5×11.8	2.5	11.8	0.1	0.450	4 ×39.8	4	39.8	0.1	3.90
2.5×13.8	2.5	13.8	0.1	0.525	4.5×17.8	4.5	17.8	0.1	2.20
2.5×15.8	2.5	15.8	0.1	0.605	4.5×19.8	4.5	19.8	0.1	2.45
2.5×17.8	2.5	17.8	0.1	0.680	4.5×21.8	4.5	21.8	0.1	2.70
2.5×19.8	2.5	19.8	0.1	0.755	4.5×23.8	4.5	23.8	0.1	2.95
2.5×21.8	2.5	21.8	0.1	0.835	4.5×25.8	4.5	25.8	0.1	3.20
2.5×23.8	2.5	23.8	0.1	0.910	4.5×27.8	4.5	27.8	0.1	3.45
3 × 9.8	3	9.8	0.1	0.540	4.5×29.8	4.5	29.8	0.1	3.70
3 ×11.8	3	11.8	0.1	0.650	4.5×31.8	4.5	31.8	0.1	3.95
3 ×13.8	3	13.8	0.1	0.760	4.5×34.8	4.5	34.8	0.1	4.30
3 ×15.8	3	15.8	0.1	0.870	4.5×37.8	4.5	37.8	0.1	4.70
3 ×17.8	3	17.8	0.1	0.980	4.5×39.8	4.5	39.8	0.1	4.90
3 ×19.8	3	19.8	0.1	1.10	5 ×19.8	5	19.8	0.1	3.00
3 ×21.8	3	21.8	0.1	1.20	5 ×21.8	5	21.8	0.1	3.35
3 ×23.8	3	23.8	0.1	1.30	5 ×23.8	5	23.8	0.1	3.65
3 ×25.8	3	25.8	0.1	1.40	5 ×25.8	5	25.8	0.1	3.95
3 ×27.8	3	27.8	0.1	1.55	5 ×27.8	5	27.8	0.1	4.25
3 ×29.8	3	29.8	0.1	1.65	5 ×29.8	5	29.8	0.1	4.55
3.5×11.8	3.5	11.8	0.1	0.885	5 ×31.8	5	31.8	0.1	4.85
3.5×13.8	3.5	13.8	0.1	1.05	5 ×34.8	5	34.8	0.1	5.30
3.5×15.8	3.5	15.8	0.1	1.20	5 ×37.8	5	37.8	0.1	5.75
3.5×17.8	3.5	17.8	0.1	1.35	5 ×39.8	5	39.8	0.1	6.10
					5 ×49.8	5	49.8	0.1	7.60

Note <sup>(1)</sup> Only for flat-end rollers.

Remarks 1. The figure shows a spherical-end type and a flat-end type.

2. The radius R of the spherical-end type is bounded by the following range:

Minimum: D<sub>w</sub>/2

Maximum: L<sub>w</sub>/2

Tolerances for Needle Roller Chamfers

Units : mm

D <sub>w</sub>		r min	r max
over	incl		
—	1	0.1	0.4
1	3	0.1	0.6
3	5	0.1	0.9

Remarks Only for flat-end needle rollers.

Accuracy of Needle Rollers

Units : μm

Class	Single Plane Mean Roller Diameter Variation <sup>(1)</sup> VD <sub>WP</sub> max	Out-of- Roundness <sup>(1)</sup> ΔR max	Roller Gauge Lot Diameter Variation <sup>(1)</sup> VD <sub>WL</sub> max	Length Deviation <sup>(2)</sup> ΔL <sub>Ws</sub>
2	1	1	2	h13
3	1.5	1.5	3	h13
5	2	2.5	5	h13

Notes <sup>(1)</sup> Applicable to roller center (length direction).

<sup>(2)</sup> Classified by L<sub>w</sub>. Refer to Tolerance for Length Deviation in Page B349.

Remarks The actual diameter at any place along the entire length should not exceed the following figures compared to the actual maximum diameter at the roller center (length direction).

Class2: 0.5μm

Class3: 0.8μm

Class5: 1.0μm

## ACCESSORIES FOR ROLLING BEARINGS

<b>ADAPTERS FOR ROLLING BEARINGS</b>	Shaft Diameter 17~470mm .....Pages B354~B361
<b>WITHDRAWAL SLEEVES FOR ROLLING BEARINGS</b>	Shaft Diameter 35~480mm .....Pages B362~B367
<b>NUTS FOR ROLLING BEARINGS</b>	.....Pages B368~B372
<b>STOPPERS FOR ROLLING BEARINGS</b>	.....Page B373
<b>WASHERS FOR ROLLING BEARINGS</b>	.....Pages B374~B375

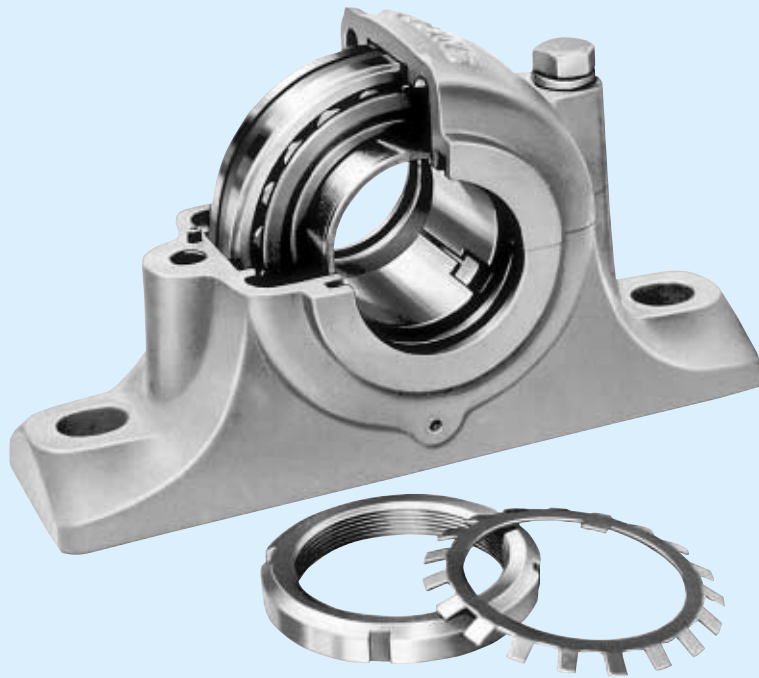

Shaft Diameter 17~40 mm

Shaft Diameter 45~60 mm

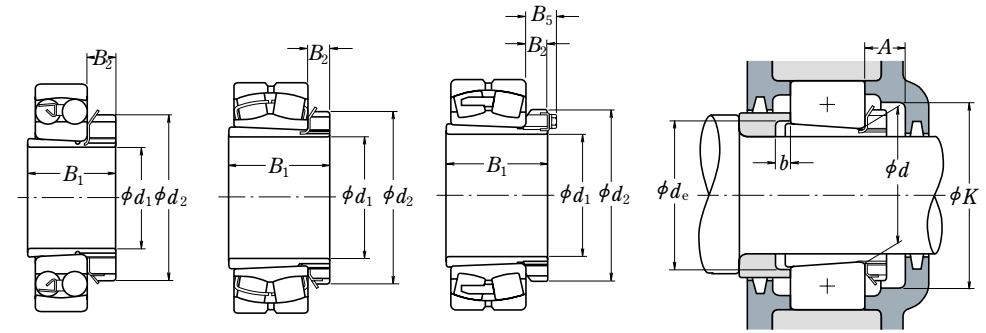
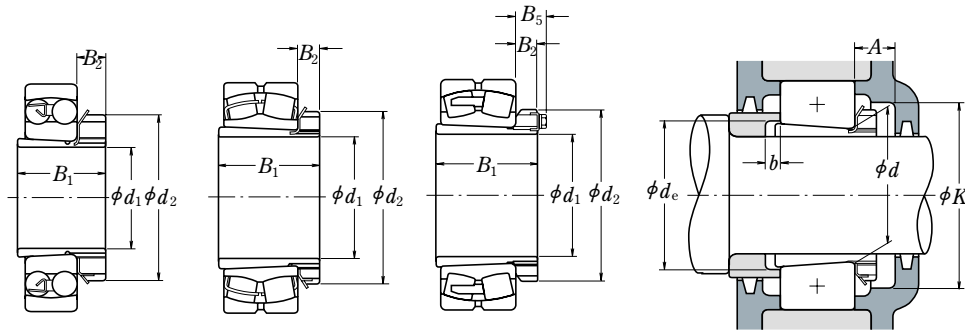

Shaft Diameter (mm) $d_1$	Nominal Bearing Bore Dia. (mm) $d$	Nominal Numbers				Dimensions (mm)				Adapter Sleeve Numbers	Abutment Dimensions (mm)				Mass (kg) approx
		Applicable Bearings				$B_1$	$d_2$	$B_2$	$B_5$		$A$ min	$K$ min	$d_e$ min	$b$ min	
17	20	1204K	+ H 204X	24	32	7	—	A 204X	14	39	23	5	0.045		
	20	2204K	+ H 304X	28	32	7	—	A 304X	14	39	24	5	0.045		
	20	1304K	+ H 304X	28	32	7	—	A 304X	14	39	24	8	0.045		
	20	2304K	+ H2304X	31	32	7	—	A2304X	14	39	24	5	0.050		
20	25	1205K	+ H 205X	26	38	8	—	A 205X	15	45	28	5	0.065		
	25	2205K	+ H 305X	29	38	8	—	A 305X	15	45	29	5	0.075		
	25	1305K	+ H 305X	29	38	8	—	A 305X	15	45	29	6	0.075		
	25	21305CDKE4	+ H 305X	29	38	8	—	A 305X	15	45	29	6	0.075		
25	2305K	+ H2305X	35	38	8	—	A2305X	15	45	29	5	0.090			
25	30	1206K	+ H 206X	27	45	8	—	A 206X	15	50	33	5	0.10		
	30	2206K	+ H 306X	31	45	8	—	A 306X	15	50	34	5	0.11		
	30	1306K	+ H 306X	31	45	8	—	A 306X	15	50	34	6	0.11		
	30	21306CDKE4	+ H 306X	31	45	8	—	A 306X	15	50	34	6	0.11		
30	2306K	+ H2306X	38	45	8	—	A2306X	15	50	35	5	0.125			
30	35	1207K	+ H 207X	29	52	9	—	A 207X	17	58	38	5	0.125		
	35	2207K	+ H 307X	35	52	9	—	A 307X	17	58	39	5	0.145		
	35	1307K	+ H 307X	35	52	9	—	A 307X	17	58	39	7	0.145		
	35	21307CDKE4	+ H 307X	35	52	9	—	A 307X	17	58	39	7	0.145		
35	2307K	+ H2307X	43	52	9	—	A2307X	17	58	40	5	0.16			
35	40	1208K	+ H 208X	31	58	10	—	A 208X	17	65	44	5	0.175		
	40	2208K	+ H 308X	36	58	10	—	A 308X	17	65	44	5	0.19		
	40	1308K	+ H 308X	36	58	10	—	A 308X	17	65	44	5	0.19		
	40	21308EAKE4	+ H 308X	36	58	10	—	A 308X	17	65	44	5	0.19		
40	2308K	+ H2308X	46	58	10	—	A2308X	17	65	45	5	0.225			
40	22308EAKE4	+ H2308X	46	58	10	—	A2308X	17	65	45	5	0.225			
40	45	1209K	+ H 209X	33	65	11	—	A 209X	17	72	49	5	0.225		
	45	2209K	+ H 309X	39	65	11	—	A 309X	17	72	49	8	0.26		
	45	1309K	+ H 309X	39	65	11	—	A 309X	17	72	49	5	0.26		
	45	21309EAKE4	+ H 309X	39	65	11	—	A 309X	17	72	49	5	0.26		
45	2309K	+ H2309X	50	65	11	—	A2309X	17	72	50	5	0.30			
45	22309EAKE4	+ H2309X	50	65	11	—	A2309X	17	72	50	5	0.30			

Remarks The suffix X represents adapter sleeves having narrow slits, for which washers with straight tabs should be used.

Shaft Diameter (mm) $d_1$	Nominal Bearing Bore Dia. (mm) $d$	Nominal Numbers				Dimensions (mm)				Adapter Sleeve Numbers	Abutment Dimensions (mm)				Mass (kg) approx
		Applicable Bearings				$B_1$	$d_2$	$B_2$	$B_5$		$A$ min	$K$ min	$d_e$ min	$b$ min	
45	50	1210K	+ H 210X	35	70	12	—	A 210X	19	76	53	5	0.275		
	50	2210K	+ H 310X	42	70	12	—	A 310X	19	76	54	10	0.30		
	50	1310K	+ H 310X	42	70	12	—	A 310X	19	76	54	5	0.30		
50	50	21310EAKE4	+ H 310X	42	70	12	—	A 310X	19	76	54	5	0.30		
	50	2310K	+ H2310X	55	70	12	—	A2310X	19	76	56	5	0.35		
	50	22310EAKE4	+ H2310X	55	70	12	—	A2310X	19	76	56	5	0.35		
50	55	1211K	+ H 211X	37	75	12	—	A 211X	19	85	60	6	0.305		
	55	2211K	+ H 311X	45	75	12	—	A 311X	19	85	60	11	0.35		
	55	22211EAKE4	+ H 311X	45	75	12	—	A 311X	19	85	60	11	0.35		
55	55	1311K	+ H 311X	45	75	12	—	A 311X	19	85	60	6	0.35		
	55	21311EAKE4	+ H 311X	45	75	12	—	A 311X	19	85	60	6	0.35		
	55	2311K	+ H2311X	59	75	12	—	A2311X	19	85	61	6	0.40		
	55	22311EAKE4	+ H2311X	59	75	12	—	A2311X	19	85	61	6	0.40		
55	60	1212K	+ H 212X	38	80	13	—	A 212X	20	90	64	5	0.365		
	60	2212K	+ H 312X	47	80	13	—	A 312X	20	90	65	9	0.40		
	60	22212EAKE4	+ H 312X	47	80	13	—	A 312X	20	90	65	9	0.40		
60	60	1312K	+ H 312X	47	80	13	—	A 312X	20	90	65	5	0.40		
	60	21312EAKE4	+ H 312X	47	80	13	—	A 312X	20	90	65	5	0.40		
	60	2312K	+ H2312X	62	80	13	—	A2312X	20	90	66	5	0.45		
	60	22312EAKE4	+ H2312X	62	80	13	—	A2312X	20	90	66	5	0.45		
60	65	1213K	+ H 213X	40	85	14	—	A 213X	21	96	70	5	0.40		
	65	2213K	+ H 313X	50	85	14	—	A 313X	21	96	70	8	0.45		
	65	22213EAKE4	+ H 313X	50	85	14	—	A 313X	21	96	70	8	0.45		
65	65	1313K	+ H 313X	50	85	14	—	A 313X	21	96	70	5	0.45		
	65	21313EAKE4	+ H 313X	50	85	14	—	A 313X	21	96	70	5	0.45		
	65	2313K	+ H2313X	65	85	14	—	A2313X	21	96	72	5	0.55		
	65	22313EAKE4	+ H2313X	65	85	14	—	A2313X	21	96	72	5	0.55		
70	70	22214EAKE4	+ H 314X	52	92	14	—	A 314X	21	96	70	8	0.65		
	70	21314EAKE4	+ H 314X	52	92	14	—	A 314X	21	96	70	5	0.65		
	70	22314EAKE4	+ H2314X	68	92	14	—	A2314X	21	96	72	5	0.80		

Remarks The suffix X represents adapter sleeves having narrow slits, for which washers with straight tabs should be used.

Shaft Diameter 65~80 mm

Shaft Diameter 85~115 mm

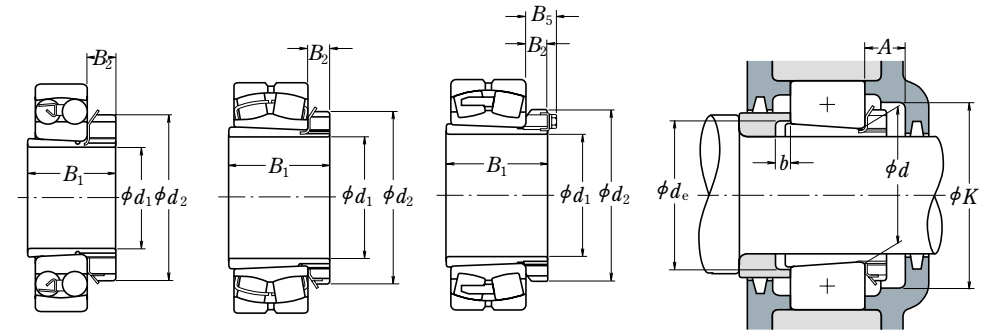
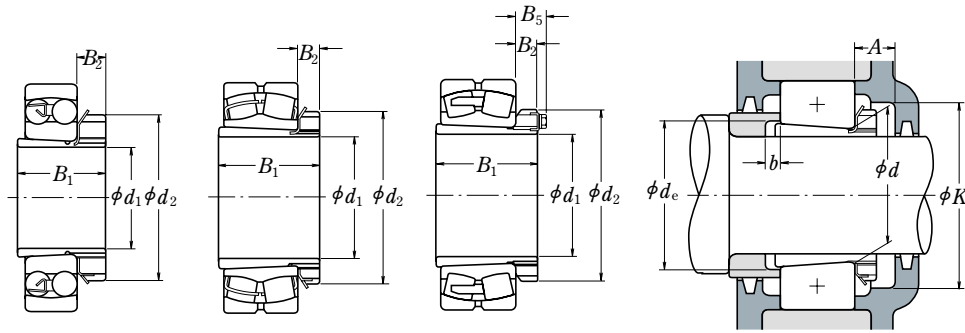

Shaft Diameter (mm) $d_1$	Nominal Bearing Bore Dia. (mm) $d$	Dimensions (mm)				Adapter Sleeve Numbers	Abutment Dimensions (mm)				Mass (kg) approx			
		$B_1$	$d_2$	$B_2$	$B_5$		$A$ min	$K$ min	$d_e$ min	$b$ min				
65	75	1215K	+ H 215X	43	98	15	—	A 215X	23	110	80	5	0.70	
	75	2215K	+ H 315X	55	98	15	—	A 315X	23	110	80	12	0.85	
	75	22215EAKE4	+ H 315X	55	98	15	—	A 315X	23	110	80	12	0.85	
	75	1315K	+ H 315X	55	98	15	—	A 315X	23	110	80	5	0.85	
	75	21315EAKE4	+ H 315X	55	98	15	—	A 315X	23	110	80	5	0.85	
	75	2315K	+ H2315X	73	98	15	—	A2315X	23	110	82	5	1.05	
	75	22315EAKE4	+ H2315X	73	98	15	—	A2315X	23	110	82	5	1.05	
	70	80	1216K	+ H 216X	46	105	17	—	A 216X	25	120	85	5	0.85
		80	2216K	+ H 316X	59	105	17	—	A 316X	25	120	86	12	1.05
		80	22216EAKE4	+ H 316X	59	105	17	—	A 316X	25	120	86	12	1.05
80		1316K	+ H 316X	59	105	17	—	A 316X	25	120	86	5	1.05	
80		21316EAKE4	+ H 316X	59	105	17	—	A 316X	25	120	86	5	1.05	
80		2316K	+ H2316X	78	105	17	—	A2316X	25	120	87	5	1.3	
80		22316EAKE4	+ H2316X	78	105	17	—	A2316X	25	120	87	5	1.3	
75		85	1217K	+ H 217X	50	110	18	—	A 217X	27	128	90	6	1.0
		85	2217K	+ H 317X	63	110	18	—	A 317X	27	128	91	12	1.2
		85	22217EAKE4	+ H 317X	63	110	18	—	A 317X	27	128	91	12	1.2
	85	1317K	+ H 317X	63	110	18	—	A 317X	27	128	91	6	1.2	
	85	21317EAKE4	+ H 317X	63	110	18	—	A 317X	27	128	91	6	1.2	
	85	2317K	+ H2317X	82	110	18	—	A2317X	27	128	94	6	1.45	
	85	22317EAKE4	+ H2317X	82	110	18	—	A2317X	27	128	94	6	1.45	
	80	90	1218K	+ H 218X	52	120	18	—	A 218X	28	139	95	6	1.15
		90	2218K	+ H 318X	65	120	18	—	A 318X	28	139	96	10	1.4
		90	22218EAKE4	+ H 318X	65	120	18	—	A 318X	28	139	96	10	1.4
90		1318K	+ H 318X	65	120	18	—	A 318X	28	139	96	6	1.4	
90		21318EAKE4	+ H 318X	65	120	18	—	A 318X	28	139	96	6	1.4	
90		2318K	+ H2318X	86	120	18	—	A2318X	28	139	99	6	1.7	
90		23218C KE4	+ H2318X	86	120	18	—	A2318X	28	139	99	6	1.7	
90		22318EAKE4	+ H2318X	86	120	18	—	A2318X	28	139	99	6	1.7	

Remarks The suffix X represents adapter sleeves having narrow slits, for which washers with straight tabs should be used.

Shaft Diameter (mm) $d_1$	Nominal Bearing Bore Dia. (mm) $d$	Dimensions (mm)				Adapter Sleeve Numbers	Abutment Dimensions (mm)				Mass (kg) approx			
		$B_1$	$d_2$	$B_2$	$B_5$		$A$ min	$K$ min	$d_e$ min	$b$ min				
85	95	1219K	+ H 219X	55	125	19	—	A 219X	29	145	101	7	1.35	
	95	2219K	+ H 319X	68	125	19	—	A 319X	29	145	102	9	1.55	
	95	22219EAKE4	+ H 319X	68	125	19	—	A 319X	29	145	102	9	1.55	
	95	1319K	+ H 319X	68	125	19	—	A 319X	29	145	102	7	1.55	
	95	21319C KE4	+ H 319X	68	125	19	—	A 319X	29	145	102	7	1.55	
	95	2319K	+ H2319X	90	125	19	—	A2319X	29	145	105	7	1.9	
	95	22319EAKE4	+ H2319X	90	125	19	—	A2319X	29	145	105	7	1.9	
	90	100	1220K	+ H 220X	58	130	20	—	A 220X	30	150	106	7	1.45
		100	2220K	+ H 320X	71	130	20	—	A 320X	30	150	107	8	1.7
		100	22220EAKE4	+ H 320X	71	130	20	—	A 320X	30	150	107	8	1.7
100		1320K	+ H 320X	71	130	20	—	A 320X	30	150	107	7	1.7	
100		21320C KE4	+ H 320X	71	130	20	—	A 320X	30	150	107	7	1.7	
100		2320K	+ H2320X	97	130	20	—	A2320X	30	150	110	7	2.15	
100		23220C KE4	+ H2320X	97	130	20	—	A2320X	30	150	110	7	2.15	
100		22320EAKE4	+ H2320X	97	130	20	—	A2320X	30	150	110	7	2.15	
100		110	23122C KE4	+ H3122X	81	145	21	—	A3122X	32	170	117	7	2.25
		110	1222K	+ H 222X	63	145	21	—	A 222X	32	170	116	7	1.95
	110	2222K	+ H 322X	77	145	21	—	A 322X	32	170	117	6	2.3	
	110	22222EAKE4	+ H 322X	77	145	21	—	A 322X	32	170	117	6	2.3	
	110	1322K	+ H 322X	77	145	21	—	A 322X	32	170	117	9	2.3	
	110	2322K	+ H2322X	105	145	21	—	A2322X	32	170	121	7	2.75	
	110	23222C KE4	+ H2322X	105	145	21	—	A2322X	32	170	121	17	2.75	
	110	22322EAKE4	+ H2322X	105	145	21	—	A2322X	32	170	121	7	2.75	
	110	120	23024C DKE4	+ H3024	72	145	22	—	A 3024	33	180	127	7	1.95
		120	23124C KE4	+ H3124	88	155	22	—	A 3124	33	180	128	7	2.65
120		22224EAKE4	+ H3124	88	155	22	—	A 3124	33	180	128	11	2.65	
120		23224C KE4	+ H2324	112	155	22	—	A 2324	33	180	131	17	3.2	
120		22324EAKE4	+ H2324	112	155	22	—	A 2324	33	180	131	7	3.2	
115		130	23026C DKE4	+ H3026	80	155	23	—	A 3026	34	190	137	8	2.85
		130	23126C KE4	+ H3126	92	165	23	—	A 3126	34	190	138	8	3.65
		130	22226EAKE4	+ H3126	92	165	23	—	A 3126	34	190	138	8	3.65
		130	23226C KE4	+ H2326	121	165	23	—	A 2326	34	190	142	21	4.6
		130	22326C KE4	+ H2326	121	165	23	—	A 2326	34	190	142	8	4.6

Remarks The suffix X represents adapter sleeves having narrow slits, for which washers with straight tabs should be used.



Shaft Diameter 125~170 mm

Shaft Diameter 180~260 mm

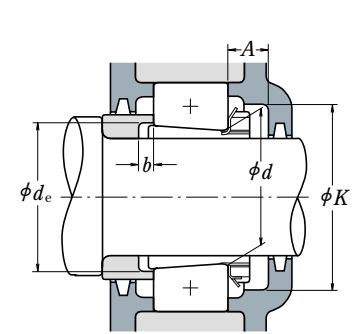
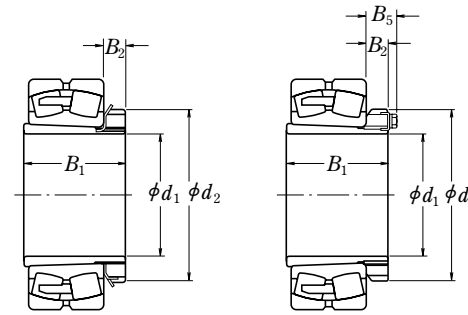
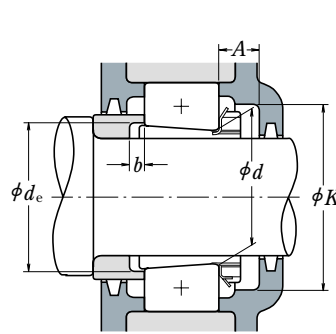
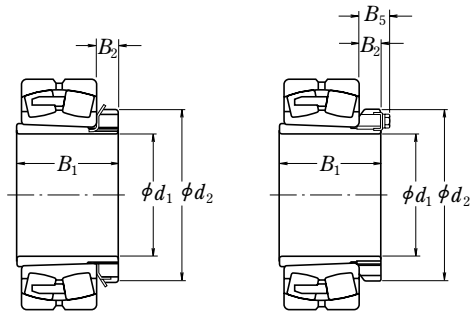

Shaft Diameter (mm) $d_1$	Nominal Bearing Bore Dia. (mm) $d$	Nominal Numbers Applicable Bearings	Dimensions (mm)				Adapter Sleeve Numbers	Abutment Dimensions (mm)				Mass (kg) approx
			$B_1$	$d_2$	$B_2$	$B_5$		$A$ min	$K$ min	$d_e$ min	$b$ min	
125	140	23028C DKE4 + <b>H3028</b>	82	165	24	—	A 3028	36	205	147	8	3.15
	140	23128C KE4 + <b>H3128</b>	97	180	24	—	A 3128	36	205	149	8	4.35
	140	22228C DKE4 + <b>H3128</b>	97	180	24	—	A 3128	36	205	149	8	4.35
	140	23228C KE4 + <b>H2328</b>	131	180	24	—	A 2328	36	205	152	22	5.55
	140	22328C KE4 + <b>H2328</b>	131	180	24	—	A 2328	36	205	152	8	5.55
	135	150	23030C DKE4 + <b>H3030</b>	87	180	26	—	A 3030	37	220	158	8
150		23130C KE4 + <b>H3130</b>	111	195	26	—	A 3130	37	220	160	8	5.5
150		22230C DKE4 + <b>H3130</b>	111	195	26	—	A 3130	37	220	160	15	5.5
150		23230C KE4 + <b>H2330</b>	139	195	26	—	A 2330	37	220	163	20	6.6
150		22330C AKE4 + <b>H2330</b>	139	195	26	—	A 2330	37	220	163	8	6.6
140		160	23932C AKE4 + <b>H3932</b>	78	190	28	—	A 3932	39	205	168	8
	160	23032C DKE4 + <b>H3032</b>	93	190	28	—	A 3032	39	230	168	8	5.2
	160	23132C KE4 + <b>H3132</b>	119	210	28	—	A 3132	39	230	170	8	7.65
	160	22232C DKE4 + <b>H3132</b>	119	210	28	—	A 3132	39	230	170	14	7.65
	160	23232C KE4 + <b>H2332</b>	147	210	28	—	A 2332	39	230	174	18	9.15
	160	22332C AKE4 + <b>H2332</b>	147	210	28	—	A 2332	39	230	174	8	9.15
150	170	23934B CAKE4 + <b>H3934</b>	79	200	29	—	A 3934	40	215	179	8	5.07
	170	23034C DKE4 + <b>H3034</b>	101	200	29	—	A 3034	40	250	179	8	6.0
	170	23134C KE4 + <b>H3134</b>	122	220	29	—	A 3134	40	250	180	8	8.4
	170	22234C DKE4 + <b>H3134</b>	122	220	29	—	A 3134	40	250	180	10	8.4
	170	23234C KE4 + <b>H2334</b>	154	220	29	—	A 2334	40	250	185	18	10
	170	22334C AKE4 + <b>H2334</b>	154	220	29	—	A 2334	40	250	185	8	10
160	180	23936C AKE4 + <b>H3936</b>	87	210	30	—	A 3936	41	230	189	8	5.87
	180	23036C DKE4 + <b>H3036</b>	109	210	30	—	A 3036	41	260	189	8	6.85
	180	23136C KE4 + <b>H3136</b>	131	230	30	—	A 3136	41	260	191	8	9.5
	180	22236C DKE4 + <b>H3136</b>	131	230	30	—	A 3136	41	260	191	18	9.5
	180	23236C KE4 + <b>H2336</b>	161	230	30	—	A 2336	41	260	195	22	11.5
	180	22336C AKE4 + <b>H2336</b>	161	230	30	—	A 2336	41	260	195	8	11.5
170	190	23938C AKE4 + <b>H3938</b>	89	220	31	—	A 3938	43	240	199	9	6.35
	190	23038C AKE4 + <b>H3038</b>	112	220	31	—	A 3038	43	270	199	9	7.45
	190	23138C KE4 + <b>H3138</b>	141	240	31	—	A 3138	43	270	202	9	11
	190	22238C AKE4 + <b>H3138</b>	141	240	31	—	A 3138	43	270	202	21	11
	190	23238C KE4 + <b>H2338</b>	169	240	31	—	A 2338	43	270	206	21	12.5
	190	22338C AKE4 + <b>H2338</b>	169	240	31	—	A 2338	43	270	206	9	12.5

Shaft Diameter (mm) $d_1$	Nominal Bearing Bore Dia. (mm) $d$	Nominal Numbers Applicable Bearings	Dimensions (mm)				Adapter Sleeve Numbers	Abutment Dimensions (mm)				Mass (kg) approx
			$B_1$	$d_2$	$B_2$	$B_5$		$A$ min	$K$ min	$d_e$ min	$b$ min	
180	200	23940C AKE4 + <b>H3940</b>	98	240	32	—	A 3940	46	260	210	10	8.0
	200	23040C AKE4 + <b>H3040</b>	120	240	32	—	A 3040	46	280	210	10	9.2
	200	23140C KE4 + <b>H3140</b>	150	250	32	—	A 3140	46	280	212	10	12
200	200	22240C AKE4 + <b>H3140</b>	150	250	32	—	A 3140	46	280	212	24	12
	200	23240C KE4 + <b>H2340</b>	176	250	32	—	A 2340	46	280	216	20	14
	200	22340C AKE4 + <b>H2340</b>	176	250	32	—	A 2340	46	280	216	10	14
200	220	23944C AKE4 + <b>H3944</b>	96	260	30	41	A 3944	55	280	231	10	8.32
	220	23044C AKE4 + <b>H3044</b>	128	260	30	41	A 3044	55	320	231	12	10.5
	220	23144C KE4 + <b>H3144</b>	158	280	32	44	A 3144	55	320	233	10	14.5
220	220	22244C AKE4 + <b>H3144</b>	158	280	32	44	A 3144	55	320	233	22	14.5
	220	23244C KE4 + <b>H2344</b>	183	280	32	44	A 2344	55	320	236	11	16.5
	220	22344C AKE4 + <b>H2344</b>	183	280	32	44	A 2344	55	320	236	10	16.5
220	240	23948C AKE4 + <b>H3948</b>	101	290	34	46	A 3948	60	300	251	11	11.2
	240	23048C AKE4 + <b>H3048</b>	133	290	34	46	A 3048	60	340	251	11	13
	240	23148C KE4 + <b>H3148</b>	169	300	34	46	A 3148	60	340	254	11	17.5
240	240	22248C AKE4 + <b>H3148</b>	169	300	34	46	A 3148	60	340	254	19	17.5
	240	23248C AKE4 + <b>H2348</b>	196	300	34	46	A 2348	60	340	257	6	19.5
	240	22348C AKE4 + <b>H2348</b>	196	300	34	46	A 2348	60	340	257	11	19.5
240	260	23952C AKE4 + <b>H3952</b>	116	310	34	46	A 3952	60	330	272	11	13.4
	260	23052C AKE4 + <b>H3052</b>	147	310	34	46	A 3052	60	370	272	13	15.5
	260	23152C AKE4 + <b>H3152</b>	187	330	36	49	A 3152	60	370	276	11	22
260	260	22252C AKE4 + <b>H3152</b>	187	330	36	49	A 3152	60	370	276	25	22
	260	23252C AKE4 + <b>H2352</b>	208	330	36	49	A 2352	60	370	278	2	24
	260	22352C AKE4 + <b>H2352</b>	208	330	36	49	A 2352	60	370	278	11	24
260	280	23956C AKE4 + <b>H3956</b>	121	330	38	50	A 3956	65	350	292	12	15.5
	280	23056C AKE4 + <b>H3056</b>	152	330	38	50	A 3056	65	390	292	12	17.5
	280	23156C AKE4 + <b>H3156</b>	192	350	38	51	A 3156	65	390	296	12	24.5
280	280	22256C AKE4 + <b>H3156</b>	192	350	38	51	A 3156	65	390	296	28	24.5
	280	23256C AKE4 + <b>H2356</b>	221	350	38	51	A 2356	65	390	299	11	28
	280	22356C AKE4 + <b>H2356</b>	221	350	38	51	A 2356	65	390	299	12	28

Shaft Diameter 280~410 mm

Shaft Diameter 430~470 mm

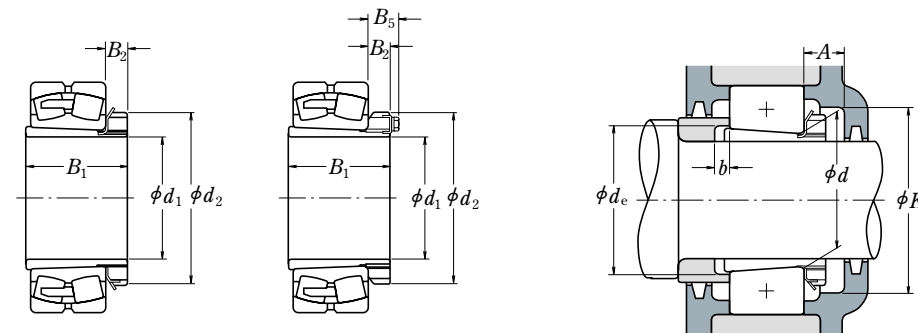
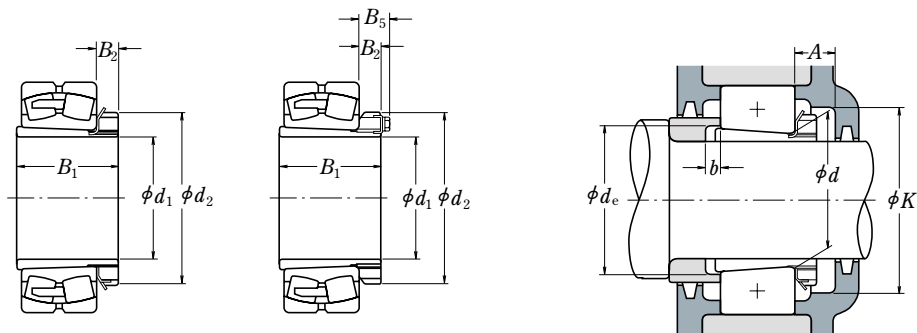

Shaft Diameter (mm) $d_1$	Nominal Bearing Bore Dia. (mm) $d$	Nominal Numbers Applicable Bearings	Dimensions (mm)				Adapter Sleeve Numbers	Abutment Dimensions (mm)				Mass (kg) approx
			$B_1$	$d_2$	$B_2$	$B_5$		$A$ min	$K$ min	$d_e$ min	$b$ min	
280	300	23960CAKE4 + <b>H3960</b>	140	360	42	54	A3960	69	380	313	12	20.7
	300	23060CAKE4 + <b>H3060</b>	168	360	42	54	A3060	69	430	313	12	23
	300	23160CAKE4 + <b>H3160</b>	208	380	40	53	A3160	69	430	317	12	30
	300	22260CAKE4 + <b>H3160</b>	208	380	40	53	A3160	69	430	317	32	30
	300	23260CAKE4 + <b>H3260</b>	240	380	40	53	A3260	69	430	321	12	34
	300	320	23964CAKE4 + <b>H3964</b>	140	380	42	55	A3964	72	400	334	13
320		23064CAKE4 + <b>H3064</b>	171	380	42	55	A3064	72	450	334	13	24.5
320		23164CAKE4 + <b>H3164</b>	226	400	42	56	A3164	72	450	339	13	35
320		22264CAKE4 + <b>H3164</b>	226	400	42	56	A3164	72	450	339	39	35
320		23264CAKE4 + <b>H3264</b>	258	400	42	56	A3264	72	450	343	13	39.5
320		340	23968CAKE4 + <b>H3968</b>	144	400	45	58	A3968	75	430	354	14
	340	23068CAKE4 + <b>H3068</b>	187	400	45	58	A3068	75	490	355	14	28.5
	340	23168CAKE4 + <b>H3168</b>	254	440	55	72	A3168	75	490	360	14	49.5
	340	23268CAKE4 + <b>H3268</b>	288	440	55	72	A3268	75	490	364	14	54.5
	340	360	23972CAKE4 + <b>H3972</b>	144	420	45	58	A3972	75	450	374	14
360		23072CAKE4 + <b>H3072</b>	188	420	45	58	A3072	75	510	375	14	30.5
360		23172CAKE4 + <b>H3172</b>	259	460	58	75	A3172	75	510	380	14	54
360		23272CAKE4 + <b>H3272</b>	299	460	58	75	A3272	75	510	385	14	60.5
360		380	23976CAKE4 + <b>H3976</b>	164	450	48	62	A3976	82	480	396	15
	380	23076CAKE4 + <b>H3076</b>	193	450	48	62	A3076	82	540	396	15	36
	380	23176CAKE4 + <b>H3176</b>	264	490	60	77	A3176	82	540	401	15	61.5
	380	23276CAKE4 + <b>H3276</b>	310	490	60	77	A3276	82	540	405	15	69.5
	380	400	23980CAKE4 + <b>H3980</b>	168	470	52	66	A3980	86	500	417	15
400		23080CAKE4 + <b>H3080</b>	210	470	52	66	A3080	86	580	417	15	41.5
400		23180CAKE4 + <b>H3180</b>	272	520	62	82	A3180	86	580	421	15	70.5
400		23280CAKE4 + <b>H3280</b>	328	520	62	82	A3280	86	580	427	15	81
400		420	23984CAKE4 + <b>H3984</b>	168	490	52	66	A3984	86	520	437	16
	420	23084CAKE4 + <b>H3084</b>	212	490	52	66	A3084	86	600	437	16	43.5
	420	23184CAKE4 + <b>H3184</b>	304	540	70	90	A3184	86	600	443	16	84
	420	23284CAKE4 + <b>H3284</b>	352	540	70	90	A3284	86	600	448	16	94
	410	440	23988CAKE4 + <b>H3988</b>	189	520	60	77	A3988	99	550	458	17
440		23088CAKE4 + <b>H3088</b>	228	520	60	77	A3088	99	620	458	17	65
440		23188CAKE4 + <b>H3188</b>	307	560	70	90	A3188	99	620	464	17	104
440		23288CAKE4 + <b>H3288</b>	361	560	70	90	A3288	99	620	469	17	118

Shaft Diameter (mm) $d_1$	Nominal Bearing Bore Dia. (mm) $d$	Nominal Numbers Applicable Bearings	Dimensions (mm)				Adapter Sleeve Numbers	Abutment Dimensions (mm)				Mass (kg) approx
			$B_1$	$d_2$	$B_2$	$B_5$		$A$ min	$K$ min	$d_e$ min	$b$ min	
430	460	23992CAKE4 + <b>H3992</b>	189	540	60	77	A3992	99	570	478	17	62
	460	23092CAKE4 + <b>H3092</b>	234	540	60	77	A3092	99	650	478	17	69.5
	460	23192CAKE4 + <b>H3192</b>	326	580	75	95	A3192	99	650	485	17	116
	460	23292CAKE4 + <b>H3292</b>	382	580	75	95	A3292	99	650	491	17	132
	450	480	23996CAKE4 + <b>H3996</b>	200	560	60	77	A3996	99	600	499	18
480		23096CAKE4 + <b>H3096</b>	237	560	60	77	A3096	99	690	499	18	73.5
480		23196CAKE4 + <b>H3196</b>	335	620	75	95	A3196	99	690	505	18	133
480		23296CAKE4 + <b>H3296</b>	397	620	75	95	A3296	99	690	512	18	152
470		500	239500CAKE4 + <b>H39500</b>	208	580	68	85	A39500	109	620	519	18
	500	230500CAKE4 + <b>H30500</b>	247	580	68	85	A30500	109	700	519	18	82
	500	231500CAKE4 + <b>H31500</b>	356	630	80	100	A31500	109	700	527	18	143
	500	232500CAKE4 + <b>H32500</b>	428	630	80	100	A32500	109	700	534	18	166

Shaft Diameter 35~85 mm

Shaft Diameter 90~135 mm

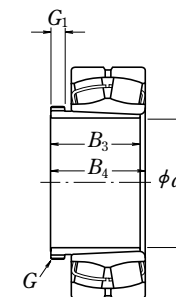
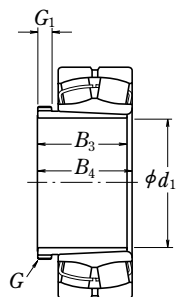

Shaft Diameter (mm) $d_1$	Nominal Bearing Bore Dia. (mm) $d$	Nominal Numbers Applicable Bearings	Screw Thread $G$	Dimensions (mm)			Mass (kg) approx
				$B_3$	$G_1$	$B_4$	
35	40	21308EAKE4 + AH 308	M 45 × 1.5	29	6	32	0.09
	40	22308EAKE4 + AH 2308	M 45 × 1.5	40	7	43	0.13
40	45	21309EAKE4 + AH 309	M 50 × 1.5	31	6	34	0.11
	45	22309EAKE4 + AH 2309	M 50 × 1.5	44	7	47	0.165
45	50	21310EAKE4 + AHX 310	M 55 × 2	35	7	38	0.16
	50	22310EAKE4 + AHX 2310	M 55 × 2	50	9	53	0.235
50	55	22211EAKE4 + AHX 311	M 60 × 2	37	7	40	0.19
	55	21311EAKE4 + AHX 311	M 60 × 2	37	7	40	0.19
	55	22311EAKE4 + AHX 2311	M 60 × 2	54	10	57	0.285
55	60	22212EAKE4 + AHX 312	M 65 × 2	40	8	43	0.215
	60	21312EAKE4 + AHX 312	M 65 × 2	40	8	43	0.215
	60	22312EAKE4 + AHX 2312	M 65 × 2	58	11	61	0.34
60	65	22213EAKE4 + AH 313	M 75 × 2	42	8	45	0.255
	65	21313EAKE4 + AH 313	M 75 × 2	42	8	45	0.255
	65	22313EAKE4 + AH 2313	M 75 × 2	61	12	64	0.395
65	70	22214EAKE4 + AH 314	M 80 × 2	43	8	47	0.28
	70	21314EAKE4 + AH 314	M 80 × 2	43	8	47	0.28
	70	22314EAKE4 + AHX 2314	M 80 × 2	64	12	68	0.53
70	75	22215EAKE4 + AH 315	M 85 × 2	45	8	49	0.315
	75	21315EAKE4 + AH 315	M 85 × 2	45	8	49	0.315
	75	22315EAKE4 + AHX 2315	M 85 × 2	68	12	72	0.605
75	80	22216EAKE4 + AH 316	M 90 × 2	48	8	52	0.365
	80	21316EAKE4 + AH 316	M 90 × 2	48	8	52	0.365
	80	22316EAKE4 + AHX 2316	M 90 × 2	71	12	75	0.665
80	85	22217EAKE4 + AHX 317	M 95 × 2	52	9	56	0.48
	85	21317EAKE4 + AHX 317	M 95 × 2	52	9	56	0.48
	85	22317EAKE4 + AHX 2317	M 95 × 2	74	13	78	0.745
85	90	22218EAKE4 + AHX 318	M 100 × 2	53	9	57	0.52
	90	21318EAKE4 + AHX 318	M 100 × 2	53	9	57	0.52
	90	23218CKE4 + AHX 3218	M 100 × 2	63	10	67	0.58
	90	22318EAKE4 + AHX 2318	M 100 × 2	79	14	83	0.845

Shaft Diameter (mm) $d_1$	Nominal Bearing Bore Dia. (mm) $d$	Nominal Numbers Applicable Bearings	Screw Thread $G$	Dimensions (mm)			Mass (kg) approx
				$B_3$	$G_1$	$B_4$	
90	95	22219EAKE4 + AHX 319	M 105 × 2	57	10	61	0.595
	95	21319CKE4 + AHX 319	M 105 × 2	57	10	61	0.595
	95	22319EAKE4 + AHX 2319	M 105 × 2	85	16	89	0.89
95	100	21320CKE4 + AHX 3120	M 110 × 2	64	11	68	0.70
	100	22220EAKE4 + AHX 320	M 110 × 2	59	10	63	0.66
	100	21320CKE4 + AHX 320	M 110 × 2	59	10	63	0.66
	100	23220CKE4 + AHX 3220	M 110 × 2	73	11	77	0.77
	100	22320EAKE4 + AHX 2320	M 110 × 2	90	16	94	1.0
105	110	23122CKE4 + AHX 3122	M 120 × 2	68	11	72	0.76
	110	22222EAKE4 + AHX 3122	M 120 × 2	68	11	72	0.76
	110	24122CK30E4 + AH 24122	M 115 × 2	82	13	91	0.73
110	110	23222CKE4 + AHX 3222	M 125 × 2	82	11	86	1.04
	110	22322EAKE4 + AHX 2322	M 125 × 2	98	16	102	1.35
115	120	23024CDKE4 + AHX 3024	M 130 × 2	60	13	64	0.75
	120	24024CK30E4 + AH 24024	M 125 × 2	73	13	82	0.70
	120	23124CKE4 + AHX 3124	M 130 × 2	75	12	79	0.95
120	120	22224EAKE4 + AHX 3124	M 130 × 2	75	12	79	0.95
	120	24124CK30E4 + AH 24124	M 130 × 2	93	13	102	1.02
	120	23224CKE4 + AHX 3224	M 135 × 2	90	13	94	1.3
	120	22324EAKE4 + AHX 2324	M 135 × 2	105	17	109	1.6
	120	23026CDKE4 + AHX 3026	M 140 × 2	67	14	71	0.95
125	130	24026CK30E4 + AH 24026	M 135 × 2	83	14	93	0.89
	130	23126CKE4 + AHX 3126	M 140 × 2	78	12	82	1.08
	130	22226EAKE4 + AHX 3126	M 140 × 2	78	12	82	1.08
130	130	24126CK30E4 + AH 24126	M 140 × 2	94	14	104	1.14
	130	23226CKE4 + AHX 3226	M 145 × 2	98	15	102	1.58
	130	22326CKE4 + AHX 2326	M 145 × 2	115	19	119	1.97
	130	23028CDKE4 + AHX 3028	M 150 × 2	68	14	73	1.01
	130	24028CK30E4 + AH 24028	M 145 × 2	83	14	93	0.96
135	140	23128CKE4 + AHX 3128	M 150 × 2	83	14	88	1.28
	140	22228CDKE4 + AHX 3128	M 150 × 2	83	14	88	1.28
	140	24128CK30E4 + AH 24128	M 150 × 2	99	14	109	1.3
	140	23228CKE4 + AHX 3228	M 155 × 3	104	15	109	1.84
	140	22328CKE4 + AHX 2328	M 155 × 3	125	20	130	2.33
	140	23028CDKE4 + AHX 3028	M 150 × 2	68	14	73	1.01
	140	24028CK30E4 + AH 24028	M 145 × 2	83	14	93	0.96

Shaft Diameter 145~180 mm

Shaft Diameter 190~260 mm

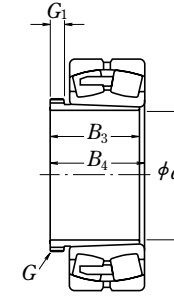
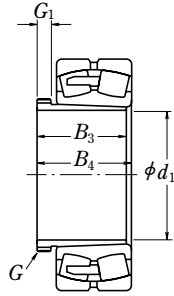

Shaft Diameter (mm) $d_1$	Nominal Bearing Bore Dia. (mm) $d$	Nominal Numbers Applicable Bearings	Screw Thread $G$	Dimensions (mm)			Mass (kg) approx
				$B_3$	$G_1$	$B_4$	
145	150	23030CDKE4 + AHX 3030	M 160 × 3	72	15	77	1.15
	150	24030CK30E4 + AH 24030	M 155 × 3	90	15	101	1.11
	150	23130CKE4 + AHX 3130	M 165 × 3	96	15	101	1.79
	150	22230CDKE4 + AHX 3130	M 165 × 3	96	15	101	1.79
	150	24130CK30E4 + AH 24130	M 160 × 3	115	15	126	1.63
	150	23230CKE4 + AHX 3230	M 165 × 3	114	17	119	2.22
	150	22330CAKE4 + AHX 2330	M 165 × 3	135	24	140	2.82
150	160	23032CDKE4 + AH 3032	M 170 × 3	77	16	82	2.05
	160	24032CK30E4 + AH 24032	M 170 × 3	95	15	106	2.28
	160	23132CKE4 + AH 3132	M 180 × 3	103	16	108	3.2
	160	22232CDKE4 + AH 3132	M 180 × 3	103	16	108	3.2
	160	24132CK30E4 + AH 24132	M 170 × 3	124	15	135	3.03
	160	23232CKE4 + AH 3232	M 180 × 3	124	20	130	4.1
	160	22332CAKE4 + AH 2332	M 180 × 3	140	24	146	4.7
160	170	23034CDKE4 + AH 3034	M 180 × 3	85	17	90	2.45
	170	24034CK30E4 + AH 24034	M 180 × 3	106	16	117	2.74
	170	23134CKE4 + AH 3134	M 190 × 3	104	16	109	3.4
	170	22234CDKE4 + AH 3134	M 190 × 3	104	16	109	3.4
	170	24134CK30E4 + AH 24134	M 180 × 3	125	16	136	3.26
	170	23234CKE4 + AH 3234	M 190 × 3	134	24	140	4.8
	170	22334CAKE4 + AH 2334	M 190 × 3	146	24	152	5.25
170	180	23036CDKE4 + AH 3036	M 190 × 3	92	17	98	2.8
	180	24036CK30E4 + AH 24036	M 190 × 3	116	16	127	3.19
	180	23136CKE4 + AH 3136	M 200 × 3	116	19	122	4.2
	180	24136CK30E4 + AH 24136	M 190 × 3	134	16	145	3.74
	180	22236CDKE4 + AH 2236	M 200 × 3	105	17	110	3.75
	180	23236CKE4 + AH 3236	M 200 × 3	140	24	146	5.3
	180	22336CAKE4 + AH 2336	M 200 × 3	154	26	160	5.85
180	190	23038CAKE4 + AH 3038	Tr 205 × 4	96	18	102	3.35
	190	24038CK30E4 + AH 24038	M 200 × 3	118	18	131	3.47
	190	23138CKE4 + AH 3138	Tr 210 × 4	125	20	131	4.9
	190	24138CK30E4 + AH 24138	M 200 × 3	146	18	159	4.38
	190	22238CAKE4 + AH 2238	Tr 210 × 4	112	18	117	4.25
	190	23238CKE4 + AH 3238	Tr 210 × 4	145	25	152	5.9
	190	22338CAKE4 + AH 2338	Tr 210 × 4	160	26	167	6.65

Shaft Diameter (mm) $d_1$	Nominal Bearing Bore Dia. (mm) $d$	Nominal Numbers Applicable Bearings	Screw Thread $G$	Dimensions (mm)			Mass (kg) approx
				$B_3$	$G_1$	$B_4$	
190	200	23040CAKE4 + AH 3040	Tr 215 × 4	102	19	108	3.8
	200	24040CK30E4 + AH 24040	Tr 210 × 4	127	18	140	3.92
	200	23140CKE4 + AH 3140	Tr 220 × 4	134	21	140	5.5
	200	24140CK30E4 + AH 24140	Tr 210 × 4	158	18	171	5.0
	200	22240CAKE4 + AH 2240	Tr 220 × 4	118	19	123	4.7
	200	23240CKE4 + AH 3240	Tr 220 × 4	153	25	160	6.7
	200	22340CAKE4 + AH 2340	Tr 220 × 4	170	30	177	7.55
200	220	23044CAKE4 + AH 3044	Tr 235 × 4	111	20	117	7.4
	220	24044CK30E4 + AH 24044	Tr 230 × 4	138	20	152	8.23
	220	23144CKE4 + AH 3144	Tr 240 × 4	145	23	151	10.5
	220	24144CK30E4 + AH 24144	Tr 230 × 4	170	20	184	10.3
	220	22244CAKE4 + AH 2244	Tr 240 × 4	130	20	136	9.1
	220	23244CKE4 + AH 3244	Tr 240 × 4	181	30	189	13.5
	220	22344CAKE4 + AH 2344	Tr 240 × 4	181	30	189	13.5
220	240	23048CAKE4 + AH 3048	Tr 260 × 4	116	21	123	8.75
	240	24048CK30E4 + AH 24048	Tr 250 × 4	138	20	153	9.0
	240	23148CKE4 + AH 3148	Tr 260 × 4	154	25	161	12
	240	24148CK30E4 + AH 24148	Tr 260 × 4	180	20	195	12.6
	240	22248CAKE4 + AH 2248	Tr 260 × 4	144	21	150	11
	240	23248CAKE4 + AH 3248	Tr 260 × 4	189	30	197	15.5
	240	22348CAKE4 + AH 2348	Tr 260 × 4	189	30	197	15.5
240	260	23052CAKE4 + AH 3052	Tr 280 × 4	128	23	135	10.5
	260	24052CAK30E4 + AH 24052	Tr 270 × 4	162	22	178	11.7
	260	23152CAKE4 + AH 3152	Tr 290 × 4	172	26	179	16
	260	24152CAK30E4 + AH 24152	Tr 280 × 4	202	22	218	15.5
	260	22252CAKE4 + AH 2252	Tr 290 × 4	155	23	161	14
	260	23252CAKE4 + AH 3252	Tr 290 × 4	205	30	213	19.5
	260	22352CAKE4 + AH 2352	Tr 290 × 4	205	30	213	19.5
260	280	23056CAKE4 + AH 3056	Tr 300 × 4	131	24	139	12
	280	24056CAK30E4 + AH 24056	Tr 290 × 4	162	22	179	12.6
	280	23156CAKE4 + AH 3156	Tr 310 × 5	175	28	183	17.5
	280	24156CAK30E4 + AH 24156	Tr 300 × 4	202	22	219	16.8
	280	22256CAKE4 + AH 2256	Tr 310 × 5	155	24	163	15
	280	23256CAKE4 + AH 3256	Tr 310 × 5	212	30	220	21.5
	280	22356CAKE4 + AH 2356	Tr 310 × 5	212	30	220	21.5

Shaft Diameter 280~380 mm

Shaft Diameter 400~480 mm

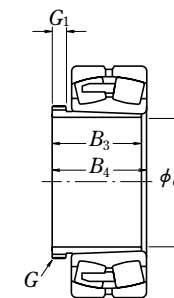
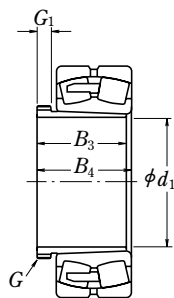

Shaft Diameter (mm) $d_1$	Nominal Bearing Bore Dia. (mm) $d$	Nominal Numbers Applicable Bearings	Screw Thread $G$	Dimensions (mm)			Mass (kg) approx
				$B_3$	$G_1$	$B_4$	
280	300	23060CAKE4 + AH 3060	Tr 320 × 5	145	26	153	14.5
	300	24060CAK30E4 + AH 24060	Tr 310 × 5	184	24	202	15.5
	300	23160CAKE4 + AH 3160	Tr 330 × 5	192	30	200	21
300	300	24160CAK30E4 + AH 24160	Tr 320 × 5	224	24	242	20.3
	300	22260CAKE4 + AH 2260	Tr 330 × 5	170	26	178	18
	300	23260CAKE4 + AH 3260	Tr 330 × 5	228	34	236	20
300	320	23064CAKE4 + AH 3064	Tr 345 × 5	149	27	157	16
	320	24064CAK30E4 + AH 24064	Tr 330 × 5	184	24	202	16.4
	320	23164CAKE4 + AH 3164	Tr 350 × 5	209	31	217	24.5
320	320	24164CAK30E4 + AH 24164	Tr 340 × 5	242	24	260	23.5
	320	23264CAKE4 + AH 3264	Tr 350 × 5	246	36	254	25
320	340	23068CAKE4 + AH 3068	Tr 365 × 5	162	28	171	19.5
	340	24068CAK30E4 + AH 24068	Tr 360 × 5	206	26	225	21.2
	340	23168CAKE4 + AH 3168	Tr 370 × 5	225	33	234	29
340	340	24168CAK30E4 + AH 24168	Tr 360 × 5	269	26	288	28.3
	340	23268CAKE4 + AH 3268	Tr 370 × 5	264	38	273	35.5
340	360	23072CAKE4 + AH 3072	Tr 385 × 5	167	30	176	21
	360	24072CAK30E4 + AH 24072	Tr 380 × 5	206	26	226	22.5
	360	23172CAKE4 + AH 3172	Tr 400 × 5	229	35	238	33
360	360	24172CAK30E4 + AH 24172	Tr 380 × 5	269	26	289	30
	360	23272CAKE4 + AH 3272	Tr 400 × 5	274	40	283	41.5
360	380	23076CAKE4 + AH 3076	Tr 410 × 5	170	31	180	23.5
	380	24076CAK30E4 + AH 24076	Tr 400 × 5	208	28	228	24.1
	380	23176CAKE4 + AH 3176	Tr 420 × 5	232	36	242	35.5
380	380	24176CAK30E4 + AH 24176	Tr 400 × 5	271	28	291	32.1
	380	23276CAKE4 + AH 3276	Tr 420 × 5	284	42	294	45.5
380	400	23080CAKE4 + AH 3080	Tr 430 × 5	183	33	193	27.5
	400	24080CAK30E4 + AH 24080	Tr 420 × 5	228	28	248	28
	400	23180CAKE4 + AH 3180	Tr 440 × 5	240	38	250	39.5
400	400	24180CAK30E4 + AH 24180	Tr 420 × 5	278	28	298	34.8
	400	23280CAKE4 + AH 3280	Tr 440 × 5	302	44	312	51.5

Shaft Diameter (mm) $d_1$	Nominal Bearing Bore Dia. (mm) $d$	Nominal Numbers Applicable Bearings	Screw Thread $G$	Dimensions (mm)			Mass (kg) approx
				$B_3$	$G_1$	$B_4$	
400	420	23084CAKE4 + AH 3084	Tr 450 × 5	186	34	196	29
	420	24084CAK30E4 + AH 24084	Tr 440 × 5	230	30	252	29.8
	420	23184CAKE4 + AH 3184	Tr 460 × 5	266	40	276	46.5
420	420	24184CAK30E4 + AH 24184	Tr 440 × 5	310	30	332	41.4
	420	23284CAKE4 + AH 3284	Tr 460 × 5	321	46	331	59
420	440	23088CAKE4 + AHX 3088	Tr 470 × 5	194	35	205	42
	440	24088CAK30E4 + AH 24088	Tr 460 × 5	242	30	264	33
	440	23188CAKE4 + AHX 3188	Tr 480 × 5	270	42	281	50
440	440	24188CAK30E4 + AH 24188	Tr 460 × 5	310	30	332	43.5
	440	23288CAKE4 + AHX 3288	Tr 480 × 5	330	48	341	64
440	460	23092CAKE4 + AHX 3092	Tr 490 × 5	202	37	213	46
	460	24092CAK30E4 + AH 24092	Tr 480 × 5	250	32	273	35.9
	460	23192CAKE4 + AHX 3192	Tr 510 × 6	285	43	296	58
460	460	24192CAK30E4 + AH 24192	Tr 480 × 5	332	32	355	49.7
	460	23292CAKE4 + AHX 3292	Tr 510 × 6	349	50	360	74.5
460	480	23096CAKE4 + AHX 3096	Tr 520 × 6	205	38	217	51
	480	24096CAK30E4 + AH 24096	Tr 500 × 5	250	32	273	37.5
	480	23196CAKE4 + AHX 3196	Tr 530 × 6	295	45	307	63
480	480	24196CAK30E4 + AH 24196	Tr 500 × 5	340	32	363	53
	480	23296CAKE4 + AHX 3296	Tr 530 × 6	364	52	376	82
480	500	230/500CAKE4 + AHX 30/500	Tr 540 × 6	209	40	221	54.5
	500	240/500CAK30E4 + AH 240/500	Tr 530 × 6	253	35	276	41.9
	500	231/500CAKE4 + AHX 31/500	Tr 550 × 6	313	47	325	71
500	500	241/500CAK30E4 + AH 241/500	Tr 530 × 6	360	35	383	61.2
	500	232/500CAKE4 + AHX 32/500	Tr 550 × 6	393	54	405	94.5

(For Adapters and Shafts)

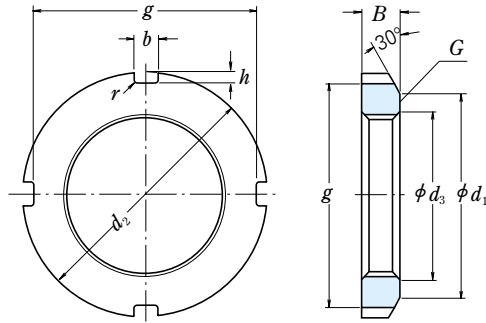

Nut with Washer

Units : mm

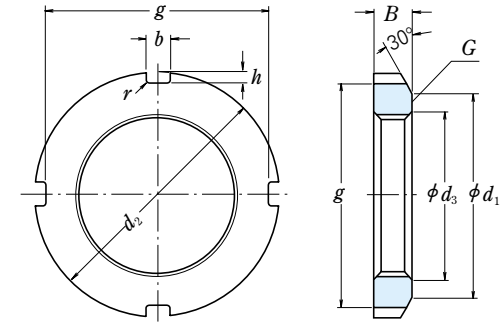

Nut with Washer

Units : mm

Nominal Numbers	Nut Series AN										Reference		
	Screw Threads G	d <sub>2</sub>	d <sub>1</sub>	g	b	h	d <sub>3</sub>	B	r <sub>max</sub>	Mass (kg) approx	Adapter (1) Sleeve Bore Dia. Numbers	Washer Numbers	Shaft Dia.
AN 02	M 15x1	25	21	21	4	2	15.5	5	0.4	0.010	—	AW 02 X	15
AN 03	M 17x1	28	24	24	4	2	17.5	5	0.4	0.013	—	AW 03 X	17
AN 04	M 20x1	32	26	28	4	2	20.5	6	0.4	0.019	04	AW 04 X	20
AN 05	M 25x1.5	38	32	34	5	2	25.8	7	0.4	0.025	05	AW 05 X	25
AN 06	M 30x1.5	45	38	41	5	2	30.8	7	0.4	0.043	06	AW 06 X	30
AN 07	M 35x1.5	52	44	48	5	2	35.8	8	0.4	0.053	07	AW 07 X	35
AN 08	M 40x1.5	58	50	53	6	2.5	40.8	9	0.5	0.085	08	AW 08 X	40
AN 09	M 45x1.5	65	56	60	6	2.5	45.8	10	0.5	0.119	09	AW 09 X	45
AN 10	M 50x1.5	70	61	65	6	2.5	50.8	11	0.5	0.148	10	AW 10 X	50
AN 11	M 55x2	75	67	69	7	3	56	11	0.5	0.158	11	AW 11 X	55
AN 12	M 60x2	80	73	74	7	3	61	11	0.5	0.174	12	AW 12 X	60
AN 13	M 65x2	85	79	79	7	3	66	12	0.5	0.203	13	AW 13 X	65
AN 14	M 70x2	92	85	85	8	3.5	71	12	0.5	0.242	14	AW 14 X	70
AN 15	M 75x2	98	90	91	8	3.5	76	13	0.5	0.287	15	AW 15 X	75
AN 16	M 80x2	105	95	98	8	3.5	81	15	0.6	0.395	16	AW 16 X	80
AN 17	M 85x2	110	102	103	8	3.5	86	16	0.6	0.45	17	AW 17 X	85
AN 18	M 90x2	120	108	112	10	4	91	16	0.6	0.555	18	AW 18 X	90
AN 19	M 95x2	125	113	117	10	4	96	17	0.6	0.66	19	AW 19 X	95
AN 20	M 100x2	130	120	122	10	4	101	18	0.6	0.70	20	AW 20 X	100
AN 21	M 105x2	140	126	130	12	5	106	18	0.7	0.845	21	AW 21 X	105
AN 22	M 110x2	145	133	135	12	5	111	19	0.7	0.965	22	AW 22 X	110
AN 23	M 115x2	150	137	140	12	5	116	19	0.7	1.01	—	AW 23	115
AN 24	M 120x2	155	138	145	12	5	121	20	0.7	1.08	24	AW 24	120
AN 25	M 125x2	160	148	150	12	5	126	21	0.7	1.19	—	AW 25	125

Note (1) Applicable to adapter sleeve Series A31, A2, A3, and A23.

Remarks The basic design and dimensions of screw threads are in accordance with JIS B 0207.

Nominal Numbers	Nut Series AN										Reference		
	Screw Threads G	d <sub>2</sub>	d <sub>1</sub>	g	b	h	d <sub>3</sub>	B	r <sub>max</sub>	Mass (kg) approx	Adapter (1) Sleeve Bore Dia. Numbers	Washer Numbers	Shaft Dia.
AN 26	M 130x2	165	149	155	12	5	131	21	0.7	1.25	26	AW 26	130
AN 27	M 135x2	175	160	163	14	6	136	22	0.7	1.55	—	AW 27	135
AN 28	M 140x2	180	160	168	14	6	141	22	0.7	1.56	28	AW 28	140
AN 29	M 145x2	190	172	178	14	6	146	24	0.7	2.0	—	AW 29	145
AN 30	M 150x2	195	171	183	14	6	151	24	0.7	2.03	30	AW 30	150
AN 31	M 155x3	200	182	186	16	7	156.5	25	0.7	2.21	—	—	—
AN 32	M 160x3	210	182	196	16	7	161.5	25	0.7	2.59	32	AW 32	160
AN 33	M 165x3	210	193	196	16	7	166.5	26	0.7	2.43	—	—	—
AN 34	M 170x3	220	193	206	16	7	171.5	26	0.7	2.8	34	AW 34	170
AN 36	M 180x3	230	203	214	18	8	181.5	27	0.7	3.05	36	AW 36	180
AN 38	M 190x3	240	214	224	18	8	191.5	28	0.7	3.4	38	AW 38	190
AN 40	M 200x3	250	226	234	18	8	201.5	29	0.7	3.7	40	AW 40	200

Nut Series ANL													
Nominal Numbers	Nut Series ANL										Reference		
	Screw Threads G	d <sub>2</sub>	d <sub>1</sub>	g	b	h	d <sub>3</sub>	B	r <sub>max</sub>	Mass (kg) approx	Adapter (1) Sleeve Bore Dia. Numbers	Washer Numbers	Shaft Dia.
ANL 24	M 120x2	145	133	135	12	5	121	20	0.7	0.78	24	AWL 24	120
ANL 26	M 130x2	155	143	145	12	5	131	21	0.7	0.88	26	AWL 26	130
ANL 28	M 140x2	165	151	153	14	6	141	22	0.7	0.99	28	AWL 28	140
ANL 30	M 150x2	180	164	168	14	6	151	24	0.7	1.38	30	AWL 30	150
ANL 32	M 160x3	190	174	176	16	7	161.5	25	0.7	1.56	32	AWL 32	160
ANL 34	M 170x3	200	184	186	16	7	171.5	26	0.7	1.72	34	AWL 34	170
ANL 36	M 180x3	210	192	194	18	8	181.5	27	0.7	1.95	36	AWL 36	180
ANL 38	M 190x3	220	202	204	18	8	191.5	28	0.7	2.08	38	AWL 38	190
ANL 40	M 200x3	240	218	224	18	8	201.5	29	0.7	2.98	40	AWL 40	200

Note (1) Series AN is applicable to adapter sleeve Series A31 and A23.

Series ANL is applicable to adapter sleeve Series A30.

Remarks The basic design and dimensions of screw threads are in accordance with JIS B 0207.



(For Adapters and Shafts)

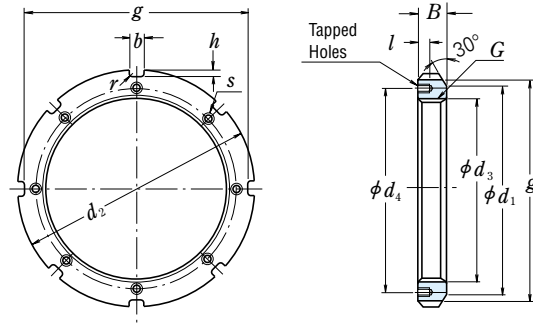

Nut with Stopper

Units : mm

Nominal Numbers	Nut Series AN											Reference			
	Screw Threads G	Basic Dimensions							Tapped Holes Screw Threads (S)	Mass (kg) approx	Adapter (°) Sleeve Bore Dia. Numbers	Stopper Numbers	Shaft Dia.		
$d_2$	$d_1$	$g$	$b$	$h$	$d_3$	$B$	$r_{max}$	$l$						$d_4$	
AN 44	Tr 220x4	280	250	260	20	10	222	32	0.8	15 M 8x1.25	238	5.2	44	AL 44	220
AN 48	Tr 240x4	300	270	280	20	10	242	34	0.8	15 M 8x1.25	258	5.95	48	AL 44	240
AN 52	Tr 260x4	330	300	306	24	12	262	36	0.8	18 M 10x1.5	281	8.05	52	AL 52	260
AN 56	Tr 280x4	350	320	326	24	12	282	38	0.8	18 M 10x1.5	301	9.05	56	AL 52	280
AN 60	Tr 300x4	380	340	356	24	12	302	40	0.8	18 M 10x1.5	326	11.8	60	AL 60	300
AN 64	Tr 320x5	400	360	376	24	12	322.5	42	0.8	18 M 10x1.5	345	13.1	64	AL 64	320
AN 68	Tr 340x5	440	400	410	28	15	342.5	55	1	21 M 12x1.75	372	23.1	68	AL 68	340
AN 72	Tr 360x5	460	420	430	28	15	362.5	58	1	21 M 12x1.75	392	25.1	72	AL 76	360
AN 76	Tr 380x5	490	450	454	32	18	382.5	60	1	21 M 12x1.75	414	31	76	AL 76	380
AN 80	Tr 400x5	520	470	484	32	18	402.5	62	1	27 M 16x2	439	37	80	AL 80	400
AN 84	Tr 420x5	540	490	504	32	18	422.5	70	1	27 M 16x2	459	43.5	84	AL 80	420
AN 88	Tr 440x5	560	510	520	36	20	442.5	70	1	27 M 16x2	477	45	88	AL 88	440
AN 92	Tr 460x5	580	540	540	36	20	462.5	75	1	27 M 16x2	497	50.5	92	AL 88	460
AN 96	Tr 480x5	620	560	580	36	20	482.5	75	1	27 M 16x2	527	62	96	AL 96	480
AN 100	Tr 500x5	630	580	584	40	23	502.5	80	1	27 M 16x2	539	63.5	/500	AL 100	500

Nut Series ANL

ANL 44	Tr 220x4	260	242	242	20	9	222	30	0.8	12 M 6x1	229	3.1	44	ALL 44	220
ANL 48	Tr 240x4	290	270	270	20	10	242	34	0.8	15 M 8x1.25	253	5.15	48	ALL 48	240
ANL 52	Tr 260x4	310	290	290	20	10	262	34	0.8	15 M 8x1.25	273	5.65	52	ALL 48	260
ANL 56	Tr 280x4	330	310	310	24	10	282	38	0.8	15 M 8x1.25	293	6.8	56	ALL 56	280
ANL 60	Tr 300x4	360	336	336	24	12	302	42	0.8	15 M 8x1.25	316	9.6	60	ALL 60	300
ANL 64	Tr 320x5	380	356	356	24	12	322.5	42	0.8	15 M 8x1.25	335	9.95	64	ALL 64	320
ANL 68	Tr 340x5	400	376	376	24	12	342.5	45	1	15 M 8x1.25	355	11.7	68	ALL 64	340
ANL 72	Tr 360x5	420	394	394	28	13	362.5	45	1	15 M 8x1.25	374	12	72	ALL 72	360
ANL 76	Tr 380x5	450	422	422	28	14	382.5	48	1	18 M 10x1.5	398	14.9	76	ALL 76	380
ANL 80	Tr 400x5	470	442	442	28	14	402.5	52	1	18 M 10x1.5	418	16.9	80	ALL 76	400
ANL 84	Tr 420x5	490	462	462	32	14	422.5	52	1	18 M 10x1.5	438	17.4	84	ALL 84	420
ANL 88	Tr 440x5	520	490	490	32	15	442.5	60	1	21 M 12x1.75	462	26.2	88	ALL 88	440
ANL 92	Tr 460x5	540	510	510	32	15	462.5	60	1	21 M 12x1.75	482	28	92	ALL 88	460
ANL 96	Tr 480x5	560	530	530	36	15	482.5	60	1	21 M 12x1.75	502	29.5	96	ALL 96	480
ANL 100	Tr 500x5	580	550	550	36	15	502.5	68	1	21 M 12x1.75	522	33.5	/500	ALL 96	500

Note (1) Series AN is applicable to adapter sleeve Series A31, A32 and A23. Series ANL is applicable to adapter sleeve Series A30.

Remarks 1. The basic design and dimensions of screw threads are in accordance with JIS B 0216.  
2. The basic design and dimensions of threads in tapped holes are in accordance with JIS B 0205.

(For Withdrawal Sleeves)

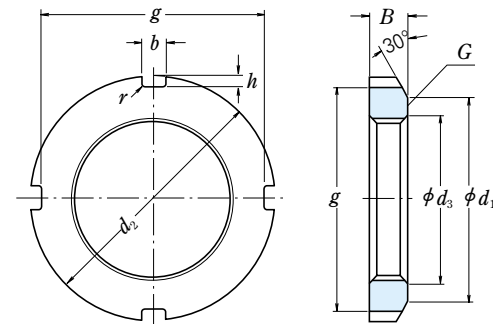

Units : mm

Nominal Numbers	Nut Series HN											Reference			
	Screw Threads G	Basic Dimensions							Mass (kg) approx	Withdrawal Sleeve Numbers					
$d_2$	$d_1$	$g$	$b$	$h$	$d_3$	$B$	$r_{max}$	AH 31		AH 22	AH 32	AH 23			
HN 42	Tr 210x4	270	238	250	20	10	212	30	0.8	4.75	AH 3138	AH 2238	AH 3238	AH 2338	
HN 44	Tr 220x4	280	250	260	20	10	222	32	0.8	5.35	AH 3140	AH 2240	AH 3240	AH 2340	
HN 48	Tr 240x4	300	270	280	20	10	242	34	0.8	6.2	AH 3144	AH 2244	—	AH 2344	
HN 52	Tr 260x4	330	300	306	24	12	262	36	0.8	8.55	AH 3148	AH 2248	—	AH 2348	
HN 58	Tr 290x4	370	330	346	24	12	292	40	0.8	11.8	AH 3152	AH 2252	—	AH 2352	
HN 62	Tr 310x5	390	350	366	24	12	312.5	42	0.8	13.4	AH 3156	AH 2256	—	AH 2356	
HN 66	Tr 330x5	420	380	390	28	15	332.5	52	1	20.4	AH 3160	AH 2260	AH 3260	—	
HN 70	Tr 350x5	450	410	420	28	15	352.5	55	1	25.2	AH 3164	AH 2264	AH 3264	—	
HN 74	Tr 370x5	470	430	440	28	15	372.5	58	1	28.2	AH 3168	—	AH 3268	—	
HN 80	Tr 400x5	520	470	484	32	18	402.5	62	1	40	AH 3172	—	AH 3272	—	
HN 84	Tr 420x5	540	490	504	32	18	422.5	70	1	46.9	AH 3176	—	AH 3276	—	
HN 88	Tr 440x5	560	510	520	36	20	442.5	70	1	48.5	AH 3180	—	AH 3280	—	
HN 92	Tr 460x5	580	540	540	36	20	462.5	75	1	55	AH 3184	—	AH 3284	—	
HN 96	Tr 480x5	620	560	580	36	20	482.5	75	1	67	AHX 3188	—	AHX 3288	—	
HN 102	Tr 510x6	650	590	604	40	23	513	80	1	75	AHX 3192	—	AHX 3292	—	
HN 106	Tr 530x6	670	610	624	40	23	533	80	1	78	AHX 3196	—	AHX 3296	—	
HN 110	Tr 550x6	700	640	654	40	23	553	80	1	92.5	AHX 31/500	—	AHX 32/500	—	

Nut Series HNL

Nominal Numbers	Nut Series HNL											AH 30	AH 2
	Screw Threads G	Basic Dimensions							Mass (kg) approx	Reference			
$d_2$	$d_1$	$g$	$b$	$h$	$d_3$	$B$	$r_{max}$	AH 30		AH 2			
HNL 41	Tr 205x4	250	232	234	18	8	207	30	0.8	3.45	AH 3038	AH 238	
HNL 43	Tr 215x4	260	242	242	20	9	217	30	0.8	3.7	AH 3040	AH 240	
HNL 47	Tr 235x4	280	262	262	20	9	237	34	0.8	4.6	AH 3044	AH 244	
HNL 52	Tr 260x4	310	290	290	20	10	262	34	0.8	5.8	AH 3048	AH 248	
HNL 56	Tr 280x4	330	310	310	24	10	282	38	0.8	6.7	AH 3052	AH 252	
HNL 60	Tr 300x4	360	336	336	24	12	302	42	0.8	9.6	AH 3056	AH 256	
HNL 64	Tr 320x5	380	356	356	24	12	322.5	42	1	10.3	AH 3060	—	
HNL 69	Tr 345x5	410	384	384	28	13	347.5	45	1	11.5	AH 3064	—	
HNL 73	Tr 365x5	430	404	404	28	13	367.5	48	1	14.2	AH 3068	—	
HNL 77	Tr 385x5	450	422	422	28	14	387.5	48	1	15	AH 3072	—	
HNL 82	Tr 410x5	480	452	452	32	14	412.5	52	1	19	AH 3076	—	
HNL 86	Tr 430x5	500	472	472	32	14	432.5	52	1	19.8	AH 3080	—	
HNL 90	Tr 450x5	520	490	490	32	15	452.5	60	1	23.8	AH 3084	—	
HNL 94	Tr 470x5	540	510	510	32	15	472.5	60	1	25	AHX 3088	—	
HNL 98	Tr 490x5	580	550	550	36	15	492.5	60	1	34	AHX 3092	—	
HNL 104	Tr 520x6	600	570	570	36	15	523	68	1	37	AHX 3096	—	
HNL 108	Tr 540x6	630	590	590	40	20	543	68	1	43.5	AHX 30/500	—	

Remarks 1. The basic design and dimensions of screw threads are in accordance with JIS B 0216.  
2. The number of notches in the nut may be bigger than that shown in the above figure.

# NUTS FOR ROLLING BEARINGS

(Combination of Withdrawal Sleeves and Nuts)

# STOPPERS FOR NUTS

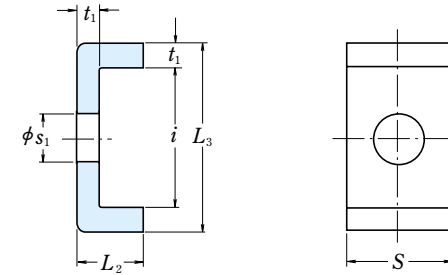

Units : mm

Nominal Numbers	Reference							
	Withdrawal Sleeve Numbers							
	AH 30	AH 31	AH 2	AH 22	AH 32	AH 3	AH 23	
AN 09	—	—	AH 208	—	—	AH 308	AH 2308	
AN 10	—	—	AH 209	—	—	AH 309	AH 2309	
AN 11	—	—	AH 210	—	—	AHX 310	AHX 2310	
AN 12	—	—	AH 211	—	—	AHX 311	AHX 2311	
AN 13	—	—	AH 212	—	—	AHX 312	AHX 2312	
AN 14	—	—	—	—	—	—	—	
AN 15	—	—	AH 213	—	—	AH 313	AH 2313	
AN 16	—	—	AH 214	—	—	AH 314	AHX 2314	
AN 17	—	—	AH 215	—	—	AH 315	AHX 2315	
AN 18	—	—	AH 216	—	—	AH 316	AHX 2316	
AN 19	—	—	AH 217	—	—	AHX 317	AHX 2317	
AN 20	—	—	AH 218	—	AHX 3218	AHX 318	AHX 2318	
AN 21	—	—	AH 219	—	—	AHX 319	AHX 2319	
AN 22	—	—	AH 220	—	AHX 3220	AHX 320	AHX 2320	
AN 23	—	—	AH 221	—	—	AHX 321	—	
AN 24	—	AHX 3122	AH 222	—	—	AHX 322	—	
AN 25	—	—	—	—	AHX 3222	—	AHX 2322	
AN 26	AHX 3024	AHX 3124	AH 224	—	—	AHX 324	—	
AN 27	—	—	—	—	AHX 3224	—	AHX 2324	
AN 28	AHX 3026	AHX 3126	AH 226	—	—	AHX 326	—	
AN 29	—	—	—	—	AHX 3226	—	AHX 2326	
AN 30	AHX 3028	AHX 3128	AH 228	—	—	AHX 328	—	
AN 31	—	—	—	—	AHX 3228	—	AHX 2328	
AN 32	AHX 3030	—	AH 230	—	—	—	—	
AN 33	—	AHX 3130	—	—	AHX 3230	AHX 330	AHX 2330	
AN 34	AH 3032	—	AH 232	—	—	—	—	
AN 36	AH 3034	AH 3132	AH 234	—	AH 3232	AH 332	AH 2332	
AN 38	AH 3036	AH 3134	AH 236	—	AH 3234	AH 334	AH 2334	
AN 40	—	AH 3136	—	AH 2236	AH 3236	—	AH 2336	

Nominal Numbers	Stopper Series AL							Reference	
	Basic Dimensions							Mass (kg) per 100 pcs approx	Nut Numbers
	t <sub>1</sub>	S	L <sub>2</sub>	s <sub>1</sub>	i	L <sub>3</sub>			
AL 44	4	20	12	9	22.5	30.5	2.6	AN 44, AN 48 AN 52, AN 56 AN 60	
AL 52	4	24	12	12	25.5	33.5	3.4		
AL 60	4	24	12	12	30.5	38.5	3.8		
AL 64	5	24	15	12	31	41	5.35	AN 64 AN 68, AN 72 AN 76	
AL 68	5	28	15	14	38	48	6.65		
AL 76	5	32	15	14	40	50	7.95		
AL 80	5	32	15	18	45	55	8.2	AN 80, AN 84 AN 88, AN 92 AN 96 AN 100	
AL 88	5	36	15	18	43	53	9.0		
AL 96	5	36	15	18	53	63	10.4		
AL 100	5	40	15	18	45	55	10.5		

Nominal Numbers	Stopper Series ALL							Reference	
	Basic Dimensions							Mass (kg) per 100 pcs approx	Nut Numbers
	t <sub>1</sub>	S	L <sub>2</sub>	s <sub>1</sub>	i	L <sub>3</sub>			
ALL 44	4	20	12	7	13.5	21.5	2.12	ANL 44 ANL 48, ANL 52 ANL 56	
ALL 48	4	20	12	9	17.5	25.5	2.29		
ALL 56	4	24	12	9	17.5	25.5	2.92		
ALL 60	4	24	12	9	20.5	28.5	3.15	ANL 60 ANL 64, ANL 68 ANL 72	
ALL 64	5	24	15	9	21	31	4.55		
ALL 72	5	28	15	9	20	30	5.05		
ALL 76	5	28	15	12	24	34	5.3	ANL 76, ANL 80 ANL 84 ANL 88, ANL 92 ANL 96, ANL 100	
ALL 84	5	32	15	12	24	34	6.1		
ALL 88	5	32	15	14	28	38	6.45		
ALL 96	5	36	15	14	28	38	7.3		

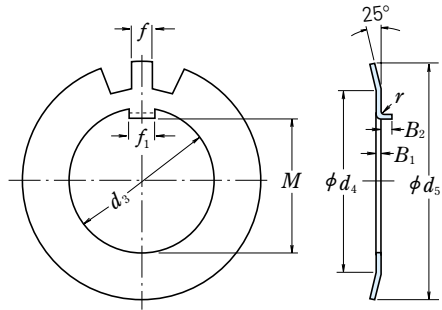

Bent-Tab

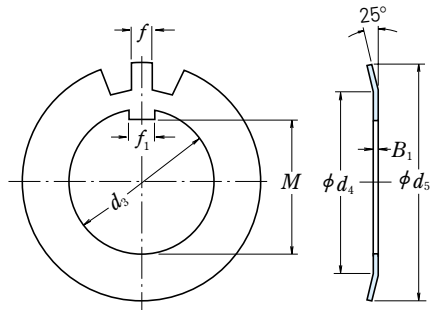

Straight-Tab

Units : mm

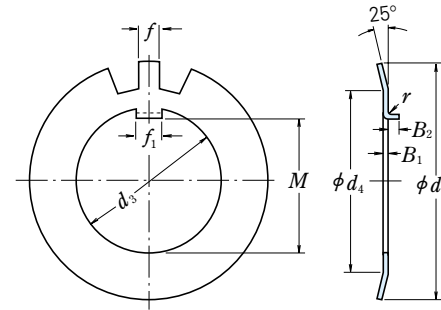

Bent-Tab

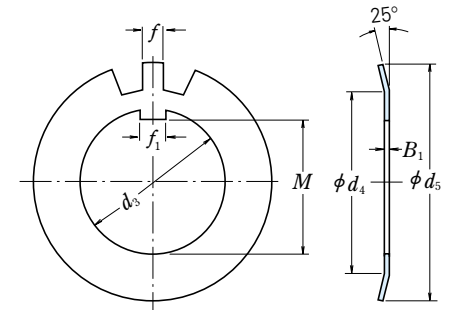

Straight-Tab

Units : mm

Nominal Numbers		Washer Series AW										Reference				
Bent-Tab	Straight-Tab	Basic Dimensions										No. of Teeth	Mass (kg) per 100 pcs approx	Adapter <sup>(1)</sup> Sleeve Bore Dia. Numbers	Nut Numbers	Shaft Dia.
		$d_3$	$M$	$f_1$	$B_1$	$f$	$d_4$	$d_5$	Bent-Tab $r$	Straight-Tab $B_2$						
<b>AW 02</b>	<b>AW 02 X</b>	15	13.5	4	1	4	21	28	1	2.5	13	0.253	—	<b>AN 02</b>	15	
<b>AW 03</b>	<b>AW 03 X</b>	17	15.5	4	1	4	24	32	1	2.5	13	0.315	—	<b>AN 03</b>	17	
<b>AW 04</b>	<b>AW 04 X</b>	20	18.5	4	1	4	26	36	1	2.5	13	0.35	04	<b>AN 04</b>	20	
<b>AW 05</b>	<b>AW 05 X</b>	25	23	5	1.2	5	32	42	1	2.5	13	0.64	05	<b>AN 05</b>	25	
<b>AW 06</b>	<b>AW 06 X</b>	30	27.5	5	1.2	5	38	49	1	2.5	13	0.78	06	<b>AN 06</b>	30	
<b>AW 07</b>	<b>AW 07 X</b>	35	32.5	6	1.2	5	44	57	1	2.5	15	1.04	07	<b>AN 07</b>	35	
<b>AW 08</b>	<b>AW 08 X</b>	40	37.5	6	1.2	6	50	62	1	2.5	15	1.23	08	<b>AN 08</b>	40	
<b>AW 09</b>	<b>AW 09 X</b>	45	42.5	6	1.2	6	56	69	1	2.5	17	1.52	09	<b>AN 09</b>	45	
<b>AW 10</b>	<b>AW 10 X</b>	50	47.5	6	1.2	6	61	74	1	2.5	17	1.6	10	<b>AN 10</b>	50	
<b>AW 11</b>	<b>AW 11 X</b>	55	52.5	8	1.2	7	67	81	1	4	17	1.96	11	<b>AN 11</b>	55	
<b>AW 12</b>	<b>AW 12 X</b>	60	57.5	8	1.5	7	73	86	1.2	4	17	2.53	12	<b>AN 12</b>	60	
<b>AW 13</b>	<b>AW 13 X</b>	65	62.5	8	1.5	7	79	92	1.2	4	19	2.9	13	<b>AN 13</b>	65	
<b>AW 14</b>	<b>AW 14 X</b>	70	66.5	8	1.5	8	85	98	1.2	4	19	3.35	14	<b>AN 14</b>	70	
<b>AW 15</b>	<b>AW 15 X</b>	75	71.5	8	1.5	8	90	104	1.2	4	19	3.55	15	<b>AN 15</b>	75	
<b>AW 16</b>	<b>AW 16 X</b>	80	76.5	10	1.8	8	95	112	1.2	4	19	4.65	16	<b>AN 16</b>	80	
<b>AW 17</b>	<b>AW 17 X</b>	85	81.5	10	1.8	8	102	119	1.2	4	19	5.25	17	<b>AN 17</b>	85	
<b>AW 18</b>	<b>AW 18 X</b>	90	86.5	10	1.8	10	108	126	1.2	4	19	6.25	18	<b>AN 18</b>	90	
<b>AW 19</b>	<b>AW 19 X</b>	95	91.5	10	1.8	10	113	133	1.2	4	19	6.7	19	<b>AN 19</b>	95	
<b>AW 20</b>	<b>AW 20 X</b>	100	96.5	12	1.8	10	120	142	1.2	6	19	7.65	20	<b>AN 20</b>	100	
<b>AW 21</b>	<b>AW 21 X</b>	105	100.5	12	1.8	12	126	145	1.2	6	19	8.25	21	<b>AN 21</b>	105	
<b>AW 22</b>	<b>AW 22 X</b>	110	105.5	12	1.8	12	133	154	1.2	6	19	9.4	22	<b>AN 22</b>	110	
<b>AW 23</b>	<b>AW 23 X</b>	115	110.5	12	2	12	137	159	1.5	6	19	10.8	—	<b>AN 23</b>	115	
<b>AW 24</b>	<b>AW 24 X</b>	120	115	14	2	12	138	164	1.5	6	19	10.5	24	<b>AN 24</b>	120	
<b>AW 25</b>	<b>AW 25 X</b>	125	120	14	2	12	148	170	1.5	6	19	11.8	—	<b>AN 25</b>	125	

Note <sup>(1)</sup> Applicable to adapter sleeve Series A31, A2, A3, and A23.

Remarks Washers with straight tabs shall be used with adapter sleeves having narrow slits, and for those having wide slits, either type of washer may be used.

Nominal Numbers		Washer Series AW										Reference				
Bent-Tab	Straight-Tab	Basic Dimensions										No. of Teeth	Mass (kg) per 100 pcs approx	Adapter <sup>(1)</sup> Sleeve Bore Dia. Numbers	Nut Numbers	Shaft Dia.
		$d_3$	$M$	$f_1$	$B_1$	$f$	$d_4$	$d_5$	Bent-Tab $r$	Straight-Tab $B_2$						
<b>AW 26</b>	<b>AW 26 X</b>	130	125	14	2	12	149	175	1.5	6	19	11.3	26	<b>AN 26</b>	130	
<b>AW 27</b>	<b>AW 27 X</b>	135	130	14	2	14	160	185	1.5	6	19	14.4	—	<b>AN 27</b>	135	
<b>AW 28</b>	<b>AW 28 X</b>	140	135	16	2	14	160	192	1.5	8	19	14.2	28	<b>AN 28</b>	140	
<b>AW 29</b>	<b>AW 29 X</b>	145	140	16	2	14	172	202	1.5	8	19	16.8	—	<b>AN 29</b>	145	
<b>AW 30</b>	<b>AW 30 X</b>	150	145	16	2	14	171	205	1.5	8	19	15.9	30	<b>AN 30</b>	150	
<b>AW 31</b>	<b>AW 31 X</b>	155	147.5	16	2.5	16	182	212	1.5	8	19	20.9	—	<b>AN 31</b>	155	
<b>AW 32</b>	<b>AW 32 X</b>	160	154	18	2.5	16	182	217	1.5	8	19	22.2	32	<b>AN 32</b>	160	
<b>AW 33</b>	<b>AW 33 X</b>	165	157.5	18	2.5	16	193	222	1.5	8	19	24.1	—	<b>AN 33</b>	165	
<b>AW 34</b>	<b>AW 34 X</b>	170	164	18	2.5	16	193	232	1.5	8	19	24.7	34	<b>AN 34</b>	170	
<b>AW 36</b>	<b>AW 36 X</b>	180	174	20	2.5	18	203	242	1.5	8	19	26.8	36	<b>AN 36</b>	180	
<b>AW 38</b>	<b>AW 38 X</b>	190	184	20	2.5	18	214	252	1.5	8	19	27.8	38	<b>AN 38</b>	190	
<b>AW 40</b>	<b>AW 40 X</b>	200	194	20	2.5	18	226	262	1.5	8	19	29.3	40	<b>AN 40</b>	200	

Washer Series AWL

<b>AWL 24</b>	<b>AWL 24 X</b>	120	115	14	2	12	133	155	1.5	6	19	7.7	24	<b>ANL 24</b>	120
<b>AWL 26</b>	<b>AWL 26 X</b>	130	125	14	2	12	143	165	1.5	6	19	8.7	26	<b>ANL 26</b>	130
<b>AWL 28</b>	<b>AWL 28 X</b>	140	135	16	2	14	151	175	1.5	8	19	10.9	28	<b>ANL 28</b>	140
<b>AWL 30</b>	<b>AWL 30 X</b>	150	145	16	2	14	164	190	1.5	8	19	11.3	30	<b>ANL 30</b>	150
<b>AWL 32</b>	<b>AWL 32 X</b>	160	154	18	2.5	16	174	200	1.5	8	19	16.2	32	<b>ANL 32</b>	160
<b>AWL 34</b>	<b>AWL 34 X</b>	170	164	18	2.5	16	184	210	1.5	8	19	19	34	<b>ANL 34</b>	170
<b>AWL 36</b>	<b>AWL 36 X</b>	180	174	20	2.5	18	192	220	1.5	8	19	18	36	<b>ANL 36</b>	180
<b>AWL 38</b>	<b>AWL 38 X</b>	190	184	20	2.5	18	202	230	1.5	8	19	20.5	38	<b>ANL 38</b>	190
<b>AWL 40</b>	<b>AWL 40 X</b>	200	194	20	2.5	18	218	250	1.5	8	19	21.4	40	<b>ANL 40</b>	200

Note <sup>(1)</sup> Series AW is applicable to adapter sleeve Series A31 and A23. Series AWL is applicable to adapter sleeve Series A30.

Remarks Washers with straight tabs shall be used with adapter sleeves having narrow slits, and for those having wide slits, either type of washer may be used.

# INTRODUCTION OF NSK PRODUCTS - APPENDICES

## INTRODUCTION OF NSK PRODUCTS

	Page
Photos of NSK Products.....	C 2~C 7

## APPENDICES

Appendix Table 1 Conversion from SI (International Units) System .....	C 8~C 9
Appendix Table 2 N-kgf Force Conversion Table .....	C10
Appendix Table 3 kg-lb Mass Conversion Table .....	C11
Appendix Table 4 °C-°F Temperature Conversion Table .....	C12
Appendix Table 5 Viscosity Conversion Table .....	C13
Appendix Table 6 inch-mm Dimension Conversion Table .....	C14~C15
Appendix Table 7 Hardness Conversion Table .....	C16
Appendix Table 8 Physical and Mechanical Properties of Materials .....	C17
Appendix Table 9 Tolerances for Shaft Diameters .....	C18~C19
Appendix Table 10 Tolerances for Housing Bore Diameters .....	C20~C21
Appendix Table 11 Values of Standard Tolerance Grades IT .....	C22~C23
Appendix Table 12 Speed Factor $f_h$ .....	C24
Appendix Table 13 Fatigue Life Factor $f_h$ and Fatigue Life $L \cdot L_h$ .....	C25
Appendix Table 14 Index of Inch Design Tapered Roller Bearings .....	C26~C33

**AUTOMOTIVE PRODUCTS**



Column Type Electric Power Steering  
(CAT.No. E4102)



Pinion Type Electric Power Steering  
(CAT.No. E4102)



Offset Ball Screw Type Electric Power Steering  
(CAT.No. E4102)



Long Life Water Pump Bearings  
(CAT.No. E396, E4102)



Hub Unit Bearings  
(CAT.No. E4201)



One-Way Clutch  
(CAT.No. E4102)

**PRECISION MACHINE COMPONENTS**

**BALL SCREWS**



Precision Ball Screws  
(CAT.No. E3161)



High-speed Low-noise  
Ball Screws BSS Series  
(CAT.No. E3229)



Ball Screw for standard  
stock compact FA Series  
(CAT.No. E3230)



Ball Screws for Standard  
stock VFA Series  
(CAT.No. E3161)



Ball Screws for High-Load  
Drive HTF Series  
(CAT.No. E3218)

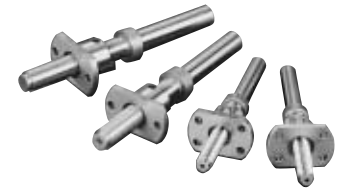

Precision Miniature Ball  
Screws  
(CAT.No. E3161)



Precision Hollow Shaft  
Ball Screws  
(CAT.No. E3161)



NSK New  $\Sigma$  Series  
ROBOTTE Ball Screws  
with Spline  
(CAT.No. E3161)



Rolled Ball Screws  
(CAT.No. E3161)

**MONOCARRIERS**



Monocarriers  
(CAT.No. E3161)



PRECISION MACHINE COMPONENTS

LINEAR BEARINGS



NSK Linear Guides and Ball Screws Equipped with "NSK K1™" Lubrication Unit (CAT.No. E3161)

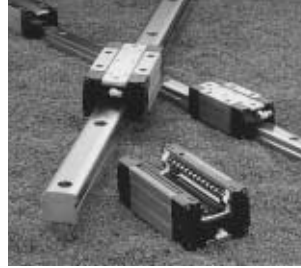

Translide™, New Type of Rolling Element Linear Motion Bearing (CAT.No. E3324)



NSK Linear Guides Self-aligning LH Series · LS Series (CAT.No. E3161)



NSK Linear Guides Miniature PU and PE Series (CAT.No. E3327)

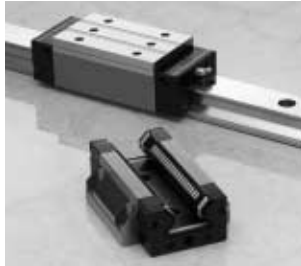

NSK Linear Guides Roller Guide RA Series (CAT.No. E3328)



NSK S1™ Series Precision Linear Guides (CAT.No. E3320)

ASSORTED SPINDLES



High Speed Integrated Motor Spindles



Precision Grinding Spindles (CAT.No. E2202)



Live Centers (CAT.No. E2202)



Oil/Air Lubricating Unit, Fine Lube (CAT.No. E1254/A1387)



Standard Type Precision Boring Heads (CAT.No. E2202)



Spindles for Electrical and Electric Equipment

PRECISION MACHINE COMPONENTS

MECHATRONIC ACTUATORS

Megatorque Motors PS Series (CAT.No. E3510)

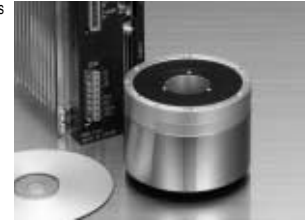

Robot Modules



Megatorque Motors YSB Series

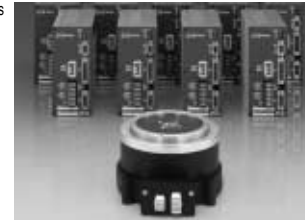

XY Tables



Megatorque Motors RS Series



Megathrust Motors Y Series

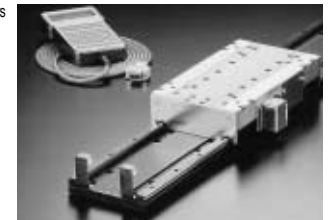

Megathrust Motors PM Series



Air Bearing Slides

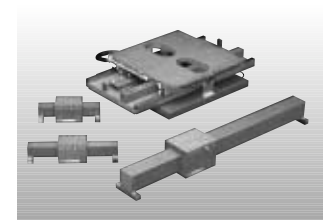

(CAT.No. E3156)



AIR SPINDLES



Air-spindle

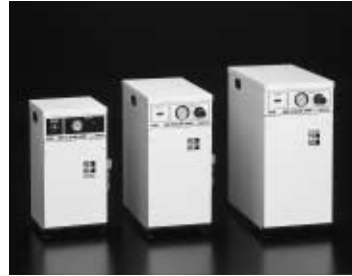

Air Cleaner Unit



DD Air-spindle

Large Size Proximity Stepper RZ Series



RELATED PRODUCT WITH BEARING



Bearing Induction Heater  
(CAT.No. E398)

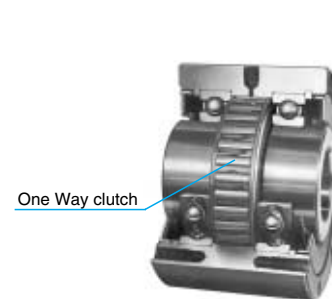

One Way clutch

One Way clutch  
(Package Type)



Extra Small Bearing Monitor  
NB-4  
(Bearing Abnormality Detector)  
(CAT.No. E410)

Appendix Table 1 Conversion Table from SI (International Units) System

Comparison of SI, CGS, and Engineering Units

Unit System	Units				Units					
	Length	Mass	Time	Temp.	Acceleration	Force	Stress	Pressure	Energy	Power
SI	m	kg	s	K, °C	m/s <sup>2</sup>	N	Pa	Pa	J	W
CGS System	cm	g	s	°C	Gal	dyn	dyn/cm <sup>2</sup>	dyn/cm <sup>2</sup>	erg	erg/s
Engineering Unit System	m	kgf · s <sup>2</sup> /m	s	°C	m/s <sup>2</sup>	kgf	kgf/m <sup>2</sup>	kgf/m <sup>2</sup>	kgf · m	kgf · m/s

Prefixes Used In SI System

Multiples	Prefix	Symbols	Multiples	Prefix	Symbols
10 <sup>18</sup>	Exa	E	10 <sup>-1</sup>	Deci	d
10 <sup>15</sup>	Peta	P	10 <sup>-2</sup>	Centi	c
10 <sup>12</sup>	Tera	T	10 <sup>-3</sup>	Milli	m
10 <sup>9</sup>	Giga	G	10 <sup>-6</sup>	Micro	μ
10 <sup>6</sup>	Mega	M	10 <sup>-9</sup>	Nano	n
10 <sup>3</sup>	Kilo	k	10 <sup>-12</sup>	Pico	p
10 <sup>2</sup>	Hecto	h	10 <sup>-15</sup>	Femto	f
10 <sup>1</sup>	Deca	da	10 <sup>-18</sup>	Ato	a

Conversion Factors from SI Units

Parameter	SI Units		Units other than SI		Conversion Factors from SI Units
	Names of Units	Symbols	Name of Units	Symbols	
Angle	Radian	rad	Degree	°	180/π
			Minute	'	10 800/π
			Second	"	648 000/π
Length	Meter	m	Micron	μ	10 <sup>6</sup>
			Angstrom	Å	10 <sup>10</sup>
Area	Square meter	m <sup>2</sup>	Are	a	10 <sup>-2</sup>
			Hectare	ha	10 <sup>-4</sup>
Volume	Cubic meter	m <sup>3</sup>	Liter	l, L	10 <sup>3</sup>
			Deciliter	dl, dL	10 <sup>4</sup>
Time	Second	s	Minute	min	1/60
			Hour	h	1/3 600
			Day	d	1/86 400
Frequency	Hertz	Hz	Cycle	s <sup>-1</sup>	1
Speed of Rotation	Revolution per second	s <sup>-1</sup>	Revolution per minute	rpm	60
Speed	Meter per second	m/s	Kilometer per hour	km/h	3 600/1 000
			Knot	kn	3 600/1 852
Acceleration	Meter per second per second	m/s <sup>2</sup>	Gal	Gal	10 <sup>2</sup>
			g	G	1/9.806 65
Mass	Kilogram	kg	Ton	t	10 <sup>-3</sup>
Force	Newton	N	Kilogram-force	kgf	1/9.806 65
			Ton-force	tf	1/ (9.806 65×10 <sup>3</sup> )
			Dyne	dyn	10 <sup>5</sup>
Torque or Moment	Newton · meter	N · m	Kilogram-force meter	kgf · m	1/9.806 65
Stress	Pascal	Pa (N/m <sup>2</sup> )	Kilogram-force per square centimeter	kgf/cm <sup>2</sup>	1/ (9.806 65×10 <sup>4</sup> )
			Kilogram-force per square millimeter	kgf/mm <sup>2</sup>	1/ (9.806 65×10 <sup>6</sup> )

Conversion Factors from SI Units (Continued)

Parameter	SI Units		Units other than SI		Conversion Factors from SI Units
	Names of Units	Symbols	Names of Units	Units	
Pressure	Pascal (Newton per square meter)	Pa (N/m <sup>2</sup> )	Kilogram-force per square meter	kgf/m <sup>2</sup>	1/9.806 65
			Water Column	mH <sub>2</sub> O	1/ (9.806 65×10 <sup>3</sup> )
			Mercury Column	mmHg	760/ (1.013 25×10 <sup>5</sup> )
			Torr	Torr	760/ (1.013 25×10 <sup>5</sup> )
			Bar	bar	10 <sup>-5</sup>
Energy	Joule (Newton · meter)	J (N · m)	Erg	erg	10 <sup>7</sup>
			Calorie (International)	cal <sub>IT</sub>	1/4.186 8
			Kilogram-force meter	kgf · m	1/9.806 65
			Kilowatt hour	kW · h	1/ (3.6×10 <sup>6</sup> )
			French horse power hour	PS · h	≈ 3.776 72×10 <sup>-7</sup>
Work	Watt (Joule per second)	W (J/s)	Kilogram-force meter per second	kgf · m/s	1/9.806 65
			Kilocalorie per hour	kcal/h	1/1.163
			French horse power	PS	≈ 1/735.498 8
Viscosity, Viscosity Index	Pascal second	Pa · s	Poise	P	10
			Kinematic Viscosity, Kinematic Viscosity Index	m <sup>2</sup> /s	Stokes Centistokes
Temperature	Kelvin, Degree celsius	K, °C	Degree	°C	(See note (1))
Electric Current, Magnetomotive Force	Ampere	A	Ampere	A	1
Voltage, Electromotive Force	Volt	V	(Watts per ampere)	(W/A)	1
Magnetic Field Strength	Ampere per meter	A/m	Oersted	Oe	4π/10 <sup>3</sup>
Magnetic Flux Density	Tesla	T	Gauss	Gs	10 <sup>4</sup>
			Gamma	γ	10 <sup>9</sup>
Electrical Resistance	Ohm	Ω	(Volts per ampere)	(V/A)	1

**Note** (1) The conversion from T K into θ °C is θ = T - 273.15 but for a temperature difference, it is ΔT = Δθ. However, ΔT and Δθ represent temperature differences measured using the Kelvin and Celsius scales respectively.

**Remarks** The names and symbols in ( ) are equivalent to those directly above them or on their left. Example of conversion 1N=1/9.806 65kgf

Appendix Table 2 N-kgf Conversion Table

[Method of using this table] For example, to convert 10N into kgf, read the figure in the right kgf column adjacent to the 10 in the center column in the 1st block. This means that 10N is 1.0197kgf. To convert 10kgf into N, read the figure in the left N column of the same row, which indicates that the answer is 98.066N.

$$1 \text{ N} = 0.1019716 \text{ kgf}$$

$$1 \text{ kgf} = 9.80665 \text{ N}$$

N		kgf	N		kgf	N		kgf
9.8066	<b>1</b>	0.1020	333.43	<b>34</b>	3.4670	657.05	<b>67</b>	6.8321
19.613	<b>2</b>	0.2039	343.23	<b>35</b>	3.5690	666.85	<b>68</b>	6.9341
29.420	<b>3</b>	0.3059	353.04	<b>36</b>	3.6710	676.66	<b>69</b>	7.0360
39.227	<b>4</b>	0.4079	362.85	<b>37</b>	3.7729	686.47	<b>70</b>	7.1380
49.033	<b>5</b>	0.5099	372.65	<b>38</b>	3.8749	696.27	<b>71</b>	7.2400
58.840	<b>6</b>	0.6118	382.46	<b>39</b>	3.9769	706.08	<b>72</b>	7.3420
68.647	<b>7</b>	0.7138	392.27	<b>40</b>	4.0789	715.89	<b>73</b>	7.4439
78.453	<b>8</b>	0.8158	402.07	<b>41</b>	4.1808	725.69	<b>74</b>	7.5459
88.260	<b>9</b>	0.9177	411.88	<b>42</b>	4.2828	735.50	<b>75</b>	7.6479
98.066	<b>10</b>	1.0197	421.69	<b>43</b>	4.3848	745.31	<b>76</b>	7.7498
107.87	<b>11</b>	1.1217	431.49	<b>44</b>	4.4868	755.11	<b>77</b>	7.8518
117.68	<b>12</b>	1.2237	441.30	<b>45</b>	4.5887	764.92	<b>78</b>	7.9538
127.49	<b>13</b>	1.3256	451.11	<b>46</b>	4.6907	774.73	<b>79</b>	8.0558
137.29	<b>14</b>	1.4276	460.91	<b>47</b>	4.7927	784.53	<b>80</b>	8.1577
147.10	<b>15</b>	1.5296	470.72	<b>48</b>	4.8946	794.34	<b>81</b>	8.2597
156.91	<b>16</b>	1.6315	480.53	<b>49</b>	4.9966	804.15	<b>82</b>	8.3617
166.71	<b>17</b>	1.7335	490.33	<b>50</b>	5.0986	813.95	<b>83</b>	8.4636
176.52	<b>18</b>	1.8355	500.14	<b>51</b>	5.2006	823.76	<b>84</b>	8.5656
186.33	<b>19</b>	1.9375	509.95	<b>52</b>	5.3025	833.57	<b>85</b>	8.6676
196.13	<b>20</b>	2.0394	519.75	<b>53</b>	5.4045	843.37	<b>86</b>	8.7696
205.94	<b>21</b>	2.1414	529.56	<b>54</b>	5.5065	853.18	<b>87</b>	8.8715
215.75	<b>22</b>	2.2434	539.37	<b>55</b>	5.6084	862.99	<b>88</b>	8.9735
225.55	<b>23</b>	2.3453	549.17	<b>56</b>	5.7104	872.79	<b>89</b>	9.0755
235.36	<b>24</b>	2.4473	558.98	<b>57</b>	5.8124	882.60	<b>90</b>	9.1774
245.17	<b>25</b>	2.5493	568.79	<b>58</b>	5.9144	892.41	<b>91</b>	9.2794
254.97	<b>26</b>	2.6513	578.59	<b>59</b>	6.0163	902.21	<b>92</b>	9.3814
264.78	<b>27</b>	2.7532	588.40	<b>60</b>	6.1183	912.02	<b>93</b>	9.4834
274.59	<b>28</b>	2.8552	598.21	<b>61</b>	6.2203	921.83	<b>94</b>	9.5853
284.39	<b>29</b>	2.9572	608.01	<b>62</b>	6.3222	931.63	<b>95</b>	9.6873
294.20	<b>30</b>	3.0591	617.82	<b>63</b>	6.4242	941.44	<b>96</b>	9.7893
304.01	<b>31</b>	3.1611	627.63	<b>64</b>	6.5262	951.25	<b>97</b>	9.8912
313.81	<b>32</b>	3.2631	637.43	<b>65</b>	6.6282	961.05	<b>98</b>	9.9932
323.62	<b>33</b>	3.3651	647.24	<b>66</b>	6.7301	970.86	<b>99</b>	10.095

Appendix Table 3 kg-lb Conversion Table

[Method of using this table] For example, to convert 10kg into lb, read the figure in the right lb column adjacent to the 10 in the center column in the 1st block. This means that 10kg is 22.046lb. To convert 10lb into kg, read the figure in the left kg column of the same row, which indicates that the answer is 4.536kg.

$$1 \text{ kg} = 2.2046226 \text{ lb}$$

$$1 \text{ lb} = 0.45359237 \text{ kg}$$

kg		lb	kg		lb	kg		lb
0.454	<b>1</b>	2.205	15.422	<b>34</b>	74.957	30.391	<b>67</b>	147.71
0.907	<b>2</b>	4.409	15.876	<b>35</b>	77.162	30.844	<b>68</b>	149.91
1.361	<b>3</b>	6.614	16.329	<b>36</b>	79.366	31.298	<b>69</b>	152.12
1.814	<b>4</b>	8.818	16.783	<b>37</b>	81.571	31.751	<b>70</b>	154.32
2.268	<b>5</b>	11.023	17.237	<b>38</b>	83.776	32.205	<b>71</b>	156.53
2.722	<b>6</b>	13.228	17.690	<b>39</b>	85.980	32.659	<b>72</b>	158.73
3.175	<b>7</b>	15.432	18.144	<b>40</b>	88.185	33.112	<b>73</b>	160.94
3.629	<b>8</b>	17.637	18.597	<b>41</b>	90.390	33.566	<b>74</b>	163.14
4.082	<b>9</b>	19.842	19.051	<b>42</b>	92.594	34.019	<b>75</b>	165.35
4.536	<b>10</b>	22.046	19.504	<b>43</b>	94.799	34.473	<b>76</b>	167.55
4.990	<b>11</b>	24.251	19.958	<b>44</b>	97.003	34.927	<b>77</b>	169.76
5.443	<b>12</b>	26.455	20.412	<b>45</b>	99.208	35.380	<b>78</b>	171.96
5.897	<b>13</b>	28.660	20.865	<b>46</b>	101.41	35.834	<b>79</b>	174.17
6.350	<b>14</b>	30.865	21.319	<b>47</b>	103.62	36.287	<b>80</b>	176.37
6.804	<b>15</b>	33.069	21.772	<b>48</b>	105.82	36.741	<b>81</b>	178.57
7.257	<b>16</b>	35.274	22.226	<b>49</b>	108.03	37.195	<b>82</b>	180.78
7.711	<b>17</b>	37.479	22.680	<b>50</b>	110.23	37.648	<b>83</b>	182.98
8.165	<b>18</b>	39.683	23.133	<b>51</b>	112.44	38.102	<b>84</b>	185.19
8.618	<b>19</b>	41.888	23.587	<b>52</b>	114.64	38.555	<b>85</b>	187.39
9.072	<b>20</b>	44.092	24.040	<b>53</b>	116.84	39.009	<b>86</b>	189.60
9.525	<b>21</b>	46.297	24.494	<b>54</b>	119.05	39.463	<b>87</b>	191.80
9.979	<b>22</b>	48.502	24.948	<b>55</b>	121.25	39.916	<b>88</b>	194.01
10.433	<b>23</b>	50.706	25.401	<b>56</b>	123.46	40.370	<b>89</b>	196.21
10.886	<b>24</b>	52.911	25.855	<b>57</b>	125.66	40.823	<b>90</b>	198.42
11.340	<b>25</b>	55.116	26.308	<b>58</b>	127.87	41.277	<b>91</b>	200.62
11.793	<b>26</b>	57.320	26.762	<b>59</b>	130.07	41.730	<b>92</b>	202.83
12.247	<b>27</b>	59.525	27.216	<b>60</b>	132.28	42.184	<b>93</b>	205.03
12.701	<b>28</b>	61.729	27.669	<b>61</b>	134.48	42.638	<b>94</b>	207.23
13.154	<b>29</b>	63.934	28.123	<b>62</b>	136.69	43.091	<b>95</b>	209.44
13.608	<b>30</b>	66.139	28.576	<b>63</b>	138.89	43.545	<b>96</b>	211.64
14.061	<b>31</b>	68.343	29.030	<b>64</b>	141.10	43.998	<b>97</b>	213.85
14.515	<b>32</b>	70.548	29.484	<b>65</b>	143.30	44.452	<b>98</b>	216.05
14.969	<b>33</b>	72.753	29.937	<b>66</b>	145.51	44.906	<b>99</b>	218.26

Appendix Table 4 °C-°F Conversion Table

[Method of using this table] For example, to convert 38°C into °F, read the figure in the right °F column adjacent to the 38 in the center column in the 2nd block. This means that 38°C is 100.4°F. To convert 38°F into °C, read the figure in the left °C column of the same row, which indicates that the answer is 3.3°C.

$$C = \frac{5}{9}(F - 32)$$

$$F = 32 + \frac{9}{5}C$$

°C		°F	°C		°F	°C		°F	°C		°F
-73.3	<b>-100</b>	-148.0	0.0	<b>32</b>	89.6	21.7	<b>71</b>	159.8	43.3	<b>110</b>	230
-62.2	<b>- 80</b>	-112.0	0.6	<b>33</b>	91.4	22.2	<b>72</b>	161.6	46.1	<b>115</b>	239
-51.1	<b>- 60</b>	- 76.0	1.1	<b>34</b>	93.2	22.8	<b>73</b>	163.4	48.9	<b>120</b>	248
-40.0	<b>- 40</b>	- 40.0	1.7	<b>35</b>	95.0	23.3	<b>74</b>	165.2	51.7	<b>125</b>	257
-34.4	<b>- 30</b>	- 22.0	2.2	<b>36</b>	96.8	23.9	<b>75</b>	167.0	54.4	<b>130</b>	266
-28.9	<b>- 20</b>	- 4.0	2.8	<b>37</b>	98.6	24.4	<b>76</b>	168.8	57.2	<b>135</b>	275
-23.3	<b>- 10</b>	14.0	3.3	<b>38</b>	100.4	25.0	<b>77</b>	170.6	60.0	<b>140</b>	284
-17.8	<b> 0</b>	32.0	3.9	<b>39</b>	102.2	25.6	<b>78</b>	172.4	65.6	<b>150</b>	302
-17.2	<b> 1</b>	33.8	4.4	<b>40</b>	104.0	26.1	<b>79</b>	174.2	71.1	<b>160</b>	320
-16.7	<b> 2</b>	35.6	5.0	<b>41</b>	105.8	26.7	<b>80</b>	176.0	76.7	<b>170</b>	338
-16.1	<b> 3</b>	37.4	5.6	<b>42</b>	107.6	27.2	<b>81</b>	177.8	82.2	<b>180</b>	356
-15.6	<b> 4</b>	39.2	6.1	<b>43</b>	109.4	27.8	<b>82</b>	179.6	87.8	<b>190</b>	374
-15.0	<b> 5</b>	41.0	6.7	<b>44</b>	111.2	28.3	<b>83</b>	181.4	93.3	<b>200</b>	392
-14.4	<b> 6</b>	42.8	7.2	<b>45</b>	113.0	28.9	<b>84</b>	183.2	98.9	<b>210</b>	410
-13.9	<b> 7</b>	44.6	7.8	<b>46</b>	114.8	29.4	<b>85</b>	185.0	104.4	<b>220</b>	428
-13.3	<b> 8</b>	46.4	8.3	<b>47</b>	116.6	30.0	<b>86</b>	186.8	110.0	<b>230</b>	446
-12.8	<b> 9</b>	48.2	8.9	<b>48</b>	118.4	30.6	<b>87</b>	188.6	115.6	<b>240</b>	464
-12.2	<b>10</b>	50.0	9.4	<b>49</b>	120.2	31.1	<b>88</b>	190.4	121.1	<b>250</b>	482
-11.7	<b>11</b>	51.8	10.0	<b>50</b>	122.0	31.7	<b>89</b>	192.2	148.9	<b>300</b>	572
-11.1	<b>12</b>	53.6	10.6	<b>51</b>	123.8	32.2	<b>90</b>	194.0	176.7	<b>350</b>	662
-10.6	<b>13</b>	55.4	11.1	<b>52</b>	125.6	32.8	<b>91</b>	195.8	204	<b>400</b>	752
-10.0	<b>14</b>	57.2	11.7	<b>53</b>	127.4	33.3	<b>92</b>	197.6	232	<b>450</b>	842
- 9.4	<b>15</b>	59.0	12.2	<b>54</b>	129.2	33.9	<b>93</b>	199.4	260	<b>500</b>	932
- 8.9	<b>16</b>	60.8	12.8	<b>55</b>	131.0	34.4	<b>94</b>	201.2	288	<b>550</b>	1022
- 8.3	<b>17</b>	62.6	13.3	<b>56</b>	132.8	35.0	<b>95</b>	203.0	316	<b>600</b>	1112
- 7.8	<b>18</b>	64.4	13.9	<b>57</b>	134.6	35.6	<b>96</b>	204.8	343	<b>650</b>	1202
- 7.2	<b>19</b>	66.2	14.4	<b>58</b>	136.4	36.1	<b>97</b>	206.6	371	<b>700</b>	1292
- 6.7	<b>20</b>	68.0	15.0	<b>59</b>	138.2	36.7	<b>98</b>	208.4	399	<b>750</b>	1382
- 6.1	<b>21</b>	69.8	15.6	<b>60</b>	140.0	37.2	<b>99</b>	210.2	427	<b>800</b>	1472
- 5.6	<b>22</b>	71.6	16.1	<b>61</b>	141.8	37.8	<b>100</b>	212.0	454	<b>850</b>	1562
- 5.0	<b>23</b>	73.4	16.7	<b>62</b>	143.6	38.3	<b>101</b>	213.8	482	<b>900</b>	1652
- 4.4	<b>24</b>	75.2	17.2	<b>63</b>	145.4	38.9	<b>102</b>	215.6	510	<b>950</b>	1742
- 3.9	<b>25</b>	77.0	17.8	<b>64</b>	147.2	39.4	<b>103</b>	217.4	538	<b>1000</b>	1832
- 3.3	<b>26</b>	78.8	18.3	<b>65</b>	149.0	40.0	<b>104</b>	219.2	593	<b>1100</b>	2012
- 2.8	<b>27</b>	80.6	18.9	<b>66</b>	150.8	40.6	<b>105</b>	221.0	649	<b>1200</b>	2192
- 2.2	<b>28</b>	82.4	19.4	<b>67</b>	152.6	41.1	<b>106</b>	222.8	704	<b>1300</b>	2372
- 1.7	<b>29</b>	84.2	20.0	<b>68</b>	154.4	41.7	<b>107</b>	224.6	760	<b>1400</b>	2552
- 1.1	<b>30</b>	86.0	20.6	<b>69</b>	156.2	42.2	<b>108</b>	226.4	816	<b>1500</b>	2732
- 0.6	<b>31</b>	87.8	21.1	<b>70</b>	158.0	42.8	<b>109</b>	228.2	871	<b>1600</b>	2912

Appendix Table 5 Viscosity Conversion Table

Kinematic Viscosity mm <sup>2</sup> /s	Saybolt Universal SUS (sec)		No.1 Type Redwood R (sec)		Engler E (degree)	Kinematic Viscosity mm <sup>2</sup> /s	Saybolt Universal SUS (sec)		No.1 Type Redwood R (sec)		Engler E (degree)
	100°F	210°F	50°C	100°C			100°F	210°F	50°C	100°C	
<b>2</b>	32.6	32.8	30.8	31.2	1.14	<b>35</b>	163	164	144	147	4.70
<b>3</b>	36.0	36.3	33.3	33.7	1.22	<b>36</b>	168	170	148	151	4.83
<b>4</b>	39.1	39.4	35.9	36.5	1.31	<b>37</b>	172	173	153	155	4.96
<b>5</b>	42.3	42.6	38.5	39.1	1.40	<b>38</b>	177	178	156	159	5.08
<b>6</b>	45.5	45.8	41.1	41.7	1.48	<b>39</b>	181	183	160	164	5.21
<b>7</b>	48.7	49.0	43.7	44.3	1.56	<b>40</b>	186	187	164	168	5.34
<b>8</b>	52.0	52.4	46.3	47.0	1.65	<b>41</b>	190	192	168	172	5.47
<b>9</b>	55.4	55.8	49.1	50.0	1.75	<b>42</b>	195	196	172	176	5.59
<b>10</b>	58.8	59.2	52.1	52.9	1.84	<b>43</b>	199	201	176	180	5.72
<b>11</b>	62.3	62.7	55.1	56.0	1.93	<b>44</b>	204	205	180	185	5.85
<b>12</b>	65.9	66.4	58.2	59.1	2.02	<b>45</b>	208	210	184	189	5.98
<b>13</b>	69.6	70.1	61.4	62.3	2.12	<b>46</b>	213	215	188	193	6.11
<b>14</b>	73.4	73.9	64.7	65.6	2.22	<b>47</b>	218	219	193	197	6.24
<b>15</b>	77.2	77.7	68.0	69.1	2.32	<b>48</b>	222	224	197	202	6.37
<b>16</b>	81.1	81.7	71.5	72.6	2.43	<b>49</b>	227	228	201	206	6.50
<b>17</b>	85.1	85.7	75.0	76.1	2.54	<b>50</b>	231	233	205	210	6.63
<b>18</b>	89.2	89.8	78.6	79.7	2.64	<b>55</b>	254	256	225	231	7.24
<b>19</b>	93.3	94.0	82.1	83.6	2.76	<b>60</b>	277	279	245	252	7.90
<b>20</b>	97.5	98.2	85.8	87.4	2.87	<b>65</b>	300	302	266	273	8.55
<b>21</b>	102	102	89.5	91.3	2.98	<b>70</b>	323	326	286	294	9.21
<b>22</b>	106	107	93.3	95.1	3.10	<b>75</b>	346	349	306	315	9.89
<b>23</b>	110	111	97.1	98.9	3.22	<b>80</b>	371	373	326	336	10.5
<b>24</b>	115	115	101	103	3.34	<b>85</b>	394	397	347	357	11.2
<b>25</b>	119	120	105	107	3.46	<b>90</b>	417	420	367	378	11.8
<b>26</b>	123	124	109	111	3.58	<b>95</b>	440	443	387	399	12.5
<b>27</b>	128	129	112	115	3.70	<b>100</b>	464	467	408	420	13.2
<b>28</b>	132	133	116	119	3.82	<b>120</b>	556	560	490	504	15.8
<b>29</b>	137	138	120	123	3.95	<b>140</b>	649	653	571	588	18.4
<b>30</b>	141	142	124	127	4.07	<b>160</b>	742	747	653	672	21.1
<b>31</b>	145	146	128	131	4.20	<b>180</b>	834	840	734	757	23.7
<b>32</b>	150	150	132	135	4.32	<b>200</b>	927	933	816	841	26.3
<b>33</b>	154	155	136	139	4.45	<b>250</b>	1 159	1 167	1 020	1 051	32.9
<b>34</b>	159	160	140	143	4.57	<b>300</b>	1 391	1 400	1 224	1 241	39.5

Remarks 1mm<sup>2</sup>/s=1cSt

Appendix Table 6 inch - mm Conversion Table

1" = 25.4mm

inch	0	1	2	3	4	5	6	7	8	9	10	
Fraction Decimal	mm											
<b>0</b>	<b>0.00000</b>	<b>0.000</b>	<b>25.400</b>	<b>50.800</b>	<b>76.200</b>	<b>101.600</b>	<b>127.000</b>	<b>152.400</b>	<b>177.800</b>	<b>203.200</b>	<b>228.600</b>	<b>254.000</b>
1/64	0.015625	0.397	25.797	51.197	76.597	101.997	127.397	152.797	178.197	203.597	228.997	254.397
1/32	0.031250	0.794	26.194	51.594	76.994	102.394	127.794	153.194	178.594	203.994	229.394	254.794
3/64	0.046875	1.191	26.591	51.991	77.391	102.791	128.191	153.591	178.991	204.391	229.791	255.191
<b>1/16</b>	<b>0.062500</b>	<b>1.588</b>	<b>26.988</b>	<b>52.388</b>	<b>77.788</b>	<b>103.188</b>	<b>128.588</b>	<b>153.988</b>	<b>179.388</b>	<b>204.788</b>	<b>230.188</b>	<b>255.588</b>
5/64	0.078125	1.984	27.384	52.784	78.184	103.584	128.984	154.384	179.784	205.184	230.584	255.984
3/32	0.093750	2.381	27.781	53.181	78.581	103.981	129.381	154.781	180.181	205.581	230.981	256.381
7/64	0.109375	2.778	28.178	53.578	78.978	104.378	129.778	155.178	180.578	205.978	231.378	256.778
<b>1/8</b>	<b>0.125000</b>	<b>3.175</b>	<b>28.575</b>	<b>53.975</b>	<b>79.375</b>	<b>104.775</b>	<b>130.175</b>	<b>155.575</b>	<b>180.975</b>	<b>206.375</b>	<b>231.775</b>	<b>257.175</b>
9/64	0.140625	3.572	28.972	54.372	79.772	105.172	130.572	155.972	181.372	206.772	232.172	257.572
5/32	0.156250	3.969	29.369	54.769	80.169	105.569	130.969	156.369	181.769	207.169	232.569	257.969
11/64	0.171875	4.366	29.766	55.166	80.566	105.966	131.366	156.766	182.166	207.566	232.966	258.366
<b>3/16</b>	<b>0.187500</b>	<b>4.762</b>	<b>30.162</b>	<b>55.562</b>	<b>80.962</b>	<b>106.362</b>	<b>131.762</b>	<b>157.162</b>	<b>182.562</b>	<b>207.962</b>	<b>233.362</b>	<b>258.762</b>
13/64	0.203125	5.159	30.559	55.959	81.359	106.759	132.159	157.559	182.959	208.359	233.759	259.159
7/32	0.218750	5.556	30.956	56.356	81.756	107.156	132.556	157.956	183.356	208.756	234.156	259.556
15/64	0.234375	5.953	31.353	56.753	82.153	107.553	132.953	158.353	183.753	209.153	234.553	259.953
<b>1/4</b>	<b>0.250000</b>	<b>6.350</b>	<b>31.750</b>	<b>57.150</b>	<b>82.550</b>	<b>107.950</b>	<b>133.350</b>	<b>158.750</b>	<b>184.150</b>	<b>209.550</b>	<b>234.950</b>	<b>260.350</b>
17/64	0.265625	6.747	32.147	57.547	82.947	108.347	133.747	159.147	184.547	209.947	235.347	260.747
9/32	0.281250	7.144	32.544	57.944	83.344	108.744	134.144	159.544	184.944	210.344	235.744	261.144
19/64	0.296875	7.541	32.941	58.341	83.741	109.141	134.541	159.941	185.341	210.741	236.141	261.541
<b>5/16</b>	<b>0.312500</b>	<b>7.938</b>	<b>33.338</b>	<b>58.738</b>	<b>84.138</b>	<b>109.538</b>	<b>134.938</b>	<b>160.338</b>	<b>185.738</b>	<b>211.138</b>	<b>236.538</b>	<b>261.938</b>
21/64	0.328125	8.334	33.734	59.134	84.534	109.934	135.334	160.734	186.134	211.534	236.934	262.334
11/32	0.343750	8.731	34.131	59.531	84.931	110.331	135.731	161.131	186.531	211.931	237.331	262.731
23/64	0.359375	9.128	34.528	59.928	85.328	110.728	136.128	161.528	186.928	212.328	237.728	263.128
<b>3/8</b>	<b>0.375000</b>	<b>9.525</b>	<b>34.925</b>	<b>60.325</b>	<b>85.725</b>	<b>111.125</b>	<b>136.525</b>	<b>161.925</b>	<b>187.325</b>	<b>212.725</b>	<b>238.125</b>	<b>263.525</b>
25/64	0.390625	9.922	35.322	60.722	86.122	111.522	136.922	162.322	187.722	213.122	238.522	263.922
13/32	0.406250	10.319	35.719	61.119	86.519	111.919	137.319	162.719	188.119	213.519	238.919	264.319
27/64	0.421875	10.716	36.116	61.516	86.916	112.316	137.716	163.116	188.516	213.916	239.316	264.716
<b>7/16</b>	<b>0.437500</b>	<b>11.112</b>	<b>36.512</b>	<b>61.912</b>	<b>87.312</b>	<b>112.712</b>	<b>138.112</b>	<b>163.512</b>	<b>188.912</b>	<b>214.312</b>	<b>239.712</b>	<b>265.112</b>
29/64	0.453125	11.509	36.909	62.309	87.709	113.109	138.509	163.909	189.309	214.709	240.109	265.509
15/32	0.468750	11.906	37.306	62.706	88.106	113.506	138.906	164.306	189.706	215.106	240.506	265.906
31/64	0.484375	12.303	37.703	63.103	88.503	113.903	139.303	164.703	190.103	215.503	240.903	266.303
<b>1/2</b>	<b>0.500000</b>	<b>12.700</b>	<b>38.100</b>	<b>63.500</b>	<b>88.900</b>	<b>114.300</b>	<b>139.700</b>	<b>165.100</b>	<b>190.500</b>	<b>215.900</b>	<b>241.300</b>	<b>266.700</b>
33/64	0.515625	13.097	38.497	63.897	89.297	114.697	140.097	165.497	190.897	216.297	241.697	267.097
17/32	0.531250	13.494	38.894	64.294	89.694	115.094	140.494	165.894	191.294	216.694	242.094	267.494
35/64	0.546875	13.891	39.291	64.691	90.091	115.491	140.891	166.291	191.691	217.091	242.491	267.891
<b>9/16</b>	<b>0.562500</b>	<b>14.288</b>	<b>39.688</b>	<b>65.088</b>	<b>90.488</b>	<b>115.888</b>	<b>141.288</b>	<b>166.688</b>	<b>192.088</b>	<b>217.488</b>	<b>242.888</b>	<b>268.288</b>
37/64	0.578125	14.684	40.084	65.484	90.884	116.284	141.684	167.084	192.484	217.884	243.284	268.684
19/32	0.593750	15.081	40.481	65.881	91.281	116.681	142.081	167.481	192.881	218.281	243.681	269.081
39/64	0.609375	15.478	40.878	66.278	91.678	117.078	142.478	167.878	193.278	218.678	244.078	269.478
<b>5/8</b>	<b>0.625000</b>	<b>15.875</b>	<b>41.275</b>	<b>66.675</b>	<b>92.075</b>	<b>117.475</b>	<b>142.875</b>	<b>168.275</b>	<b>193.675</b>	<b>219.075</b>	<b>244.475</b>	<b>269.875</b>
41/64	0.640625	16.272	41.672	67.072	92.472	117.872	143.272	168.672	194.072	219.472	244.872	270.272
21/32	0.656250	16.669	42.069	67.469	92.869	118.269	143.669	169.069	194.469	219.869	245.269	270.669
43/64	0.671875	17.066	42.466	67.866	93.266	118.666	144.066	169.466	194.866	220.266	245.666	271.066
<b>11/16</b>	<b>0.687500</b>	<b>17.462</b>	<b>42.862</b>	<b>68.262</b>	<b>93.662</b>	<b>119.062</b>	<b>144.462</b>	<b>169.862</b>	<b>195.262</b>	<b>220.662</b>	<b>246.062</b>	<b>271.462</b>
45/64	0.703125	17.859	43.259	68.659	94.059	119.459	144.859	170.259	195.659	221.059	246.459	271.859
23/32	0.718750	18.256	43.656	69.056	94.456	119.856	145.256	170.656	196.056	221.456	246.856	272.256
47/64	0.734375	18.653	44.053	69.453	94.853	120.253	145.653	171.053	196.453	221.853	247.253	272.653
<b>3/4</b>	<b>0.750000</b>	<b>19.050</b>	<b>44.450</b>	<b>69.850</b>	<b>95.250</b>	<b>120.650</b>	<b>146.050</b>	<b>171.450</b>	<b>196.850</b>	<b>222.250</b>	<b>247.650</b>	<b>273.050</b>
49/64	0.765625	19.447	44.847	70.247	95.647	121.047	146.447	171.847	197.247	222.647	248.047	273.447
25/32	0.781250	19.844	45.244	70.644	96.044	121.444	146.844	172.244	197.644	223.044	248.444	273.844
51/64	0.796875	20.241	45.641	71.041	96.441	121.841	147.241	172.641	198.041	223.441	248.841	274.241
<b>13/16</b>	<b>0.812500</b>	<b>20.638</b>	<b>46.038</b>	<b>71.438</b>	<b>96.838</b>	<b>122.238</b>	<b>147.638</b>	<b>173.038</b>	<b>198.438</b>	<b>223.838</b>	<b>249.238</b>	<b>274.638</b>
53/64	0.828125	21.034	46.434	71.834	97.234	122.634	148.034	173.434	198.834	224.234	249.634	275.034
27/32	0.843750	21.431	46.831	72.231	97.631	123.031	148.431	173.831	199.231	224.631	250.031	275.431
55/64	0.859375	21.828	47.228	72.628	98.028	123.428	148.828	174.228	199.628	225.028	250.428	275.828
<b>7/8</b>	<b>0.875000</b>	<b>22.225</b>	<b>47.625</b>	<b>73.025</b>	<b>98.425</b>	<b>123.825</b>	<b>149.225</b>	<b>174.625</b>	<b>200.025</b>	<b>225.425</b>	<b>250.825</b>	<b>276.225</b>
57/64	0.890625	22.622	48.022	73.422	98.822	124.222	149.622	175.022	200.422	225.822	251.222	276.622
29/32	0.906250	23.019	48.419	73.819	99.219	124.619	150.019	175.419	200.819	226.219	251.619	277.019
59/64	0.921875	23.416	48.816	74.216	99.616	125.016	150.416	175.816	201.216	226.616	252.016	277.416
<b>15/16</b>	<b>0.937500</b>	<b>23.812</b>	<b>49.212</b>	<b>74.612</b>	<b>100.012</b>	<b>125.412</b>	<b>150.812</b>	<b>176.212</b>	<b>201.612</b>	<b>227.012</b>	<b>252.412</b>	<b>277.812</b>
61/64	0.953125	24.209	49.609	75.009	100.409	125.809	151.209	176.609	202.009	227.409	252.809	278.209
31/32	0.968750	24.606	50.006	75.406	100.806	126.206	151.606	177.006	202.406	227.806	253.206	278.606
63/64	0.984375	25.003	50.403	75.803	101.203	126.603	152.003	177.403	202.803	228.203	253.603	279.003

1" = 25.4mm

inch	11	12	13	14	15	16	17	18	19	20
Fraction Decimal	mm									
<b>0</b>	<b>0.0000</b>	<b>279.400</b>	<b>304.800</b>	<b>330.2</b>						

Appendix Table 7 Hardness Conversion Table (Reference)

Rockwell C Scale Hardness (1 471N {150kgf})	Vickers Hardness	Brinell Hardness		Rockwell Hardness		Shore Hardness
		Standard Ball	Tungsten Carbide Ball	A Scale Load <sup>588.4N</sup> {60kgf} Brake Indenter	B Scale Load <sup>980.7N</sup> {100kgf} 1.588mm Ball (1/16in)	
68	940	—	—	85.6	—	97
67	900	—	—	85.0	—	95
66	865	—	—	84.5	—	92
65	832	—	739	83.9	—	91
64	800	—	722	83.4	—	88
63	772	—	705	82.8	—	87
62	746	—	688	82.3	—	85
61	720	—	670	81.8	—	83
60	697	—	654	81.2	—	81
59	674	—	634	80.7	—	80
58	653	—	615	80.1	—	78
57	633	—	595	79.6	—	76
56	613	—	577	79.0	—	75
55	595	—	560	78.5	—	74
54	577	—	543	78.0	—	72
53	560	—	525	77.4	—	71
52	544	500	512	76.8	—	69
51	528	487	496	76.3	—	68
50	513	475	481	75.9	—	67
49	498	464	469	75.2	—	66
48	484	451	455	74.7	—	64
47	471	442	443	74.1	—	63
46	458	432	432	73.6	—	62
45	446	421	421	73.1	—	60
44	434	409	409	72.5	—	58
43	423	400	400	72.0	—	57
42	412	390	390	71.5	—	56
41	402	381	381	70.9	—	55
40	392	371	371	70.4	—	54
39	382	362	362	69.9	—	52
38	372	353	353	69.4	—	51
37	363	344	344	68.9	—	50
36	354	336	336	68.4	(109.0)	49
35	345	327	327	67.9	(108.5)	48
34	336	319	319	67.4	(108.0)	47
33	327	311	311	66.8	(107.5)	46
32	318	301	301	66.3	(107.0)	44
31	310	294	294	65.8	(106.0)	43
30	302	286	286	65.3	(105.5)	42
29	294	279	279	64.7	(104.5)	41
28	286	271	271	64.3	(104.0)	41
27	279	264	264	63.8	(103.0)	40
26	272	258	258	63.3	(102.5)	38
25	266	253	253	62.8	(101.5)	38
24	260	247	247	62.4	(101.0)	37
23	254	243	243	62.0	100.0	36
22	248	237	237	61.5	99.0	35
21	243	231	231	61.0	98.5	35
20	238	226	226	60.5	97.8	34
(18)	230	219	219	—	96.7	33
(16)	222	212	212	—	95.5	32
(14)	213	203	203	—	93.9	31
(12)	204	194	194	—	92.3	29
(10)	196	187	187	—	90.7	28
(8)	188	179	179	—	89.5	27
(6)	180	171	171	—	87.1	26
(4)	173	165	165	—	85.5	25
(2)	166	158	158	—	83.5	24
(0)	160	152	152	—	81.7	24

Appendix Table 8 Physical and Mechanical Properties of Materials

Materials	Specific Gravity	Coefficient of Linear Expansion (0°~100°C)	Hardness (Brinell)	Modulus of Linear Elasticity (MPa) {kgf/mm <sup>2</sup> }	Tensile Strength (MPa) {kgf/mm <sup>2</sup> }	Yield Point (MPa) {kgf/mm <sup>2</sup> }	Elongation (%)
Bearing Steel (hardened)	7.83	12.5×10 <sup>-6</sup>	650~740	208 000 {21 200}	1 570~1 960 {160~200}	—	—
Martensitic Stainless Steel SUS 440C	7.68	10.1×10 <sup>-6</sup>	580	200 000 {20 400}	1 960 {200}	1 860 {190}	—
Mild Steel (C=0.12~0.20%)	7.86	11.6×10 <sup>-6</sup>	100~130	206 000 {21 000}	373~471 {38~48}	216~294 {22~30}	24~36
Hard Steel (C=0.3~0.5%)	7.84	11.3×10 <sup>-6</sup>	160~200	206 000 {21 000}	539~686 {55~70}	333~451 {34~46}	14~26
Austenitic Stainless Steel SUS 304	8.03	16.3×10 <sup>-6</sup>	150	193 000 {19 700}	588 {60}	245 {25}	60
Cast Iron	Gray Iron FC200	7.3	10.4×10 <sup>-6</sup>	223	98 100 {10 000}	More than 200 {20}	—
	Spheroidal graphite Iron FCD400	7.0	11.7×10 <sup>-6</sup>	Less than 201		More than 400 {41}	—
Aluminum	2.69	23.7×10 <sup>-6</sup>	15~26	70 600 {7 200}	78 {8}	34 {3.5}	35
Zinc	7.14	31×10 <sup>-6</sup>	30~60	92 200 {9 400}	147 {15}	—	30~40
Copper	8.93	16.2×10 <sup>-6</sup>	50	123 000 {12 500}	196 {20}	69 {7}	15~20
Brass	(Annealed)	8.5	19.1×10 <sup>-6</sup>	103 000 {10 500}	294~343 {30~35}	—	65~75
	(Machined)				363~539 {37~55}	—	15~50

**Remarks** The hardness of hardened bearing steel and martensitic stainless steel is usually expressed using the Rockwell C Scale, but for comparison, it is converted into Brinell hardness.



Appendix Table 9 Tolerances

Diameter Classification (mm)		Single Plane Mean S. D. Deviation (Normal) $Z_{dmp}$	d6	e6	f6	g5	g6	h5	h6	h7	h8	h9	h10	js5	js6
over	incl														
3	6	0 - 8	- 30 - 38	- 20 - 28	- 10 - 18	- 4 - 4 - 9 - 12	0 0 - 5 - 8	0 0 - 12 - 18	0 0 - 30 - 48	± 2.5	± 4				
6	10	0 - 8	- 40 - 49	- 25 - 34	- 13 - 22	- 5 - 5 - 11 - 14	0 0 - 6 - 9	0 0 - 15 - 22	0 0 - 36 - 58	± 3	± 4.5				
10	18	0 - 8	- 50 - 61	- 32 - 43	- 16 - 27	- 6 - 6 - 14 - 17	0 0 - 8 - 11	0 0 - 18 - 27	0 0 - 43 - 70	± 4	± 5.5				
18	30	0 - 10	- 65 - 78	- 40 - 53	- 20 - 33	- 7 - 7 - 16 - 20	0 0 - 9 - 13	0 0 - 21 - 33	0 0 - 52 - 84	± 4.5	± 6.5				
30	50	0 - 12	- 80 - 96	- 50 - 66	- 25 - 41	- 9 - 9 - 20 - 25	0 0 - 11 - 16	0 0 - 25 - 39	0 0 - 62 - 100	± 5.5	± 8				
50	80	0 - 15	- 100 - 119	- 60 - 79	- 30 - 49	- 10 - 10 - 23 - 29	0 0 - 13 - 19	0 0 - 30 - 46	0 0 - 74 - 120	± 6.5	± 9.5				
80	120	0 - 20	- 120 - 142	- 72 - 94	- 36 - 58	- 12 - 12 - 27 - 34	0 0 - 15 - 22	0 0 - 35 - 54	0 0 - 87 - 140	± 7.5	± 11				
120	180	0 - 25	- 145 - 170	- 85 - 110	- 43 - 68	- 14 - 14 - 32 - 39	0 0 - 18 - 25	0 0 - 40 - 63	0 0 - 100 - 160	± 9	± 12.5				
180	250	0 - 30	- 170 - 199	- 100 - 129	- 50 - 79	- 15 - 15 - 35 - 44	0 0 - 20 - 29	0 0 - 46 - 72	0 0 - 115 - 185	± 10	± 14.5				
250	315	0 - 35	- 190 - 222	- 110 - 142	- 56 - 88	- 17 - 17 - 40 - 49	0 0 - 23 - 32	0 0 - 52 - 81	0 0 - 130 - 210	± 11.5	± 16				
315	400	0 - 40	- 210 - 246	- 125 - 161	- 62 - 98	- 18 - 18 - 43 - 54	0 0 - 25 - 36	0 0 - 57 - 89	0 0 - 140 - 230	± 12.5	± 18				
400	500	0 - 45	- 230 - 270	- 135 - 175	- 68 - 108	- 20 - 20 - 47 - 60	0 0 - 27 - 40	0 0 - 63 - 97	0 0 - 155 - 250	± 13.5	± 20				
500	630	0 - 50	- 260 - 304	- 145 - 189	- 76 - 120	- 22 - 66	0 0 - 44 - 70	0 0 - 110 - 175	0 0 - 280	—	± 22				
630	800	0 - 75	- 290 - 340	- 160 - 210	- 80 - 130	- 24 - 74	0 0 - 50 - 80	0 0 - 125 - 200	0 0 - 320	—	± 25				
800	1 000	0 - 100	- 320 - 376	- 170 - 226	- 86 - 142	- 26 - 82	0 0 - 56 - 90	0 0 - 140 - 230	0 0 - 360	—	± 28				
1 000	1 250	0 - 125	- 350 - 416	- 195 - 261	- 98 - 164	- 28 - 94	0 0 - 66 - 105	0 0 - 165 - 260	0 0 - 420	—	± 33				
1 250	1 600	0 - 160	- 390 - 468	- 220 - 298	- 110 - 188	- 30 - 108	0 0 - 78 - 125	0 0 - 195 - 310	0 0 - 500	—	± 39				
1 600	2 000	0 - 200	- 430 - 522	- 240 - 332	- 120 - 212	- 32 - 124	0 0 - 92 - 150	0 0 - 230 - 370	0 0 - 600	—	± 46				

for Shaft Diameters

Units :  $\mu\text{m}$

j5	j6	j7	k5	k6	k7	m5	m6	n6	p6	r6	r7	Diameter Classification (mm)	
												over	incl
- 3 - 2	- 6 - 2	- 8 - 4	+ 6 + 1	+ 9 + 1	+ 13 + 1	+ 9 + 4	+ 12 + 4	+ 16 + 8	+ 20 + 12	+ 23 + 15	+ 27 + 15	3	6
+ 4 - 2	+ 7 - 2	+ 10 - 5	+ 7 + 1	+ 10 + 1	+ 16 + 1	+ 12 + 6	+ 15 + 6	+ 19 + 10	+ 24 + 15	+ 28 + 19	+ 34 + 19	6	10
+ 5 - 3	+ 8 - 3	+ 12 - 6	+ 9 + 1	+ 12 + 1	+ 19 + 1	+ 15 + 7	+ 18 + 7	+ 23 + 12	+ 29 + 18	+ 34 + 23	+ 41 + 23	10	18
+ 5 - 4	+ 9 - 4	+ 13 - 8	+ 11 + 2	+ 15 + 2	+ 23 + 2	+ 17 + 8	+ 21 + 8	+ 28 + 15	+ 35 + 22	+ 41 + 28	+ 49 + 28	18	30
+ 6 - 5	+ 11 - 5	+ 15 - 10	+ 13 + 2	+ 18 + 2	+ 27 + 2	+ 20 + 9	+ 25 + 9	+ 33 + 17	+ 42 + 26	+ 50 + 34	+ 59 + 34	30	50
+ 6 - 7	+ 12 - 7	+ 18 - 12	+ 15 + 2	+ 21 + 2	+ 32 + 2	+ 24 + 11	+ 30 + 11	+ 39 + 20	+ 51 + 32	+ 60 + 41	+ 71 + 41	50	65
+ 6 - 9	+ 13 - 9	+ 20 - 15	+ 18 + 3	+ 25 + 3	+ 38 + 3	+ 28 + 13	+ 35 + 13	+ 45 + 23	+ 59 + 37	+ 73 + 51	+ 86 + 51	80	100
+ 7 - 11	+ 14 - 11	+ 22 - 18	+ 21 + 3	+ 28 + 3	+ 43 + 3	+ 33 + 15	+ 40 + 15	+ 52 + 27	+ 68 + 43	+ 88 + 63	+ 103 + 63	120	140
+ 7 - 13	+ 16 - 13	+ 25 - 21	+ 24 + 4	+ 33 + 4	+ 50 + 4	+ 37 + 17	+ 46 + 17	+ 60 + 31	+ 79 + 50	+ 109 + 80	+ 126 + 80	200	225
+ 7 - 16	± 16	± 26	+ 27 + 4	+ 36 + 4	+ 56 + 4	+ 43 + 20	+ 52 + 20	+ 66 + 34	+ 88 + 56	+ 126 + 94	+ 146 + 94	250	280
+ 7 - 18	± 18	+ 29 - 28	+ 29 + 4	+ 40 + 4	+ 61 + 4	+ 46 + 21	+ 57 + 21	+ 73 + 37	+ 98 + 62	+ 144 + 108	+ 165 + 108	315	355
+ 7 - 20	± 20	+ 31 - 32	+ 32 + 5	+ 45 + 5	+ 68 + 5	+ 50 + 23	+ 63 + 23	+ 80 + 40	+ 108 + 68	+ 166 + 126	+ 189 + 126	400	450
—	—	—	—	+ 44 0	+ 70 0	—	+ 70 + 26	+ 88 + 44	+ 122 + 78	+ 194 + 150	+ 220 + 150	500	560
—	—	—	—	+ 50 0	+ 80 0	—	+ 80 + 30	+ 100 + 50	+ 138 + 88	+ 225 + 175	+ 255 + 175	630	710
—	—	—	—	+ 56 0	+ 90 0	—	+ 90 + 34	+ 112 + 56	+ 156 + 100	+ 266 + 210	+ 300 + 210	800	900
—	—	—	—	+ 66 0	+ 105 0	—	+ 106 + 40	+ 132 + 66	+ 186 + 120	+ 316 + 250	+ 355 + 250	1 000	1 120
—	—	—	—	+ 78 0	+ 125 0	—	+ 126 + 48	+ 156 + 78	+ 218 + 140	+ 408 + 330	+ 455 + 330	1 250	1 400
—	—	—	—	+ 92 0	+ 150 0	—	+ 150 + 58	+ 184 + 92	+ 262 + 170	+ 462 + 370	+ 520 + 370	1 600	1 800
—	—	—	—	+ 92 0	+ 150 0	—	+ 150 + 58	+ 184 + 92	+ 262 + 170	+ 492 + 400	+ 550 + 400	1 800	2 000

Appendix Table 10

Diameter Classification (mm)		Single Plane Mean S.D. Deviation (Normal) $\Delta D_{mp}$	E6	F6	F7	G6	G7	H6	H7	H8	J6	J7	JS6	JS7
over	incl													
10	18	0 - 8	+ 43 + 32	+ 27 + 16	+ 34 + 16	+ 17 + 6	+ 24 + 6	+ 11 0	+ 18 0	+ 27 0	+ 6 - 5	+ 10 - 8	± 5.5	± 9
18	30	0 - 9	+ 53 + 40	+ 33 + 20	+ 41 + 20	+ 20 + 7	+ 28 + 7	+ 13 0	+ 21 0	+ 33 0	+ 8 - 5	+ 12 - 9	± 6.5	± 10.5
30	50	0 - 11	+ 66 + 50	+ 41 + 25	+ 50 + 25	+ 25 + 9	+ 34 + 9	+ 16 0	+ 25 0	+ 39 0	+ 10 - 6	+ 14 - 11	± 8	± 12.5
50	80	0 - 13	+ 79 + 60	+ 49 + 30	+ 60 + 30	+ 29 + 10	+ 40 + 10	+ 19 0	+ 30 0	+ 46 0	+ 13 - 6	+ 18 - 12	± 9.5	± 15
80	120	0 - 15	+ 94 + 72	+ 58 + 36	+ 71 + 36	+ 34 + 12	+ 47 + 12	+ 22 0	+ 35 0	+ 54 0	+ 16 - 6	+ 22 - 13	± 11	± 17.5
120	150	0 - 18	+ 110 + 85	+ 68 + 43	+ 83 + 43	+ 39 + 14	+ 54 + 14	+ 25 0	+ 40 0	+ 63 0	+ 18 - 7	+ 26 - 14	± 12.5	± 20
150	180	0 - 25	+ 110 + 85	+ 68 + 43	+ 83 + 43	+ 39 + 14	+ 54 + 14	+ 25 0	+ 40 0	+ 63 0	+ 18 - 7	+ 26 - 14	± 12.5	± 20
180	250	0 - 30	+ 129 + 100	+ 79 + 50	+ 96 + 50	+ 44 + 15	+ 61 + 15	+ 29 0	+ 46 0	+ 72 0	+ 22 - 7	+ 30 - 16	± 14.5	± 23
250	315	0 - 35	+ 142 + 110	+ 88 + 56	+ 108 + 56	+ 49 + 17	+ 69 + 17	+ 32 0	+ 52 0	+ 81 0	+ 25 - 7	+ 36 - 16	± 16	± 26
315	400	0 - 40	+ 161 + 125	+ 98 + 62	+ 119 + 62	+ 54 + 18	+ 75 + 18	+ 36 0	+ 57 0	+ 89 0	+ 29 - 7	+ 39 - 18	± 18	± 28.5
400	500	0 - 45	+ 175 + 135	+ 108 + 68	+ 131 + 68	+ 60 + 20	+ 83 + 20	+ 40 0	+ 63 0	+ 97 0	+ 33 - 7	+ 43 - 20	± 20	± 31.5
500	630	0 - 50	+ 189 + 145	+ 120 + 76	+ 146 + 76	+ 66 + 22	+ 92 + 22	+ 44 0	+ 70 0	+ 110 0	—	—	± 22	± 35
630	800	0 - 75	+ 210 + 160	+ 130 + 80	+ 160 + 80	+ 74 + 24	+ 104 + 24	+ 50 0	+ 80 0	+ 125 0	—	—	± 25	± 40
800	1 000	0 - 100	+ 226 + 170	+ 142 + 86	+ 176 + 86	+ 82 + 26	+ 116 + 26	+ 56 0	+ 90 0	+ 140 0	—	—	± 28	± 45
1 000	1 250	0 - 125	+ 261 + 195	+ 164 + 98	+ 203 + 98	+ 94 + 28	+ 133 + 28	+ 66 0	+ 105 0	+ 165 0	—	—	± 33	± 52.5
1 250	1 600	0 - 160	+ 298 + 220	+ 188 + 110	+ 235 + 110	+ 108 + 30	+ 155 + 30	+ 78 0	+ 125 0	+ 195 0	—	—	± 39	± 62.5
1 600	2 000	0 - 200	+ 332 + 240	+ 212 + 120	+ 270 + 120	+ 124 + 32	+ 182 + 32	+ 92 0	+ 150 0	+ 230 0	—	—	± 46	± 75
2 000	2 500	0 - 250	+ 370 + 260	+ 240 + 130	+ 305 + 130	+ 144 + 34	+ 209 + 34	+ 110 0	+ 175 0	+ 280 0	—	—	± 55	± 87.5

Tolerances for Housing Bore Diameters

Units :  $\mu\text{m}$

K5	K6	K7	M5	M6	M7	N5	N6	N7	P6	P7	Diameter Classification (mm)	
											over	incl
+ 2 - 6	+ 2 - 9	+ 6 - 12	- 4 - 12	- 4 - 15	0 - 18	- 9 - 17	- 9 - 20	- 5 - 23	- 15 - 26	- 11 - 29	10	18
+ 1 - 8	+ 2 - 11	+ 6 - 15	- 5 - 14	- 4 - 17	0 - 21	- 12 - 21	- 11 - 24	- 7 - 28	- 18 - 31	- 14 - 35	18	30
+ 2 - 9	+ 3 - 13	+ 7 - 18	- 5 - 16	- 4 - 20	0 - 25	- 13 - 24	- 12 - 28	- 8 - 33	- 21 - 37	- 17 - 42	30	50
+ 3 - 10	+ 4 - 15	+ 9 - 21	- 6 - 19	- 5 - 24	0 - 30	- 15 - 28	- 14 - 33	- 9 - 39	- 26 - 45	- 21 - 51	50	80
+ 2 - 13	+ 4 - 18	+ 10 - 25	- 8 - 23	- 6 - 28	0 - 35	- 18 - 33	- 16 - 38	- 10 - 45	- 30 - 52	- 24 - 59	80	120
+ 3 - 15	+ 4 - 21	+ 12 - 28	- 9 - 27	- 8 - 33	0 - 40	- 21 - 39	- 20 - 45	- 12 - 52	- 36 - 61	- 28 - 68	120	180
+ 2 - 18	+ 5 - 24	+ 13 - 33	- 11 - 31	- 8 - 37	0 - 46	- 25 - 45	- 22 - 51	- 14 - 60	- 41 - 70	- 33 - 79	180	250
+ 3 - 20	+ 5 - 27	+ 16 - 36	- 13 - 36	- 9 - 41	0 - 52	- 27 - 50	- 25 - 57	- 14 - 66	- 47 - 79	- 36 - 88	250	315
+ 3 - 22	+ 7 - 29	+ 17 - 40	- 14 - 39	- 10 - 46	0 - 57	- 30 - 55	- 26 - 62	- 16 - 73	- 51 - 87	- 41 - 98	315	400
+ 2 - 25	+ 8 - 32	+ 18 - 45	- 16 - 43	- 10 - 50	0 - 63	- 33 - 60	- 27 - 67	- 17 - 80	- 55 - 95	- 45 - 108	400	500
—	0 - 44	0 - 70	—	- 26 - 70	- 26 - 96	—	- 44 - 88	- 44 - 114	- 78 - 122	- 78 - 148	500	630
—	0 - 50	0 - 80	—	- 30 - 80	- 30 - 110	—	- 50 - 100	- 50 - 130	- 88 - 138	- 88 - 168	630	800
—	0 - 56	0 - 90	—	- 34 - 90	- 34 - 124	—	- 56 - 112	- 56 - 146	- 100 - 156	- 100 - 190	800	1 000
—	0 - 66	0 - 105	—	- 40 - 106	- 40 - 145	—	- 66 - 132	- 66 - 171	- 120 - 186	- 120 - 225	1 000	1 250
—	0 - 78	0 - 125	—	- 48 - 126	- 48 - 173	—	- 78 - 156	- 78 - 203	- 140 - 218	- 140 - 265	1 250	1 600
—	0 - 92	0 - 150	—	- 58 - 150	- 58 - 208	—	- 92 - 184	- 92 - 242	- 170 - 262	- 170 - 320	1 600	2 000
—	0 - 110	0 - 175	—	- 68 - 178	- 68 - 243	—	- 110 - 220	- 110 - 285	- 195 - 305	- 195 - 370	2 000	2 500

Appendix Table 11 Values of

Basic Size (mm)		Standard										
		IT1	IT2	IT3	IT4	IT5	IT6	IT7	IT8	IT9	IT10	IT11
over	incl	Tolerances ( $\mu\text{m}$ )										
—	3	0.8	1.2	2	3	4	6	10	14	25	40	60
3	6	1	1.5	2.5	4	5	8	12	18	30	48	75
6	10	1	1.5	2.5	4	6	9	15	22	36	58	90
10	18	1.2	2	3	5	8	11	18	27	43	70	110
18	30	1.5	2.5	4	6	9	13	21	33	52	84	130
30	50	1.5	2.5	4	7	11	16	25	39	62	100	160
50	80	2	3	5	8	13	19	30	46	74	120	190
80	120	2.5	4	6	10	15	22	35	54	87	140	220
120	180	3.5	5	8	12	18	25	40	63	100	160	250
180	250	4.5	7	10	14	20	29	46	72	115	185	290
250	315	6	8	12	16	23	32	52	81	130	210	320
315	400	7	9	13	18	25	36	57	89	140	230	360
400	500	8	10	15	20	27	40	63	97	155	250	400
500	630	9	11	16	22	30	44	70	110	175	280	440
630	800	10	13	18	25	35	50	80	125	200	320	500
800	1 000	11	15	21	29	40	56	90	140	230	360	560
1 000	1 250	13	18	24	34	46	66	105	165	260	420	660
1 250	1 600	15	21	29	40	54	78	125	195	310	500	780
1 600	2 000	18	25	35	48	65	92	150	230	370	600	920
2 000	2 500	22	30	41	57	77	110	175	280	440	700	1 100
2 500	3 150	26	36	50	69	93	135	210	330	540	860	1 350

- Remarks**
- Standard tolerance grades IT14 to IT18 shall not be used for basic sizes less than or equal to 1mm.
  - Values for standard tolerance grades IT1 to IT5 for basic sizes over 500mm are included for experimental use.

Standard Tolerance Grades IT

Grades							Basic Size (mm)	
IT12	IT13	IT14	IT15	IT16	IT17	IT18	over	incl
Tolerances (mm)							over	incl
0.10	0.14	0.26	0.40	0.60	1.00	1.40	—	3
0.12	0.18	0.30	0.48	0.75	1.20	1.80	3	6
0.15	0.22	0.36	0.58	0.90	1.50	2.20	6	10
0.18	0.27	0.43	0.70	1.10	1.80	2.70	10	18
0.21	0.33	0.52	0.84	1.30	2.10	3.30	18	30
0.25	0.39	0.62	1.00	1.60	2.50	3.90	30	50
0.30	0.46	0.74	1.20	1.90	3.00	4.60	50	80
0.35	0.54	0.87	1.40	2.20	3.50	5.40	80	120
0.40	0.63	1.00	1.60	2.50	4.00	6.30	120	180
0.46	0.72	1.15	1.85	2.90	4.60	7.20	180	250
0.52	0.81	1.30	2.10	3.20	5.20	8.10	250	315
0.57	0.89	1.40	2.30	3.60	5.70	8.90	315	400
0.63	0.97	1.55	2.50	4.00	6.30	9.70	400	500
0.70	1.10	1.75	2.80	4.40	7.00	11.00	500	630
0.80	1.25	2.00	3.20	5.00	8.00	12.50	630	800
0.90	1.40	2.30	3.60	5.60	9.00	14.00	800	1 000
1.05	1.65	2.60	4.20	6.60	10.50	16.50	1 000	1 250
1.25	1.95	3.10	5.00	7.80	12.50	19.50	1 250	1 600
1.50	2.30	3.70	6.00	9.20	15.00	23.00	1 600	2 000
1.75	2.80	4.40	7.00	11.00	17.50	28.00	2 000	2 500
2.10	3.30	5.40	8.60	13.50	21.00	33.00	2 500	3 150

Appendix Table 12 Speed Factor  $f_n$

Speed $n$ (rpm)	Speed Factor $f_n$		Speed $n$ (rpm)	Speed Factor $f_n$	
	Ball Bearings	Roller Bearings		Ball Bearings	Roller Bearings
	10	1.49		1.44	180
11	1.45	1.39	190	0.560	0.593
12	1.41	1.36	200	0.550	0.584
13	1.37	1.33	220	0.533	0.568
14	1.34	1.30	240	0.518	0.553
15	1.30	1.27	260	0.504	0.540
16	1.28	1.25	280	0.492	0.528
17	1.25	1.22	300	0.481	0.517
18	1.23	1.20	320	0.471	0.507
19	1.21	1.18	340	0.461	0.498
20	1.19	1.17	360	0.452	0.490
21	1.17	1.15	380	0.444	0.482
22	1.15	1.13	400	0.437	0.475
23	1.13	1.12	420	0.430	0.468
24	1.12	1.10	440	0.423	0.461
25	1.10	1.09	460	0.417	0.455
26	1.09	1.08	480	0.411	0.449
27	1.07	1.07	500	0.405	0.444
28	1.06	1.05	550	0.393	0.431
29	1.05	1.04	600	0.382	0.420
30	1.04	1.03	650	0.372	0.410
31	1.02	1.02	700	0.362	0.401
32	1.01	1.01	750	0.354	0.393
<b>33.3</b>	<b>1.00</b>	<b>1.00</b>	800	0.347	0.385
34	0.993	0.994	850	0.340	0.378
36	0.975	0.977	900	0.333	0.372
38	0.957	0.961	950	0.327	0.366
40	0.941	0.947	1 000	0.322	0.360
42	0.926	0.933	1 050	0.317	0.355
44	0.912	0.920	1 100	0.312	0.350
46	0.898	0.908	1 150	0.307	0.346
48	0.886	0.896	1 200	0.303	0.341
50	0.874	0.885	1 250	0.299	0.337
55	0.846	0.861	1 300	0.295	0.333
60	0.822	0.838	1 400	0.288	0.326
65	0.800	0.818	1 500	0.281	0.319
70	0.781	0.800	1 600	0.275	0.313
75	0.763	0.784	1 700	0.270	0.307
80	0.747	0.769	1 800	0.265	0.302
85	0.732	0.755	1 900	0.260	0.297
90	0.718	0.742	2 000	0.255	0.293
95	0.705	0.730	2 100	0.251	0.289
100	0.693	0.719	2 200	0.247	0.285
110	0.672	0.699	2 300	0.244	0.281
120	0.652	0.681	2 400	0.240	0.277
130	0.635	0.665	2 500	0.237	0.274
140	0.620	0.650	2 600	0.234	0.271
150	0.606	0.637	2 700	0.231	0.268
160	0.593	0.625	2 800	0.228	0.265
170	0.581	0.613	2 900	0.226	0.262

Ball Bearings  $f_n = (0.03 n)^{-1/3}$   
 Roller Bearings  $f_n = (0.03 n)^{-3/10}$

Speed $n$ (rpm)	Speed Factor $f_n$		Speed $n$ (rpm)	Speed Factor $f_n$	
	Ball Bearings	Roller Bearings		Ball Bearings	Roller Bearings
	3 000	0.223		0.259	4 000
3 200	0.218	0.254	4 200	0.199	0.234
3 400	0.214	0.250	4 400	0.196	0.231
3 600	0.210	0.245	4 600	0.194	0.228
3 800	0.206	0.242	4 800	0.191	0.225
5 000	0.188	0.222	5 200	0.186	0.220
5 400	0.183	0.217	5 600	0.181	0.215
5 800	0.179	0.213	6 000	0.177	0.211
6 200	0.175	0.209	6 400	0.173	0.207
6 600	0.172	0.205	6 800	0.170	0.203
7 000	0.168	0.201	7 200	0.167	0.199
7 400	0.165	0.198	7 600	0.164	0.196
7 800	0.162	0.195	8 000	0.161	0.193
8 500	0.158	0.190	9 000	0.155	0.186
9 500	0.152	0.183	10 000	0.149	0.181
11 000	0.145	0.176	12 000	0.141	0.171
13 000	0.137	0.167	14 000	0.134	0.163
15 000	0.130	0.160	16 000	0.128	0.157
17 000	0.125	0.154	18 000	0.123	0.151
19 000	0.121	0.149	20 000	0.119	0.147
22 000	0.115	0.143	24 000	0.112	0.139
26 000	0.109	0.136	28 000	0.106	0.133
30 000	0.104	0.130	32 000	0.101	0.127
34 000	0.099	0.125	36 000	0.097	0.123
38 000	0.096	0.121	40 000	0.094	0.119

Appendix Table 13 Fatigue Life Factor  $f_n$  and Fatigue Life  $L \cdot L_h$

Ball Bearings  $L = (C / P)^3 L_h = 500 f_n^3$   
 Roller Bearings  $L = (C / P)^{10/3} L_h = 500 f_n^{10/3}$

$C/P$ or $f_h$	Ball Bearing Life		Roller Bearing Life		$C/P$ or $f_h$	Ball Bearing Life		Roller Bearing Life	
	$L$	$L_h$	$L$	$L_h$		$L$	$L_h$	$L$	$L_h$
	( $10^6$ rev)	(h)	( $10^6$ rev)	(h)		( $10^6$ rev)	(h)	( $10^6$ rev)	(h)
0.70	0.34	172	0.30	152	3.45	41.1	20 500	62.0	31 000
0.75	0.42	211	0.38	192	3.50	42.9	21 400	65.1	32 500
0.80	0.51	256	0.48	238	3.55	44.7	22 400	68.2	34 100
0.85	0.61	307	0.58	291	3.60	46.7	23 300	71.5	35 800
0.90	0.73	365	0.70	352	3.65	48.6	24 300	74.9	37 400
0.95	0.86	429	0.84	421	3.70	50.7	25 300	78.3	39 200
<b>1.00</b>	<b>1.00</b>	<b>500</b>	<b>1.00</b>	<b>500</b>	3.75	52.7	26 400	81.9	41 000
1.05	1.16	579	1.18	588	3.80	54.9	27 400	85.6	42 800
1.10	1.33	665	1.37	687	3.85	57.1	28 500	89.4	44 700
1.15	1.52	760	1.59	797	3.90	59.3	29 700	93.4	46 700
1.20	1.73	864	1.84	918	3.95	61.6	30 800	97.4	48 700
1.25	1.95	977	2.10	1 050	4.00	64.0	32 000	102	50 800
1.30	2.20	1 100	2.40	1 200	4.05	66.4	33 200	106	52 900
1.35	2.46	1 230	2.72	1 360	4.10	68.9	34 500	110	55 200
1.40	2.74	1 370	3.07	1 530	4.15	71.5	35 700	115	57 400
1.45	3.05	1 520	3.45	1 730	4.20	74.1	37 000	120	59 800
1.50	3.38	1 690	3.86	1 930	4.25	76.8	38 400	124	62 200
1.55	3.72	1 860	4.31	2 150	4.30	79.5	39 800	129	64 600
1.60	4.10	2 050	4.79	2 400	4.35	82.3	41 200	134	67 200
1.65	4.49	2 250	5.31	2 650	4.40	85.2	42 600	140	69 800
1.70	4.91	2 460	5.86	2 930	4.45	88.1	44 100	145	72 500
1.75	5.36	2 680	6.46	3 230	4.50	91.1	45 600	150	75 200
1.80	5.83	2 920	7.09	3 550	4.55	94.2	47 100	156	78 000
1.85	6.33	3 170	7.77	3 890	4.60	97.3	48 700	162	80 900
1.90	6.86	3 430	8.50	4 250	4.65	101	50 300	168	83 900
1.95	7.41	3 710	9.26	4 630	4.70	104	51 900	174	87 000
2.00	8.00	4 000	10.1	5 040	4.75	107	53 600	180	90 100
2.05	8.62	4 310	10.9	5 470	4.80	111	55 300	187	93 300
2.10	9.26	4 630	11.9	5 930	4.85	114	57 000	193	96 600
2.15	9.94	4 970	12.8	6 410	4.90	118	58 800	200	99 900
2.20	10.6	5 320	13.8	6 920	4.95	121	60 600	207	103 000
2.25	11.4	5 700	14.9	7 460	5.00	125	62 500	214	107 000
2.30	12.2	6 080	16.1	8 030	5.10	133	66 300	228	114 000
2.35	13.0	6 490	17.3	8 630	5.20	141	70 300	244	122 000
2.40	13.8	6 910	18.5	9 250	5.30	149	74 400	260	130 000
2.45	14.7	7 350	19.8	9 910	5.40	157	78 700	276	138 000
2.50	15.6	7 810	21.2	10 600	5.50	166	83 200	294	147 000
2.55	16.6	8 290	22.7	11 300	5.60	176	87 800	312	156 000
2.60	17.6	8 790	24.2	12 100	5.70	185	92 600	331	165 000
2.65	18.6	9 300	25.8	12 900	5.80	195	97 600	351	175 000
2.70	19.7	9 840	27.4	13 700	5.90	205	103 000	371	186 000
2.75	20.8	10 400	29.1	14 600	6.00	216	108 000	392	196 000
2.80	22.0	11 000	30.9	15 500	6.50	275	137 000	513	256 000
2.85	23.1	11 600	32.8	16 400	7.00	343	172 000	656	328 000
2.90	24.4	12 200	34.8	17 400	7.50	422	211 000	826	413 000
2.95	25.7	12 800	36.8	18 400	8.00	512	256 000	1 020	512 000
3.00	27.0	13 500	38.9	19 500	8.50	614	307 000	1 250	627 000
3.05	28.4	14 200	41.1	20 600	9.00	729	365 000	1 520	758 000
3.10	29.8	14 900	43.4	21 700	9.50	857	429 000	1 820	908 000
3.15	31.3	15 600	45.8	22 900	10.0	1 000	—	2 150	—
3.20	32.8	16 400	48.3	24 100	11.0	1 330	—	2 960	—
3.25	34.3	17 200	50.8	25 400	12.0	1 730	—	3 960	—
3.30	35.9	18 000	53.5	26 800	13.0	2 200	—	5 170	—
3.35	37.6	18 800	56.3	28 100	14.0	2 740	—	6 610	—
3.40	39.3	19 700	59.1	29 600	15.0	3 380	—	8 320	—

Appendix Table14 Index of Inch Design Tapered Roller Bearings

Bearing No. CONE, CUP	Nominal Dimension (mm) d: CONE (Bore Dia.) D: CUP (Outside Dia.)	Pages	Bearing No. CONE, CUP	Nominal Dimension (mm) d: CONE (Bore Dia.) D: CUP (Outside Dia.)	Pages
<b>332</b>	<i>D</i> 80.000	B136, B140, B142	<b>497</b>	<i>d</i> 85.725	B158
<b>336</b>	<i>d</i> 41.275	B142	<b>498</b>	<i>d</i> 84.138	B158
<b>342</b>	<i>d</i> 41.275	B142	<b>522</b>	<i>D</i> 101.600	B144, B146
<b>342 S</b>	<i>d</i> 42.875	B142	<b>528</b>	<i>d</i> 47.625	B144
<b>344</b>	<i>d</i> 40.000	B140	<b>529</b>	<i>d</i> 50.800	B146
<b>344 A</b>	<i>d</i> 40.000	B140	<b>529 X</b>	<i>d</i> 50.800	B146
<b>346</b>	<i>d</i> 31.750	B136	<b>532 X</b>	<i>D</i> 107.950	B148
<b>354 A</b>	<i>D</i> 85.000	B144	<b>539</b>	<i>d</i> 53.975	B148
<b>359 S</b>	<i>d</i> 46.038	B144	<b>552 A</b>	<i>D</i> 123.825	B148, B150, B152
<b>362 A</b>	<i>D</i> 88.900	B144, B146	<b>553 X</b>	<i>D</i> 122.238	B150, B152
<b>366</b>	<i>d</i> 50.000	B146	<b>555 S</b>	<i>d</i> 57.150	B148
<b>368</b>	<i>d</i> 50.800	B146	<b>557 S</b>	<i>d</i> 53.975	B148
<b>368 A</b>	<i>d</i> 50.800	B146	<b>558</b>	<i>d</i> 60.325	B150
<b>369 A</b>	<i>d</i> 47.625	B144	<b>559</b>	<i>d</i> 63.500	B150
<b>372</b>	<i>D</i> 100.000	B146	<b>560</b>	<i>d</i> 66.675	B152
<b>374</b>	<i>D</i> 93.264	B144	<b>560 S</b>	<i>d</i> 68.262	B152
<b>376</b>	<i>d</i> 45.000	B144	<b>563</b>	<i>D</i> 127.000	B150, B152, B154
<b>377</b>	<i>d</i> 52.388	B146	<b>563 X</b>	<i>D</i> 127.000	B152
<b>382</b>	<i>D</i> 98.425	B148	<b>565</b>	<i>d</i> 63.500	B150
<b>382 A</b>	<i>D</i> 96.838	B148	<b>566</b>	<i>d</i> 69.850	B152
<b>382 S</b>	<i>D</i> 96.838	B148	<b>567</b>	<i>d</i> 73.025	B154
<b>385</b>	<i>d</i> 55.000	B148	<b>567 A</b>	<i>d</i> 71.438	B154
<b>387</b>	<i>d</i> 57.150	B148	<b>567 S</b>	<i>d</i> 71.438	B154
<b>387 A</b>	<i>d</i> 57.150	B148	<b>568</b>	<i>d</i> 73.817	B154
<b>388 A</b>	<i>d</i> 57.531	B148	<b>569</b>	<i>d</i> 64.963	B150
<b>390 A</b>	<i>d</i> 63.500	B150	<b>570</b>	<i>d</i> 68.262	B152
<b>394 A</b>	<i>D</i> 110.000	B150, B152	<b>572</b>	<i>D</i> 139.992	B154, B156
<b>395</b>	<i>d</i> 63.500	B150	<b>572 X</b>	<i>D</i> 139.700	B156
<b>395 A</b>	<i>d</i> 66.675	B152	<b>575</b>	<i>d</i> 76.200	B154
<b>395 S</b>	<i>d</i> 66.675	B152	<b>580</b>	<i>d</i> 82.550	B156
<b>397</b>	<i>d</i> 60.000	B150	<b>581</b>	<i>d</i> 80.962	B156
<b>399 A</b>	<i>d</i> 68.262	B152	<b>582</b>	<i>d</i> 82.550	B156
<b>414</b>	<i>D</i> 88.501	B140	<b>590 A</b>	<i>d</i> 76.200	B154
<b>418</b>	<i>d</i> 38.100	B140	<b>592</b>	<i>D</i> 152.400	B160
<b>432</b>	<i>D</i> 95.250	B142	<b>592 A</b>	<i>D</i> 152.400	B154, B158, B160
<b>432 A</b>	<i>D</i> 95.250	B144	<b>593</b>	<i>d</i> 88.900	B158
<b>436</b>	<i>d</i> 46.038	B144	<b>594</b>	<i>d</i> 95.250	B160
<b>438</b>	<i>d</i> 44.450	B142	<b>596</b>	<i>d</i> 85.725	B158
<b>453 A</b>	<i>D</i> 107.950	B144	<b>597</b>	<i>d</i> 93.662	B160
<b>453 X</b>	<i>D</i> 104.775	B148	<b>598</b>	<i>d</i> 92.075	B160
<b>460</b>	<i>d</i> 44.450	B144	<b>598 A</b>	<i>d</i> 92.075	B160
<b>462</b>	<i>d</i> 57.150	B148	<b>614 X</b>	<i>D</i> 115.000	B148
<b>469</b>	<i>d</i> 57.150	B148	<b>622 X</b>	<i>d</i> 55.000	B148
<b>472</b>	<i>D</i> 120.000	B152, B154	<b>632</b>	<i>D</i> 136.525	B150, B154
<b>472 A</b>	<i>D</i> 120.000	B152	<b>633</b>	<i>D</i> 130.175	B150, B152, B154
<b>478</b>	<i>d</i> 65.000	B152	<b>637</b>	<i>d</i> 60.325	B150
<b>480</b>	<i>d</i> 68.262	B152	<b>639</b>	<i>d</i> 63.500	B150
<b>484</b>	<i>d</i> 70.000	B154	<b>643</b>	<i>d</i> 69.850	B152
<b>492 A</b>	<i>D</i> 133.350	B156, B158	<b>644</b>	<i>d</i> 71.438	B154
<b>493</b>	<i>D</i> 136.525	B154, B156, B158	<b>645</b>	<i>d</i> 71.438	B154
<b>495</b>	<i>d</i> 82.550	B156	<b>652</b>	<i>D</i> 152.400	B154, B156
<b>495 A</b>	<i>d</i> 76.200	B154	<b>653</b>	<i>D</i> 146.050	B152, B154, B156, B158
<b>495 AX</b>	<i>d</i> 76.200	B154	<b>653 X</b>	<i>D</i> 150.000	B154
<b>496</b>	<i>d</i> 80.962	B156	<b>655</b>	<i>d</i> 69.850	B152

Bearing No. CONE, CUP	Nominal Dimension (mm) d: CONE (Bore Dia.) D: CUP (Outside Dia.)	Pages	Bearing No. CONE, CUP	Nominal Dimension (mm) d: CONE (Bore Dia.) D: CUP (Outside Dia.)	Pages
<b>657</b>	<i>d</i> 73.025	B154	<b>1328</b>	<i>D</i> 52.388	B132
<b>658</b>	<i>d</i> 74.612	B154	<b>1329</b>	<i>D</i> 53.975	B132
<b>659</b>	<i>d</i> 76.200	B154	<b>1380</b>	<i>d</i> 22.225	B132
<b>661</b>	<i>d</i> 79.375	B156	<b>1620</b>	<i>D</i> 66.675	B138
<b>663</b>	<i>d</i> 82.550	B156	<b>1680</b>	<i>d</i> 33.338	B138
<b>664</b>	<i>d</i> 84.138	B158	<b>1729</b>	<i>D</i> 56.896	B132, B134
<b>665</b>	<i>d</i> 85.725	B158	<b>1755</b>	<i>d</i> 22.225	B132
<b>665 A</b>	<i>d</i> 85.725	B158	<b>1779</b>	<i>d</i> 23.812	B134
<b>672</b>	<i>D</i> 168.275	B158, B160, B162	<b>1922</b>	<i>D</i> 57.150	B134
<b>677</b>	<i>d</i> 85.725	B158	<b>1988</b>	<i>d</i> 28.575	B134
<b>681</b>	<i>d</i> 92.075	B160	<b>1997 X</b>	<i>d</i> 26.988	B134
<b>683</b>	<i>d</i> 95.250	B160	<b>A2047</b>	<i>d</i> 12.000	B132
<b>685</b>	<i>d</i> 98.425	B160	<b>A2126</b>	<i>D</i> 31.991	B132
<b>687</b>	<i>d</i> 101.600	B162	<b>2523</b>	<i>D</i> 69.850	B136, B138
<b>742</b>	<i>D</i> 150.089	B152, B156, B158	<b>2558</b>	<i>d</i> 30.162	B136
<b>743</b>	<i>D</i> 150.000	B156	<b>2559</b>	<i>d</i> 30.162	B136
<b>745 A</b>	<i>d</i> 69.850	B152	<b>2580</b>	<i>d</i> 31.750	B136
<b>749</b>	<i>d</i> 85.026	B158	<b>2582</b>	<i>d</i> 31.750	B136
<b>749 A</b>	<i>d</i> 82.550	B156	<b>2585</b>	<i>d</i> 33.338	B138
<b>749 S</b>	<i>d</i> 85.026	B158	<b>2631</b>	<i>D</i> 66.421	B136
<b>750</b>	<i>d</i> 79.375	B156	<b>2690</b>	<i>d</i> 29.367	B136
<b>752</b>	<i>D</i> 161.925	B156, B158	<b>2720</b>	<i>D</i> 76.200	B140
<b>753</b>	<i>D</i> 168.275	B156, B158	<b>2729</b>	<i>D</i> 76.200	B140
<b>757</b>	<i>d</i> 82.550	B156	<b>2735 X</b>	<i>D</i> 73.025	B140
<b>758</b>	<i>d</i> 85.725	B158	<b>2788</b>	<i>d</i> 38.100	B140
<b>759</b>	<i>d</i> 88.900	B158	<b>2789</b>	<i>d</i> 39.688	B140
<b>760</b>	<i>d</i> 90.488	B158	<b>2820</b>	<i>D</i> 73.025	B138
<b>766</b>	<i>d</i> 88.900	B158	<b>2877</b>	<i>d</i> 34.925	B138
<b>772</b>	<i>D</i> 180.975	B160, B162	<b>2924</b>	<i>D</i> 85.000	B144
<b>776</b>	<i>d</i> 95.250	B160	<b>2984</b>	<i>d</i> 46.038	B144
<b>779</b>	<i>d</i> 98.425	B160	<b>3120</b>	<i>D</i> 72.626	B136, B138
<b>780</b>	<i>d</i> 101.600	B162	<b>3188</b>	<i>d</i> 31.750	B136
<b>782</b>	<i>d</i> 104.775	B162	<b>3197</b>	<i>d</i> 33.338	B138
<b>787</b>	<i>d</i> 104.775	B162	<b>3320</b>	<i>D</i> 80.167	B140
<b>792</b>	<i>D</i> 206.375	B164	<b>3386</b>	<i>d</i> 39.688	B140
<b>795</b>	<i>d</i> 120.650	B164	<b>3420</b>	<i>D</i> 79.375	B138, B140
<b>797</b>	<i>d</i> 130.000	B164	<b>3478</b>	<i>d</i> 34.925	B138
<b>799</b>	<i>d</i> 128.588	B164	<b>3479</b>	<i>d</i> 36.512	B140
<b>799 A</b>	<i>d</i> 130.175	B164	<b>3490</b>	<i>d</i> 38.100	B140
<b>832</b>	<i>D</i> 168.275	B156, B158	<b>3525</b>	<i>D</i> 87.312	B142
<b>837</b>	<i>d</i> 76.200	B156	<b>3576</b>	<i>d</i> 41.275	B142
<b>842</b>	<i>d</i> 82.550	B156	<b>3578</b>	<i>d</i> 44.450	B142
<b>843</b>	<i>d</i> 76.200	B156	<b>3720</b>	<i>D</i> 93.264	B142
<b>850</b>	<i>d</i> 88.900	B158	<b>3730</b>	<i>D</i> 93.264	B146
<b>854</b>	<i>D</i> 190.500	B158, B160, B162	<b>3775</b>	<i>d</i> 50.800	B146
<b>855</b>	<i>d</i> 88.900	B158	<b>3780</b>	<i>d</i> 50.800	B146
<b>861</b>	<i>d</i> 101.600	B162	<b>3782</b>	<i>d</i> 44.450	B142
<b>864</b>	<i>d</i> 95.250	B160	<b>3820</b>	<i>D</i> 85.725	B142
<b>866</b>	<i>d</i> 98.425	B160	<b>3877</b>	<i>d</i> 41.275	B142
<b>932</b>	<i>D</i> 212.725	B162	<b>3920</b>	<i>D</i> 112.712	B150, B152
<b>938</b>	<i>d</i> 114.300	B162	<b>3926</b>	<i>D</i> 112.712	B148, B150
<b>1220</b>	<i>D</i> 57.150	B132	<b>3981</b>	<i>d</i> 58.738	B148
<b>1280</b>	<i>d</i> 22.225	B132	<b>3982</b>	<i>d</i> 63.500	B150
			<b>3984</b>	<i>d</i> 66.675	B152

Bearing No. CONE, CUP	Nominal Dimension (mm) <i>d</i> :CONE (Bore Dia.) <i>D</i> :CUP (Outside Dia.)	Pages
<b>3994</b>	<i>d</i> 66.675	B152
<b>A4050</b>	<i>d</i> 12.700	B132
<b>A4059</b>	<i>d</i> 15.000	B132
<b>A4138</b>	<i>D</i> 34.988	B132
<b>4335</b>	<i>D</i> 90.488	B142
<b>4388</b>	<i>D</i> 41.275	B142
<b>4535</b>	<i>D</i> 104.775	B148
<b>4595</b>	<i>d</i> 53.975	B148
<b>A5069</b>	<i>d</i> 17.455	B132
<b>A5144</b>	<i>D</i> 36.525	B132
<b>5335</b>	<i>D</i> 103.188	B144
<b>5356</b>	<i>d</i> 44.450	B144
<b>5535</b>	<i>D</i> 122.238	B148, B150
<b>5566</b>	<i>d</i> 55.562	B148
<b>5582</b>	<i>d</i> 60.325	B150
<b>5584</b>	<i>d</i> 63.500	B150
<b>5735</b>	<i>D</i> 135.732	B154, B156
<b>5760</b>	<i>d</i> 76.200	B154
<b>5795</b>	<i>d</i> 77.788	B156
<b>A6062</b>	<i>d</i> 15.875	B132
<b>A6067</b>	<i>d</i> 16.993	B132
<b>A6075</b>	<i>d</i> 19.050	B132
<b>A6157</b>	<i>D</i> 39.992	B132
<b>6220</b>	<i>D</i> 127.000	B146, B148
<b>6279</b>	<i>d</i> 50.800	B146
<b>6280</b>	<i>d</i> 53.975	B148
<b>6320</b>	<i>D</i> 135.755	B150, B152
<b>6376</b>	<i>d</i> 60.325	B150
<b>6379</b>	<i>d</i> 65.088	B152
<b>6420</b>	<i>D</i> 149.225	B148, B152, B154
<b>6454</b>	<i>d</i> 69.850	B152
<b>6455</b>	<i>d</i> 57.150	B148
<b>6460</b>	<i>d</i> 73.025	B154
<b>6461</b>	<i>d</i> 76.200	B154
<b>6535</b>	<i>D</i> 161.925	B154, B156, B158
<b>6536</b>	<i>D</i> 161.925	B154
<b>6559</b>	<i>d</i> 82.550	B156
<b>6575</b>	<i>d</i> 76.200	B154
<b>6576</b>	<i>d</i> 76.200	B154
<b>6580</b>	<i>d</i> 88.900	B158
<b>9121</b>	<i>D</i> 152.400	B150, B152
<b>9180</b>	<i>d</i> 61.912	B150
<b>9185</b>	<i>d</i> 68.262	B152
<b>9220</b>	<i>D</i> 161.925	B154
<b>9285</b>	<i>d</i> 76.200	B154
<b>9320</b>	<i>D</i> 177.800	B156
<b>9321</b>	<i>D</i> 171.450	B156, B158
<b>9378</b>	<i>d</i> 76.200	B156
<b>9380</b>	<i>d</i> 76.200	B156
<b>9385</b>	<i>d</i> 84.138	B158
<b>02420</b>	<i>D</i> 68.262	B134, B136
<b>02473</b>	<i>d</i> 25.400	B134
<b>02474</b>	<i>d</i> 28.575	B134
<b>02475</b>	<i>d</i> 31.750	B136

Bearing No. CONE, CUP	Nominal Dimension (mm) <i>d</i> :CONE (Bore Dia.) <i>D</i> :CUP (Outside Dia.)	Pages
<b>02820</b>	<i>D</i> 73.025	B134, B138
<b>02872</b>	<i>d</i> 28.575	B134
<b>02878</b>	<i>d</i> 34.925	B138
<b>03062</b>	<i>d</i> 15.875	B132
<b>03162</b>	<i>D</i> 41.275	B132
<b>05062</b>	<i>d</i> 15.875	B132
<b>05068</b>	<i>d</i> 17.462	B132
<b>05075</b>	<i>d</i> 19.050	B132
<b>05079</b>	<i>d</i> 19.990	B132
<b>05175</b>	<i>D</i> 44.450	B132
<b>05185</b>	<i>D</i> 47.000	B132
<b>07079</b>	<i>d</i> 20.000	B132
<b>07087</b>	<i>d</i> 22.225	B132
<b>07097</b>	<i>d</i> 25.000	B134
<b>07098</b>	<i>d</i> 24.981	B134
<b>07100</b>	<i>d</i> 25.400	B134
<b>07100SA</b>	<i>d</i> 25.400	B134
<b>07196</b>	<i>D</i> 50.005	B132, B134
<b>07204</b>	<i>D</i> 51.994	B132, B134
<b>07205</b>	<i>D</i> 52.001	B134
<b>08118</b>	<i>d</i> 30.162	B136
<b>08125</b>	<i>d</i> 31.750	B136
<b>08231</b>	<i>D</i> 58.738	B136
<b>09062</b>	<i>d</i> 15.875	B132
<b>09067</b>	<i>d</i> 19.050	B132
<b>09074</b>	<i>d</i> 19.050	B132
<b>09078</b>	<i>d</i> 19.050	B132
<b>09081</b>	<i>d</i> 20.625	B132
<b>09194</b>	<i>D</i> 49.225	B132
<b>09195</b>	<i>D</i> 49.225	B132
<b>09196</b>	<i>D</i> 49.225	B132
<b>11162</b>	<i>d</i> 41.275	B142
<b>11300</b>	<i>D</i> 76.200	B142
<b>11520</b>	<i>D</i> 42.862	B132
<b>11590</b>	<i>d</i> 15.875	B132
<b>LM11710</b>	<i>d</i> 39.878	B132
<b>LM11749</b>	<i>d</i> 17.462	B132
<b>LM11910</b>	<i>D</i> 45.237	B132
<b>LM11949</b>	<i>d</i> 19.050	B132
<b>12168</b>	<i>d</i> 42.862	B142
<b>12303</b>	<i>D</i> 76.992	B142
<b>12520</b>	<i>D</i> 49.225	B132
<b>12580</b>	<i>d</i> 20.638	B132
<b>M12610</b>	<i>d</i> 50.005	B132
<b>M12648</b>	<i>d</i> 22.225	B132
<b>M12649</b>	<i>d</i> 21.430	B132
<b>LM12710</b>	<i>D</i> 45.237	B132
<b>LM12711</b>	<i>D</i> 45.975	B132
<b>LM12749</b>	<i>d</i> 22.000	B132
<b>13175</b>	<i>d</i> 44.450	B142
<b>13181</b>	<i>d</i> 46.038	B144
<b>13318</b>	<i>D</i> 80.962	B142, B144
<b>13620</b>	<i>D</i> 69.012	B140
<b>13621</b>	<i>D</i> 69.012	B140

Bearing No. CONE, CUP	Nominal Dimension (mm) <i>d</i> :CONE (Bore Dia.) <i>D</i> :CUP (Outside Dia.)	Pages
<b>13685</b>	<i>d</i> 38.100	B140
<b>13687</b>	<i>d</i> 38.100	B140
<b>13830</b>	<i>D</i> 63.500	B140
<b>13889</b>	<i>d</i> 38.100	B140
<b>14123 A</b>	<i>d</i> 31.750	B136
<b>14125 A</b>	<i>d</i> 31.750	B136
<b>14130</b>	<i>d</i> 33.338	B138
<b>14131</b>	<i>d</i> 33.338	B138
<b>14137 A</b>	<i>d</i> 34.925	B138
<b>14138 A</b>	<i>d</i> 34.925	B138
<b>14139</b>	<i>d</i> 34.976	B138
<b>14274</b>	<i>D</i> 69.012	B136, B138
<b>14276</b>	<i>D</i> 69.012	B136, B138
<b>14283</b>	<i>D</i> 72.085	B138
<b>15100</b>	<i>d</i> 25.400	B134
<b>15101</b>	<i>d</i> 25.400	B134
<b>15106</b>	<i>d</i> 26.988	B134
<b>15112</b>	<i>d</i> 28.575	B134
<b>15113</b>	<i>d</i> 28.575	B134
<b>15116</b>	<i>d</i> 30.112	B136
<b>15117</b>	<i>d</i> 30.000	B136
<b>15118</b>	<i>d</i> 30.213	B136
<b>15119</b>	<i>d</i> 30.213	B136
<b>15120</b>	<i>d</i> 30.213	B136
<b>15123</b>	<i>d</i> 31.750	B136
<b>15125</b>	<i>d</i> 31.750	B136
<b>15126</b>	<i>d</i> 31.750	B136
<b>15245</b>	<i>D</i> 62.000	B134, B136
<b>15250</b>	<i>D</i> 63.500	B136
<b>15250 X</b>	<i>D</i> 63.500	B134
<b>15520</b>	<i>D</i> 57.150	B134
<b>15523</b>	<i>D</i> 60.325	B134
<b>15578</b>	<i>d</i> 25.400	B134
<b>15580</b>	<i>d</i> 26.988	B134
<b>16150</b>	<i>d</i> 38.100	B140
<b>16284</b>	<i>D</i> 72.238	B140
<b>16929</b>	<i>D</i> 74.988	B142
<b>16986</b>	<i>d</i> 43.000	B142
<b>17098</b>	<i>d</i> 24.981	B134
<b>17118</b>	<i>d</i> 30.000	B136
<b>17244</b>	<i>D</i> 62.000	B134, B136
<b>17520</b>	<i>D</i> 42.862	B132
<b>17580</b>	<i>d</i> 15.875	B132
<b>17831</b>	<i>D</i> 79.985	B144
<b>17887</b>	<i>d</i> 45.230	B144
<b>18200</b>	<i>d</i> 50.800	B146
<b>18337</b>	<i>D</i> 85.725	B146
<b>18520</b>	<i>D</i> 73.025	B140
<b>18590</b>	<i>d</i> 41.275	B140
<b>18620</b>	<i>D</i> 79.375	B144
<b>18690</b>	<i>d</i> 46.038	B144
<b>18720</b>	<i>D</i> 85.000	B146
<b>18790</b>	<i>d</i> 50.800	B146
<b>19138</b>	<i>d</i> 34.976	B138

Bearing No. CONE, CUP	Nominal Dimension (mm) <i>d</i> :CONE (Bore Dia.) <i>D</i> :CUP (Outside Dia.)	Pages
<b>19150</b>	<i>d</i> 38.100	B140
<b>19268</b>	<i>d</i> 68.262	B138, B140
<b>21075</b>	<i>d</i> 19.050	B132
<b>21212</b>	<i>D</i> 53.975	B132
<b>L21511</b>	<i>D</i> 34.988	B132
<b>L21549</b>	<i>d</i> 15.875	B132
<b>22168</b>	<i>d</i> 42.862	B142
<b>22325</b>	<i>D</i> 82.550	B142
<b>23100</b>	<i>d</i> 25.400	B134
<b>23256</b>	<i>D</i> 65.088	B134
<b>23621</b>	<i>D</i> 73.025	B138
<b>23691</b>	<i>d</i> 35.000	B138
<b>24720</b>	<i>D</i> 76.200	B142
<b>24721</b>	<i>D</i> 76.200	B142
<b>24780</b>	<i>d</i> 41.275	B142
<b>25520</b>	<i>D</i> 82.931	B142, B144
<b>25521</b>	<i>D</i> 83.058	B142
<b>25523</b>	<i>D</i> 82.931	B142, B144
<b>25577</b>	<i>d</i> 42.875	B142
<b>25578</b>	<i>d</i> 42.862	B142
<b>25580</b>	<i>d</i> 44.450	B142
<b>25584</b>	<i>d</i> 44.983	B144
<b>25590</b>	<i>d</i> 45.618	B144
<b>25820</b>	<i>D</i> 73.025	B138
<b>25821</b>	<i>D</i> 73.025	B138, B140
<b>25877</b>	<i>d</i> 34.925	B138
<b>25878</b>	<i>d</i> 34.925	B138
<b>25880</b>	<i>d</i> 36.487	B140
<b>26118</b>	<i>d</i> 30.000	B136
<b>26131</b>	<i>d</i> 33.338	B138
<b>26283</b>	<i>D</i> 72.000	B136, B138
<b>26820</b>	<i>D</i> 80.167	B142
<b>26822</b>	<i>D</i> 79.375	B142
<b>26823</b>	<i>D</i> 76.200	B142
<b>26882</b>	<i>d</i> 41.275	B142
<b>26884</b>	<i>d</i> 42.875	B142
<b>27620</b>	<i>D</i> 125.412	B156
<b>27687</b>	<i>d</i> 82.550	B156
<b>27689</b>	<i>d</i> 83.345	B156
<b>27690</b>	<i>d</i> 83.345	B156
<b>27820</b>	<i>D</i> 80.035	B140
<b>27880</b>	<i>d</i> 38.100	B140
<b>28138</b>	<i>d</i> 34.976	B138
<b>28315</b>	<i>D</i> 80.000	B138
<b>28521</b>	<i>D</i> 92.075	B146
<b>28580</b>	<i>d</i> 50.800	B146
<b>28584</b>	<i>d</i> 52.388	B146
<b>28622</b>	<i>D</i> 97.630	B148
<b>28680</b>	<i>d</i> 55.562	B148
<b>28920</b>	<i>D</i> 101.600	B150
<b>28921</b>	<i>D</i> 100.000	B150
<b>28985</b>	<i>d</i> 60.325	B150
<b>29520</b>	<i>D</i> 107.950	B150
<b>29586</b>	<i>D</i> 63.500	B150



Bearing No. CONE, CUP	Nominal Dimension (mm) <i>d</i> :CONE (Bore Dia.) <i>D</i> :CUP (Outside Dia.)	Pages
<b>29620</b>	<i>D</i> 112.712	B152, B154
<b>29630</b>	<i>D</i> 120.650	B152
<b>29675</b>	<i>d</i> 69.850	B152
<b>29685</b>	<i>d</i> 73.025	B154
<b>LM29710</b>	<i>D</i> 65.088	B140
<b>LM29711</b>	<i>D</i> 65.088	B140
<b>LM29748</b>	<i>d</i> 38.100	B140
<b>LM29749</b>	<i>D</i> 38.100	B140
<b>31520</b>	<i>D</i> 76.200	B138
<b>31594</b>	<i>d</i> 34.925	B138
<b>33262</b>	<i>d</i> 66.675	B152
<b>33275</b>	<i>d</i> 69.850	B152
<b>33281</b>	<i>d</i> 71.438	B154
<b>33287</b>	<i>d</i> 73.025	B154
<b>JHM33410</b>	<i>D</i> 55.000	B134
<b>JHM33449</b>	<i>d</i> 24.000	B134
<b>33462</b>	<i>D</i> 117.475	B152, B154
<b>33821</b>	<i>D</i> 95.250	B146
<b>33889</b>	<i>d</i> 50.800	B146
<b>34300</b>	<i>d</i> 76.200	B154
<b>34306</b>	<i>d</i> 77.788	B156
<b>34478</b>	<i>D</i> 121.442	B154, B156
<b>36620</b>	<i>D</i> 193.675	B164
<b>36690</b>	<i>d</i> 146.050	B164
<b>36920</b>	<i>D</i> 227.012	B166
<b>36990</b>	<i>d</i> 177.800	B166
<b>37425</b>	<i>d</i> 107.950	B162
<b>37625</b>	<i>D</i> 158.750	B162
<b>M38510</b>	<i>D</i> 66.675	B138
<b>M38511</b>	<i>D</i> 65.987	B138
<b>M38547</b>	<i>d</i> 35.000	B138
<b>M38549</b>	<i>d</i> 34.925	B138
<b>39236</b>	<i>d</i> 60.000	B150
<b>39250</b>	<i>d</i> 63.500	B150
<b>39412</b>	<i>D</i> 104.775	B150
<b>39520</b>	<i>D</i> 112.712	B150, B152
<b>39521</b>	<i>D</i> 112.712	B152
<b>39585</b>	<i>d</i> 63.500	B150
<b>39590</b>	<i>d</i> 66.675	B152
<b>41100</b>	<i>d</i> 25.400	B134
<b>41125</b>	<i>d</i> 28.575	B134
<b>41126</b>	<i>d</i> 28.575	B134
<b>41286</b>	<i>D</i> 72.626	B134
<b>42350</b>	<i>d</i> 88.900	B158
<b>42362</b>	<i>d</i> 92.075	B160
<b>42368</b>	<i>d</i> 93.662	B160
<b>42375</b>	<i>d</i> 95.250	B160
<b>42376</b>	<i>d</i> 95.250	B160
<b>42381</b>	<i>D</i> 96.838	B160
<b>42584</b>	<i>D</i> 148.430	B160
<b>42587</b>	<i>D</i> 149.225	B158, B160
<b>42620</b>	<i>D</i> 127.000	B154, B156
<b>42687</b>	<i>d</i> 76.200	B154
<b>42688</b>	<i>d</i> 76.200	B154

Bearing No. CONE, CUP	Nominal Dimension (mm) <i>d</i> :CONE (Bore Dia.) <i>D</i> :CUP (Outside Dia.)	Pages
<b>42690</b>	<i>d</i> 77.788	B156
<b>43118</b>	<i>d</i> 30.162	B136
<b>43131</b>	<i>d</i> 33.338	B138
<b>43300</b>	<i>D</i> 76.200	B136
<b>43312</b>	<i>D</i> 79.375	B138
<b>44143</b>	<i>d</i> 36.512	B140
<b>44150</b>	<i>d</i> 38.100	B140
<b>44157</b>	<i>d</i> 40.000	B140
<b>44162</b>	<i>d</i> 41.275	B142
<b>44348</b>	<i>D</i> 88.501	B140, B142
<b>L44610</b>	<i>D</i> 50.292	B134
<b>L44640</b>	<i>d</i> 23.812	B134
<b>L44643</b>	<i>d</i> 25.400	B134
<b>L44649</b>	<i>d</i> 26.988	B134
<b>45220</b>	<i>D</i> 104.775	B148
<b>45221</b>	<i>D</i> 104.775	B148
<b>45289</b>	<i>d</i> 57.150	B148
<b>L45410</b>	<i>D</i> 50.292	B136
<b>L45449</b>	<i>d</i> 29.000	B136
<b>46143</b>	<i>d</i> 36.512	B140
<b>46162</b>	<i>d</i> 41.275	B142
<b>46176</b>	<i>d</i> 44.450	B142
<b>46368</b>	<i>D</i> 93.662	B140, B142
<b>46720</b>	<i>D</i> 225.425	B164
<b>46780</b>	<i>d</i> 158.750	B164
<b>47420</b>	<i>D</i> 120.000	B152, B154
<b>47487</b>	<i>d</i> 69.850	B152
<b>47490</b>	<i>d</i> 71.438	B154
<b>47620</b>	<i>D</i> 133.350	B154, B156
<b>47680</b>	<i>d</i> 76.200	B154
<b>47685</b>	<i>d</i> 82.550	B156
<b>47686</b>	<i>d</i> 82.550	B156
<b>47687</b>	<i>d</i> 82.550	B156
<b>47820</b>	<i>D</i> 146.050	B160
<b>47890</b>	<i>d</i> 92.075	B160
<b>47896</b>	<i>d</i> 95.250	B160
<b>48120</b>	<i>D</i> 161.925	B162
<b>48190</b>	<i>D</i> 107.950	B162
<b>48220</b>	<i>D</i> 182.562	B164
<b>48282</b>	<i>d</i> 120.650	B164
<b>48286</b>	<i>d</i> 123.825	B164
<b>48290</b>	<i>d</i> 127.000	B164
<b>48320</b>	<i>D</i> 190.500	B164
<b>48385</b>	<i>D</i> 133.350	B164
<b>48393</b>	<i>d</i> 136.525	B164
<b>LM48510</b>	<i>D</i> 65.088	B138
<b>LM48511</b>	<i>D</i> 65.088	B138
<b>LM48548</b>	<i>d</i> 34.925	B138
<b>48620</b>	<i>D</i> 200.025	B164
<b>48685</b>	<i>d</i> 142.875	B164
<b>49175</b>	<i>d</i> 44.450	B142
<b>49176</b>	<i>d</i> 44.450	B142
<b>49368</b>	<i>D</i> 93.662	B142
<b>49520</b>	<i>D</i> 101.600	B146

Bearing No. CONE, CUP	Nominal Dimension (mm) <i>d</i> :CONE (Bore Dia.) <i>D</i> :CUP (Outside Dia.)	Pages
<b>49585</b>	<i>d</i> 50.800	B146
<b>52387</b>	<i>d</i> 98.425	B160
<b>52393</b>	<i>d</i> 100.012	B160
<b>52400</b>	<i>d</i> 101.600	B162
<b>52618</b>	<i>D</i> 157.162	B160, B162
<b>52637</b>	<i>D</i> 161.925	B160, B162
<b>53150</b>	<i>d</i> 38.100	B140
<b>53162</b>	<i>d</i> 41.275	B142
<b>53176</b>	<i>d</i> 44.450	B144
<b>53177</b>	<i>d</i> 44.450	B144
<b>53178</b>	<i>d</i> 44.450	B144
<b>53375</b>	<i>D</i> 95.250	B140, B144
<b>53387</b>	<i>D</i> 98.425	B142, B144
<b>55175</b>	<i>d</i> 44.450	B144
<b>55187</b>	<i>d</i> 47.625	B144
<b>55200</b>	<i>d</i> 50.800	B146
<b>55200C</b>	<i>d</i> 50.800	B146
<b>55206</b>	<i>d</i> 52.388	B146
<b>55437</b>	<i>D</i> 111.125	B144, B146
<b>55443</b>	<i>D</i> 112.712	B144
<b>56418</b>	<i>d</i> 106.362	B162
<b>56425</b>	<i>d</i> 107.950	B162
<b>56650</b>	<i>D</i> 165.100	B162
<b>59200</b>	<i>d</i> 50.800	B146
<b>59429</b>	<i>D</i> 108.966	B146
<b>64433</b>	<i>d</i> 109.992	B162
<b>64450</b>	<i>d</i> 114.300	B162
<b>64700</b>	<i>D</i> 177.800	B162
<b>65200</b>	<i>d</i> 50.800	B146
<b>65212</b>	<i>d</i> 53.975	B148
<b>65237</b>	<i>d</i> 60.325	B150
<b>65320</b>	<i>D</i> 114.300	B144
<b>65385</b>	<i>d</i> 44.450	B144
<b>65500</b>	<i>D</i> 127.000	B146, B148, B150
<b>66187</b>	<i>d</i> 47.625	B144
<b>66462</b>	<i>D</i> 117.475	B144
<b>66520</b>	<i>D</i> 122.238	B148, B150
<b>66584</b>	<i>d</i> 53.975	B148
<b>66585</b>	<i>d</i> 60.000	B150
<b>66587</b>	<i>d</i> 57.150	B148
<b>LM67010</b>	<i>D</i> 59.131	B134, B136
<b>LM67043</b>	<i>d</i> 28.575	B134
<b>LM67048</b>	<i>d</i> 31.750	B136
<b>67320</b>	<i>D</i> 203.200	B164
<b>67322</b>	<i>D</i> 196.850	B164
<b>67388</b>	<i>d</i> 127.000	B164
<b>67389</b>	<i>d</i> 130.175	B164
<b>67390</b>	<i>d</i> 133.350	B164
<b>67720</b>	<i>D</i> 247.650	B164, B166
<b>67780</b>	<i>d</i> 165.100	B164
<b>67787</b>	<i>d</i> 174.625	B166
<b>67790</b>	<i>d</i> 177.800	B166
<b>67820</b>	<i>D</i> 266.700	B166
<b>67885</b>	<i>d</i> 190.500	B166

Bearing No. CONE, CUP	Nominal Dimension (mm) <i>d</i> :CONE (Bore Dia.) <i>D</i> :CUP (Outside Dia.)	Pages
<b>67920</b>	<i>D</i> 282.575	B166
<b>67983</b>	<i>d</i> 203.200	B166
<b>67985</b>	<i>d</i> 206.375	B166
<b>L68110</b>	<i>D</i> 59.131	B138
<b>L68111</b>	<i>D</i> 59.975	B138
<b>L68149</b>	<i>d</i> 35.000	B138
<b>68450</b>	<i>d</i> 114.300	B162
<b>68462</b>	<i>d</i> 117.475	B162
<b>68709</b>	<i>D</i> 180.000	B162
<b>68712</b>	<i>D</i> 180.975	B162
<b>JL69310</b>	<i>D</i> 63.000	B140
<b>JL69349</b>	<i>d</i> 38.000	B140
<b>71412</b>	<i>d</i> 104.775	B162
<b>71425</b>	<i>d</i> 107.950	B162
<b>71437</b>	<i>d</i> 111.125	B162
<b>71450</b>	<i>d</i> 114.300	B162
<b>71453</b>	<i>d</i> 115.087	B162
<b>71750</b>	<i>D</i> 190.500	B162
<b>72187</b>	<i>d</i> 47.625	B144
<b>72200</b>	<i>d</i> 50.800	B146
<b>72200C</b>	<i>d</i> 50.800	B146
<b>72212</b>	<i>d</i> 53.975	B148
<b>72212C</b>	<i>d</i> 53.975	B148
<b>72218</b>	<i>d</i> 55.562	B148
<b>72218C</b>	<i>d</i> 55.562	B148
<b>72225C</b>	<i>d</i> 57.150	B148
<b>72487</b>	<i>D</i> 123.825	B144, B146, B148
<b>LM72810</b>	<i>D</i> 47.000	B134
<b>LM72849</b>	<i>d</i> 22.606	B134
<b>74500</b>	<i>d</i> 127.000	B164
<b>74525</b>	<i>d</i> 133.350	B164
<b>74537</b>	<i>d</i> 136.525	B164
<b>74550</b>	<i>d</i> 139.700	B164
<b>74850</b>	<i>D</i> 215.900	B164
<b>74856</b>	<i>D</i> 217.488	B164
<b>77375</b>	<i>d</i> 95.250	B160
<b>77675</b>	<i>D</i> 171.450	B160
<b>78225</b>	<i>d</i> 57.150	B148
<b>78250</b>	<i>d</i> 63.500	B150
<b>LM78310</b>	<i>D</i> 62.000	B138
<b>LM78310A</b>	<i>D</i> 62.000	B138
<b>LM78349</b>	<i>d</i> 35.000	B138
<b>78537</b>	<i>D</i> 136.525	B150
<b>78551</b>	<i>D</i> 140.030	B148, B150
<b>78571</b>	<i>D</i> 144.983	B148
<b>HM81610</b>	<i>D</i> 47.000	B132
<b>HM81649</b>	<i>d</i> 16.000	B132
<b>M84210</b>	<i>D</i> 59.530	B134
<b>M84249</b>	<i>d</i> 25.400	B134
<b>M84510</b>	<i>D</i> 57.150	B134
<b>M84548</b>	<i>d</i> 25.400	B134
<b>M86610</b>	<i>D</i> 64.292	B134, B136
<b>M86643</b>	<i>d</i> 25.400	B134
<b>M86647</b>	<i>d</i> 28.575	B134

Bearing No. CONE, CUP	Nominal Dimension (mm) <i>d</i> :CONE (Bore Dia.) <i>D</i> :CUP (Outside Dia.)	Pages
<b>M86648A</b>	<i>d</i> 30.955	B136
<b>M86649</b>	<i>d</i> 30.162	B136
<b>M88010</b>	<i>D</i> 68.262	B136, B138
<b>M88043</b>	<i>d</i> 30.162	B136
<b>M88046</b>	<i>d</i> 31.750	B136
<b>M88048</b>	<i>d</i> 33.338	B138
<b>HM88510</b>	<i>D</i> 73.025	B136, B138
<b>HM88542</b>	<i>d</i> 31.750	B136
<b>HM88547</b>	<i>d</i> 33.338	B138
<b>HM88610</b>	<i>D</i> 72.233	B134, B136, B138, B140
<b>HM88630</b>	<i>d</i> 25.400	B134
<b>HM88638</b>	<i>d</i> 32.000	B136
<b>HM88648</b>	<i>d</i> 35.717	B140
<b>HM88649</b>	<i>d</i> 34.925	B138
<b>HM89410</b>	<i>D</i> 76.200	B138, B140
<b>HM89411</b>	<i>D</i> 76.200	B138
<b>HM89443</b>	<i>d</i> 33.338	B138
<b>HM89444</b>	<i>d</i> 33.338	B138
<b>HM89446</b>	<i>d</i> 34.925	B138
<b>HM89446A</b>	<i>d</i> 34.925	B138
<b>HM89449</b>	<i>d</i> 36.512	B140
<b>99100</b>	<i>D</i> 254.000	B164
<b>99550</b>	<i>d</i> 139.700	B164
<b>99575</b>	<i>d</i> 146.050	B164
<b>99587</b>	<i>d</i> 149.225	B164
<b>99600</b>	<i>d</i> 152.400	B164
<b>LM102910</b>	<i>D</i> 73.431	B144
<b>LM102949</b>	<i>d</i> 45.242	B144
<b>JLM104910</b>	<i>D</i> 82.000	B146
<b>LM104911</b>	<i>D</i> 82.550	B146
<b>LM104911A</b>	<i>D</i> 82.550	B146
<b>LM104912</b>	<i>D</i> 82.931	B146
<b>LM104947A</b>	<i>d</i> 50.000	B146
<b>JLM104948</b>	<i>d</i> 50.000	B146
<b>LM104949</b>	<i>d</i> 50.800	B146
<b>M201011</b>	<i>D</i> 73.025	B140
<b>M201047</b>	<i>d</i> 39.688	B140
<b>JM205110</b>	<i>D</i> 90.000	B146
<b>JM205149</b>	<i>d</i> 50.000	B146
<b>JM207010</b>	<i>D</i> 95.000	B148
<b>JM207049</b>	<i>d</i> 55.000	B148
<b>JH211710</b>	<i>D</i> 120.000	B152
<b>JH211749</b>	<i>d</i> 65.000	B152
<b>HM212010</b>	<i>D</i> 122.238	B150, B152
<b>HM212011</b>	<i>D</i> 122.238	B150, B152
<b>HM212044</b>	<i>d</i> 60.325	B150
<b>HM212046</b>	<i>d</i> 63.500	B150
<b>HM212047</b>	<i>d</i> 63.500	B150
<b>HM212049</b>	<i>d</i> 66.675	B152
<b>JH217210</b>	<i>D</i> 150.000	B158
<b>JH217249</b>	<i>d</i> 85.000	B158
<b>HM218210</b>	<i>D</i> 147.000	B158
<b>HM218248</b>	<i>d</i> 90.000	B158
<b>HH221410</b>	<i>D</i> 190.500	B158, B160, B162

Bearing No. CONE, CUP	Nominal Dimension (mm) <i>d</i> :CONE (Bore Dia.) <i>D</i> :CUP (Outside Dia.)	Pages
<b>HH221432</b>	<i>d</i> 87.312	B158
<b>HH221434</b>	<i>d</i> 88.900	B158
<b>HH221440</b>	<i>d</i> 95.250	B160
<b>HH221442</b>	<i>d</i> 98.425	B160
<b>HH221447</b>	<i>d</i> 99.982	B160
<b>HH221449</b>	<i>d</i> 101.600	B162
<b>HH224310</b>	<i>D</i> 212.725	B162
<b>HH224335</b>	<i>d</i> 101.600	B162
<b>HH224340</b>	<i>d</i> 107.950	B162
<b>HH224346</b>	<i>d</i> 114.300	B162
<b>M224710</b>	<i>D</i> 174.625	B164
<b>M224748</b>	<i>d</i> 120.000	B164
<b>LL225710</b>	<i>D</i> 165.895	B164
<b>LL225749</b>	<i>d</i> 127.000	B164
<b>HM231110</b>	<i>D</i> 236.538	B164
<b>HM231140</b>	<i>d</i> 146.050	B164
<b>M236810</b>	<i>D</i> 260.350	B166
<b>M236849</b>	<i>d</i> 177.800	B166
<b>LM300811</b>	<i>D</i> 68.000	B140
<b>LM300849</b>	<i>d</i> 41.000	B140
<b>L305610</b>	<i>D</i> 80.962	B146
<b>L305649</b>	<i>d</i> 50.800	B146
<b>JH307710</b>	<i>D</i> 110.000	B148
<b>JH307749</b>	<i>d</i> 55.000	B148
<b>JHM318410</b>	<i>D</i> 155.000	B158
<b>JHM318448</b>	<i>d</i> 90.000	B158
<b>L327210</b>	<i>D</i> 177.008	B164
<b>L327249</b>	<i>d</i> 133.350	B164
<b>LM328410</b>	<i>D</i> 187.325	B164
<b>LM328448</b>	<i>d</i> 139.700	B164
<b>H414210</b>	<i>D</i> 136.525	B152, B154
<b>H414245</b>	<i>d</i> 68.262	B152
<b>H414249</b>	<i>d</i> 71.438	B154
<b>JH415610</b>	<i>D</i> 145.000	B154
<b>JH415647</b>	<i>d</i> 75.000	B154
<b>LM501310</b>	<i>D</i> 73.431	B140
<b>LM501314</b>	<i>D</i> 73.431	B140
<b>LM501349</b>	<i>d</i> 41.275	B140
<b>LM503310</b>	<i>D</i> 75.000	B144
<b>LM503349</b>	<i>d</i> 46.000	B144
<b>HH506310</b>	<i>D</i> 114.300	B146
<b>HH506348</b>	<i>d</i> 49.212	B146
<b>JLM506810</b>	<i>D</i> 90.000	B148
<b>JLM506849</b>	<i>d</i> 55.000	B148
<b>JLM508710</b>	<i>D</i> 95.000	B150
<b>JLM508748</b>	<i>d</i> 60.000	B150
<b>JM511910</b>	<i>D</i> 110.000	B152
<b>JM511946</b>	<i>d</i> 65.000	B152
<b>JM515610</b>	<i>D</i> 130.000	B156
<b>JM515649</b>	<i>d</i> 80.000	B156
<b>HM516410</b>	<i>D</i> 133.350	B156
<b>HM516448</b>	<i>d</i> 82.550	B156
<b>JHM516810</b>	<i>D</i> 140.000	B158
<b>JHM516849</b>	<i>d</i> 85.000	B158

Bearing No. CONE, CUP	Nominal Dimension (mm) <i>d</i> :CONE (Bore Dia.) <i>D</i> :CUP (Outside Dia.)	Pages
<b>HM518410</b>	<i>D</i> 152.400	B158
<b>HM518445</b>	<i>d</i> 88.900	B158
<b>LM522510</b>	<i>D</i> 159.987	B162
<b>LM522546</b>	<i>d</i> 107.950	B162
<b>LM522548</b>	<i>d</i> 109.987	B162
<b>LM522549</b>	<i>d</i> 109.987	B162
<b>JHM522610</b>	<i>D</i> 180.000	B162
<b>JHM522649</b>	<i>d</i> 110.000	B162
<b>JHM534110</b>	<i>D</i> 230.000	B166
<b>JHM534149</b>	<i>d</i> 170.000	B166
<b>LM603011</b>	<i>D</i> 77.788	B144
<b>LM603012</b>	<i>D</i> 77.788	B144
<b>LM603049</b>	<i>d</i> 45.242	B144
<b>L610510</b>	<i>D</i> 94.458	B150
<b>L610549</b>	<i>d</i> 63.500	B150
<b>JM612910</b>	<i>D</i> 115.000	B154
<b>JM612949</b>	<i>d</i> 70.000	B154
<b>LM613410</b>	<i>D</i> 112.712	B152
<b>LM613449</b>	<i>d</i> 69.850	B152
<b>HM617010</b>	<i>D</i> 142.138	B158
<b>HM617049</b>	<i>d</i> 85.725	B158
<b>L623110</b>	<i>D</i> 152.400	B162
<b>L623149</b>	<i>d</i> 114.300	B162
<b>JLM710910</b>	<i>D</i> 105.000	B152
<b>JLM710949</b>	<i>d</i> 65.000	B152
<b>JLM714110</b>	<i>D</i> 115.000	B154
<b>JLM714149</b>	<i>d</i> 75.000	B154
<b>JM714210</b>	<i>D</i> 120.000	B154
<b>JM714249</b>	<i>d</i> 75.000	B154
<b>H715311</b>	<i>D</i> 136.525	B150, B152, B154
<b>H715334</b>	<i>d</i> 61.912	B150
<b>H715340</b>	<i>d</i> 65.088	B152
<b>H715341</b>	<i>d</i> 66.675	B152
<b>H715343</b>	<i>d</i> 68.262	B152
<b>H715345</b>	<i>d</i> 71.438	B154
<b>JM716610</b>	<i>D</i> 130.000	B158
<b>JM716648</b>	<i>d</i> 85.000	B158
<b>JM716649</b>	<i>d</i> 85.000	B158
<b>JM718110</b>	<i>D</i> 145.000	B158
<b>JM718149</b>	<i>d</i> 90.000	B158
<b>JM719113</b>	<i>D</i> 150.000	B160
<b>JM719149</b>	<i>d</i> 95.000	B160
<b>JM720210</b>	<i>D</i> 155.000	B160
<b>JHM720210</b>	<i>D</i> 160.000	B160
<b>JM720249</b>	<i>d</i> 100.000	B160
<b>JHM720249</b>	<i>d</i> 100.000	B160
<b>JL724314</b>	<i>D</i> 170.000	B164
<b>JL724348</b>	<i>d</i> 120.000	B164
<b>JL725316</b>	<i>D</i> 175.000	B164
<b>JL725346</b>	<i>d</i> 125.000	B164
<b>JM734410</b>	<i>D</i> 240.000	B166
<b>JM734449</b>	<i>d</i> 170.000	B166
<b>JM738210</b>	<i>D</i> 260.000	B166
<b>JM738249</b>	<i>d</i> 190.000	B166

Bearing No. CONE, CUP	Nominal Dimension (mm) <i>d</i> :CONE (Bore Dia.) <i>D</i> :CUP (Outside Dia.)	Pages
<b>HM801310</b>	<i>D</i> 82.550	B140
<b>HM801346</b>	<i>d</i> 38.100	B140
<b>M802011</b>	<i>D</i> 82.550	B142
<b>M802048</b>	<i>d</i> 41.275	B142
<b>HM803110</b>	<i>D</i> 88.900	B142
<b>HM803145</b>	<i>d</i> 41.275	B142
<b>HM803146</b>	<i>d</i> 41.275	B142
<b>HM803149</b>	<i>d</i> 44.450	B142
<b>M804010</b>	<i>D</i> 88.900	B144
<b>M804049</b>	<i>d</i> 47.625	B144
<b>HM804810</b>	<i>D</i> 95.250	B142, B144, B146
<b>HM804840</b>	<i>d</i> 41.275	B142
<b>HM804843</b>	<i>d</i> 44.450	B144
<b>HM804846</b>	<i>d</i> 47.625	B144
<b>HM804848</b>	<i>d</i> 48.412	B146
<b>HM804849</b>	<i>d</i> 48.412	B146
<b>HM807010</b>	<i>D</i> 104.775	B144, B146
<b>HM807011</b>	<i>D</i> 104.775	B146
<b>JHM807012</b>	<i>D</i> 105.000	B146
<b>HM807040</b>	<i>d</i> 44.450	B144
<b>HM807044</b>	<i>d</i> 49.212	B146
<b>JHM807045</b>	<i>d</i> 50.000	B146
<b>HM807046</b>	<i>d</i> 50.800	B146
<b>JLM813010</b>	<i>D</i> 110.000	B154
<b>JLM813049</b>	<i>d</i> 70.000	B154
<b>JLM820012</b>	<i>D</i> 150.000	B160
<b>JLM820048</b>	<i>d</i> 100.000	B160
<b>JM822010</b>	<i>D</i> 165.000	B162
<b>JM822049</b>	<i>d</i> 110.000	B162
<b>JHM840410</b>	<i>D</i> 300.000	B166
<b>JHM840449</b>	<i>d</i> 200.000	B166
<b>HM903210</b>	<i>D</i> 95.250	B144
<b>HM903247</b>	<i>d</i> 44.450	B144
<b>HM903249</b>	<i>d</i> 44.450	B144
<b>HM911210</b>	<i>D</i> 130.175	B148
<b>HM911242</b>	<i>d</i> 53.975	B148
<b>H913810</b>	<i>D</i> 146.050	B150, B152
<b>H913842</b>	<i>d</i> 61.912	B150
<b>H913849</b>	<i>d</i> 69.850	B152

