

# Ball Bearing Units Stainless Series

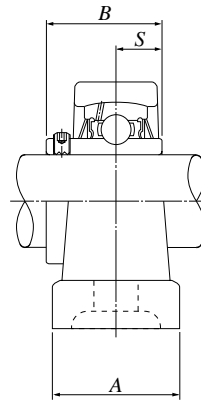

# Pillow type ball bearing unit ; F-UCPM2 series

Cylindrical bore, set screw type with molded-oil

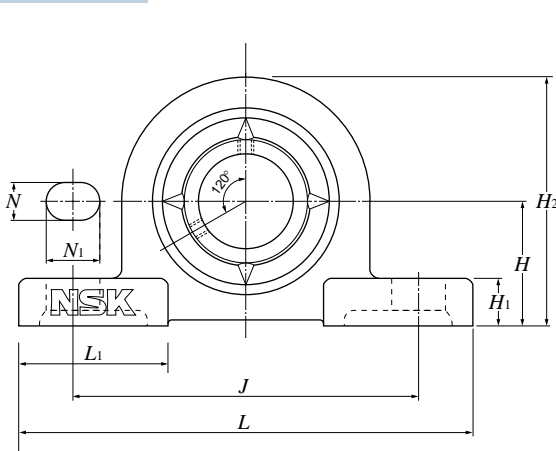

Shaft dia. mm inch	Unit number	Nominal dimensions											Bolt size	Bearing number	Housing number	Mass of unit (Ref.) kg lb
		mm		inch												
		H	L	J	A	N	N <sub>1</sub>	H <sub>1</sub>	H <sub>2</sub>	L <sub>1</sub>	B	S				
20 3/4	F-UCPM204/LP99	33.3	120	95	30	12	14	11	64	42	31	12.7	M10	F-UC204D1/LP99	PM204	0.6
	F-UCPM204-012/LP99	1 5/16	4 23/32	3 3/4	1 3/16	15/32	9/16	7/16	2 17/32	1 21/32	1.2205	0.500	3/8	F-UC204-012D1/LP99	PM204	1.3
25 13/16 7/8 15/16 1	F-UCPM205/LP99	36.5	130	105	30	12	14	12	70	42	34.1	14.3	M10	F-UC205D1/LP99	PM205	0.7
	F-UCPM205-013/LP99	1 7/16	5 1/8	4 1/8	1 3/16	15/32	9/16	15/32	2 3/4	1 21/32	1.3425	0.563	3/8	F-UC205-013D1/LP99	PM205	1.5
	F-UCPM205-014/LP99													F-UC205-014D1/LP99		
	F-UCPM205-015/LP99													F-UC205-015D1/LP99		
	F-UCPM205-100/LP99													F-UC205-100D1/LP99		
30 1 1/16 1 1/8 1 3/16 1 1/4	F-UCPM206/LP99	42.9	155	121	36	17	20	13	82	54	38.1	15.9	M14	F-UC206D1/LP99	PM206	1.0
	F-UCPM206-101/LP99	1 11/16	6 3/32	4 3/4	1 13/32	21/32	25/32	1/2	3 7/32	2 1/8	1.5000	0.626	1/2	F-UC206-101D1/LP99	PM206	2.2
	F-UCPM206-102/LP99													F-UC206-102D1/LP99		
	F-UCPM206-103/LP99													F-UC206-103D1/LP99		
	F-UCPM206-104/LP99													F-UC206-104D1/LP99		
35 1 1/4 1 5/16 1 3/8 1 7/16	F-UCPM207/LP99	47.6	161	127	38	17	20	14	92	54	42.9	17.5	M14	F-UC207D1/LP99	PM207	1.3
	F-UCPM207-104/LP99	1 7/8	6 11/32	5	1 1/2	21/32	25/32	9/16	3 5/8	2 1/8	1.6890	0.689	1/2	F-UC207-104D1/LP99	PM207	2.9
	F-UCPM207-105/LP99													F-UC207-105D1/LP99		
	F-UCPM207-106/LP99													F-UC207-106D1/LP99		
	F-UCPM207-107/LP99													F-UC207-107D1/LP99		
40 1 1/2 1 9/16	F-UCPM208/LP99	49.2	171	137	40	17	20	14	98	52	49.2	19	M14	F-UC208D1/LP99	PM208	1.8
	F-UCPM208-108/LP99	1 15/16	6 23/32	5 13/32	1 9/16	21/32	25/32	9/16	3 27/32	2 1/16	1.9370	0.748	1/2	F-UC208-108D1/LP99	PM208	4.0
	F-UCPM208-109/LP99													F-UC208-109D1/LP99		
45 1 5/8 1 11/16 1 3/4	F-UCPM209/LP99	54	180	146	40	17	20	14	105	60	49.2	19	M14	F-UC209D1/LP99	PM209	2.1
	F-UCPM209-110/LP99	2 1/8	7 3/32	5 3/4	1 9/16	21/32	25/32	9/16	4 1/8	2 3/8	1.9370	0.748	1/2	F-UC209-110D1/LP99	PM209	4.6
	F-UCPM209-111/LP99													F-UC209-111D1/LP99		
	F-UCPM209-112/LP99													F-UC209-112D1/LP99		
50 1 13/16 1 7/8 1 15/16 2	F-UCPM210/LP99	57.2	195	159	45	19	22	16	114	65	51.6	19	M16	F-UC210D1/LP99	PM210	2.5
	F-UCPM210-113/LP99	2 1/4	7 11/16	6 1/4	1 25/32	3/4	7/8	5/8	4 1/2	2 9/16	2.0315	0.748	5/8	F-UC210-113D1/LP99	PM210	5.5
	F-UCPM210-114/LP99													F-UC210-114D1/LP99		
	F-UCPM210-115/LP99													F-UC210-115D1/LP99		
	F-UCPM210-200/LP99													F-UC210-200D1/LP99		

## Housing tolerances (JIS B 1559)

### 1. Tolerances for spherical bore of housing.

Unit:  $\mu$ m/0.0001 inch

Housing number (PM, FM)	Tolerance class J7	
	$D_a$ Deviation $\Delta D_{am}$	
	High	Low
204	+14	-11
	+ 6	- 4
205 ~ 208	+18	-12
	+ 7	- 5
209 , 210	+22	-13
	+ 9	- 5

$\Delta D_{am}$ ; Mean spherical bore diameter deviations.

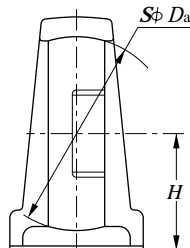

### 2. Center height tolerances for pillow type bearing unit.

Unit: mm/inch

Housing part number	H deviation $\Delta H_s$
PM204 ~ PM210	$\pm 0.15$ $\pm 0.006$



# Rhombus flange type ball bearing unit ; F-UCFM2 series

Cylindrical bore, set screw type with molded-oil

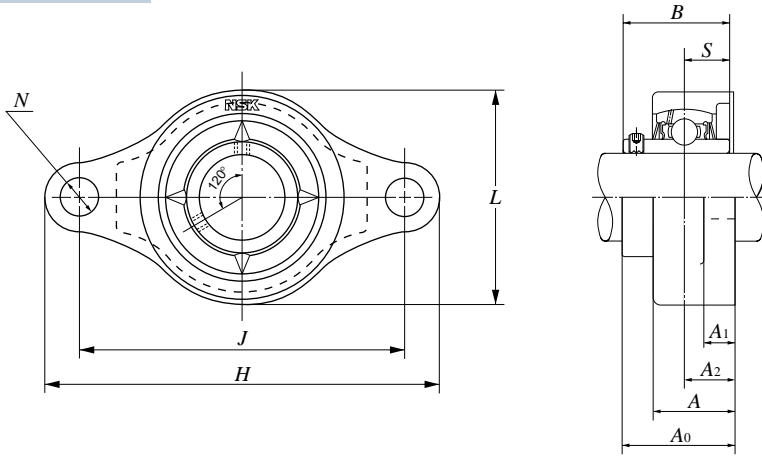

Shaft dia. mm inch	Unit number	Nominal dimensions										Bolt size	Bearing number	Housing number	Mass of unit (Ref.) kg lb
		H	J	A <sub>2</sub>	A <sub>1</sub>	A	N	L	A <sub>0</sub>	B	S				
20 3/4	F-UCFM204/LP99	112	90	15	10	25.5	12	60	33.3	31	12.7	M10	F-UC204D1/LP99	FM204	0.5
	F-UCFM204-012/LP99	4 13/32	3 35/64	19/32	13/32	1	15/32	2 3/8	1 5/16	1.2205	0.500	M10 3/8	F-UC204-012D1/LP99	FM204	1.1
25 13/16 7/8 15/16 1	F-UCFM205/LP99	127	99	16	10	26.5	16	68	35.8	34.1	14.3	M14	F-UC205D1/LP99	FM205	0.6
	F-UCFM205-013/LP99	5	3 57/64	5/8	13/32	1 1/32	5/8	2 11/16	1 13/32	1.3425	0.563	1/2	F-UC205-013D1/LP99	FM205	1.3
	F-UCFM205-014/LP99												F-UC205-014D1/LP99		
	F-UCFM205-015/LP99												F-UC205-015D1/LP99		
	F-UCFM205-100/LP99												F-UC205-100D1/LP99		
30 1 1/16 1 1/8 1 3/16 1 1/4	F-UCFM206/LP99	145	117	18	10	30	16	80	40.2	38.1	15.9	M14	F-UC206D1/LP99	FM206	0.9
	F-UCFM206-101/LP99	5 23/32	4 39/64	45/64	13/32	1 3/16	5/8	3 5/32	1 37/64	1.5000	0.626	1/2	F-UC206-101D1/LP99	FM206	2.0
	F-UCFM206-102/LP99												F-UC206-102D1/LP99		
	F-UCFM206-103/LP99												F-UC206-103D1/LP99		
	F-UCFM206-104/LP99												F-UC206-104D1/LP99		
35 1 1/4 1 5/16 1 3/8 1 7/16	F-UCFM207/LP99	158	130	19	12	32	16	90	44.4	42.9	17.5	M14	F-UC207D1/LP99	FM207	1.2
	F-UCFM207-104/LP99	6 7/32	5 1/8	3/4	15/32	1 1/4	5/8	3 17/32	1 3/4	1.6890	0.689	1/2	F-UC207-104D1/LP99	FM207	2.6
	F-UCFM207-105/LP99												F-UC207-105D1/LP99		
	F-UCFM207-106/LP99												F-UC207-106D1/LP99		
	F-UCFM207-107/LP99												F-UC207-107D1/LP99		
40 1 1/2 1 9/16	F-UCFM208/LP99	172	144	21	12	35	16	100	51.2	49.2	19	M14	F-UC208D1/LP99	FM208	1.6
	F-UCFM208-108/LP99	6 23/32	5 43/64	53/64	15/32	1 3/8	5/8	3 15/16	2 1/64	1.9370	0.748	1/2	F-UC208-108D1/LP99	FM208	3.5
	F-UCFM208-109/LP99												F-UC208-109D1/LP99		
45 1 5/8 1 11/16 1 3/4	F-UCFM209/LP99	180	148	22	13	36	19	108	52.2	49.2	19	M16	F-UC209D1/LP99	FM209	1.9
	F-UCFM209-110/LP99	7 3/32	5 53/64	55/64	1/2	1 13/32	3/4	4 1/4	2 1/16	1.9370	0.748	5/8	F-UC209-110D1/LP99	FM209	4.2
	F-UCFM209-111/LP99												F-UC209-111D1/LP99		
	F-UCFM209-112/LP99												F-UC209-112D1/LP99		
50 1 13/16 1 7/8 1 15/16 2	F-UCFM210/LP99	189	157	22	13	37	19	115	54.6	51.6	19	M16	F-UC210D1/LP99	FM210	2.2
	F-UCFM210-113/LP99	7 7/16	6 3/16	55/64	1/2	1 15/32	3/4	4 17/32	2 5/32	2.0315	0.748	5/8	F-UC210-113D1/LP99	FM210	4.9
	F-UCFM210-114/LP99												F-UC210-114D1/LP99		
	F-UCFM210-115/LP99												F-UC210-115D1/LP99		
	F-UCFM210-200/LP99												F-UC210-200D1/LP99		

## Housing tolerances (JIS B 1559)

### 3. Tolerances for rhombus flange type housing.

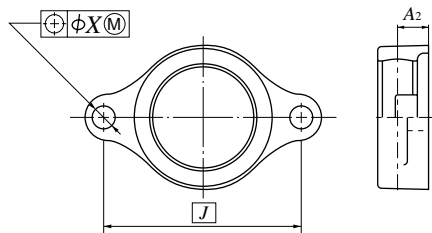

Unit: mm/inch

Housing number	A <sub>2</sub> deviation ΔA <sub>2s</sub>	Tolerances for mounting bolt holes X
FM204 ~ FM210	±0.5	0.7
	±0.020	0.028

A<sub>2</sub> is distance between the center line of spherical bore diameter of the housing.  
J is the bolt hole's center line dimension.

### Recommended tightening torque for set screw

Tighten the two set screws uniformly using the torque listed in this table. Over tightening the set screw may cause the inner ring to crack.

Unit: N·m/lbf·inch

Bearing number (F-UC)	Designation of set screws (W shape screw head)	Tightening torques (Max)
204, 205	M5×0.8	3.9
	No. 10-32UNF	34
206	M6×0.75	4.9
	1/4-28UNF	43
207	M6×0.75	5.8
	1/4-28UNF	52
208~210	M8×1	7.8
	5/16-24UNF	69

# Stainless insert bearing

Cylindrical bore, set screw type with molded-oil

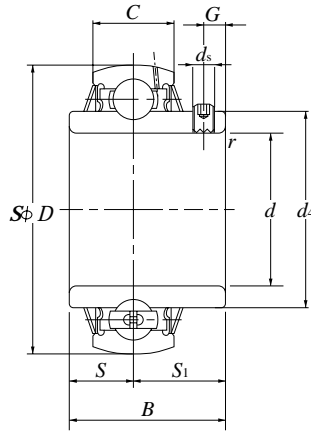

Shaft dia. mm inch	Bearing number	Nominal dimensions										Basic load rating		Mass (Ref.) kg lb
		<i>d</i>	<i>D</i>	<i>B</i>	<i>C</i>	<i>r</i> <sub>s min</sub>	<i>S</i>	<i>S</i> <sub>1</sub>	<i>G</i>	<i>d</i> <sub>s</sub>	<i>d</i> <sub>4</sub>	N dynamic <i>C</i> <sub>r</sub>	lbf static <i>C</i> <sub>or</sub>	
20 3/4	F-UC204D1/LP99	20	47	31	17	1	12.7	18.3	4.5	M5×0.8	29.6	9 900	6 650	0.17
	F-UC204-012D1/LP99	0.7500	1.8504	1.2205	0.6693	0.039	0.500	0.720	0.177	No.10-32UNF	1.1654	2 220	1 500	0.39
25 13/16 7/8 15/16 1	F-UC205D1/LP99	25	52	34.1	17	1	14.3	19.8	5	M5×0.8	33.9	10 800	7 850	0.20
	F-UC205-013D1/LP99	0.8125	2.0472	1.3425	0.6693	0.039	0.563	0.780	0.197	No.10-32UNF	1.3346	2 430	1 770	0.53
	F-UC205-014D1/LP99	0.8750												
	F-UC205-015D1/LP99	0.9375												
F-UC205-100D1/LP99	1.0000													
30 1 1/16 1 1/8 1 3/16 1 1/4	F-UC206D1/LP99	30	62	38.1	19	1	15.9	22.2	5	M6×0.75	40.8	15 000	11 300	0.33
	F-UC206-101D1/LP99	1.0625	2.4409	1.5000	0.7480	0.039	0.626	0.874	0.197	1/4-28UNF	1.6063	3 350	2 540	0.82
	F-UC206-102D1/LP99	1.1250												
	F-UC206-103D1/LP99	1.1875												
F-UC206-104D1/LP99	1.2500													
35 1 1/4 1 5/16 1 3/8 1 7/16	F-UC207D1/LP99	35	72	42.9	20	1.5	17.5	25.4	6	M6×0.75	46.8	19 700	15 300	0.49
	F-UC207-104D1/LP99	1.2500	2.8346	1.6890	0.7874	0.059	0.689	1.000	0.236	1/4-28UNF	1.8425	4 450	3 450	1.21
	F-UC207-105D1/LP99	1.3125												
	F-UC207-106D1/LP99	1.3750												
F-UC207-107D1/LP99	1.4375													
40 1 1/2 1 9/16	F-UC208D1/LP99	40	80	49.2	21	1.5	19	30.2	8	M8×1	53	22 400	17 800	0.65
	F-UC208-108D1/LP99	1.5000	3.1496	1.9370	0.8268	0.059	0.748	1.189	0.315	5/16-24UNF	2.0866	5 050	4 000	1.52
	F-UC208-109D1/LP99	1.5625												
	1.6250													
45 1 5/8 1 11/16 1 3/4	F-UC209D1/LP99	45	85	49.2	22	1.5	19	30.2	8	M8×1	57.5	25 200	20 400	0.70
	F-UC209-110D1/LP99	1.6250	3.3465	1.9370	0.8661	0.059	0.748	1.189	0.315	5/16-24UNF	2.2638	5 650	4 600	1.76
	F-UC209-111D1/LP99	1.6875												
F-UC209-112D1/LP99	1.7500													
50 1 13/16 1 7/8 1 15/16 2	F-UC210D1/LP99	50	90	51.6	24	1.5	19	32.6	9	M8×1	62.4	27 000	23 200	0.80
	F-UC210-113D1/LP99	1.8125	3.5433	2.0315	0.9449	0.059	0.748	1.283	0.354	5/16-24UNF	2.4567	6 050	5 200	2.03
	F-UC210-114D1/LP99	1.8750												
	F-UC210-115D1/LP99	1.9375												
F-UC210-200D1/LP99	2.0000													

Note) Insert bearings can be supplied with USDA qualified food grade grease. The resulting grease suffix is "L458". Ex. F-UC204 D1/L458.

Grease name	Allowable temp. range.	Applications	Note
High temp. Food grade grease.	-20~+110°C ●	Food processing and general machines.	H-1 standard grease qualified by USDA.

● Heat-resistant bearing can be used up to 200°C

## Unit ball bearing tolerances (JIS B 1558)

### 1. Inner ring tolerances.

Unit: μm/0.0001 inch

Nominal bore diameter <i>d</i>				Bore diameter			Width		Radial runout (ref.)
over		incl.		Δ <i>d</i> <sub>mp</sub> Deviations		Δ <i>V</i> <sub>dp</sub> Variations	Δ <i>B</i> <sub>s</sub> Deviations (ref.)		
mm	inch	mm	inch	high	low	max.	high	low	
18	0.7087	31.750	1.2500	+18	0	12	0	-120	18
				+7	0	5	0	-47	7
				+21	0	14	0	-120	20
31.750	1.2500	50.800	2.0000	+8	0	6	0	-47	8

Δ*d*<sub>mp</sub>; Mean bore diameter deviation. Δ*V*<sub>dp</sub>; Bore diameter variation.  
Δ*B*<sub>s</sub>; Inner ring width deviation.

### 2. Outer ring tolerances. Unit: μm/0.0001 inch

Nominal outside diameter <i>D</i>				Δ <i>D</i> <sub>m</sub> Deviations		Radial runout (ref.)
over		incl.		high	low	
mm	inch	mm	inch			
30	1.1811	50	1.9685	0	-11	20
				0	-4	8
50	1.9685	80	3.1496	0	-13	25
				0	-5	10
80	3.1496	120	4.7244	0	-15	35
				0	-6	14

Δ*D*<sub>m</sub>; Mean outside diameter deviation.  
The low deviation of outside diameter Δ*D*<sub>m</sub> does not apply within the distance of 1/4 the width of the outer ring from the side.

# This new series from NSK provides corrosion resistance and longer lubrication life in a clean unit with low torque characteristics.

## 1. Features

### Guards against corrosion

NSK Ball Bearing Units in the stainless series feature ball bearings inserted into housings made of stainless that provide superior resistance to corrosion as compared to standard series cast iron units. This series is especially useful in a wide variety of applications because of the rust free properties of the housing.

### Longer lubrication life

Molded-Oil Bearings are lubricated with NSK's own oil-impregnated material, Molded Oil. Molded Oil consists of lubricating oil and polyolefin resin that has an affinity for oil. Oil slowly seeping from this material provides ample lubrication to the bearing for extended periods.

### Maintains a clean operating environment

As oil seeping from the Molded Oil inside the bearing provides sufficient lubrication, troublesome oil refilling is not required and contamination of the surrounding environment is prevented.

### Low torque characteristics

Prior to filling the bearings with Molded Oil, their interior surfaces are specially treated. As a result, bearing torque is not much higher than that of grease-lubricated bearings. (Patent pending)

### Interchangeability

The basic dimensions are the same as current NSK units and are also compatible with units from other manufacturers ISO standard.

## 2. Materials

Parts		Materials
Bearing	Raceways	Martensite stainless steel (equivalent to SUS440C)
	Rolling element	Martensite stainless steel (SUS440C)
	Slinger, Retainer	Austenite stainless steel (SUS304)
	Rubber seal	Nitril rubber
	Set screw (W shape screw head)	Martensite stainless steel (SUS410)
Bearing housing		Austenite stainless steel casting (SCS13)

## 3. Recommended operating temperature and allowable speed

Molded-Oil®Bearings are recommended to operate under -15 to +80°C. However, operating temperature should be below +60°C when the bearing is operated under continuous use.

$dn$  value :  $12 \times 10^4$  max  
( $dn$ =bore diameter in mm  $\times$  speed in  $\text{min}^{-1}$ )

**Remarks:** This recommended operating temperature range and allowable speed is applied to all bearings with Molded-Oil®Bearings. Contact NSK when your application exceeds these recommendations.

## 4. Anti-Corrosion

NSK recommends ratings of ◎ to ○ for optimum corrosion resistance. ◎ ← excellent → poor ▲ △ ×

Materials	Condition	Atmosphere		Water		Acid		
		Dry	Wet	Natural water	Sodium water	Nitric acid	Sulfuric acid	Hydrochloric acid
Martensite stainless steel	JIS.SUS440C, JIS.SUS410	○	△	△	▲	▲	×	×
Austenite stainless steel	JIS.SUS304, JIS.SCS13	◎	◎	◎	○	◎	○	△
High carbon steel	JIS.SUJ2	△	▲	▲	×	×	×	×
Carbon steel, Cast iron		▲	×	×	×	×	×	×

**Remarks:** This data is obtained by observation of the surface conditions of materials. Note that these anti-corrosion capabilities are altered by anti-corrosion surface treatment. Not recommended for use in liquid.

## 5. Applications

Molded-Oil®Bearings are suitable in applications requiring a clean operating environment such as : food processing and packaging machinery, chemical processing machines, etc.

## 6. Option

The stainless series can also be filled with special grease, i. e., food processing grade, high temperature grease, etc. Also, a grease nipple can be applied upon request. Contact NSK for additional information.