

B-3-1.6 Ball Screws for Transfer Equipment

1. Features

● Transporting mechanism

A series with accuracy grades of Ct7 and Ct10 only demonstrates high ball screw performance for transporting mechanism of Cartesian type robots and single axis actuators.

The following types are categorized ball screw for transfer equipment. VFA and RMA types have finished shaft ends. RMS type, R series of RNFTL, RNFBL, RNCT, RNFL, and RNSTL types have blank shaft ends.

Table 1 Classifications of ball screws for transfer equipment

Finished shaft end	VFA type, RMA type
	RMS type
Blank shaft end	R Series
	RNFTL type, RNFBL type
	RNCT type, RNFL type, RNSTL type

● Interchangeable screw shaft and ball nut

Screw shaft and nut assembly components are sold separately, and randomly-matched. The maximum axial play after assembly is shown in the dimension tables.

2. Specifications

(1) Ball recirculation system

Figs. 1, 2, and 3 show the structures of ball return tube, deflector (bridge type), and end cap ball recirculation systems.

Deflector (bridge type) recirculation system has the feature of compact nut outside diameter for small lead. End cap recirculation system is for screws with high helix lead and multiple start threads. Since the leads are in the range larger than 1.3 times of the screw shaft diameter, it is suitable for high-speed operation.

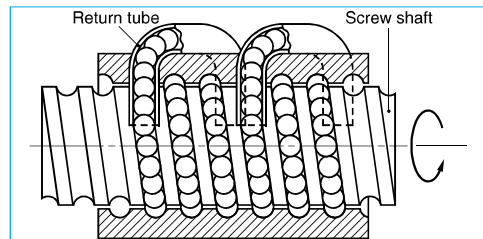

Fig. 1 Structure of return tube recirculation system

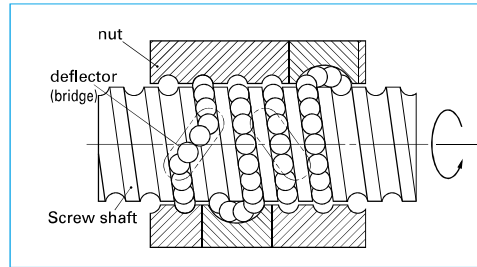

Fig. 2 Structure of deflector (bridge type) recirculation system

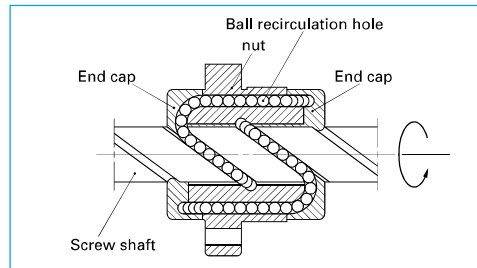

Fig. 3 Structure of end cap recirculation system

(2) Accuracy grade and axial play

Standard lead accuracy and axial play are shown on Table 2. Axial play varies with internal specification. Refer to the dimension tables.

Table 2 Accuracy grade and axial play

Accuracy grade	VFA type, RMA type, RMS type: Ct7 R Series: Ct10
Axial play	See dimension tables

(3) Allowable d·n value and the criterion of maximum rotational speed

Allowable d·n value and the criterion of maximum rotational speed are shown below. Please consult NSK if the rotational speed exceeds the permissible range below.

Table 3 Allowable d·n value and the criterion of maximum rotational speed

Allowable d·n value	50 000 or less
Criterion of maximum rotational speed	3 000 min <sup>-1</sup>

d·n value: shaft dia. d [mm] × rotational speed n [min<sup>-1</sup>]

Note: Please also review the critical speed. See "Technical Description: Permissible Rotational Speed" (page B47) for details.

3. Product categories

Ball screws for transfer equipment have models as follows.

Table 4 Product categories of ball screws for transfer equipment

Nut model	Shape	Flange shape	Recirculation system	Preload system	Page
VFA		Flanged rectangular	Return tube type	Non-preload Slight axial play	353 – B358
RMA RMS		Flanged Circular III	Deflector (bridge) type	Non-preload Slight axial play	B359 – B372
RNFTL		Flanged Circular I Projecting tube type	Return tube type	Non-preload Slight axial play	B373 – B378
RNFBL		Flanged Circular II	Return tube type	Non-preload Slight axial play	B379 – B380
RNCT		V-thread (no flange) Projecting tube type	Return tube type	Non-preload Slight axial play	B381 – B382
RNFL		Flanged Circular III	End cap type	Non-preload Slight axial play	B383 – B386
RNSTL		Square type	Return tube type	Non-preload Slight axial play	B387 – B388

Ball Screws for Transfer Equipment

4. Structure of reference number

The followings describe the structure of "Reference number for ball screw".

◇Reference number for VFA, RMA, and RMS types

VFA 15 10 - C7 S - 500

Ball screw for transfer equipment: VFA, RMA, RMS	Screw shaft length (mm)
Screw shaft diameter (mm)	Axial play
Lead (mm)	Accuracy grade code

◇ Reference number for R series

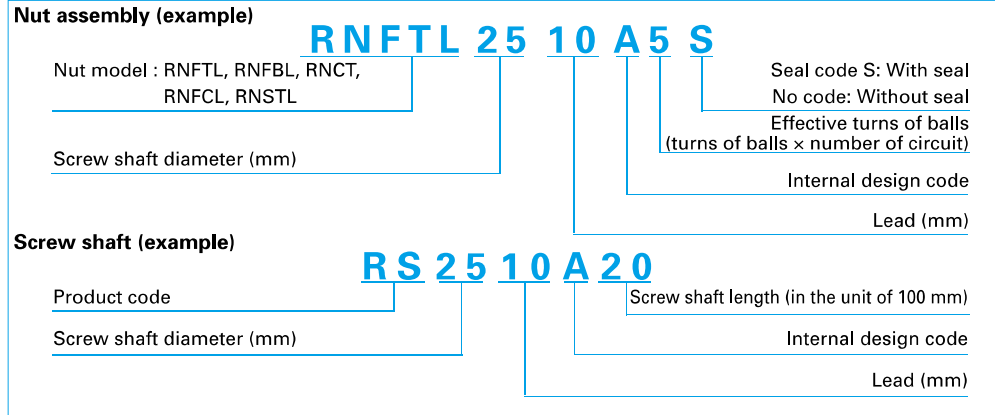

**5. Combinations of shaft diameter and lead**

Combinations of shaft diameter and lead are shown below. For details of standard stock products, contact NSK.

**Table 5 Combinations of shaft diameter and lead for VFA, RMA, RMS types**

Lead	1	1.5	2	10	20
Screw shaft diameter					
6	B359, 371				
8	B361, 371	B363, 371	B365, 371		
10			B367, 371		
12			B369, 371	B353	
15				B355	B357

**Table 6 Combinations of shaft diameter and lead for R series**

Screw shaft diameter (mm)	Lead (mm)															
	3	4	5	6	8	10	12	16	20	25	32	40	50	64	80	
10	○B373 △B381			○B373 ●B379												
12					○B373 ●B379		○B377 ○B383									
14		○B373 ●B379 △B381 ▽B387	○B373 ●B379 △B381 ▽B387													
15									○B383							
16						○B373		○B377 ○B383		○B385						
18				○B373 ●B379 △B381 ▽B387												
20			○B373 ●B379 △B381 ▽B387			○B373 ●B379 △B381 ▽B387			○B377 ○B383	○B385						
25			○B373 ●B379 △B381 ▽B387			○B375 ●B379 △B381 ▽B387			○B377 ○B383		○B385					
28			○B373 ●B379 △B381 ▽B387													
32						○B375 ●B379 △B381 ▽B387				○B377 ○B383		○B385				
36						○B375 ●B379 △B381 ▽B387										
40						○B375 ●B381 ●B379					○B377 ○B383		○B385			
45																
50								○B375 △B381	○B375 △B381				○B383			

○: RNFTL ●: RNFB △: RNCT ◎: RNFL □: RNSTL

**6. Precautions for designing**

As shown in the illustration on Page B83 and B103, general precautions for ball screw.

**(1) Nut assembly**

When delivered, the nut of R series is separated from the screw shaft, and inserted into an arbor shaft. The nut must be inserted to the screw shaft when mounting ball screw.

**(a) Consideration to end configuration of screw shaft**

The balls may fall out during moving the assembled nut from the arbor to the screw shaft if the sizes and shapes of the arbor and the screw shaft are not appropriate.

If the end of the ball groove can touch the end of the arbor, connect both ends and move the assembled nut from the arbor to the screw shaft (Fig. 4).

If the end face of the arbor cannot connect to the end face of the screw because of configuration of both ends of screw shaft, wrap a tape outside of ball screw shaft so that the layers of tape is equal

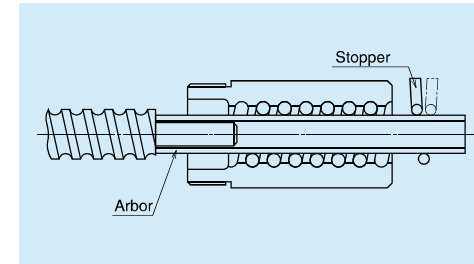

**Fig. 4 Inserting nut into screwshaft**

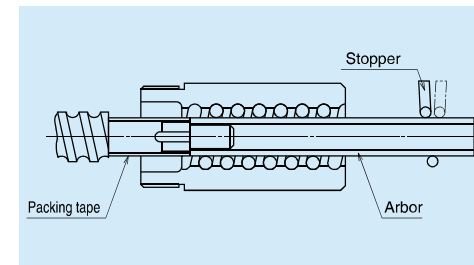

**Fig. 5 Arbor and shaft end configuration**

with the outside diameter of the arbor (Fig. 5). If there is a key way or a nick along the way, fill such gaps prior to moving the ball nut.

**(b) Installation of arbor**

Confirm the correct nut orientation for installation.

Remove the stop ring on the side from where the assembled nut is to be removed. Align the centers of the screw shaft and the arbor while pressing firmly the screw shaft end against the arbor.

**(c) Moving the nut**

Slide the nut until it lightly touches the shoulder of the ball groove section, and stop it. Turn the ball nut to the direction so that it moves to the ball grooves, while pressing the arbor to the screw shaft. Do not separate the arbor from the screw shaft until the ball groove end appears completely in the ball nut.

**(2) Shaft end configuration**

RMS type and R series must be machining of blank shaft ends. See page B27, use of NSK support unit.

**(a) Cutting screw shaft**

Carry out the same process as "(1) Machining of blank shaft ends of precision ball screws" above.

**(b) Annealing the shaft end (Heat the section of the shaft end to be machined with an acetylene torch. Then gradually cool it in ambient atmosphere.)**

\* The area not machined loses hardness if exposed to heat. This may shorten the all screw life. Cool with water the areas where should not be heated to avoid heat conduction.

**(c) Turning by lathe**

Cut to the length, turn shaft end steps, turn thread screw, and provide the center hole. Refer to JIS B1192 which sets standards for the shaft end accuracy.

**(d) Processing by grinding**

Apply the same precautions as for cutting for centering, securing nut, and work rest. Grind sections where the bearings and a "Span ring" are installed.

**(e) Milling processing**

Process keyways and tooth seats for lock washers.

**(f) Deburring, washing, and rust prevention**

Wash with clean white kerosene after processing. Apply lubricant for immediate use. For later use, apply rust preventive agent.

Note: Contact NSK if nut is accidentally removed.

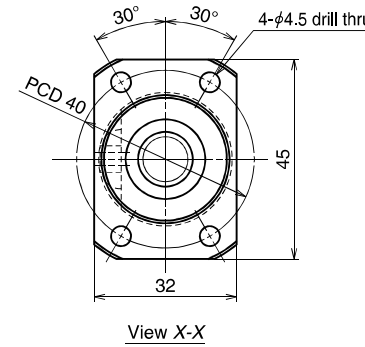
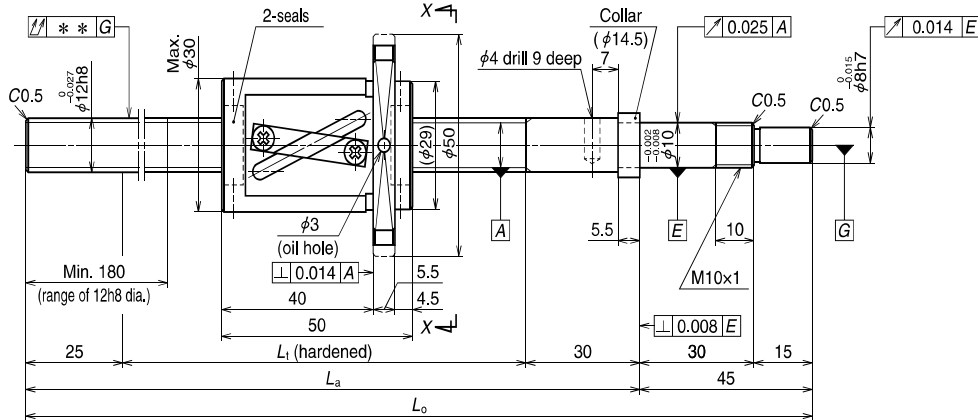

Ball screw specification		
Shaft dia. x Lead / Direction of turn	12 x 10 / Right	
Ball recirculation	Return tube	
Ball dia. / Ball circle dia.	2.381 / 12.5	
Screw shaft root dia.	10.0	
Effective turns of balls	2.5 x 1	
Accuracy grade / Axial play code	Ct7 / S	
Basic load rating (N)	Dynamic $C_d$	3 750
	Static $C_{0a}$	6 480
Axial play	0.010 or less	
Dynamic friction torque (N-cm)	1.5 or less	
Spacer ball	None	
Factory-packed grease	NSK grease LR3	
Internal spatial volume of nut (cm <sup>3</sup> )	1.4	
Reference of grease replenishing amount	0.7	

Recommended support unit

For drive side (Fixed)	For opposite to drive side (Simple)
WBK10-01A (square)	WBK12SF-01 (square)
WBK10-11 (round)	

Ball screw No.	Stroke		Screw shaft length		
	Nominal	Maximum ( $L_t$ -nut length)	$L_t$	$L_a$	$L_o$
VFA1210C7S-410	250	260	310	365	410
VFA1210C7S-610	450	460	510	565	610

Lead accuracy			Shaft run-out**	Mass (kg)	Permissible rotational speed N (min <sup>-1</sup> )	
$T$	$e_p$	$v_{300}$			Supporting condition	
					Fixed - Simple support	Fixed - Free
0	0.085	0.052	0.100	0.56	3 000	3 000
0	0.155	0.052	0.160	0.73	3 000	1 300

- Notes: 1. We recommend NSK support units (page B389). WBK12SF-01 (on simple support side) supports ball screw directly on shaft outside diameter.  
 2. Use of NSK grease LR3 is recommended. Recommended quantity of grease is about 50% of ball nut's internal space. See page D16 for details.  
 3. Permissible rotational speed is determined by  $d \cdot n$  value and critical speed. See pages B47 and B349.

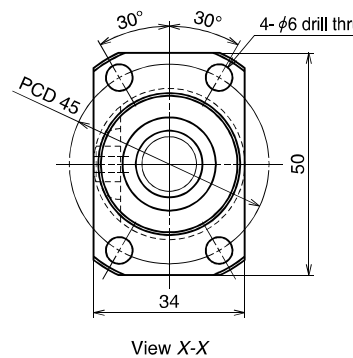
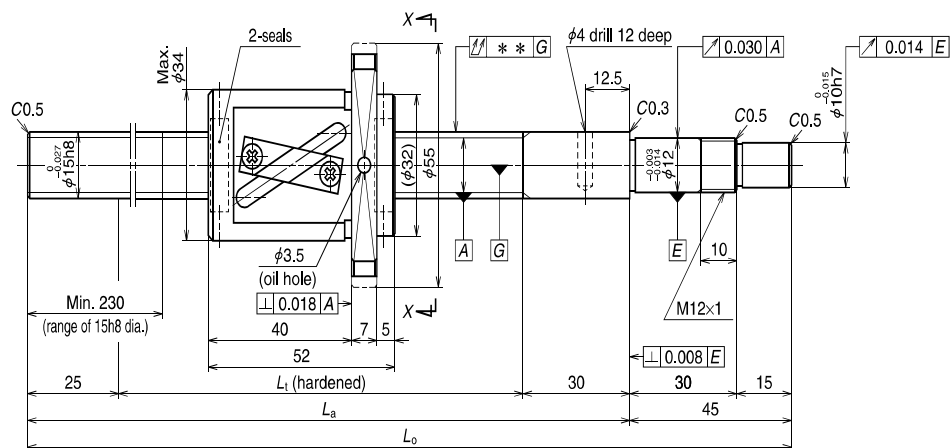

Ball screw specification		
Shaft dia.xLead / Direction of turn	15 x 10 / Right	
Ball recirculation	Return tube	
Ball dia. / Ball circle dia.	3.175 / 15.5	
Screw shaft root dia.	12.2	
Effective turns of balls	2.5 x 1	
Accuracy grade / Axial play code	Ct7 / S	
Basic load rating (N)	Dynamic $C_d$	7 070
	Static $C_{0a}$	12 800
Axial play	0.010 or less	
Dynamic friction torque (N-cm)	2.5 or less	
Spacer ball	None	
Factory-packed grease	NSK grease LR3	
Internal spatial volume of nut (cm <sup>3</sup> )	2.3	
Reference of grease replenishing amount	1.2	

Recommended support unit

For drive side (Fixed)	For opposite to drive side (Simple)
WBK12-01A (square)	WBK15SF-01 (square)
WBK12-11 (round)	

Ball screw No.	Stroke		Screw shaft length		
	Nominal	Maximum ( $L_t$ -nut length)	$L_t$	$L_a$	$L_o$
VFA1510C7S-500	300	348	400	455	500
VFA1510C7S-700	500	548	600	655	700
VFA1510C7S-1000	800	848	900	955	1 000

Lead accuracy			Shaft run-out**	Mass (kg)	Permissible rotational speed N (min <sup>-1</sup> )	
T	$e_p$	$v_{300}$			Supporting condition	
					Fixed - Simple support	Fixed - Free
0	0.120	0.052	0.075	0.89	3 000	2 600
0	0.195	0.052	0.110	1.1	3 000	1 150
0	0.310	0.052	0.180	1.5	2 340	510

- Notes: 1. We recommend NSK support units (page B389), WBK12SF-01 (on simple support side) supports ball screw directly on shaft outside diameter.  
 2. Use of NSK grease LR3 is recommended. Recommended quantity of grease is about 50% of ball nut's internal space. See page D16 for details.  
 3. Permissible rotational speed is determined by  $d \cdot n$  value and critical speed. See pages B47 and B349.

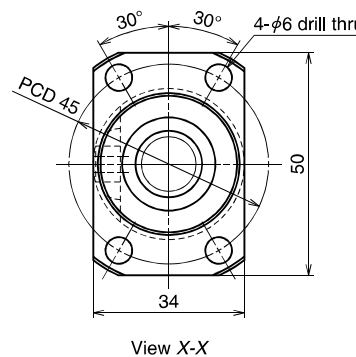
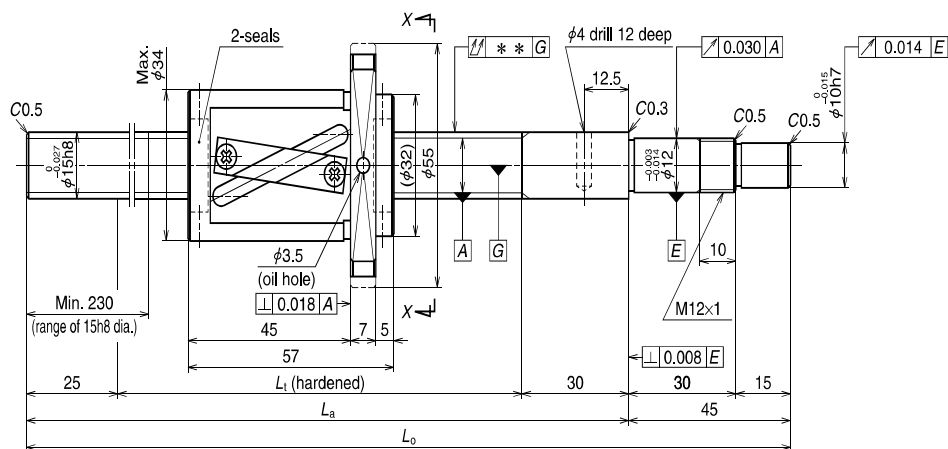

Ball screw specification		
Shaft dia.xLead / Direction of turn	15 x 20 / Right	
Ball recirculation	Return tube	
Ball dia. / Ball circle dia.	3.175 / 15.5	
Screw shaft root dia.	12.2	
Effective turns of balls	1.5 x 1	
Accuracy grade / Axial play code	Ct7 / S	
Basic load rating (N)	Dynamic $C_d$	4 560
	Static $C_{0a}$	7 730
Axial play	0.010 or less	
Dynamic friction torque (N-cm)	2.5 or less	
Spacer ball	None	
Factory-packed grease	NSK grease LR3	
Internal spatial volume of nut (cm <sup>3</sup> )	2.3	
Reference of grease replenishing amount	1.4	

Recommended support unit

For drive side (Fixed)	For opposite to drive side (Simple)
WBK12-01A (square)	WBK15SF-01 (square)
WBK12-11 (round)	

Ball screw No.	Stroke		Screw shaft length		
	Nominal	Maximum ( $L_t$ -nut length)	$L_t$	$L_a$	$L_o$
VFA1520C7S-500	300	343	400	455	500
VFA1520C7S-700	500	543	600	655	700
VFA1520C7S-1000	800	843	900	955	1 000

Lead accuracy			Shaft run-out**	Mass (kg)	Permissible rotational speed N (min <sup>-1</sup> )	
T	$e_p$	$v_{300}$			Supporting condition	
					Fixed - Simple support	Fixed - Free
0	0.120	0.052	0.075	0.94	3 000	2 630
0	0.195	0.052	0.110	1.2	3 000	1 160
0	0.310	0.052	0.180	1.6	2 350	510

- Notes: 1. We recommend NSK support units (page B389), WBK12SF-01 (on simple support side) supports ball screw directly on shaft outside diameter.  
 2. Use of NSK grease LR3 is recommended. Recommended quantity of grease is about 50% of ball nut's internal space. See page D16 for details.  
 3. Permissible rotational speed is determined by  $d \cdot n$  value and critical speed. See pages B47 and B349.

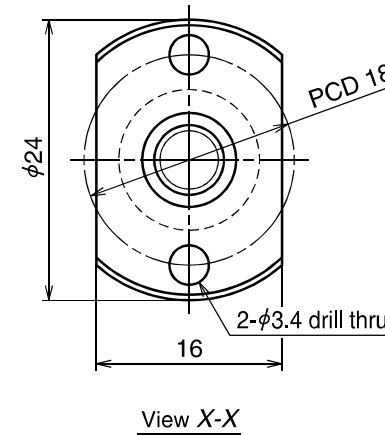
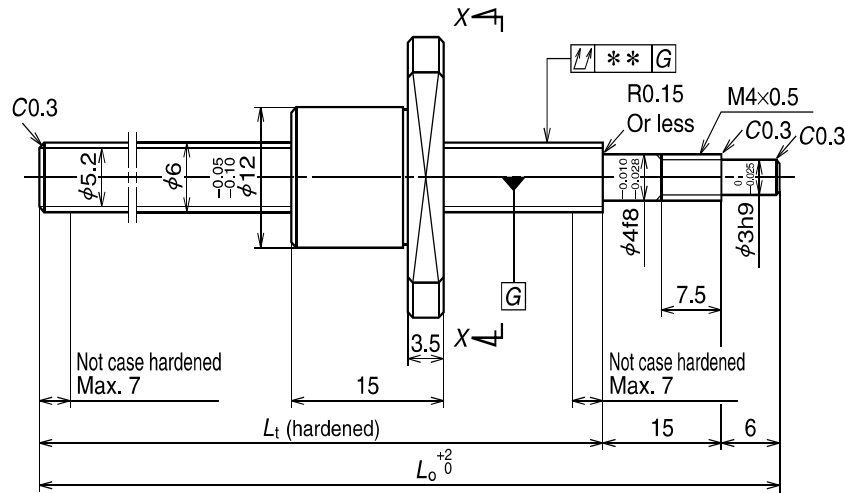

Ball screw specification		
Shaft dia./Lead / Direction of turn	6 x 1 / Right	
Ball recirculation	Deflector (bridge)	
Ball dia. / Ball circle dia.	0.800 / 6.2	
Screw shaft root dia.	5.2	
Effective turns of balls	1 x 3	
Accuracy grade / Axial play code	Ct7 / S	
Basic load rating (N)	Dynamic $C_d$	520
	Static $C_{0a}$	925
Axial play	0.020 or less	
Dynamic friction torque (N-cm)	1.0 or less	
Spacer ball	None	
Factory-packed grease	See Notes 2.	

Recommended support unit

For drive side (Fixed)	
WBK04R-11 (round)	

Ball screw No.	Stroke		Screw shaft length	
	Nominal	Maximum ( $L_t$ -Nut length)	$L_t$	$L_o$
<b>RMA0601C7S-160</b>	100	124	139	160
<b>RMA0601C7S-260</b>	200	224	239	260

Unit: mm

Lead accuracy			Shaft run-out**	Mass (kg)	Permissible rotational speed (N (min <sup>-1</sup> ))
Target compensation $T$	Deviation $e_p$	Variation $v_{300}$			
0	0.052	0.052	0.060	0.045	3 000
0	0.085	0.052	0.090	0.065	3 000

- Notes: 1. We recommend NSK support bearing kit (page B401).  
 2. Only rust preventive oil is applied at time of delivery. Please apply lubricant (oil or grease) before use. See page D13 for details.  
 3. Permissible rotational speed is determined by d-n value and critical speed. See pages B47 and B349.

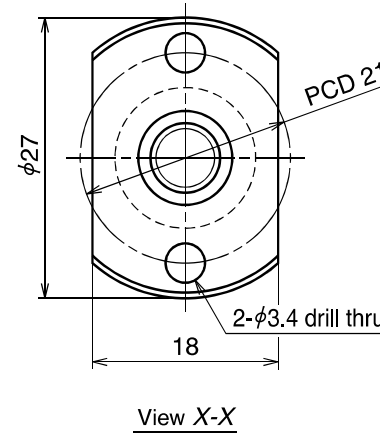
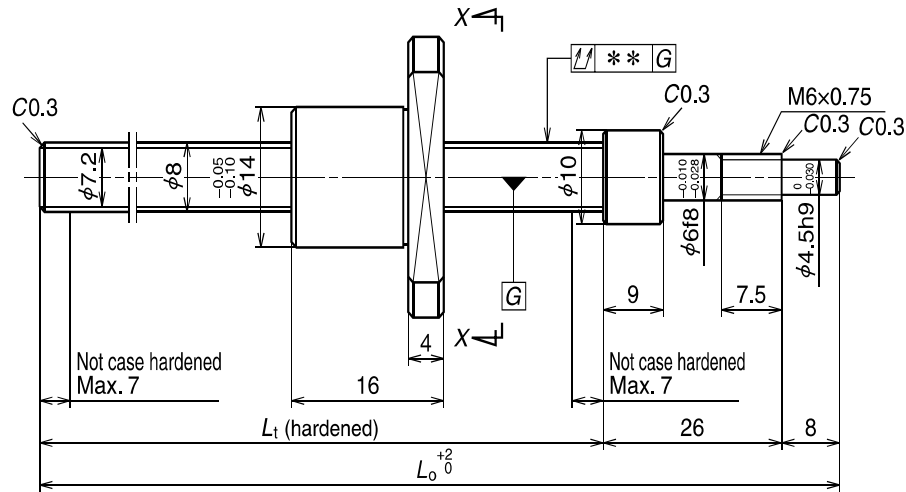

Ball screw specification		
Shaft dia.xLead / Direction of turn	8 × 1 / Right	
Ball recirculation	Deflector (bridge)	
Ball dia. / Ball circle dia.	0.800 / 8.2	
Screw shaft root dia.	7.2	
Effective turns of balls	1 × 3	
Accuracy grade / Axial play code	Ct7 / S	
Basic load rating (N)	Dynamic $C_d$	600
	Static $C_{0a}$	1 290
Axial play	0.020 or less	
Dynamic friction torque (N·cm)	1.0 or less	
Spacer ball	None	
Factory-packed grease	See Notes 2.	

Recommended support unit

For drive side (Fixed)	
WBK06R-11 (round)	

Ball screw No.	Stroke		Screw shaft length	
	Nominal	Maximum ( $L_t$ -Nut length)	$L_t$	$L_o$
<b>RMA0801C7S-180</b>	100	130	146	180
<b>RMA0801C7S-280</b>	200	230	246	280

Lead accuracy			Shaft run-out**	Mass (kg)	Permissible rotational speed N (min <sup>-1</sup> )
Target compensation $T$	Deviation $e_p$	Variation $v_{300}$			
0	0.052	0.052	0.060	0.085	3 000
0	0.085	0.052	0.090	0.12	3 000

- Notes: 1. We recommend NSK support bearing kit (page B401).  
 2. Only rust preventive oil is applied at time of delivery. Please apply lubricant (oil or grease) before use. See page D13 for details.  
 3. Permissible rotational speed is determined by d·n value and critical speed. See pages B47 and B349.

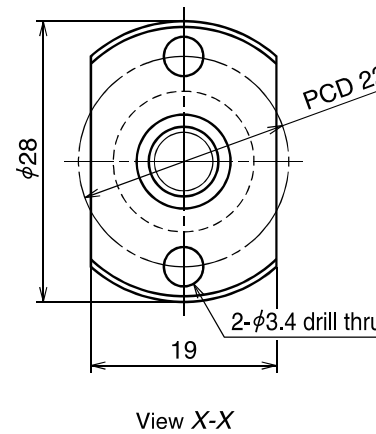
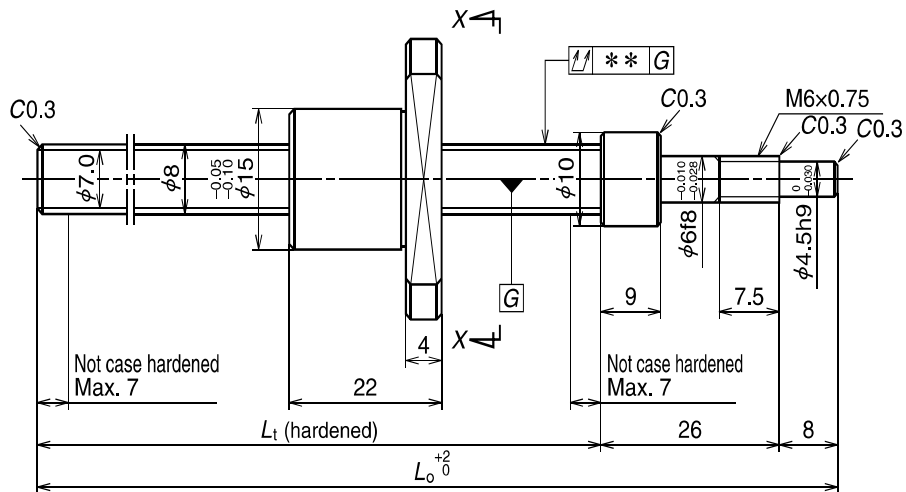

Ball screw specification		
Shaft dia. x Lead / Direction of turn	8 x 1.5 / Right	
Ball recirculation	Deflector (bridge)	
Ball dia. / Ball circle dia.	1.000 / 8.3	
Screw shaft root dia.	7.0	
Effective turns of balls	1 x 3	
Accuracy grade / Axial play code	Ct7 / S	
Basic load rating (N)	Dynamic $C_d$	810
	Static $C_0$	1 590
Axial play	0.020 or less	
Dynamic friction torque (N-cm)	1.0 or less	
Spacer ball	None	
Factory-packed grease	See Notes 2.	

Recommended support unit

For drive side (Fixed)	
WBK06R-11 (round)	

Ball screw No.	Stroke		Screw shaft length	
	Nominal	Maximum ( $L_t$ -Nut length)	$L_t$	$L_o$
<b>RMA0801.5C7S-180</b>	100	124	146	180
<b>RMA0801.5C7S-280</b>	200	224	246	280

Unit: mm

Lead accuracy			Shaft run-out**	Mass (kg)	Permissible rotational speed N (min <sup>-1</sup> )
Target compensation $T$	Deviation $e_p$	Variation $v_{300}$			
0	0.052	0.052	0.060	0.093	3 000
0	0.085	0.052	0.090	0.13	3 000

- Notes: 1. We recommend NSK support bearing kit (page B401).  
 2. Only rust preventive oil is applied at time of delivery. Please apply lubricant (oil or grease) before use. See page D13 for details.  
 3. Permissible rotational speed is determined by d-n value and critical speed. See pages B47 and B349.



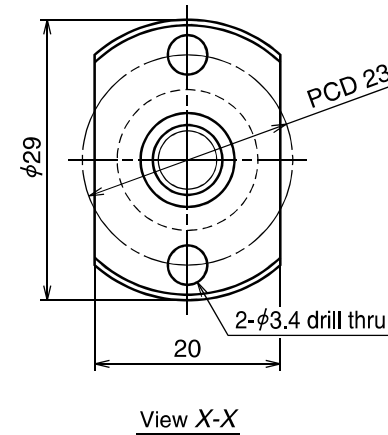
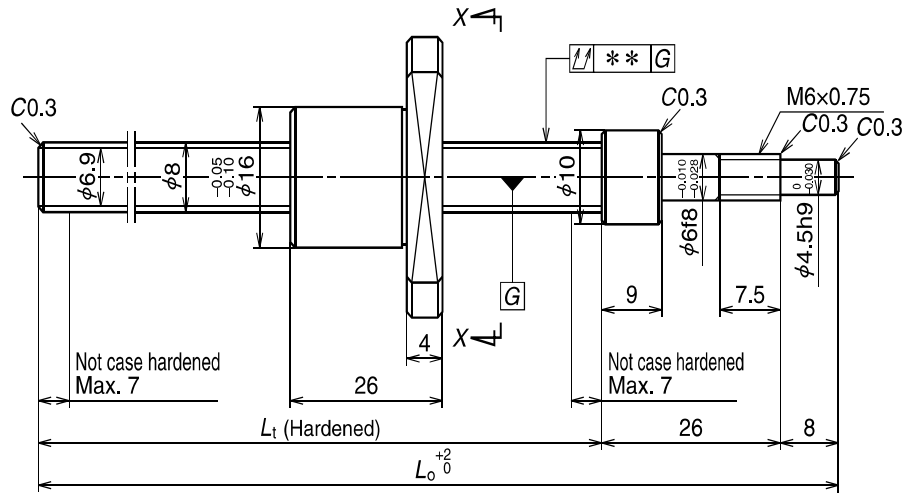

Ball screw specification		
Shaft dia. x Lead / Direction of turn	8 x 2 / Right	
Ball recirculation	Deflector (bridge)	
Ball dia. / Ball circle dia.	1.200 / 8.3	
Screw shaft root dia.	6.9	
Effective turns of balls	1 x 3	
Accuracy grade / Axial play code	Ct7 / S	
Basic load rating (N)	Dynamic $C_d$	1 070
	Static $C_0$	1 950
Axial play	0.020 or less	
Dynamic friction torque (N-cm)	1.0 or less	
Spacer ball	None	
Factory-packed grease	See Notes 2.	

Recommended support unit

For drive side (Fixed)	
WBK06R-11 (round)	

Ball screw No.	Stroke		Screw shaft length	
	Nominal	Maximum ( $L_t$ -Nut length)	$L_t$	$L_o$
<b>RMA0802C7S-180</b>	100	120	146	180
<b>RMA0802C7S-280</b>	200	220	246	280

Lead accuracy			Shaft run-out**	Mass (kg)	Permissible rotational speed N (min <sup>-1</sup> )
Target compensation $T$	Deviation $e_p$	Variation $v_{300}$			
0	0.052	0.052	0.060	0.10	3 000
0	0.085	0.052	0.090	0.14	3 000

- Notes: 1. We recommend NSK support bearing kit (page B401).  
 2. Only rust preventive oil is applied at time of delivery. Please apply lubricant (oil or grease) before use. See page D13 for details.  
 3. Permissible rotational speed is determined by d-n value and critical speed. See pages B47 and B349.

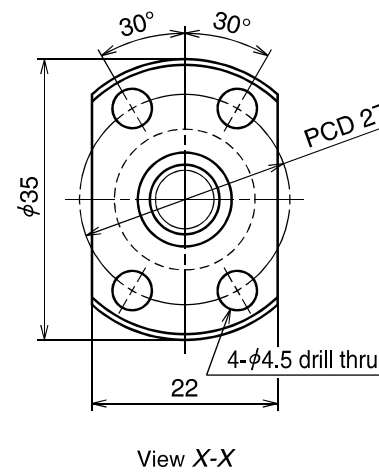
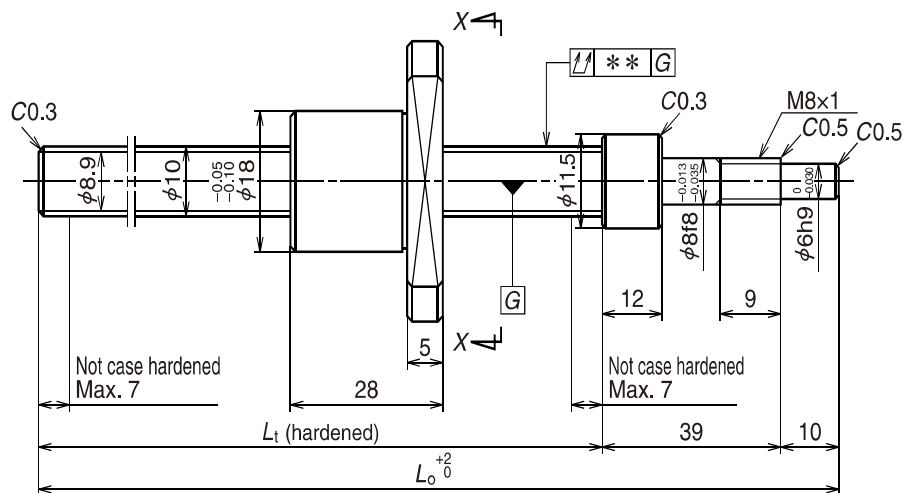

Ball screw specification		
Shaft dia. x Lead / Direction of turn	10 x 2 / Right	
Ball recirculation	Deflector (bridge)	
Ball dia. / Ball circle dia.	1.200 / 10.3	
Screw shaft root dia.	8.9	
Effective turns of balls	1 x 3	
Accuracy grade / Axial play code	Ct7 / S	
Basic load rating (N)	Dynamic $C_d$	1 210
	Static $C_{0a}$	2 510
Axial play	0.020 or less	
Dynamic friction torque (N-cm)	1.0 or less	
Spacer ball	None	
Factory-packed grease	See Notes 2.	

Recommended support unit

For drive side (Fixed)
WBK08-01A (square)
WBK08-11 (round)

Ball screw No.	Stroke		Screw shaft length	
	Nominal	Maximum ( $L_t$ -Nut length)	$L_t$	$L_o$
<b>RMA1002C7S-250</b>	150	173	201	250
<b>RMA1002C7S-350</b>	250	273	301	350

Lead accuracy			Shaft run-out**	Mass (kg)	Permissible rotational speed N (min <sup>-1</sup> )
Target compensation T	Deviation $e_p$	Variation $v_{300}$			
0	0.085	0.052	0.070	0.19	3 000
0	0.085	0.052	0.100	0.25	3 000

- Notes: 1. We recommend NSK support bearing kit (page B389).  
 2. Only rust preventive oil is applied at time of delivery. Please apply lubricant (oil or grease) before use. See page D13 for details.  
 3. Permissible rotational speed is determined by d-n value and critical speed. See pages B47 and B349.

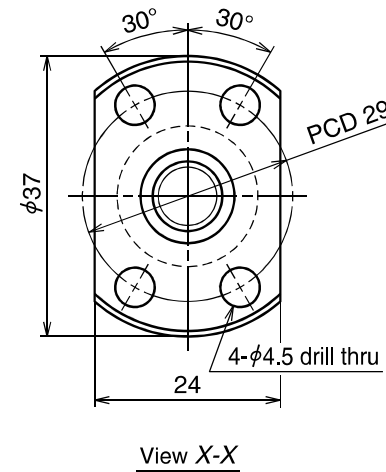
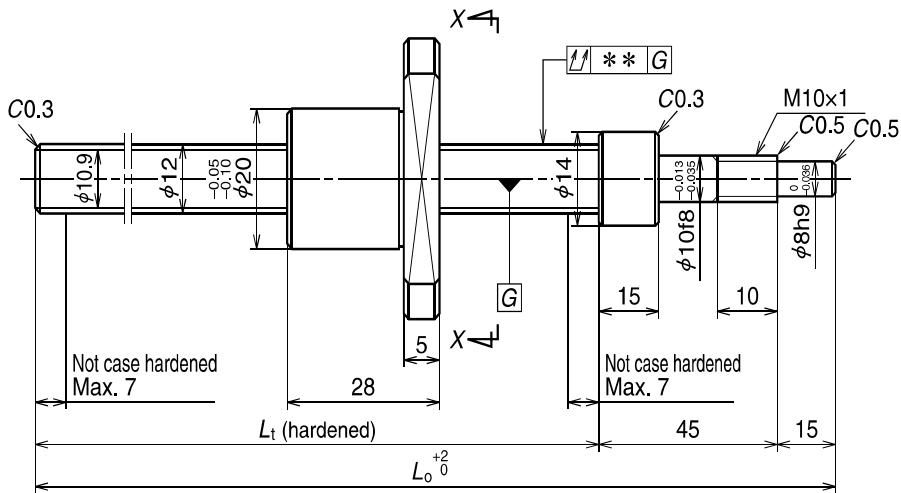

Ball screw specification		
Shaft dia./Lead / Direction of turn	12 x 2 / Right	
Ball recirculation	Deflector (bridge)	
Ball dia. / Ball circle dia.	1.200 / 12.3	
Screw shaft root dia.	10.9	
Effective turns of balls	1 x 3	
Accuracy grade / Axial play code	Ct7 / S	
Basic load rating (N)	Dynamic $C_d$	1 350
	Static $C_{0a}$	3 190
Axial play	0.020 or less	
Dynamic friction torque (N-cm)	1.0 or less	
Spacer ball	None	
Factory-packed grease	See Notes 2.	

Recommended support unit

For drive side (Fixed)	
WBK10-01A (square)	
WBK10-11 (round)	

Ball screw No.	Stroke		Screw shaft length	
	Nominal	Maximum ( $L_t$ -Nut length)	$L_t$	$L_o$
<b>RMA1202C7S-250</b>	150	162	190	250
<b>RMA1202C7S-350</b>	250	262	290	350

Lead accuracy			Shaft run-out**	Mass (kg)	Permissible rotational speed N (min <sup>-1</sup> )
Target compensation $T$	Deviation $e_p$	Variation $v_{300}$			
0	0.060	0.052	0.070	0.26	3 000
0	0.085	0.052	0.100	0.34	3 000

- Notes: 1. We recommend NSK support bearing kit (page B389).  
 2. Only rust preventive oil is applied at time of delivery. Please apply lubricant (oil or grease) before use. See page D13 for details.  
 3. Permissible rotational speed is determined by d-n value and critical speed. See pages B47 and B349.

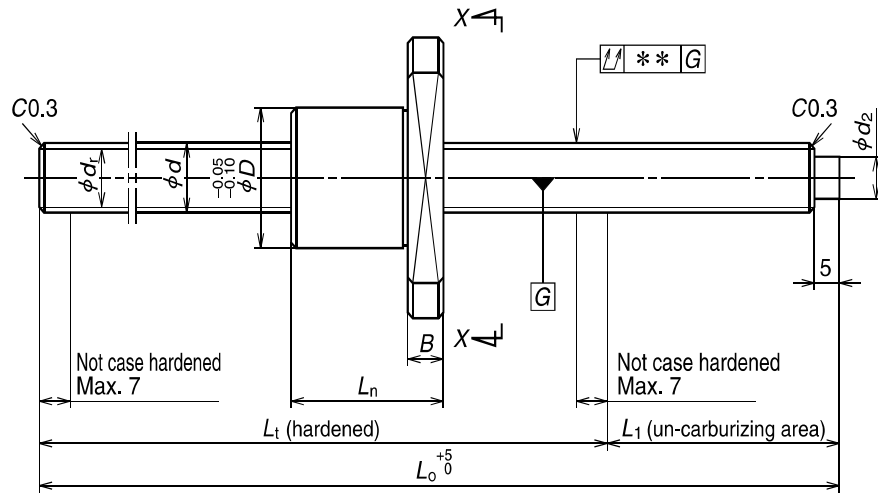

Screw shaft ø6

Lead 1

Screw shaft ø8

Lead 1, 1.5, 2

Screw shaft ø10, ø12

Lead 2

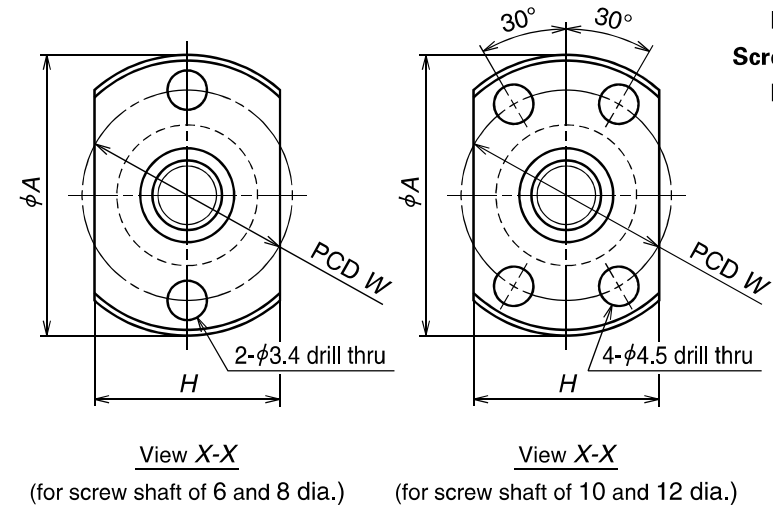

Ball screw No.	Stroke Max. $L_t$ - $L_n$	Shaft dia. $d$	Lead $l$	Ball dia. $D_w$	Ball circle dia. $d_m$	Root dia. $d_r$	Effective turns of balls	Basic load rating (N)		Axial play Max.
								Dynamic $C_o$	Static $C_{o0}$	
<b>RMS0601C7S-300</b>	235	6	1	0.800	6.2	5.3	3	520	925	0.02
<b>RMS0801C7S-300</b>	234	8	1	0.800	8.2	7.3	3	600	1 290	0.02
<b>RMS0801.5C7S-300</b>	228		1.5	1.000	8.3	7.2		810	1 590	
<b>RMS0802C7S-300</b>	224		2	1.200	8.3	7.0		1 070	1 950	
<b>RMS1002C7S-350</b>	262	10	2	1.200	10.3	9.0	3	1 210	2 510	0.02
<b>RMS1202C7S-350</b>	262	12	2	1.200	12.3	11.0	3	1 350	3 190	0.02

Unit: mm

Nut dimensions						Screw shaft dimensions				Lead accuracy			Shaft run-out**	Mass (Kg)	Permissible rotational speed N (min <sup>-1</sup> )
$D$	$A$	$H$	$B$	$L_n$	$W$	Effective thread length $L_t$	Shaft end $L_1$ $d_2$		Overall length $L_n$	Target compensation $T$	Deviation $e_p$	Variation $v_{300}$			
12	24	16	3.5	15	18	250	50	4	300	0	0.085	0.052	0.09	0.075	3 000
14	27	18	4	16	21	250	50	6	300	0	0.085	0.052	0.09	0.13	
15	28	19		22	22									0.14	
16	29	20		26	23									0.15	
18	35	22	5	28	27	290	60	8	350	0	0.085	0.052	0.10	0.25	
20	37	24	5	28	29	290	60	10	350	0	0.085	0.052	0.10	0.35	

- Notes: 1. We recommend NSK support unit (page B389) or support kit (page B401).  
 2. Only rust preventive agent is applied at time of delivery. Please apply lubricant (oil or grease) before use. See page D13 for details.  
 3. Seal is not installed.  
 4. Permissible rotational speed is determined by d-n value and critical speed. See pages B47 and B349.

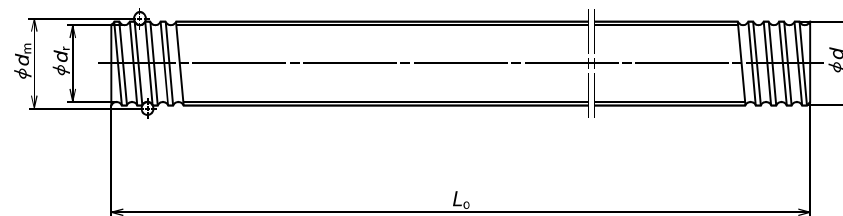
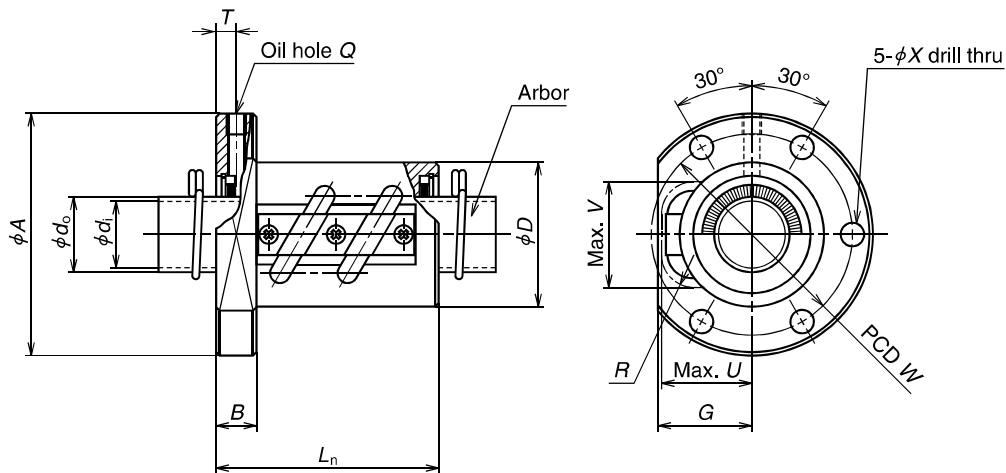

Ball nut No.	Shaft dia. <i>d</i>	Lead <i>l</i>	Ball dia. <i>D<sub>b</sub></i>	Ball circle dia. <i>d<sub>m</sub></i>	Root dia. <i>d<sub>r</sub></i>	Effective turns of balls Turns × Circuits	Basic load rating (N)		Axial play Max.	Ball nut dimensions Outside dia. <i>D</i>
							Dynamic <i>C<sub>n</sub></i>	Static <i>C<sub>0n</sub></i>		
<b>RNFTL 1003A3.5</b>	10	3	2.381	10.65	8.1	3.5×1	3 780	6 730	0.10	20
<b>RNFTL 1006A2.5S</b>	10	6	2.381	10.65	8.1	2.5×1	2 830	4 810	0.10	20
<b>RNFTL 1208A2.5S</b>	12	8	2.778	12.65	9.6	2.5×1	3 730	6 560	0.10	25
<b>RNFTL 1404A3.5S</b>	14	4	2.778	14.5	11.5	3.5×1	5 370	10 800	0.10	25
<b>RNFTL 1405A2.5S</b>	14	5	3.175	14.5	11.0	2.5×1	5 260	9 720	0.10	30
<b>RNFTL 1610A2.5</b>	16	10	3.175	16.75	13.3	2.5×1	5 660	11 500	0.10	30
<b>RNFTL 1610A2.5S</b>	16	10	3.175	16.75	13.3	2.5×1	5 660	11 500	0.10	30
<b>RNFTL 1808A3.5</b>	18	8	4.762	18.5	13.6	3.5×1	13 200	25 800	0.15	34
<b>RNFTL 1808A3.5S</b>	18	8	4.762	18.5	13.6	3.5×1	13 200	25 800	0.15	34
<b>RNFTL 2005A2.5</b>	20	5	3.175	20.5	17.0	2.5×1	6 360	14 200	0.10	40
<b>RNFTL 2005A2.5S</b>	20	5	3.175	20.5	17.0	2.5×1	6 360	14 200	0.10	40
<b>RNFTL 2010A2.5</b>	20	10	4.762	21.25	16.2	2.5×1	10 900	21 800	0.15	40
<b>RNFTL 2010A2.5S</b>	20	10	4.762	21.25	16.2	2.5×1	10 900	21 800	0.15	40
<b>RNFTL 2505A5</b>	25	5	3.175	25.5	22.0	2.5×2	12 800	36 300	0.10	42
<b>RNFTL 2505A5S</b>	25	5	3.175	25.5	22.0	2.5×2	12 800	36 300	0.10	42
<b>RNFTL 2510A2.5</b>	25	10	6.35	26	19.0	2.5×1	17 500	35 200	0.20	44
<b>RNFTL 2510A2.5S</b>						2.5×1	17 500	35 200		44
<b>RNFTL 2510A5</b>						2.5×2	31 800	70 300		44
<b>RNFTL 2510A5S</b>						2.5×2	31 800	70 300		44

Notes: 1. Protruding portion of tube does not interfere with ball nut housing if its dimensions corresponding to U and V are large enough.  
 2. Actual screw shaft length may become slightly longer than nominal length L<sub>0</sub> due to manufacturing tolerance.  
 3. Only ball nut part numbers ending "S" are equipped with seals. External dimensions of those with seals are the same as those without.  
 In ball nut side view drawing, above the center line there is a seal, and beneath it there is no seal.  
 Seal for those with shaft diameter of 14 mm or less is made of synthetic resin. Seal for those of 16 mm or more is a "Brush" seal.

Ball nut dimensions											Nut Mass. (kg)	Arbor		Screw shaft			Shaft mass/m (kg)	Internal spatial volume of nut (cm <sup>3</sup> )	Standard volume of grease replenishing (cm <sup>3</sup> )	
Flange	Length		Bolt hole		Oil hole		Projecting tube			Outside dia.		Bore	Standard length		Screw shaft No.					
A	G	B	L <sub>n</sub>	W	X	Q	T	U	V	R	d <sub>o</sub>	d <sub>i</sub>	L <sub>0</sub>							
40	15	6	34	30	4.5	M3×0.5	3.0	15	15	7	0.092	8.1	6.1	400	800	-	RS1003A	0.50	-	-
40	15	6	36	30	4.5	M3×0.5	3.5	15	15	5	0.095	8.1	6.1	400	800	-	RS1006A	0.56	1.1	0.6
45	19	8	46	35	4.5	M3×0.5	5.5	19	18	7	0.18	9.6	7.6	400	800	-	RS1208A	0.74	1.8	0.9
50	19	10	43	40	4.5	M6×1	5.0	19	20	7	0.20	11.5	9.5	500	1 000	-	RS1404A	1.02	2.0	1.0
50	22	10	45	40	4.5	M6×1	5.0	22	21	8	0.26	11.0	9.0	500	1 000	-	RS1405A	1.00	2.4	1.2
53	23	10	54	41	5.5	M6×1	5.5	23	22.5	8	0.28	13.3	11.3	500	1 000	1 500	RS1610A	1.37	2.7	1.4
63	27	12	58	49	6.6	M6×1	6.0	27	27	8	0.43	13.6	11.6	500	1 000	1 500	RS1808A	1.60	5.2	2.6
60	28	10	46	50	4.5	M6×1	5.0	28	27	10	0.42	17.0	14.6	500	1 000	2 000	RS2005A	2.17	3.5	1.8
67	30	12	59	53	6.6	M6×1	6.0	30	29	12	0.55	16.2	13.8	500	1 000	2 000	RS2010A	2.18	7.1	3.6
71	28	12	66	57	6.6	M6×1	6.0	28	31	10	0.62	22.0	19.6	1 000	2 000	2 500	RS2505A	3.47	6.5	3.3
80	34	15	62	62	9	M6×1	7.5	34	37	17	0.75	19.0	16.6	1 000	2 000	2 500	RS2510A	13	6.5	
80	34	15	92	62	9	M6×1	7.5	34	37	17								18	9.0	

4. Nut assembly with arbor and screw shaft are separate at time of delivery.  
 5. Value obtained by dividing standard screw shaft length by 100 mm will be entered at end of the part number where marked with · · ·  
 6. Items in stock do not have surface treatment. For details of standard stock products, contact NSK.  
 7. Internal spatial volume of nut and volume of grease to be replenished are values for ball screws with seals. Recommended amount for replenishing is approximately 50% of nut's internal space. For ball screws without seals, apply grease to screw shaft surface or move ball nut by hand while filling them with grease so that grease permeates all areas. See page D16 for details.

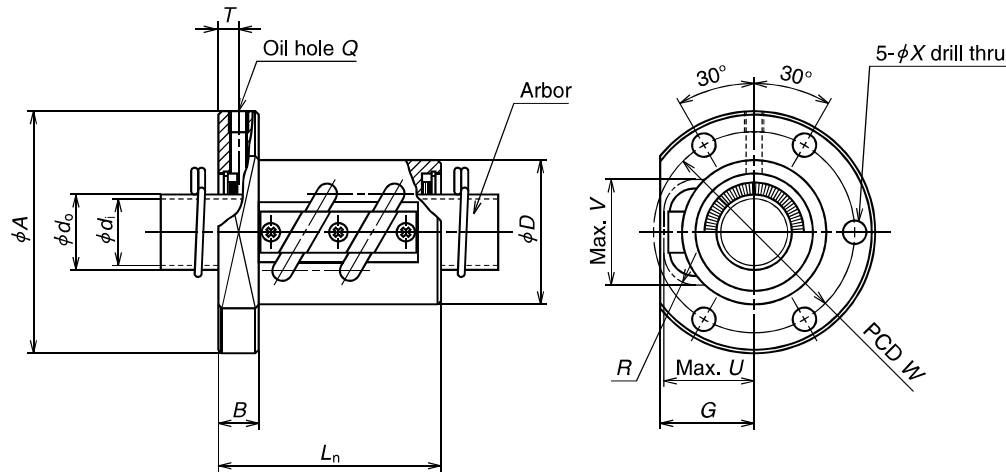

Ball nut No.	Shaft dia. <i>d</i>	Lead <i>l</i>	Ball dia. <i>D<sub>w</sub></i>	Ball circle dia. <i>d<sub>m</sub></i>	Root dia. <i>d<sub>r</sub></i>	Effective turns of balls Turns × Circuits	Basic load rating (N)		Axial play Max.	Ball nut dimensions Outside dia. <i>D</i>
							Dynamic <i>C<sub>a</sub></i>	Static <i>C<sub>0a</sub></i>		
<b>RNFTL 2806A2.5</b> <b>RNFTL 2806A2.5S</b>	28	6	3.175	28.5	25.0	2.5×1	7 430	20 300	0.10	50
<b>RNFTL 2806A5</b> <b>RNFTL 2806A5S</b>						2.5×2	13 500	40 600		
<b>RNFTL 3210A5</b> <b>RNFTL 3210A5S</b>	32	10	6.35	33.75	27.0	2.5×2	35 700	92 200	0.20	55
<b>RNFTL 3610A2.5</b> <b>RNFTL 3610A2.5S</b>	36	10	6.35	37	30.0	2.5×1	21 000	51 000	0.20	60
<b>RNFTL 3610A5</b> <b>RNFTL 3610A5S</b>						2.5×2	38 100	102 000		
<b>RNFTL 4010A7</b> <b>RNFTL 4010A7S</b>	40	10	6.35	41.75	35.0	3.5×2	53 500	164 000	0.20	65
<b>RNFTL 4512A5</b> <b>RNFTL 4512A5S</b>	45	12	7.144	46.5	39.0	2.5×2	49 600	147 000	0.23	70
<b>RNFTL 5010A7</b> <b>RNFTL 5010A7S</b>	50	10	6.35	51.75	45.0	3.5×2	59 500	205 000	0.20	80
<b>RNFTL 5016A5</b> <b>RNFTL 5016A5S</b>	50	16	9.525	52	42.0	2.5×2	99 900	293 000	0.23	85

Notes: 1. Protruding portion of tube does not interfere with ball nut housing if its dimensions corresponding to U and V are large enough.  
 2. Actual screw shaft length may become slightly longer than nominal length *L<sub>s</sub>*, due to manufacturing tolerance.  
 3. Only ball nut part numbers ending "S" are equipped with seals. External dimensions of those with seals are the same as those without.  
 In ball nut side view drawing, above the center line there is a seal, and beneath it there is no seal.  
 Seal for those with shaft diameter of 14 mm or less is made of synthetic resin. Seal for those of 16 mm or more is a "Brush" seal.

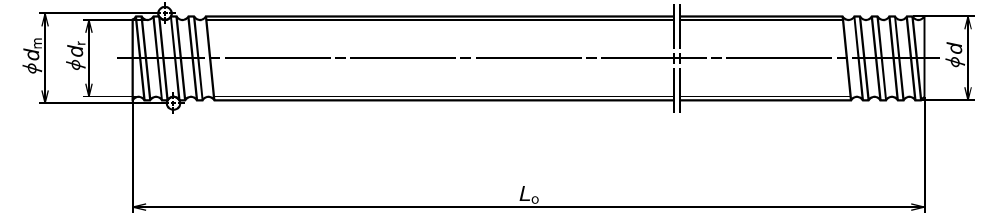

Unit: mm

Ball nut dimensions											Nut Mass. (kg)	Arbor		Screw shaft			Shaft mass/m (kg)	Internal spatial volume of nut (cm <sup>3</sup> )	Standard volume of grease replenishing (cm <sup>3</sup> )	
Flange		Length	Bolt hole		Oil hole			Projecting tube				Outside dia.	Bore	Standard length						Screw shaft No.
A	G	B	L <sub>n</sub>	W	X	Q	T	U	V	R	d <sub>0</sub>	d <sub>i</sub>	L <sub>0</sub>							
79	33	15	55	65	6.6	M6×1	7.5	33	34	10	0.85	25.0	22.6	1 000	2 000	2 500	RS2806A··	4.47	5.9	3.0
79	33	15	79	65	6.6	M6×1	7.5	33	34	10	1.07								8.4	4.2
97	39	18	97	75	11	M6×1	9.0	39	42	17	1.55	27.0	24.6	1 000	2 000	3 000	RS3210A··	5.53	29	15
102	42	18	68	80	11	M6×1	9.0	42	46	17	1.47	30.0	27.6	1 000	2 000	3 000	RS3610A··	6.91	21	11
102	42	18	98	80	11	M6×1	9.0	42	46	17	1.80								33	17
114	44	20	120	90	14	M6×1	10.0	44	50	20	2.49	35.0	31.8	2 000	3 000	4 000	RS4010A··	8.87	42	21
130	47	22	116	100	18	M6×1	11.0	47	55	20	3.07	39.0	35.8	2 000	3 000	4 000	RS4512A··	11.16	49	25
140	52	22	122	110	18	M6×1	11.0	52	59	20	4.06	45.0	41.8	2 000	3 000	4 000	RS5010A··	14.15	53	27
163	57	28	146	125	22	M6×1	14.0	57	63	25	6.42	42.0	38.8	2 000	3 000	4 000	RS5016A··	13.48	94	47

4. Nut assembly with arbor and screw shaft are separate at time of delivery.  
 5. Value obtained by diving standard screw shaft length by 100 mm will be entered at end of the part number where marked with ··.  
 6. Items in stock do not have surface treatment. For details of standard stock products, contact NSK.  
 7. Internal spatial volume of nut and volume of grease to be replenished are values for ball screws with seals. Recommended amount for replenishing is approximately 50% of nut's internal space. For ball screws without seals, apply grease to screw shaft surface or move ball nut by hand while filling them with grease so that grease permeates all areas. See page D16 for details.

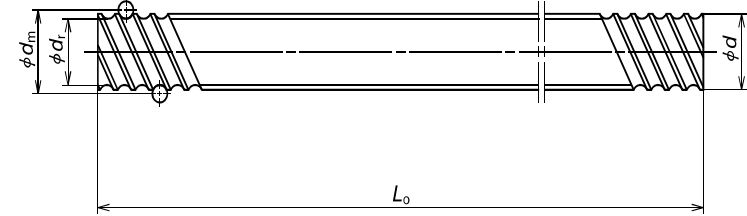
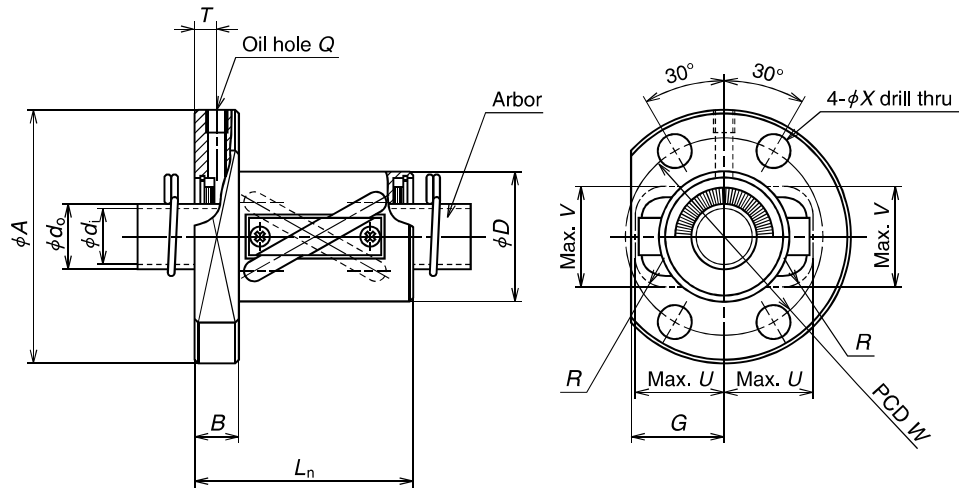

Ball nut No.	Shaft dia. <i>d</i>	Lead <i>l</i>	Ball dia. <i>D<sub>w</sub></i>	Ball circle dia. <i>d<sub>m</sub></i>	Root dia. <i>d<sub>r</sub></i>	Effective turns of balls × Circuits	Basic load rating (N)		Axial play Max.	Ball nut dimensions Outside dia. <i>D</i>
							Dynamic <i>C<sub>a</sub></i>	Static <i>C<sub>0a</sub></i>		
<b>RNFTL 1212A3</b>	12	12	2.381	12.65	10.1	1.5 × 2	3 360	6 270	0.10	24
<b>RNFTL 1616A3</b> <b>RNFTL 1616A3S</b>	16	16	2.778	16.65	13.6	1.5 × 2	4 880	9 650	0.10	30
<b>RNFTL 2020A3</b> <b>RNFTL 2020A3S</b>	20	20	3.175	20.75	17.3	1.5 × 2	7 010	15 400	0.10	35
<b>RNFTL 2525A3</b> <b>RNFTL 2525A3S</b>	25	25	3.969	26	22.0	1.5 × 2	10 500	24 100	0.12	45
<b>RNFTL 3232A3</b> <b>RNFTL 3232A3S</b>	32	32	4.762	33.25	28.0	1.5 × 2	15 300	37 100	0.15	55
<b>RNFTL 4040A3</b> <b>RNFTL 4040A3S</b>	40	40	6.35	41.75	35.0	1.5 × 2	24 400	61 600	0.20	70

Notes: 1. Protruding portion of tube does not interfere with ball nut housing if its dimensions corresponding to U and V are large enough.  
 2. Actual screw shaft length may become slightly longer than nominal length  $L_0$  due to manufacturing tolerance.  
 3. Only ball nut part numbers ending "S" are equipped with seals. External dimensions of those with seals are the same as those without.  
 In ball nut side view drawing, above the center line there is a seal, and beneath it there is no seal.  
 Seal for those with shaft diameter of 14 mm or less is made of synthetic resin. Seal for those of 16 mm or more is a "Brush" seal.

Ball nut dimensions											Nut Mass (kg)	Arbor		Screw shaft			Shaft mass/m (kg)	Internal spatial volume of nut (cm <sup>3</sup> )	Standard volume of grease replenishing (cm <sup>3</sup> )	
Flange		Length	Bolt hole	Oil hole	Projecting tube			Outside dia. <i>d<sub>o</sub></i>	Bore <i>d<sub>i</sub></i>	Standard length			Screw shaft No.							
A	G	<i>L<sub>n</sub></i>	W	X	Q	T	U			V		R		<i>L<sub>0</sub></i>						
44	17	8	44	34	4.5	M3×0.5	4.0	17	16	5	0.16	10.1	8.1	400	800	-	RS1212A··	0.74	1.7	0.9
55	22	10	50	43	6.6	M6×1	5.0	22	22	7	0.29	13.6	11.6	500	1 000	1 500	RS1616A··	1.37	2.8	1.4
68	25	12	59	52	9	M6×1	6.0	25	27	8	0.49	17.3	14.9	500	1 000	2 000	RS2020A··	2.19	4.9	2.5
80	31	12	69	63	9	M6×1	6.0	31	32	10	0.80	22.0	19.6	1 000	2 000	2 500	RS2525A··	3.43	9.1	4.6
100	37	15	84	80	11	M6×1	7.5	37	40	12	1.46	28.0	25.6	1 000	2 000	3 000	RS3232A··	5.71	19	9.5
120	46	18	103	95	14	M6×1	9.0	46	49	15	2.69	35.0	31.8	2 000	3 000	4 000	RS4040A··	8.82	39	20

4. Nut assembly with arbor and screw shaft are separate at time of delivery.  
 5. Value obtained by dividing standard screw shaft length by 100 mm will be entered at end of the part number where marked with ···.  
 6. Items in stock do not have surface treatment. For details of standard stock products, contact NSK.  
 7. Internal spatial volume of nut and volume of grease to be replenished are values for ball screws with seals. Recommended amount for replenishing is approximately 50% of nut's internal space. For ball screws without seals, apply grease to screw shaft surface or move ball nut by hand while filling them with grease so that grease permeates all areas. See page D16 for details.

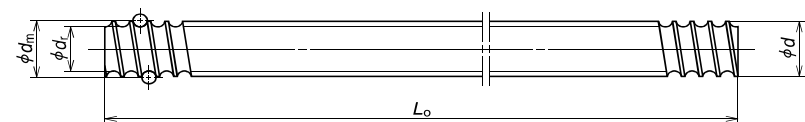
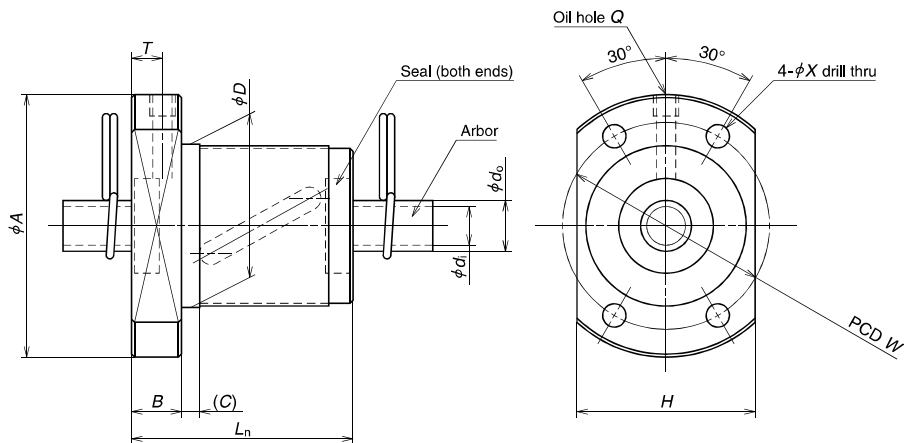

Ball nut No.	Shaft dia. <i>d</i>	Lead <i>l</i>	Ball dia. <i>D<sub>w</sub></i>	Ball circle dia. <i>d<sub>m</sub></i>	Root dia. <i>d</i>	Effective turns of balls Turns × Circuits	Basic load rating (N)		Axial play Max.	Ball nut dimensions Outside dia. <i>D</i>
							Dynamic <i>C<sub>a</sub></i>	Static <i>C<sub>0a</sub></i>		
							<b>RNFBL 1006A2.5S</b>	10		
<b>RNFBL 1208A2.5S</b>	12	8	2.778	12.65	9.6	2.5×1	3 730	6 560	0.10	29
<b>RNFBL 1404A3.5S</b>	14	4	2.778	14.5	11.5	3.5×1	5 370	10 800	0.10	31
<b>RNFBL 1405A2.5S</b>	14	5	3.175	14.5	11.0	2.5×1	5 260	9 720	0.10	32
<b>RNFBL 1808A3.5S</b>	18	8	4.762	18.5	13.6	3.5×1	13 200	25 800	0.15	50
<b>RNFBL 2005A2.5S</b>	20	5	3.175	20.5	17.0	2.5×1	6 360	14 200	0.10	40
<b>RNFBL 2010A2.5S</b>	20	10	4.762	21.25	16.2	2.5×1	10 900	21 800	0.15	52
<b>RNFBL 2505A2.5S</b>	25	5	3.175	25.5	22.0	2.5×1	7 070	18 200	0.10	43
<b>RNFBL 2505A5S</b>						2.5×2	12 800	36 300		
<b>RNFBL 2510A2.5S</b>	25	10	6.35	26	19.0	2.5×1	17 500	35 200	0.20	60
<b>RNFBL 2510A5S</b>						2.5×2	31 800	70 300		
<b>RNFBL 2806A2.5S</b>	28	6	3.175	28.5	25.0	2.5×1	7 430	20 300	0.10	50
<b>RNFBL 2806A5S</b>						2.5×2	13 500	40 600		
<b>RNFBL 3210A2.5S</b>	32	10	6.35	33.75	27.0	2.5×1	19 700	46 100	0.20	67
<b>RNFBL 3210A5S</b>						2.5×2	35 700	92 200		
<b>RNFBL 3610A2.5S</b>	36	10	6.35	37	30.0	2.5×1	21 000	51 000	0.20	70
<b>RNFBL 3610A5S</b>						2.5×2	38 100	102 000		
<b>RNFBL 4010A5S</b>	40	10	6.35	41.75	35.0	2.5×2	40 100	116 000	0.20	76

- Notes: 1. Actual screw shaft length may become slightly longer than nominal length  $L_0$  due to manufacturing tolerance.  
 2. Nut assembly with arbor and screw shaft are separate at time of delivery.  
 3. Value obtained by diving standard screw shaft length by 100 mm will be entered at end of the part number where marked with ...

Ball nut dimensions										Nut Mass. (kg)	Arbor		Screw shaft				Shaft mass/m (kg)	Internal spatial volume of nut (cm <sup>3</sup> )	Standard volume of grease re-lubricating (cm <sup>3</sup> )
Flange		Length		Bolt hole		Oil hole		Nut	Outside dia.		Bore	Standard length		Screw shaft No.					
A	H	B	Overal length <i>L<sub>m</sub></i>	(C)	W	X	Q		T		<i>d<sub>o</sub></i>	<i>d<sub>i</sub></i>	<i>L<sub>0</sub></i>						
42	29	8	36	3	34	4.5	M3×0.5	5.0	0.16	8.1	6.1	400	800	—	RS1006A··	0.56	1.1	0.6	
45	32	8	44	3	37	4.5	M3×0.5	5.5	0.21	9.6	7.6	400	800	—	RS1208A··	0.81	1.6	0.8	
50	37	10	40	4	40	4.5	M6×1	5.0	0.25	11.5	9.5	500	1 000	—	RS1404A··	1.02	2.4	1.2	
50	38	10	40	4	40	4.5	M6×1	5.0	0.26	11.0	9.0	500	1 000	—	RS1405A··	1.00	1.9	1.0	
80	60	12	61	4	65	6.6	M6×1	6.0	1.00	13.6	11.6	500	1 000	1 500	RS1808A··	1.60	5.8	2.9	
60	46	10	40	4	50	4.5	M6×1	5.0	0.37	17.0	14.6	500	1 000	2 000	RS2005A··	2.17	2.8	1.4	
82	64	12	61	5	67	6.6	M6×1	6.0	1.05	16.2	13.8	500	1 000	2 000	RS2010A··	2.18	7.6	3.8	
67	50	10	40	4	55	5.5	M6×1	5.0	0.40	22.0	19.6	1 000	2 000	2 500	RS2505A··	3.47	3.5	1.8	
			0.50						4.7								2.4		
96	72	15	66	5	78	9.0	M6×1	7.5	1.52	19.0	16.6	1 000	2 000	2 500	RS2510A··	3.13	14	7.0	
			1.99						19								9.5		
80	60	12	47	5	65	6.6	M6×1	6.0	0.70	25.0	22.6	1 000	2 000	2 500	RS2806A··	4.47	4.5	2.3	
			0.87						7.6								3.8		
103	78	15	67	5	85	9.0	M6×1	7.5	1.72	27.0	24.6	1 000	2 000	3 000	RS3210A··	5.53	20	10	
			2.25						28								14		
110	82	17	69	5	90	11.0	M6×1	8.5	1.97	30.0	27.6	1 000	2 000	3 000	RS3610A··	6.91	21	11	
			2.53						29								15		
116	88	17	99	5	96	11.0	M6×1	8.5	2.86	35.0	31.8	2 000	3 000	4 000	RS4010A··	8.87	36	18	

4. Items in stock do not have surface treatment. For details of standard stock products, contact NSK.  
 5. Seal for those with shaft diameter of 14 mm or less is made of synthetic resin. Seal for those of 16 mm or more is a "Brush" seal.  
 6. Recommended quantity of grease is about 50% of ball nut's internal space. See page D16 for details.



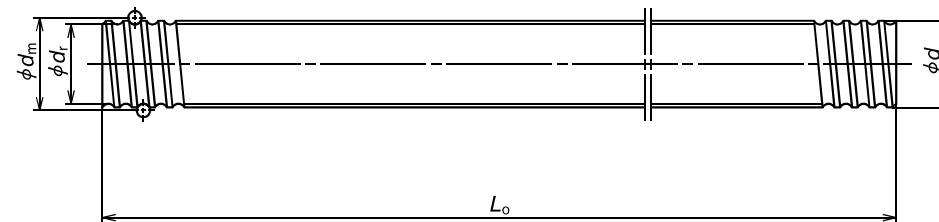
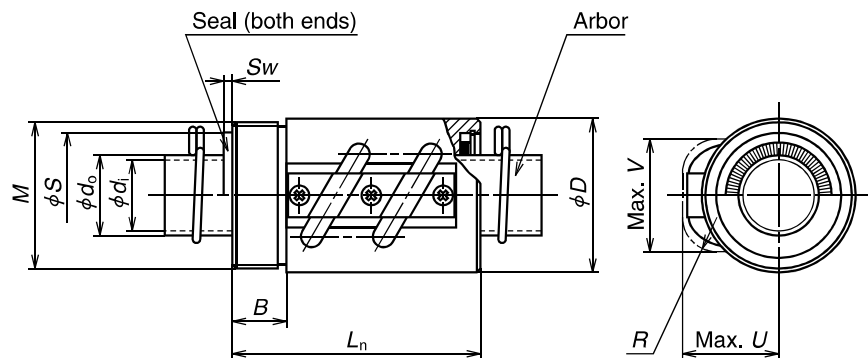

Unit: mm

Ball nut No.	Shaft dia. <i>d</i>	Lead <i>l</i>	Ball dia. <i>D<sub>w</sub></i>	Ball circle dia. <i>d<sub>m</sub></i>	Root dia. <i>d<sub>r</sub></i>	Effective turns of balls × Circuits	Basic load rating (N)		Axial play Max.	Ball nut dimensions	
							Dynamic <i>C<sub>d</sub></i>	Static <i>C<sub>s</sub></i>		Outside dia. <i>D</i>	
<b>RNCT 1003A3.5</b>	10	3	2.381	10.65	8.1	3.5 × 1	3 780	6 730	0.10	20	
<b>RNCT 1404A3.5S</b>	14	4	2.778	14.5	11.5	3.5 × 1	5 370	10 800	0.10	25	
<b>RNCT 1405A2.5S</b>	14	5	3.175	14.5	11.0	2.5 × 1	5 260	9 720	0.10	30	
<b>RNCT 1808A3.5</b>	18	8	4.762	18.5	13.6	3.5 × 1	13 200	25 800	0.15	34	
<b>RNCT 2005A2.5</b>	20	5	3.175	20.5	17.0	2.5 × 1	6 360	14 200	0.10	40	
<b>RNCT 2005A2.5S</b>	20	5	3.175	20.5	17.0	2.5 × 1	6 360	14 200	0.10	40	
<b>RNCT 2505A5</b>	25	5	3.175	25.5	22.0	2.5 × 2	12 800	36 300	0.10	42	
<b>RNCT 2505A5S</b>	25	5	3.175	25.5	22.0	2.5 × 2	12 800	36 300	0.10	42	
<b>RNCT 2510A5</b>	25	10	6.35	26	19.0	2.5 × 2	31 800	70 300	0.20	44	
<b>RNCT 2510A5S</b>	25	10	6.35	26	19.0	2.5 × 2	31 800	70 300	0.20	44	
<b>RNCT 2806A5</b>	28	6	3.175	28.5	25.0	2.5 × 2	13 500	40 600	0.10	50	
<b>RNCT 2806A5S</b>	28	6	3.175	28.5	25.0	2.5 × 2	13 500	40 600	0.10	50	
<b>RNCT 3210A5</b>	32	10	6.35	33.75	27.0	2.5 × 2	35 700	92 200	0.20	55	
<b>RNCT 3210A5S</b>	32	10	6.35	33.75	27.0	2.5 × 2	35 700	92 200	0.20	55	
<b>RNCT 3610A5</b>	36	10	6.35	37	30.0	2.5 × 2	38 100	102 000	0.20	60	
<b>RNCT 3610A5S</b>	36	10	6.35	37	30.0	2.5 × 2	38 100	102 000	0.20	60	
<b>RNCT 4010A7</b>	40	10	6.35	41.75	35.0	3.5 × 2	53 500	164 000	0.20	65	
<b>RNCT 4010A7S</b>	40	10	6.35	41.75	35.0	3.5 × 2	53 500	164 000	0.20	65	
<b>RNCT 4512A5</b>	45	12	7.144	46.5	39.0	2.5 × 2	49 600	147 000	0.23	70	
<b>RNCT 4512A5S</b>	45	12	7.144	46.5	39.0	2.5 × 2	49 600	147 000	0.23	70	
<b>RNCT 5010A7</b>	50	10	6.35	51.75	45.0	3.5 × 2	59 500	205 000	0.20	80	
<b>RNCT 5010A7S</b>	50	10	6.35	51.75	45.0	3.5 × 2	59 500	205 000	0.20	80	
<b>RNCT 5016A5</b>	50	16	9.525	52	42.0	2.5 × 2	99 900	293 000	0.23	85	
<b>RNCT 5016A5S</b>	50	16	9.525	52	42.0	2.5 × 2	99 900	293 000	0.23	85	

Notes: 1. Protruding portion of tube does not interfere with ball nut housing if its dimensions corresponding to U and V are large enough.  
 2. Actual screw shaft length may become slightly longer than nominal length  $L_0$  due to manufacturing tolerance.  
 3. Only ball nut part numbers ending "S" are equipped with seals. External dimensions of those with seals are the same as those without.  
 In ball nut side view drawing, above the center line there is a seal, and beneath it there is no seal.  
 Seal for those with shaft diameter of 14 mm or less is made of synthetic resin. Seal for those of 16 mm or more is a "Brush" seal.

Ball nut dimensions						Nut Mass. (kg)	Seal dimensions		Arbor		Screw shaft			Shaft mass/m (kg)	Internal spatial volume of nut (cm <sup>3</sup> )	Standard volume of grease replenishing (cm <sup>3</sup> )	
V-thread		Length	Projecting tube				Diameter	Thickness	Outside dia.	Bore	Standard length						Screw shaft No.
<i>M</i>	<i>B</i>		<i>U</i>	<i>V</i>	<i>R</i>						<i>L<sub>0</sub></i>	<i>L<sub>1</sub></i>	<i>L<sub>2</sub></i>				
M18 × 1	10	38	15	15	7	0.049	-	-	8.1	6.1	400	800	-	RS1003A	0.50	-	-
M24 × 1	10	43	19	20	7	0.083	-	-	11.5	9.5	500	1 000	-	RS1404A	1.02	2.7	1.4
M26 × 1.5	10	45	22	21	8	0.15	-	-	11.0	9.0	500	1 000	-	RS1405A	1.00	3.1	1.6
M32 × 1.5	12	58	27	27	8	0.21	28.5	2.5	13.6	11.6	500	1 000	1 500	RS1808A	1.60	6.6	3.3
M36 × 1.5	12	48	28	27	10	0.28	29.5	2.5	17.0	14.6	500	1 000	2 000	RS2005A	2.17	4.8	2.4
M40 × 1.5	15	69	28	31	10	0.38	34.5	2.5	22.0	19.6	1 000	2 000	2 500	RS2505A	3.47	8.4	4.2
M42 × 1.5	15	92	34	37	17	0.49	38.5	2.5	19.0	16.6	1 000	2 000	2 500	RS2510A	3.13	21	1
M45 × 1.5	15	79	33	34	10	0.68	37.5	2.5	25.0	22.6	1 000	2 000	2 500	RS2806A	4.47	9.7	4.9
M50 × 1.5	18	97	39	42	17	0.79	45.5	2.5	27.0	24.6	1 000	2 000	3 000	RS3210A	5.53	32	16
M55 × 2	18	98	42	46	17	0.97	50.5	3.0	30.0	27.6	1 000	2 000	3 000	RS3610A	6.91	32	16
M60 × 2	25	125	44	50	20	1.37	54.5	3.0	35.0	31.8	2 000	3 000	4 000	RS4010A	8.87	51	26
M65 × 2	30	124	47	55	20	1.42	60.5	3.0	39.0	35.8	2 000	3 000	4 000	RS4512A	11.16	60	30
M75 × 2	40	140	52	59	20	2.41	64.5	3.0	45.0	41.8	2 000	3 000	4 000	RS5010A	14.15	76	38
M80 × 2	40	158	57	63	25	3.14	68.5	3.0	42.0	38.8	2 000	3 000	4 000	RS5016A	13.48	114	57

4. Nut assembly with arbor and screw shaft are separate at time of delivery.  
 5. Value obtained by dividing standard screw shaft length by 100 mm will be entered at end of the part number where marked with · · ·  
 6. Items in stock do not have surface treatment. For details of standard stock products, contact NSK.  
 7. Internal spatial volume of nut and volume of grease to be replenished are values for ball screws with seals. Recommended amount for replenishing is approximately 50% of nut's internal space. For ball screws without seals, apply grease to screw shaft surface or move ball nut by hand while filling them with grease so that grease permeates all areas. See page D16 for details.

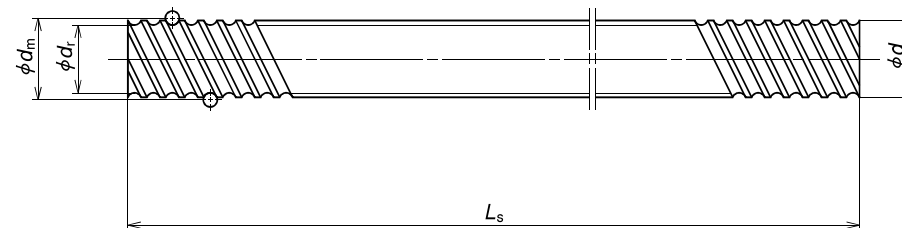
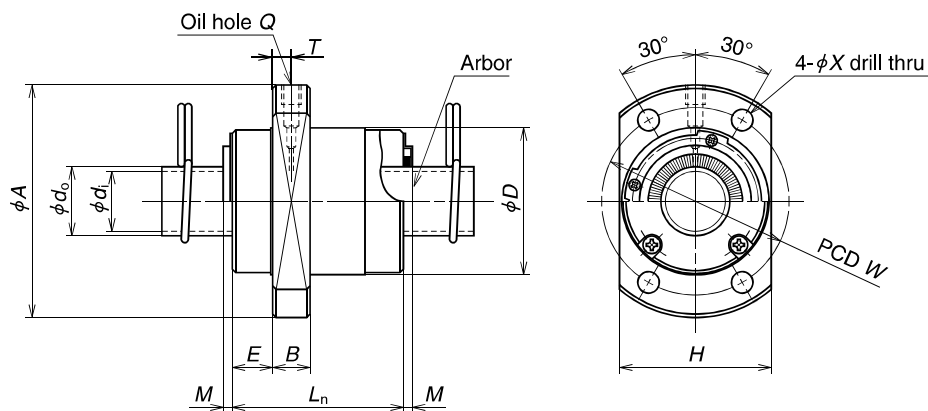

Unit: mm

Ball nut No.	Shaft dia. <i>d</i>	Lead <i>l</i>	Ball dia. <i>D<sub>w</sub></i>	Ball circle dia. <i>d<sub>m</sub></i>	Root dia. <i>d<sub>r</sub></i>	Effective turns of balls × Circuits	Basic load rating (N)		Axial play Max.	Ball nut dimensions Outside dia. <i>D</i>
							Dynamic <i>C<sub>d</sub></i>	Static <i>C<sub>s</sub></i>		
<b>RNFCL 1212A3</b> <b>RNFCL 1212A6</b>	12	12	2.381	12.65	10.1	1.7 × 2 1.7 × 4	3 740 6 780	6 640 13 300	0.10	26
<b>RNFCL 1520A3</b> <b>RNFCL 1520A6S</b>	15	20	3.175	15.5	12.2	1.7 × 2	6 730	12 300	0.10	33
<b>RNFCL 1616A3</b> <b>RNFCL 1616A3S</b> <b>RNFCL 1616A6</b> <b>RNFCL 1616A6S</b>	16	16	2.778	16.65	13.5	1.7 × 2 1.7 × 4	5 430 9 860	10 400 20 800	0.10	32
<b>RNFCL 2020A3</b> <b>RNFCL 2020A3S</b> <b>RNFCL 2020A6</b> <b>RNFCL 2020A6S</b>	20	20	3.175	20.75	17.3	1.7 × 2 1.7 × 4	7 810 14 200	16 500 33 000	0.10	39
<b>RNFCL 2525A3</b> <b>RNFCL 2525A3S</b> <b>RNFCL 2525A6</b> <b>RNFCL 2525A6S</b>	25	25	3.969	26	22.0	1.7 × 2 1.7 × 4	11 700 21 200	25 800 51 500	0.12	47
<b>RNFCL 3232A3</b> <b>RNFCL 3232A3S</b> <b>RNFCL 3232A6</b> <b>RNFCL 3232A6S</b>	32	32	4.762	33.25	28.0	1.7 × 2 1.7 × 4	17 100 31 000	40 500 81 000	0.15	58
<b>RNFCL 4040A3</b> <b>RNFCL 4040A3S</b> <b>RNFCL 4040A6</b> <b>RNFCL 4040A6S</b>	40	40	6.35	41.75	35.0	1.7 × 2 1.7 × 4	27 200 49 300	67 900 136 000	0.20	73
<b>RNFCL 5050A3</b> <b>RNFCL 5050A3S</b> <b>RNFCL 5050A6</b> <b>RNFCL 5050A6S</b>	50	50	7.938	52.25	44.0	1.7 × 2 1.7 × 4	40 600 73 700	106 000 212 000	0.25	90

- Notes: 1. Actual screw shaft length may become slightly longer than nominal length  $L_s$  due to manufacturing tolerance.  
 2. Nut assembly with arbor and screw shaft are separate at time of delivery.  
 3. Value obtained by dividing the standard screw shaft length by 100 mm will be entered at end of the part number where marked with ...  
 4. Items in stock do not have surface treatment. For details of standard stock products, contact NSK.  
 5. Length of nut becomes longer (2 × M) for those with "brush" seals.

Ball nut dimensions										Nut Mass. (kg)	Arbor		Screw shaft			Shaft mass/m (kg)	Internal spatial volume of nut (cm <sup>3</sup> )	Standard volume of grease replenishing (cm <sup>3</sup> )	
Flange		Length			Bolt hole		Oil hole		Outside dia. <i>d<sub>b</sub></i>		Bore <i>d<sub>i</sub></i>	Standard length			Screw shaft No.				
<i>A</i>	<i>H</i>	<i>B</i>	<i>E</i>	<i>L<sub>n</sub></i>	<i>M</i>	<i>W</i>	<i>X</i>	<i>Q</i>		<i>T</i>		<i>L<sub>s</sub></i>							
44	28	6	9	30	—	35	4.5	M3 × 0.5	3.0	0.12	10.1	8.1	400	800	—	RS1212A...	0.74	—	—
51	35	10	11	45	3	42	4.5	M6 × 1	5.0	0.28	12.2	10.2	500	1 000	1 500	RS1520A...	1.15	3.3	1.7
53	34	10	10	38	3	42	4.5	M6 × 1	5.0	0.23	13.5	11.5	500	1 000	1 500	RS1616A...	1.37	2.6	1.3
62	41	10	11.5	46	3	50	5.5	M6 × 1	5.0	0.37	17.3	14.9	500	1 000	2 000	RS2020A...	2.19	4.4	2.2
74	49	12	13	55	3	60	6.6	M6 × 1	6.0	0.62	22.0	19.6	1 000	2 000	2 500	RS2525A...	3.43	8.2	4.1
92	60	12	16	70	3	74	9	M6 × 1	5.5	1.10	28.0	25.6	1 000	2 000	3 000	RS3232A...	5.71	16	8.0
114	75	15	19.5	85	3.5	93	11	M6 × 1	6.5	2.09	35.0	31.8	2 000	3 000	4 000	RS4040A...	8.82	32	16
135	92	20	21.5	107	3.5	112	14	M6 × 1	7.0	3.90	44.0	40.8	2 000	3 000	4 000	RS5050A...	13.81	64	32
					3.5												68	34	

6. Internal spatial volume of nut and volume of grease to be replenished are values for ball screws with seals. Recommended amount for replenishing is approximately 50% of nut's internal space. For ball screws without seals, apply grease to screw shaft surface or move ball nut by hand while filling them with grease so that grease permeates all areas. See page D16 for details.

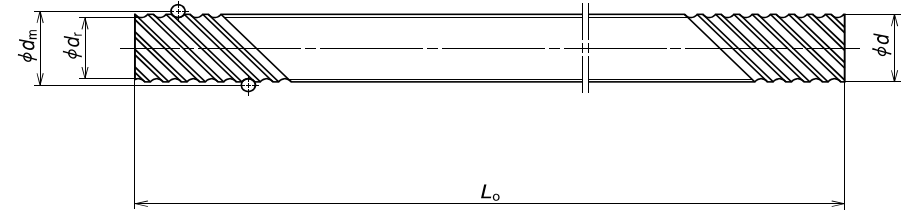
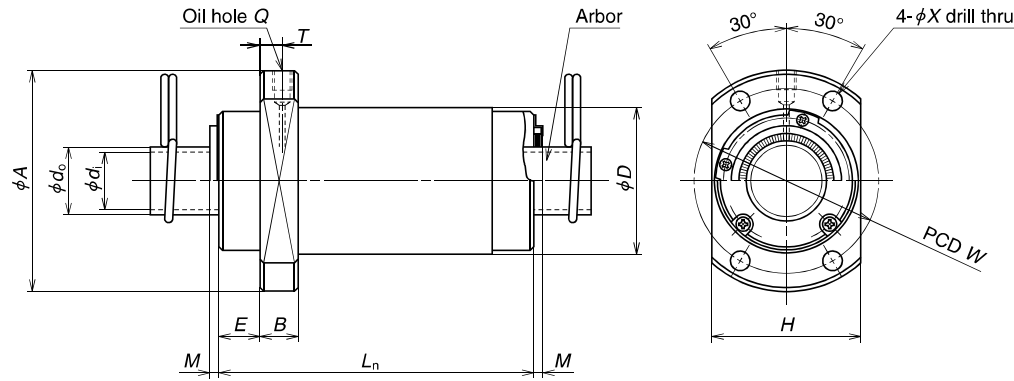

Unit: mm

Ball nut No.	Shaft dia. <i>d</i>	Lead <i>l</i>	Ball dia. <i>D<sub>w</sub></i>	Ball circle dia. <i>d<sub>m</sub></i>	Root dia. <i>d</i>	Effective turns of balls Turns × Circuits	Basic load rating (N)		Axial play Max.	Ball nut dimensions	
							Dynamic <i>C<sub>d</sub></i>	Static <i>C<sub>s</sub></i>		Outside dia. <i>D</i>	
<b>RNFCL 1632A2</b> <b>RNFCL 1632A2S</b>	16	32	2.778	16.65	13.5	0.7 × 4	4 600	8 460	0.10	32	
<b>RNFCL 1632A3</b> <b>RNFCL 1632A3S</b>						1.7 × 2	5 430	10 400			
<b>RNFCL 1632A6</b> <b>RNFCL 1632A6S</b>						1.7 × 4	9 860	20 800			
<b>RNFCL 2040A2</b> <b>RNFCL 2040A2S</b>	20	40	3.175	20.75	17.3	0.7 × 4	6 610	13 600	0.10	38	
<b>RNFCL 2040A3</b> <b>RNFCL 2040A3S</b>						1.7 × 2	7 810	16 500			
<b>RNFCL 2040A6</b> <b>RNFCL 2040A6S</b>						1.7 × 4	14 200	33 000			
<b>RNFCL 2550A2</b> <b>RNFCL 2550A2S</b>	25	50	3.969	26	22.0	0.7 × 4	9 870	21 200	0.12	46	
<b>RNFCL 2550A3</b> <b>RNFCL 2550A3S</b>						1.7 × 2	11 700	25 800			
<b>RNFCL 2550A6</b> <b>RNFCL 2550A6S</b>						1.7 × 4	21 200	51 500			
<b>RNFCL 3264A3</b> <b>RNFCL 3264A3S</b>	32	64	4.762	33.25	28.0	1.7 × 2	17 100	40 500	0.15	58	
<b>RNFCL 3264A6</b> <b>RNFCL 3264A6S</b>						1.7 × 4	31 000	81 000			
<b>RNFCL 4080A3</b> <b>RNFCL 4080A3S</b>	40	80	6.350	41.75	35.0	1.7 × 2	27 200	67 900	0.20	73	
<b>RNFCL 4080A6</b> <b>RNFCL 4080A6S</b>						1.7 × 4	49 300	136 000			

Ball nut dimensions											Nut Mass. (kg)	Arbor		Screw shaft				Shaft mass/m (kg)	Internal spatial volume of nut (cm <sup>3</sup> )	Standard volume of grease replenishing (cm <sup>3</sup> )
Flange		Length			Bolt hole		Oil hole		Outside dia. <i>d<sub>e</sub></i>	Bore <i>d<sub>i</sub></i>		Standard length			Screw shaft No.					
<i>A</i>	<i>H</i>	<i>B</i>	<i>E</i>	<i>L<sub>n</sub></i>	<i>M</i>	<i>W</i>	<i>X</i>	<i>Q</i>				<i>T</i>	<i>L<sub>o</sub></i>							
50	34	10	10	34	—	41	4.5	M6 × 1	5.5	0.21	13.5	11.5	500	1 000	1 500	—	RS1632A·	1.34	2.4	1.2
				66	—					0.33									3.9	2.0
				66	3					0.33									4.1	2.1
58	40	10	11	41	—	48	5.5	M6 × 1	5.5	0.31	17.3	14.9	500	1 000	1 500	2 000	RS2040A·	2.15	4.1	2.1
				81	—					0.53									6.3	3.2
				81	3					0.53									7.0	3.5
70	48	12	13	50	—	58	6.6	M6 × 1	7.0	0.53	22.0	19.6	1 000	2 000	2 500	—	RS2550A·	3.37	8.4	4.2
				100	—					0.91									14	7.0
				100	3					0.91									15	7.5
92	60	12	15.5	126	—	74	9	M6 × 1	7.5	1.76	28.0	25.6	1 000	2 000	3 000	4 000	RS3264A·	5.63	24	12
				126	3					—									26	13
				126	3					—									—	—
114	75	15	19	158	—	93	11	M6 × 1	10.0	3.44	35.0	31.8	2 000	3 000	4 000	5 000	RS4080A·	8.69	52	26
				158	3.5					—									55	28
				158	3.5					—									—	—

- Actual screw shaft length may become slightly longer than nominal length *L<sub>n</sub>*, due to manufacturing tolerance.
- Nut assembly with arbor and screw shaft are separate at time of delivery.
- Value obtained by dividing the standard screw shaft length by 100 mm will be entered at end of the part number where marked with ··.
- Items in stock do not have surface treatment. For details of standard stock products, contact NSK.
- Length of nut becomes longer (2 × *M*) for those with "brush" seals.

- Internal spatial volume of nut and volume of grease to be replenished are values for ball screws with seals. Recommended amount for replenishing is approximately 50% of nut's internal space. For ball screws without seals, apply grease to screw shaft surface or move ball nut by hand while filling them with grease so that grease permeates all areas. See page D16 for details.

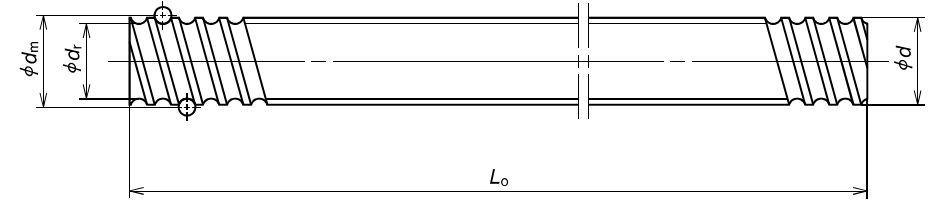
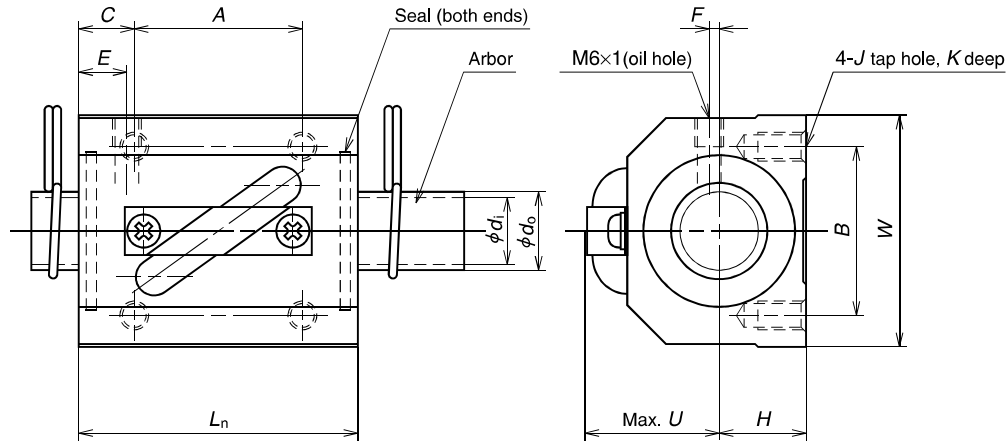

Ball nut No.	Shaft dia. <i>d</i>	Lead <i>l</i>	Ball dia. <i>D<sub>w</sub></i>	Ball circle dia. <i>d<sub>m</sub></i>	Root dia. <i>d<sub>r</sub></i>	Effective turns of balls × Circuits	Basic load rating (N)		Axial play Max.	Ball nut dimensions Length <i>L<sub>n</sub></i>
							Dynamic <i>C<sub>d</sub></i>	Static <i>C<sub>st</sub></i>		
							<b>RNSTL 1404A3.5S</b>	14		
<b>RNSTL 1405A2.5S</b>	14	5	3.175	14.5	11.0	2.5 × 1	5 260	9 720	0.10	38
<b>RNSTL 1808A3.5S</b>	18	8	4.762	18.5	13.6	3.5 × 1	13 200	25 800	0.15	56
<b>RNSTL 2005A2.5S</b>	20	5	3.175	20.5	17.0	2.5 × 1	6 360	14 200	0.10	38
<b>RNSTL 2010A2.5S</b>	20	10	4.762	21.25	16.2	2.5 × 1	10 900	21 800	0.15	58
<b>RNSTL 2505A2.5S</b>	25	5	3.175	25.5	22.0	2.5 × 1	7 070	18 200	0.10	35
<b>RNSTL 2510A5S</b>	25	10	6.35	26	19.0	2.5 × 2	31 800	70 300	0.20	94
<b>RNSTL 2806A2.5S</b>	28	6	3.175	28.5	25.0	2.5 × 1	7 430	20 300	0.10	42
<b>RNSTL 2806A5S</b>						2.5 × 2	13 500	40 600		67
<b>RNSTL 3210A2.5S</b>	32	10	6.35	33.75	27.0	2.5 × 1	19 700	46 100	0.20	64
<b>RNSTL 3210A5S</b>						2.5 × 2	35 700	92 200		94
<b>RNSTL 3610A2.5S</b>	36	10	6.35	37	30.0	2.5 × 1	21 000	51 000	0.20	64
<b>RNSTL 3610A5S</b>						2.5 × 2	38 100	102 000		96
<b>RNSTL 4512A5S</b>	45	12	7.144	46.5	39.0	2.5 × 2	49 600	147 000	0.23	115

Ball nut dimensions											Nut Mass. (kg)	Arbor		Screw shaft				Shaft mass/m (kg)	Internal spatial volume of nut (cm <sup>3</sup> )	Standard volume of grease re-lubricating (cm <sup>3</sup> )
Width	Center height	Bolt hole					Oil hole			Nut Mass. (kg)		Outside dia. <i>d<sub>o</sub></i>	Bore <i>d<sub>i</sub></i>	Standard length		Screw shaft No.				
		<i>W</i>	<i>H</i>	<i>A</i>	<i>B</i>	<i>C</i>	<i>J</i>	<i>K</i>	<i>E</i>					<i>F</i>	<i>U</i>		<i>L<sub>s</sub></i>			
34	13	22	26	8	M4	7	7	3	20	0.20	11.5	9.5	500	1 000	—	RS1404A··	1.02	1.6	0.8	
34	13	22	26	8	M4	7	7	3	21	0.20	11.0	9.0	500	1 000	—	RS1405A··	1.00	1.8	0.9	
48	17	35	35	10.5	M6	10	8	3	26	0.31	13.6	11.6	500	1 000	1 500	RS1808A··	1.60	3.4	1.7	
48	17	22	35	8	M6	9	6	2	27	0.24	17.0	14.6	500	1 000	2 000	RS2005A··	2.17	2.5	1.3	
48	18	35	35	11.5	M6	10	10	2	28	0.35	16.2	13.8	500	1 000	2 000	RS2010A··	2.18	6.3	3.2	
60	20	22	40	6.5	M8	10	6	0	27	0.31	22.0	19.6	1 000	2 000	2 500	RS2505A··	3.47	2.6	1.3	
60	23	60	40	17	M8	12	10	0	32	1.32	19.0	16.6	1 000	2 000	2 500	RS2510A··	3.13	18	9.0	
60	22	18	40	12	M8	12	8	0	32	0.65	25.0	22.6	1 000	2 000	2 500	RS2806A··	4.47	3.5	1.8	
60	22	40	40	13.5						1.04								7.0	3.5	
70	26	45	50	9.5	M8	12	10	0	38	1.12	27.0	24.6	1 000	2 000	3 000	RS3210A··	5.53	18	9.0	
70	26	60	50	17						1.75								27	14	
86	29	45	60	9.5	M10	16	11	0	41	1.76	30.0	27.6	1 000	2 000	3 000	RS3610A··	6.91	18	9.0	
86	29	60	60	18						2.64								27	14	
100	36	75	75	20	M12	20	13	0	46	1.22	39.0	35.8	2 000	3 000	4 000	RS4512A··	11.16	47	24	

Notes: 1. Actual screw shaft length may become slightly longer than nominal length *L<sub>s</sub>* due to manufacturing tolerance.  
 2. Nut assembly with arbor and screw shaft are separate at time of delivery.  
 3. Value obtained by dividing the standard screw shaft length by 100 mm will be entered at end of the part number where marked with ···

4. Items in stock do not have surface treatment. For details of standard stock products, contact NSK.  
 5. Seal for those with shaft diameter of 14 mm or less is made of synthetic resin. Seal for those of 16 mm or more is a "Brush" seal.  
 6. Recommended quantity of grease is about 50% of ball nut's internal space. See page D16 for details.