

A-5-2.5 Miniature LH Series

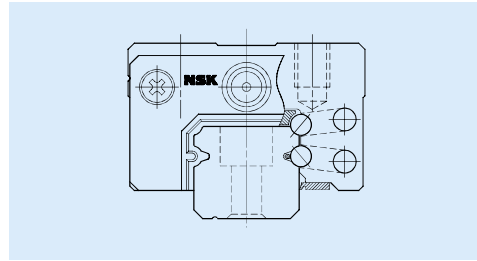
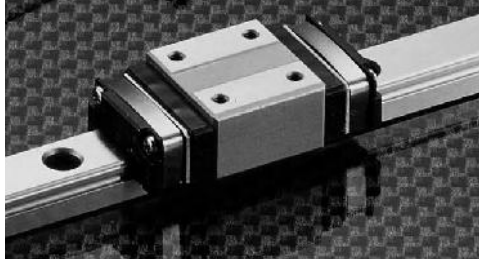

Fig. 1 LH Series

1. Features

(1) High self-aligning capability (rolling direction)

Same as the DF combination in angular contact bearings, self-aligning capability is high because the cross point of the contact lines of balls and grooves comes inside, and thus reducing moment rigidity.

This increases the capacity to absorb errors in installation.

(2) High load carrying capacity to vertical direction

The contact angle is set at 50 degrees, and thus increasing load carrying capacity as well as rigidity in vertical direction.

(3) High resistance against impact load

The bottom ball groove is formed in Gothic arch and the center of the top and bottom grooves are offset as shown in Fig. 2. The vertical load is generally carried by the top ball rows, where balls are contacting at two points. Because of this design, the bottom ball rows will carry load when a large impact load is applied vertically as shown in Fig. 3. This assures high resistance to the impact load.

(4) High accuracy

As showing in Fig. 4, fixing the master rollers to the ball grooves is easy thanks to the Gothic arch groove. This makes easy and accurate measuring of ball grooves.

(5) High corrosion resistance

High corrosion-resistant martensite stainless steel is incorporated as a standard feature to provides excellent corrosion resistance.

(6) Easy to handle

Safety design includes a retainer that prevents steel balls from dropping out of the ball slide even when the slide is removed from the rail. (LH10-12)

(7) Long-term maintenance-free

Superb features of NSK K1 Lubrication unit realize a long-term, maintenance-free operation.

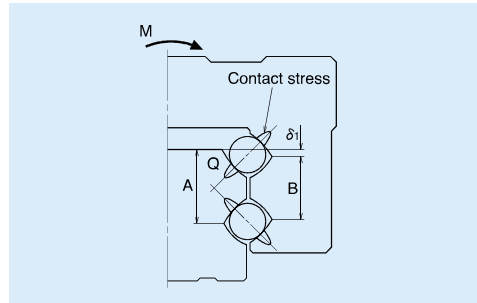

Fig. 2 Enlarged illustration of the offset Gothic arch groove

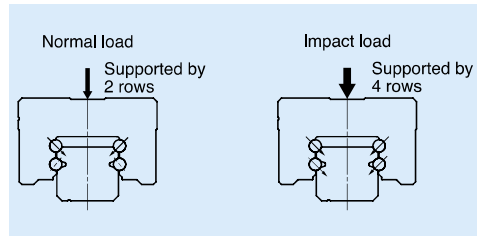

Fig. 3 When load is applied

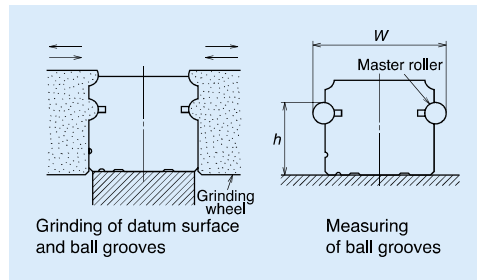
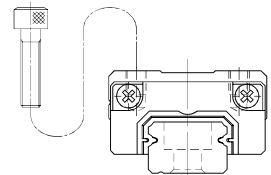
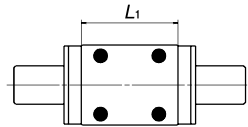

Fig. 4 Rail grinding and measuring

2. Ball slide shape

Ball slide Model	Shape/installation method	Type
AN		AN 

3. Accuracy and preload

(1) Running parallelism of ball slide

Table 1

Unit: μm

Rail length (mm) over or less	Preloaded assembly			
	Super precision P4	High precision P5	Precision grade P6	Normal grade PN
- 50	2	2	4.5	6
50 - 80	2	3	5	6
80 - 125	2	3.5	5.5	6.5
125 - 200	2	4	6	7
200 - 250	2.5	5	7	8
250 - 315	2.5	5	8	9
315 - 400	3	6	9	11
400 - 500	3	6	10	12
500 - 630	3.5	7	12	14
630 - 800	4.5	8	14	16

(2) Accuracy standard

The preloaded assembly has four accuracy grades; Super precision P4, High precision P5, Precision P6 and Normal PN grades.

• Tolerance of preloaded assembly

Table 2

Unit: μm

Characteristics	Accuracy grade	Super precision P4	High precision P5	Precision grade P6	Normal grade PN
Mounting height H		± 10	± 20	± 40	± 80
Variation of H (All ball slides on a set of rails)		3	5	7	15
Mounting width W_2 or W_3		± 10	± 15	± 25	± 50
Variation of W_2 or W_3 (All ball slides on reference rail)		5	7	10	20
Running parallelism of surface C to surface A Running parallelism of surface D to surface B		Shown in Table 1, Fig. 5			

(3) Combinations of accuracy and preload

Table 3

		Accuracy grade			
		Super precision	High precision	Precision grade	Normal grade
Without NSK K1 lubrication unit		P4	P5	P6	PN
With NSK K1 lubrication unit		K4	K5	K6	KN
With NSK K1 for food and medical equipment		F4	F5	F6	FN
Preload	Fine clearance Z0	○	○	○	○
	Slight preload Z1	○	○	○	○

(4) Assembled accuracy

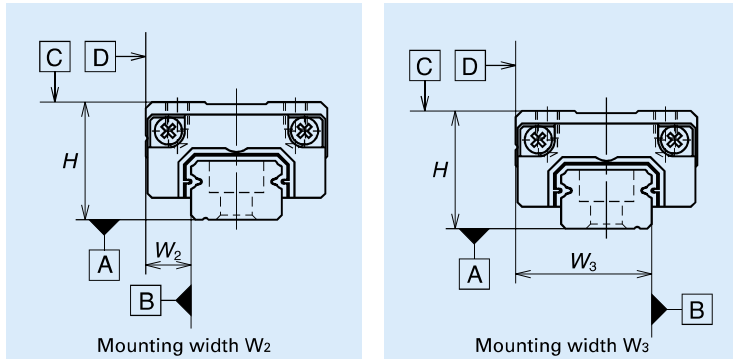

Fig. 5

(5) Preload and rigidity

We offer two levels of preload: Slight preload Z1 and Fine clearance Z0.

• Preload and rigidity of preloaded assembly

Table 4

Model No.	Preload (N)	Rigidity (N/μm)	
		Vertical direction	Lateral direction
		Slight preload Z1	Slight preload Z1
LH08AN	5	33	23
LH10AN	9	44	31
LH12AN	22	68	47

Note: Clearance for Fine clearance Z0 is 0 to 3μm. Therefore, preload is zero. However, Z0 of PN grade is 0 to 5μm.

4. Maximum rail length

Table 5 shows the limitations of rail length (maximum length). However, the limitations vary by accuracy grades.

Table 5 Length limitations of rails

Unit: mm

Series	Material	Size		
		08	10	12
LH	Stainless steel	375	600	800

Note: Rails can be butted if user requirement exceeds the rail length shown in the table. Please consult NSK.

5. Installation

(1) Permissible values of mounting error

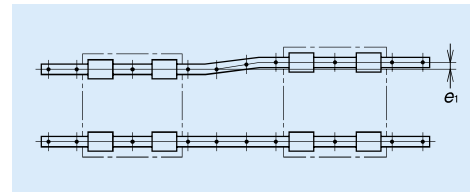

Fig. 6

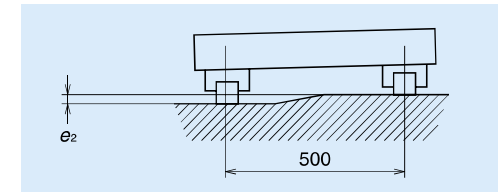

Fig. 7

Table 6

Unit: μm

Value	Preload	Model No.		
		LH08	LH10	LH12
Permissible values of parallelism in two rails e1	Z0	9	12	19
	Z1	8	11	18
Permissible values of parallelism (height) in two rails e2	Z0	375μm/500mm		
	Z1	330μm/500mm		

(2) Shoulder height of the mounting surface and corner radius r

Table 7

Unit: mm

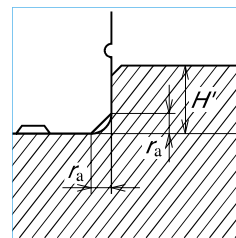

Fig. 8 Shoulder for the rail datum surface

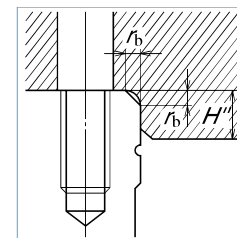

Fig. 9 Shoulder for the ball slide datum surface

Model No.	Corner radius (maximum)		Shoulder height	
	ra	rb	H'	H''
LH08	0.3	0.5	1.8	3
LH10	0.3	0.5	2.1	4
LH12	0.5	0.5	2.7	4

6. Lubrication accessory

Model of LH12 can select drive-in type grease fitting as an option.

For the models of LH08 to LH10, apply grease directly to the ball grooves of rail using a point nozzle.

Grease fitting

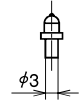

Drive-in type

Fig. 10

7. Dust-proof components

(1) Standard specification

The LH Series can be readily used as they have a dust protection means for normal conditions. As the standard equipment, the ball slides have an end seal on both ends, and bottom seals at the bottom.

However, the bottom seals are not used to LH08 and 10.

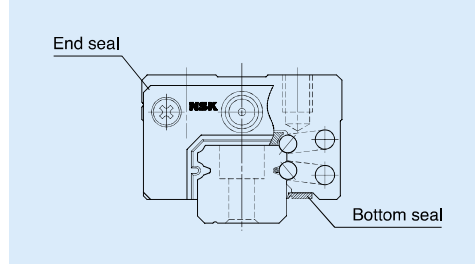

Fig. 11

Table 8 Seal friction per ball slide (maximum value)

Unit: N				
Series	Size	08	10	12
LH		0.5	1	1.5

(2) NSK K1™ lubrication unit

Table 9 shows the dimension of linear guides equipped with the NSK K1 lubrication unit

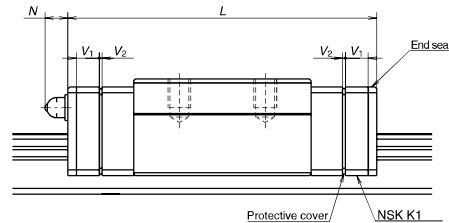

Table 9

Unit: mm

Model No.	Ball slide length	Ball slide model	Standard ball slide length	Ball slide length installed with two NSK K1 L	Per NSK K1 thickness V ₁	Protective cover thickness V ₂	Protruding area of the grease fitting N
LH08	Standard	AN	24	31	3	0.5	—
LH10	Standard	AN	31	40	4	0.5	—
LH12	Standard	AN	45	54	4	0.5	(4)

Notes: 1) NSK K1 for food and medical equipment are available for LH12.

2) Ball slide length equipped with NSK K1 = (Standard ball slide length) + (Thickness of NSK K1, V₁ × Number of NSK K1) + (Thickness of the protective cover, V₂ × 2)

(3) Cap to plug the rail mounting bolt hole

Table 10 Caps to plug rail bolt hole

Model No.	Bolt to secure rail	Cap reference No.	Quantity /case
LH12	M3	LG-CAP/M3	20

8. Reference number

Reference numbers shall be set to individual NSK linear guide when its specifications are finalized, and it is indicated on its specification drawing.

Please specify the reference number, except design serial number, to identify the product when ordering, requiring estimates, or inquiring about specifications from NSK.

(1) Reference number for preloaded assembly

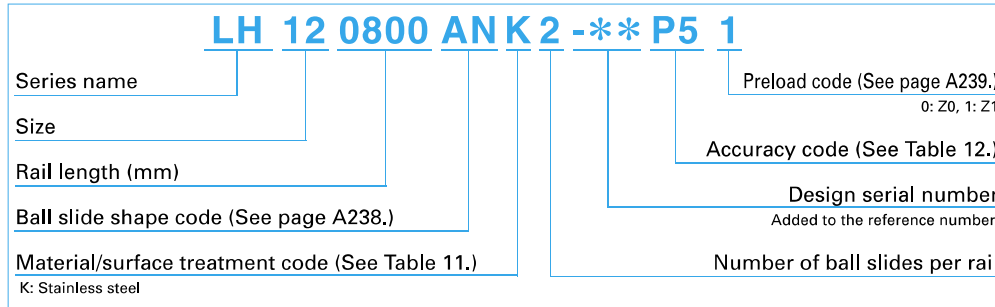

Table 11 Material/surface treatment code

Code	Description
K	Stainless steel
H	Stainless steel with surface treatment
Z	Other, special

Table 12 Accuracy code

Accuracy	Standard (Without NSK K1)	With NSK K1	With NSK K1 for food and medical equipment
Super precision grade	P4	K4	F4
High precision grade	P5	K5	F5
Precision grade	P6	K6	F6
Normal grade	PN	KN	FN

Note: Refer to pages A38 and A61 for NSK K1 lubrication unit.

9. Dimensions

LH 12 0800 AN K 2 - P5 1**

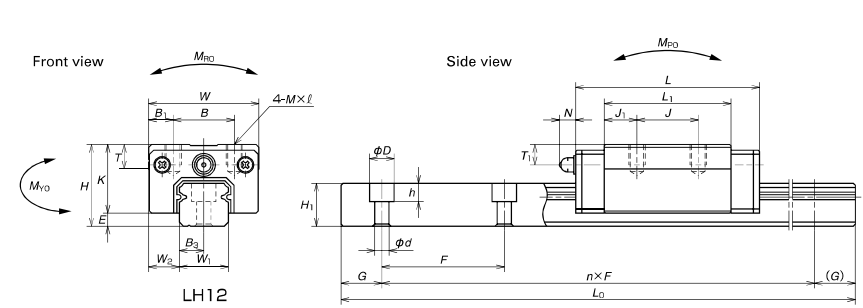
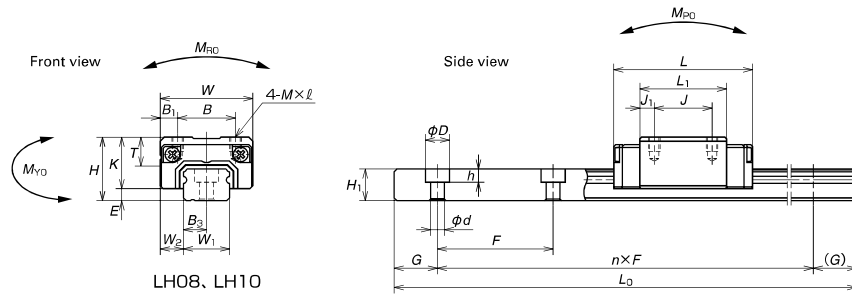
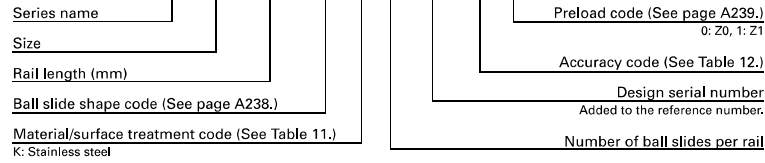

Model No.	Assembly			Ball slide										Width	Height	
	Height	E	W ₂	Width	Length	Mounting hole				Grease fitting						
						B	J	M × pitch × l	L ₁	K	T	Hole size	T ₁			N
LH08AN	11	2.1	4	16	24	10	10	M2×0.4×2.5	15	8.9	—	—	—	—	8	5.5
LH10AN	13	2.4	5	20	31	13	12	M2.6×0.45×3	20.2	10.6	6	—	—	—	10	6.5
LH12AN	20	3.2	7.5	27	45	15	15	M4×0.7×5	31	16.8	6	φ3	5	4	12	10.5

Notes: 1) LH08 does not have a ball retainer. Be aware that balls fall out when the ball slide is withdrawn from the rail.

Unit: mm

Pitch	Rail			Basic load rating								Weight	
	Mounting bolt hole	G	Max. length	Dynamic		Static	C ₀	Static moment (N-m)				Ball slide (g)	Rail (g/100 mm)
				[50km]	[100km]			M _{RO}	M _{FO}		M _{VO}		
F	d × D × h	reference	L _{0max}	C ₅₀ (N)	C ₁₀₀ (N)	(N)	M _{RO}	One slide	Two slides	One slide	Two slides		
20	2.4×4.2×2.3	7.5	375	1 240	985	2 630	7.25	4.55	32.5	3.8	27.2	13	31
25	3.5×6×3.5	10	600	2 250	1 790	4 500	16.2	10.5	73.0	8.8	61.0	26	44
40	3.5×6×4.5	15	800	5 650	4 500	11 300	47.5	41.5	254	35	214	82	88

2) The basic load rating comply with the ISO standard. (ISO 14728-1, 14728-2)
 C₅₀: the basic dynamic load rating for 50 km rated fatigue life C₁₀₀: the basic dynamic load rating for 100 km rated fatigue life