

Optimized Long-Life Cylindrical Roller Bearings for Continuous Casting Machines



Bearings for Continuous Casting Machines

Bearings for Guide Rolls

Bearings used in the guide rolls of continuous casting machines are exposed to harsh conditions such as heavy load at ultra-low-speed in a hot and wet environment. High-performance bearings with longer life and higher reliability are desirable under such circumstances.



NSK has successfully developed innovative cylindrical rolling bearings through our extensive knowledge, decades of experience in production and in the steel industry, cutting-edge analysis technology, and an optimized design figure. Furthermore, these bearings feature improved handling performance that suits the required functions of guide rolls.

Cutaway View

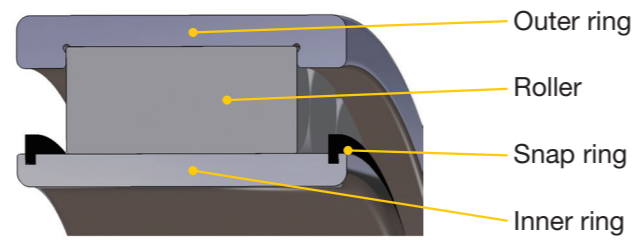

Features

Long Life & High Reliability

Extremely high capacity through optimized design.

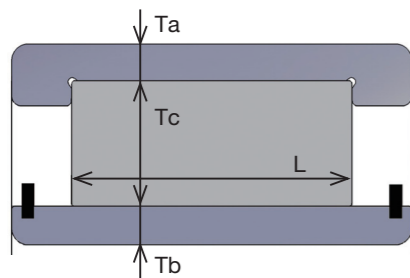

Optimized parameters
 $\propto Ta, Tb, Tc, L \text{ \& } Z$ (Z: number of rollers)

Self-Aligning Functionality

Load distribution is equal across the bearing, even during roll-bending & expansion.

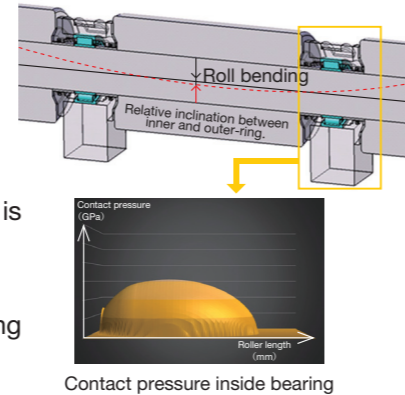

Smooth Relief Roll Expansion

Smooth relief between rollers and inner ring.

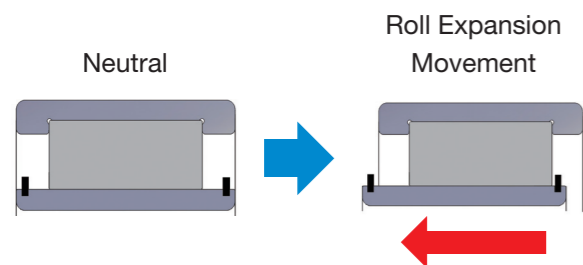

Easy Handling

From assembly to housing, these bearing are easy to handle without any special tools. This improves work efficiency and safety.

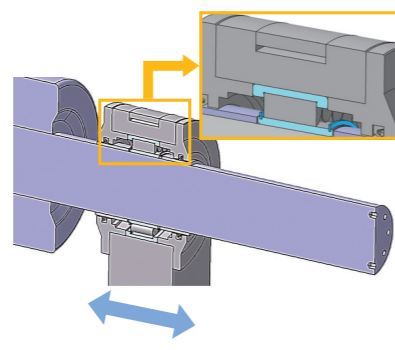

NSK installed one of these bearings for continuous casting machines at a customer site to perform a real-world test. They fulfilled all the specifications required and yielded good results for operation stability, earning high praise from the client.

Field Test

Bearing number: 160NUB40VC4
 Boundary dimensions: $\phi d160 \text{ mm} \times \phi D240 \text{ mm} \times B80 \text{ mm}$
 Basic load ratings $Cr: 765 \text{ (kN)}, Cor: 1,360 \text{ (kN)}$

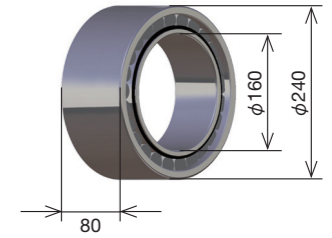

Continuous Casting Machine (for Heavy Plates)

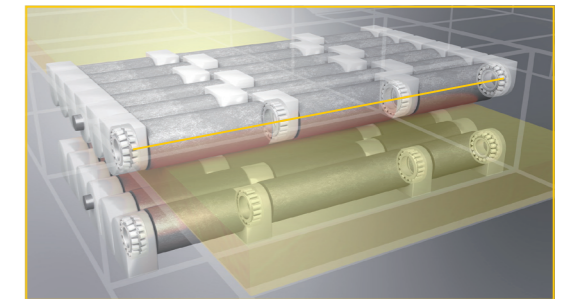
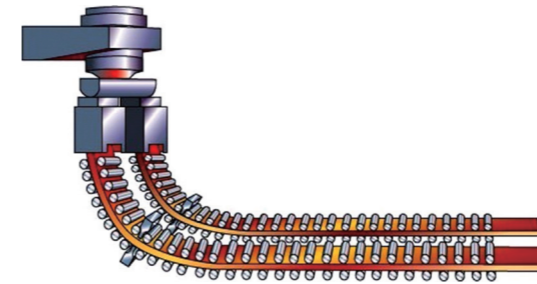

Roll Segment Unit

Roll Arrangement

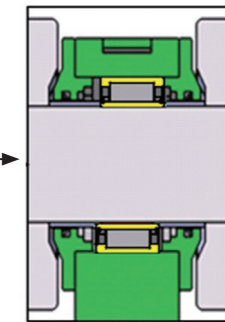
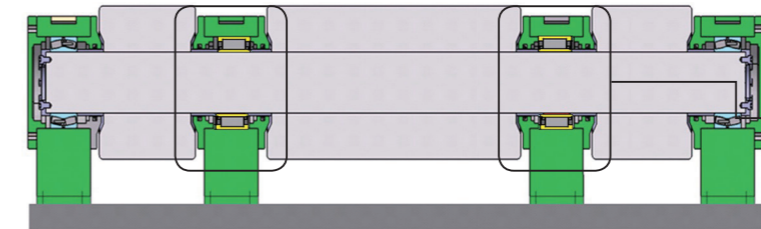

Arrangement of Top & Bottom Roll

Axle Box Structure

Test Results

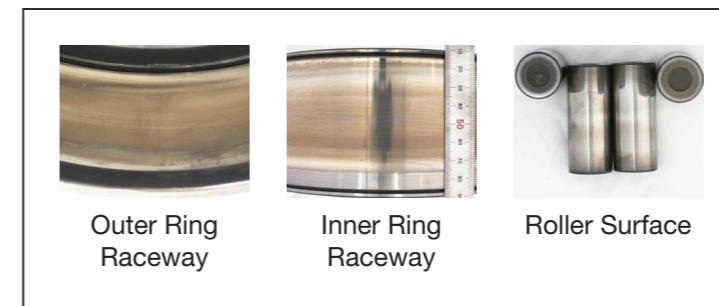

Test period: 9 months
 Production amount: Approx. 1.0M tons
 Appearance: No abnormalities detected
 (Possible for continuous use)

Bearing Number List

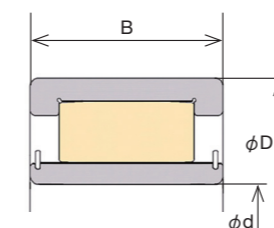

Dimensions (mm)			Bearing No.	Basic Load Ratings (kN)	
d	D	B		Cr	Cor
120	180	60	120NUB40V	450	740
130	200	69	130NUB40V	570	950
140	210	69	140NUB40V	560	960
150	225	75	150NUB40V	665	1160
160	240	80	160NUB40V	765	1360

Worldwide Sales Offices

P: Phone ☆: Head Office

NSK LTD. HEADQUARTERS, TOKYO JAPAN

INDUSTRIAL MACHINERY BUSINESS DIVISION-HEADQUARTERS P: +81-3-3779-7227
AUTOMOTIVE BUSINESS DIVISION-HEADQUARTERS P: +81-3-3779-7189

Africa

South Africa:

NSK SOUTH AFRICA (PTY) LTD.

SANDTON P: +27-11-458-3600

Aisia and Oceania

Australia:

NSK AUSTRALIA PTY. LTD.

MELBOURNE ☆ P: +61-3-9765-4400
SYDNEY P: +61-2-9839-2300
BRISBANE P: +61-7-3347-2600
PERTH P: +61-8-9256-5000

New Zealand:

NSK NEW ZEALAND LTD.

AUCKLAND P: +64-9-276-4992

China:

NSK (SHANGHAI) TRADING CO., LTD.

JIANGSU ☆ P: +86-512-5796-3000

NSK (CHINA) INVESTMENT CO., LTD.

JIANGSU P: +86-512-5796-3000
BEIJING P: +86-10-6590-8161
TIAN JIN P: +86-22-8319-5030
CHANGCHUN P: +86-431-8898-8682
SHENYANG P: +86-24-2334-2868
DALIAN P: +86-411-8800-8168
NANJING P: +86-25-8472-6671
FUZHOU P: +86-591-8380-1030
WUHAN P: +86-27-8556-9630
QINGDAO P: +86-532-5568-3877
GUANGZHOU P: +86-20-3817-7800
CHANGSHA P: +86-731-8571-3100
LUOYANG P: +86-379-6069-6188
XI'AN P: +86-29-8765-1896
CHONGQING P: +86-23-6806-5310
CHENGDU P: +86-28-8528-3680

NSK CHINA SALES CO., LTD.

JIANGSU P: +86-512-5796-3000

NSK HONG KONG LTD.

HONG KONG ☆ P: +852-2739-9933
SHENZHEN P: +86-755-25904886

Taiwan:

TAIWAN NSK PRECISION CO., LTD.

TAIPEI ☆ P: +886-2-2509-3305
TAICHUNG P: +886-4-2708-3393
TAINAN P: +886-6-505-5861

TAIWAN NSK TECHNOLOGY CO., LTD.

TAIPEI ☆ P: +886-2-2509-3305
TAICHUNG P: +886-4-2358-2945
TAINAN P: +886-6-505-5861

India:

NSK INDIA SALES CO.PVT.LTD.

CHENNAI ☆ P: +91-44-2847-9600
DELHI P: +91-124-4838000

MUMBAI P: +91-22-2838-7787

Indonesia:

PT. NSK INDONESIA

JAKARTA P: +62-21-252-3458

Korea:

NSK KOREA CO., LTD.

SEOUL P: +82-2-3287-0300

Malaysia:

NSK BEARINGS (MALAYSIA) SDN.BHD.

SHAH ALAM ☆ P: +60-3-7803-8859
PRAI P: +60-4-3902275
JOHOR BAHRU P: +60-7-3546290
IPOH P: +60-5-2555000

Philippines:

NSK REPRESENTATIVE OFFICE

MANILA P: +63-2-893-9543

Singapore:

NSK INTERNATIONAL (SINGAPORE) PTE LTD.

SINGAPORE P: +65-6496-8000

NSK SINGAPORE (PRIVATE) LTD.

SINGAPORE P: +65-6496-8000

Thailand:

NSK BEARINGS (THAILAND) CO., LTD.

BANGKOK P: +66-2320-2555

Vietnam:

NSK VIETNAM CO., LTD.

HANOI P: +84-24-3955-0159

NSK REPRESENTATIVE OFFICE

HO CHI MINH CITY P: +84-28-3822-7907

Europe

United Kingdom:

NSK EUROPE LTD. (EUROPEAN HEADQUARTERS)

MAIDENHEAD P: +44-1628-509-800

NSK UK LTD.

NEWARK P: +44-1636-605-123

France:

NSK FRANCE S.A.S.

PARIS P: +33-1-30-57-39-39

Germany:

NSK DEUTSCHLAND GMBH

DUSSELDORF ☆ P: +49-2102-4810
STUTT GART P: +49-711-79082-0
WOLFSBURG P: +49-5361-27647-10

Italy:

NSK ITALIA S.P.A.

MILANO P: +39-299-5191

Netherlands:

NSK EUROPEAN DISTRIBUTION CENTRE B.V.

TILBURG P: +31-13-4647647

Poland:

NSK REPRESENTATIVE OFFICE

WARSAW P: +48-22-645-1525

Russia:

NSK POLSKA SP. Z O.O.

SAINT-PETERSBURG P: +7-812-332-5071

Spain:

NSK SPAIN S.A.

BARCELONA P: +34-93-289-2763

Turkey:

NSK RULMANLARI ORTA DOGU TIC. LTD. STI.

ISTANBUL P: +90-216-477-7111

United Arab Emirates:

NSK BEARINGS GULF TRADING CO.

DUBAI P: +971-4-804-8207

North and South America

United States of America:

NSK AMERICAS, INC. (AMERICAN HEADQUARTERS)

ANN ARBOR P: +1-734-913-7500

NSK CORPORATION

ANN ARBOR P: +1-734-913-7500

NSK PRECISION AMERICA, INC.

FRANKLIN ☆ P: +1-317-738-5000

SAN JOSE

P: +1-408-944-9400

NSK LATIN AMERICA, INC.

MIAMI P: +1-305-477-0605

Canada:

NSK CANADA INC.

TORONTO ☆ P: +1-905-890-0740

MONTREAL

P: +1-514-633-1220

VANCOUVER

P: +1-877-994-6675

Argentina:

NSK ARGENTINA SRL

BUENOS AIRES P: +54-11-4704-5100

Brazil:

NSK BRASIL LTDA.

SUZANO ☆ P: +55-11-4744-2500

BELO HORIZONTE

P: +55-31-3274-2591

JOINVILLE

P: +55-47-3422-2239

PORTO ALEGRE

P: +55-51-3346-7851

RECIFE

P: +55-81-3326-3781

Peru:

NSK PERU S.A.C.

LIMA P: +51-1-493-4385

Mexico:

NSK RODAMIENTOS MEXICANA, S.A. DE C.V.

MEXICO CITY ☆ P: +52-55-3682-2900

MONTERREY

P: +52-81-8000-7300

<As of February 2018>

For the latest information, please refer to the NSK website.

www.nsk.com

NSK Ltd. has a basic policy not to export any products or technology designated as controlled items by export-related laws. When exporting the products in this brochure, the laws of the exporting country must be observed. Specifications are subject to change without notice and without any obligation on the part of the manufacturer. Every care has been taken to ensure the accuracy of the data contained in this brochure, but no liability can be accepted for any loss or damage suffered through errors or omissions. We will gratefully acknowledge any additions or corrections.

For more information about NSK products, please contact: _____

