

GM TYPE

— Single Type —

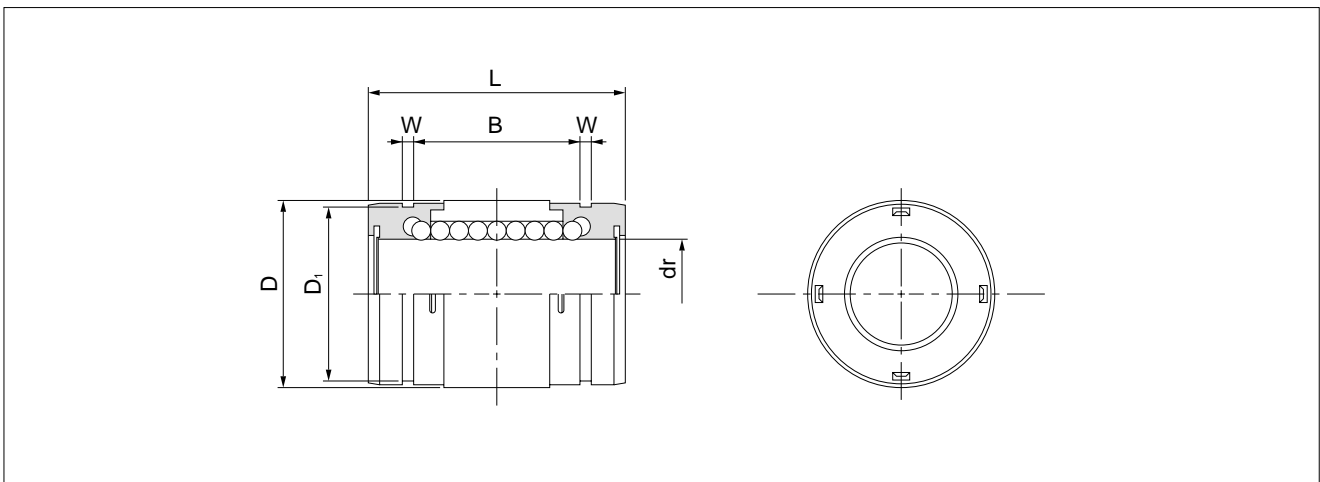
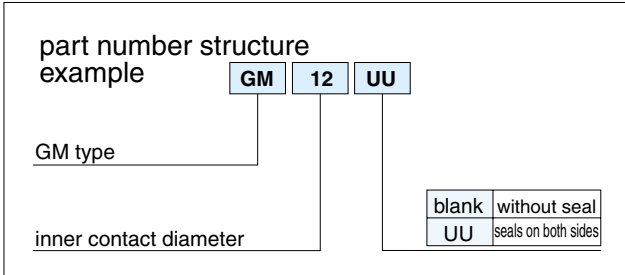

part number	number of ball circuits	major dimensions								basic load rating		mass g	
		dr		D		L	B	W	D ₁	dynamic C N	static C ₀ N		
		mm	tolerance μm	mm	tolerance μm								
GM 6	4	6	0	12	0	19	11.3	1.1	11.5	206	265	5	
GM 8	4	8		15	-11	24	15.3	1.1	14.3	274	392	10	
GM10	4	10		19	0	29	19.4	1.3	18	372	549	18	
GM12	4	12	21	0		30	20.4	1.3	20	510	784	23	
GM13	4	13	23	-13		32	20.4	1.3	22	510	784	27	
GM16	4	16	-9	28	0	37	23.3	1.6	27	774	1,180	45	
GM20	6	20		32		0	42	27.3	1.6	30.5	882	1,370	70
GM25	6	25		40		-10	59	37.3	1.85	38	980	1,570	150
GM30	6	30	45	-16	64		40.8	1.85	43	1,570	2,740	180	

1N ≙ 0.102kgf

GM-W TYPE

— Double-Wide Type —

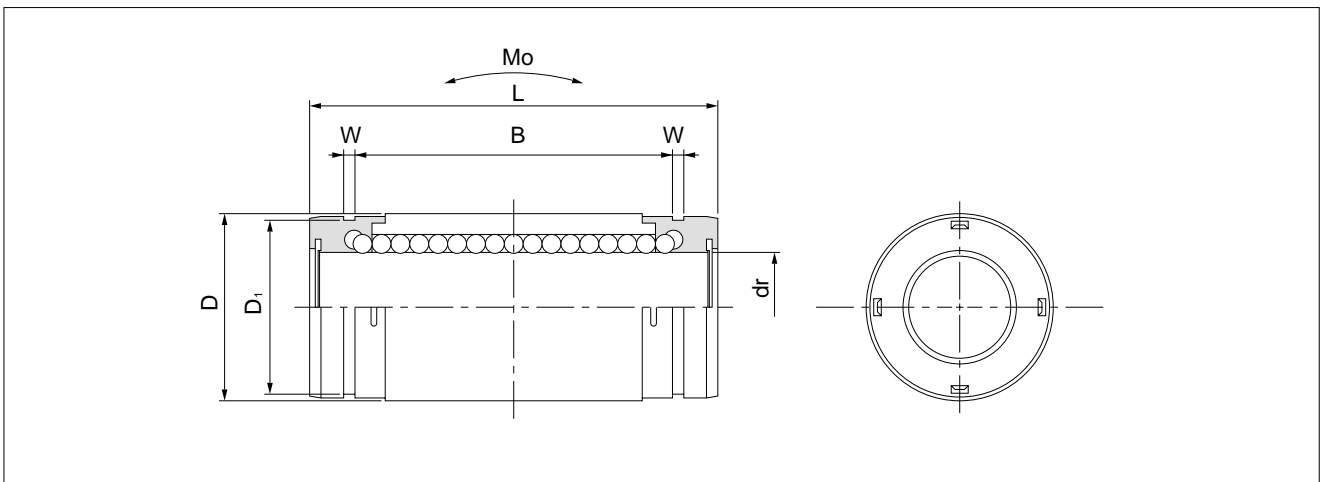
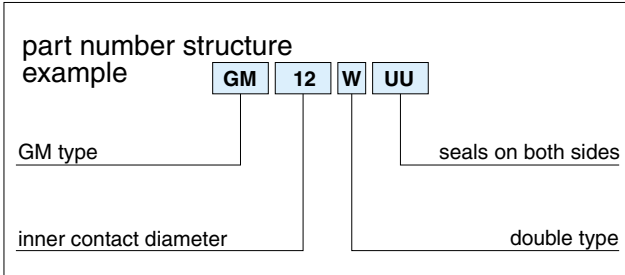
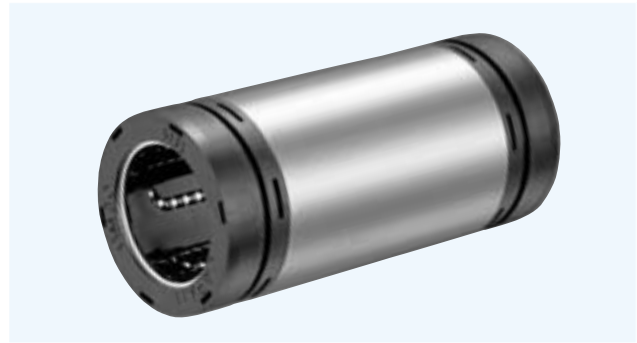

part number	number of ball circuits	major dimensions								basic load rating		allowable static moment Mo N·m	mass g
		dr		D		L	B	W	D ₁	dynamic C N	static C ₀ N		
		mm	tolerance μm	mm	tolerance μm								
GM 6W UU	4	6	0	12	0	28	20.3	1.1	11.5	323	530	1.5	9
GM 8W UU	4	8	-10	15	-13	36	27.3	1.1	14.3	431	784	3.3	18
GM10W UU	4	10		19	0	41	31.4	1.3	18	588	1,100	5.0	31
GM12W UU	4	12		21	0	46	36.4	1.3	20	813	1,570	7.6	42
GM13W UU	4	13	-12	23	-16	48	36.4	1.3	22	813	1,570	8.1	50
GM16W UU	4	16		28	0	53	39.3	1.6	27	1,230	2,350	13.8	76
GM20W UU	6	20		32	0	65	50.3	1.6	30.5	1,400	2,740	20.0	130
GM25W UU	6	25	-12	40	-19	91	69.3	1.85	38	1,560	3,140	34.8	280
GM30W UU	6	30		45	-19	99	75.8	1.85	43	2,490	5,490	57.5	334

1N≒0.102kgf 1N·m≒.102kgf·m

GMF-W TYPE

– Round Flange Double-Wide Type –

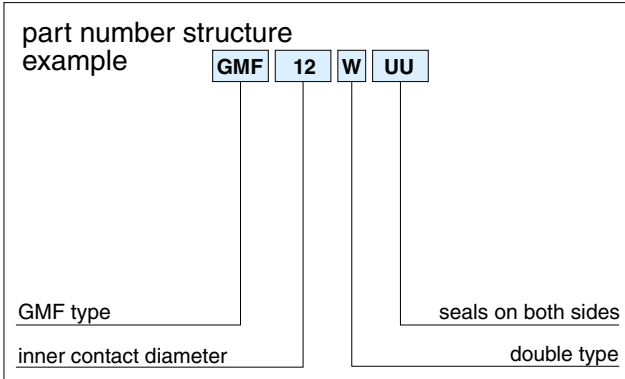
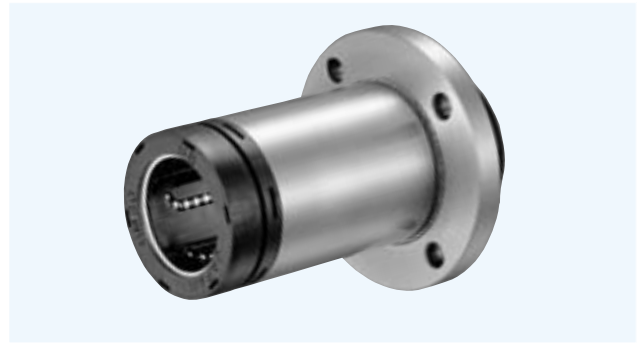

part number	number of ball circuits	major dimensions					
		dr		D		L	H
		mm	tolerance μm	mm	tolerance μm		
GMF 6W UU	4	6	0 -10	12	0	28	17.8
GMF 8W UU	4	8		15	-13	36	25.1
GMF10W UU	4	10		19	0 -16	41	28.2
GMF12W UU	4	12		21		46	34.2
GMF13W UU	4	13		23		48	34.7
GMF16W UU	4	16	28	53	38.3		
GMF20W UU	6	20	0 -12	32	0 -19	65	49.2
GMF25W UU	6	25		40		91	70.5
GMF30W UU	6	30		45		99	74.3

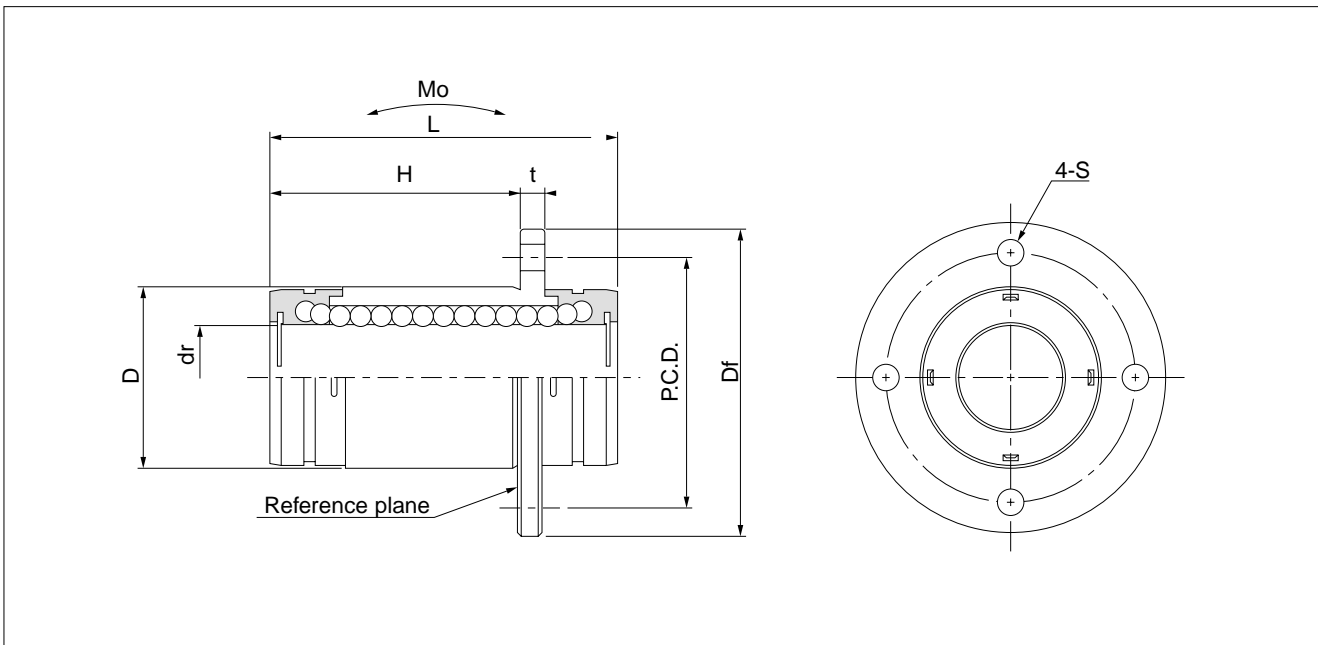

				perpen- dicularity	basic load rating		allowable static moment Mo	mass	shaft diameter
Df	t	P.C.D	S		dynamic C	static Co			
mm	mm	mm	mm	μm	N	N	$\text{N} \cdot \text{m}$	g	mm
28	4	20	3.5	15	323	530	1.5	25	6
32	4	24	3.5		431	784	3.3	38	8
40	4	29	4.5		588	1,100	5.0	62	10
42	4	32	4.5		813	1,570	7.6	75	12
43	4	33	4.5		813	1,570	8.1	83	13
48	4	38	4.5		1,230	2,350	13.8	115	16
54	5	43	5.5	20	1,400	2,740	20.0	188	20
62	5	51	5.5		1,560	3,140	34.8	350	25
74	8	60	6.6		2,490	5,490	57.5	502	30

1N \approx 0.102kgf 1N \cdot m \approx .102kgf \cdot m

GMK-W TYPE

— Square Flange Double-Wide Type —

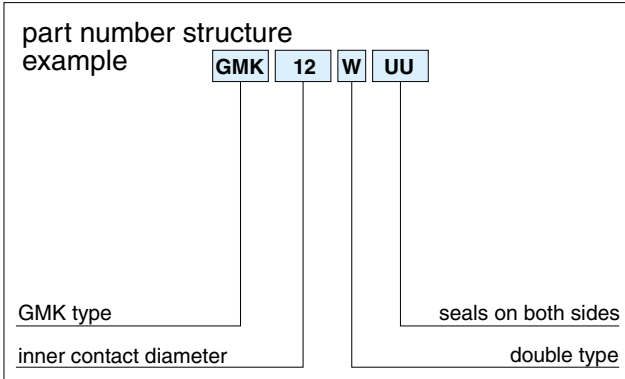
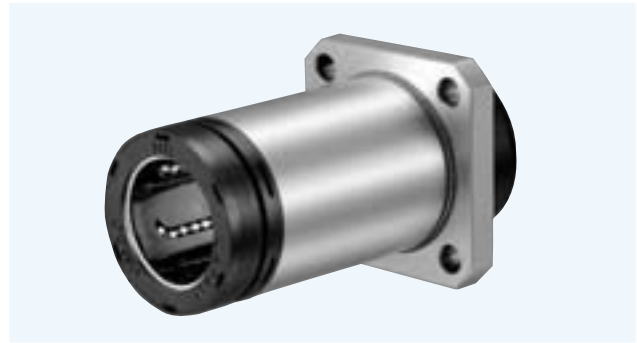

part number	number of ball circuits	major dimensions					
		dr		D		L	H
		mm	tolerance μm	mm	tolerance μm		
GMK 6W UU	4	6	0 -10	12	0	28	17.8
GMK 8W UU	4	8		15	-13	36	25.1
GMK10W UU	4	10		19	0 -16	41	28.2
GMK12W UU	4	12		21		46	34.2
GMK13W UU	4	13		23		48	34.7
GMK16W UU	4	16		28		53	38.3
GMK20W UU	6	20	0 -12	32	0	65	49.2
GMK25W UU	6	25		40	-19	91	70.5
GMK30W UU	6	30		45		99	74.3

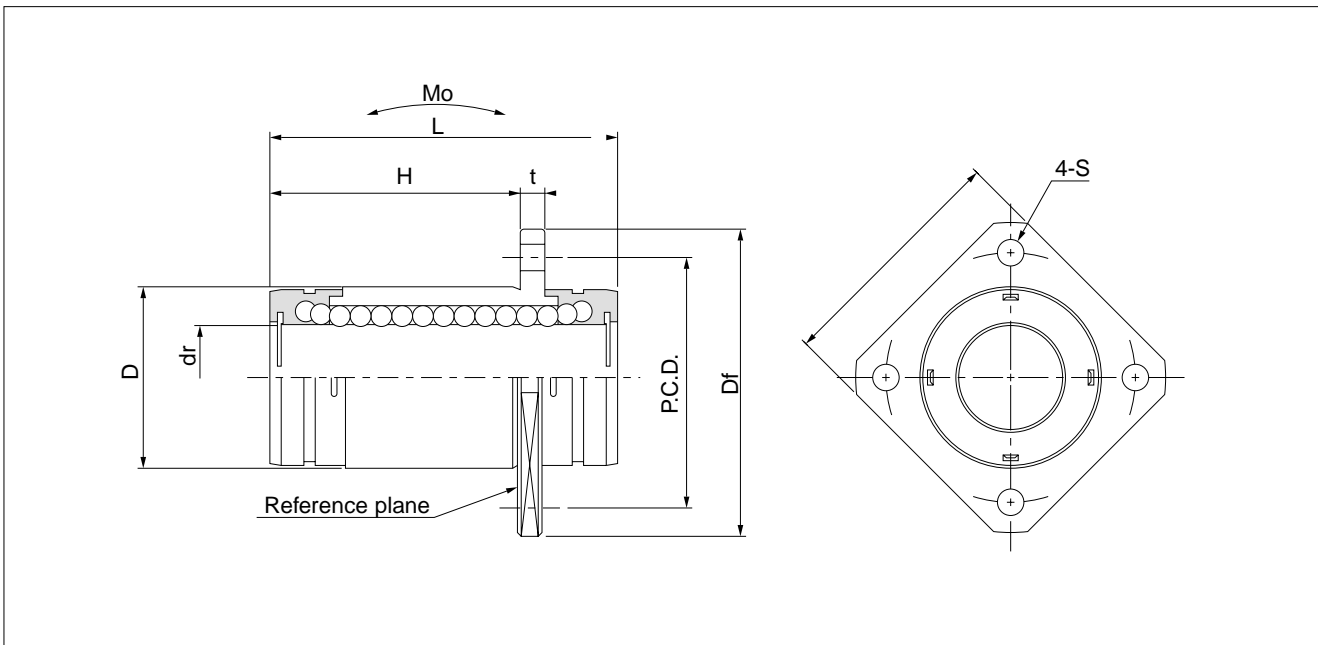

flange					perpen- dicularity μm	basic load rating		allowable static moment M_o $\text{N} \cdot \text{m}$	mass g	shaft diameter mm
Df mm	t mm	P.C.D mm	K mm	S mm		dynamic C N	static C_o N			
28	4	20	22	3.5	15	323	530	1.5	20	6
32	4	24	25	3.5		431	784	3.3	32	8
40	4	29	30	4.5		588	1,100	5.0	50	10
42	4	32	32	4.5		813	1,570	7.6	63	12
43	4	33	34	4.5		813	1,570	8.1	72	13
48	4	38	37	4.5		1,230	2,350	13.8	99	16
54	5	43	42	5.5	20	1,400	2,740	20.0	165	20
62	5	51	50	5.5		1,560	3,140	34.8	325	25
74	8	60	58	6.6		2,490	5,490	57.5	437	30

$1\text{N} \cong 0.102\text{kgf}$ $1\text{N} \cdot \text{m} \cong .102\text{kgf} \cdot \text{m}$

GMT-W TYPE

— Two Side Cut Double-Wide Flange Type —

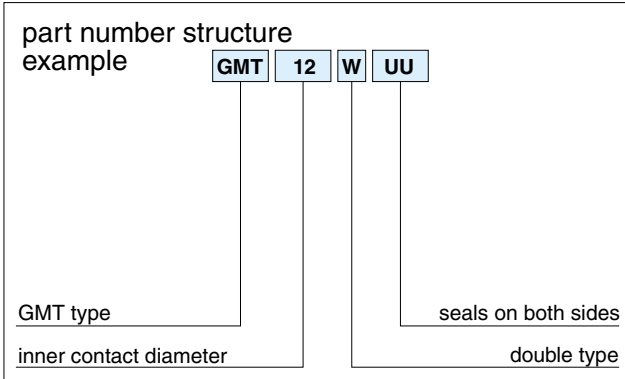
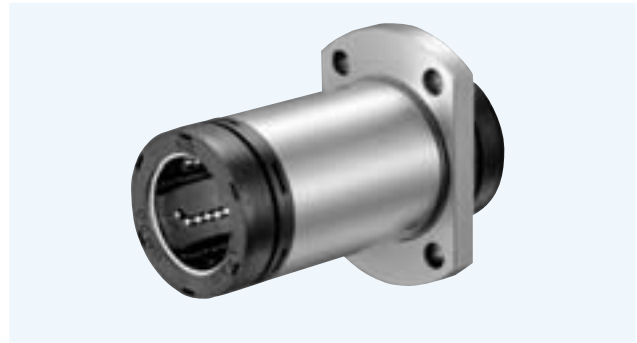

part number	number of ball circuits	major dimensions					
		dr		D		L	H
		mm	tolerance μm	mm	tolerance μm		
GMT 6W UU	4	6	0 -10	12	0	28	17.8
GMT 8W UU	4	8		15	-13	36	25.1
GMT10W UU	4	10		19	0 -16	41	28.2
GMT12W UU	4	12		21		46	34.2
GMT13W UU	4	13		23		48	34.7
GMT16W UU	4	16	28	53	38.3		
GMT20W UU	6	20	0 -12	32	0 -19	65	49.2
GMT25W UU	6	25		40		91	70.5
GMT30W UU	6	30		45		99	74.3

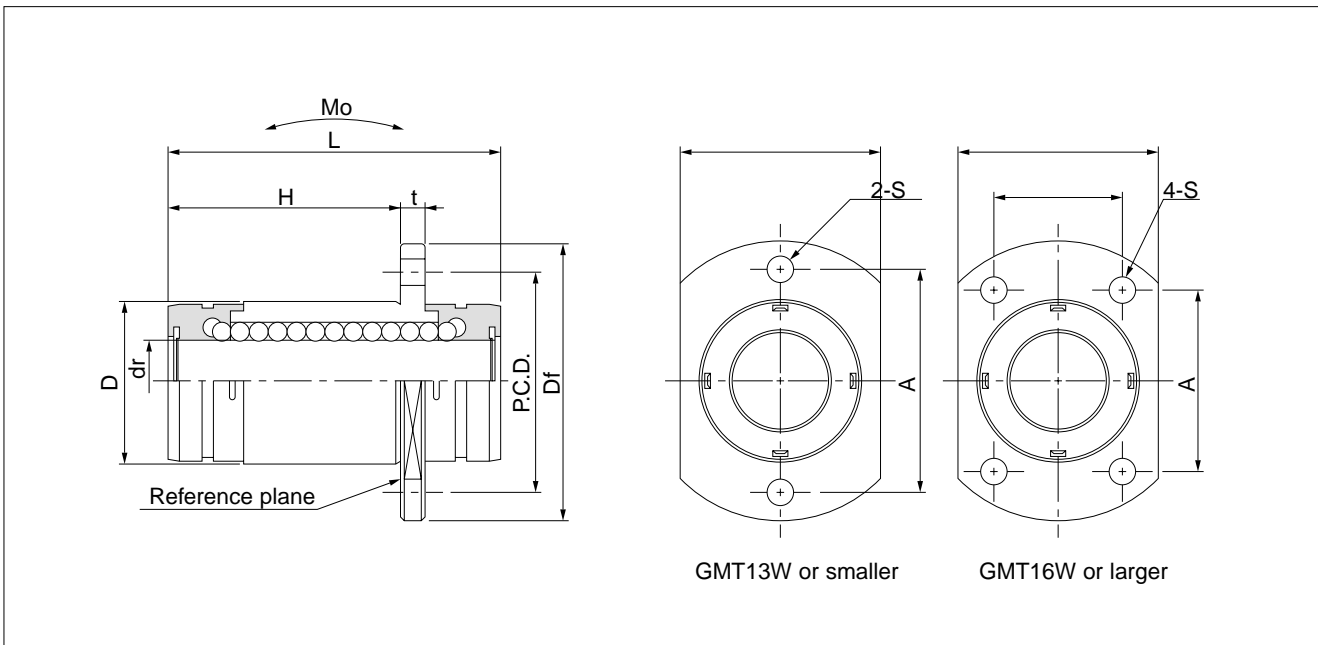

flange						perpen- dicularity μm	basic load rating		allowable static moment M_o $\text{N} \cdot \text{m}$	mass g	shaft diameter mm
Df mm	t mm	W mm	A mm	F mm	S mm		C N	Co N			
28	4	18	20	—	3.5	15	323	530	1.5	21	6
32	4	21	24	—	3.5		431	784	3.3	33	8
40	4	25	29	—	4.5		588	1,100	5.0	52	10
42	4	27	32	—	4.5		813	1,570	7.6	65	12
43	4	29	33	—	4.5		813	1,570	8.1	74	13
48	4	34	31	22	4.5		1,230	2,350	13.8	104	16
54	5	38	36	24	5.5	20	1,400	2,740	20.0	171	20
62	5	46	40	32	5.5		1,560	3,140	34.8	331	25
74	8	51	49	35	6.6		2,490	5,490	57.5	447	30

1N \approx 0.102kgf 1N \cdot m \approx .102kgf \cdot m