

STROKE BUSH

The NB stroke bush is a linear and rotational motion mechanism utilizing the rotational motion of ball elements between an outer cylinder and a shaft. It is compact and can with stand high loading. The retainer is made of a light metal alloy with high wear resistance. Smooth motion is achieved under high-speed and high-acceleration conditions. Although the linear motion is limited to a predetermined stroke distance, the smooth combination of linear and rotational motions is achieved with very little frictional resistance. The NB stroke bush may be conveniently used in a variety of applications.

STRUCTURE AND ADVANTAGES

The retainer in the NB stroke bush positions the ball elements in a zigzag arrangement. The inner surface of the outer cylinder is finished by grinding, resulting in the smooth motion of the ball elements. Each of the ball elements is held in a separate hole and smooth motion is achieved for both rotational motion and linear motion. The retainer moves half the distance of the linear motion, therefore, the stroke distance is limited to approximately twice the distance the retainer can travel within the outer cylinder. The actual travel distance should be limited to 80% of the travel distances as listed in the dimensional tables.

● High Precision

High-carbon, chromium-bearing steel is used for the outer cylinder. It is heat treated and ground to achieve high rigidity and accuracy.

● Ease of Mounting / Replacement

The highly accurate fabrication of the NB stroke bush results in uniform dimensions, facilitating parts replacement and housing fabrication.

● Light Weight / Saving of Space

The use of an aluminum alloy for the retainer and the thin-wall outer cylinder make the NB stroke bush light weight and compact.

● Lubrication

Lubrication holes are provided on the oil grooves of the outer cylinder, making it easy to lubricate the NB stroke bush.

Figure F-1 Basic Structure of NB Stroke Bush

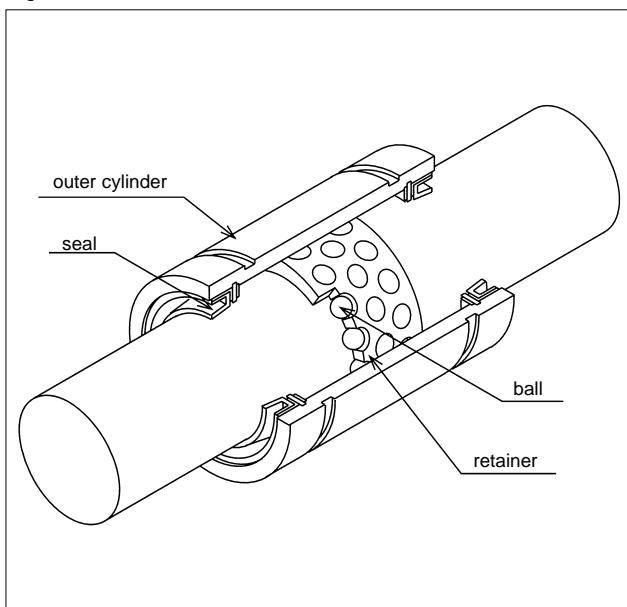

ACCURACY

The accuracies of the NB stroke bush are stated in the dimensional tables. Since the outer cylinder deforms due to tension from the retaining ring, the dimension of the outer cylinder is an average value at points P, where calculated using the following equation:

$$W = 4 + \frac{L}{8}$$

W : the distance from the end of the outer race to measurement point P
L : the length of the outer race

FIT

The inner contact diameters of the NB stroke bush are listed in the dimensional tables. The shaft diameter tolerance should be selected to achieve the desired amount of radial clearance. High-speed linear motion can cause the retainer to slip due to inertial force. An interference fit of -3 to $-10 \mu\text{m}$

Figure F-2 Outer Cylinder Measurement Points

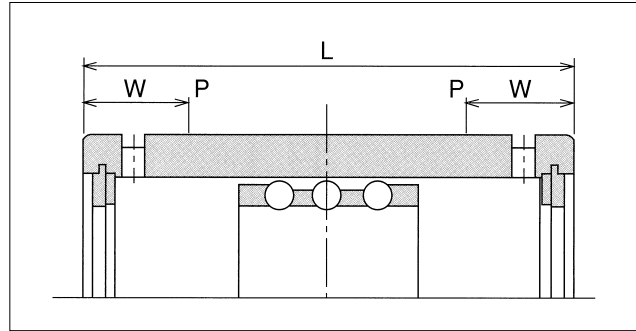

will compensate for such slip. The fits generally used between the shaft and the housing are listed in the table below.

Table F-1

normal operating condition		vertical use or highly accurate case	
shaft	housing	shaft	housing
k5,m5	H6,H7	n5,p6	J6,J7

RATED LOAD AND RATED LIFE

The relationship between the rated load and life of the stroke bush is expressed as follows:

$$L = \left(\frac{C}{P}\right)^3$$

L : the rated life (10^6 rotations), C : the basic dynamic rated load (N)
P : load (N)

- For rotation/stroke combined motion

$$L_h = \frac{10^6 \cdot L}{60 \sqrt{(dm \cdot n)^2 + (10 \cdot S \cdot n_1)^2} / dm}$$

- For stroke motion

$$L_h = \frac{10^6 \cdot L}{600 \cdot S \cdot n_1 / (\pi \cdot dm)}$$

L_h : travel life in time (hr) S : stroke distance (mm)
n : revolution per min. (rpm)
 n_1 : stroke frequency per min. (cpm)
 dm : ball pitch diameter (mm) ≈ 1.15 dr

ALLOWABLE SPEED FOR COMBINED ROTATION/STROKE MOTION

The allowable speed for combined rotation and stroke motion is obtained from the following equation:

$$DN \geq dm \cdot n + 10 \cdot S \cdot n_1$$

The value of DN is given as follows depending on the lubrication method.

for oil lubrication	DN=600,000
for grease lubrication	DN=300,000

note..... $n \leq 5,000$ S · $n_1 \leq 50,000$

SR-UU TYPE

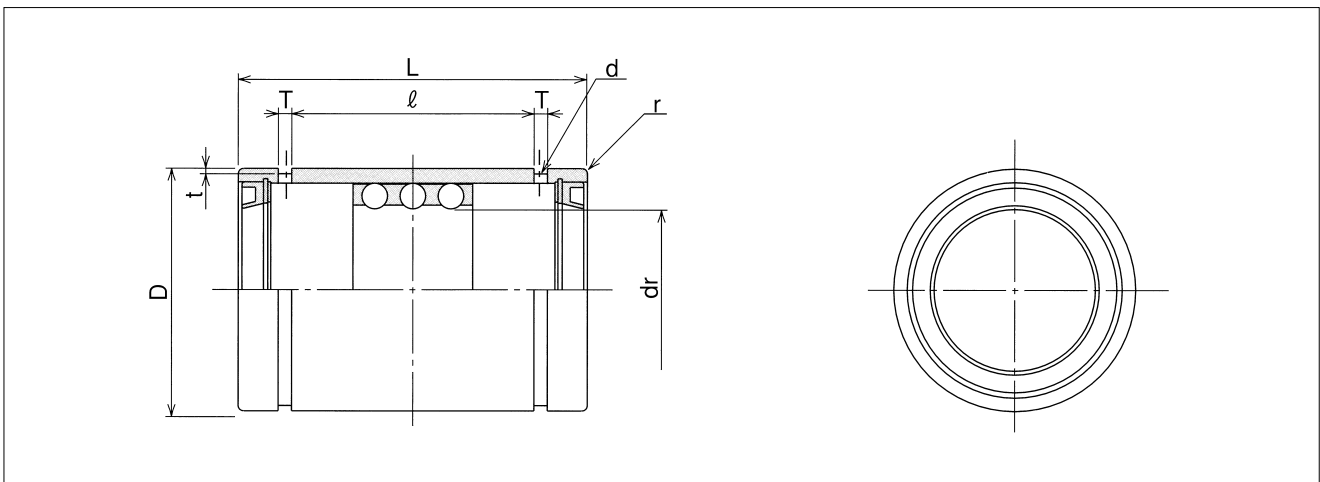
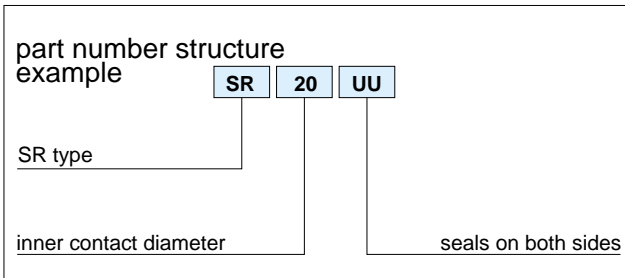

part number	maximum stroke mm	number of rows	major dimensions											basic load rating		mass g
			dr		D		L		\varnothing	T	t	d	r	dynamic C N	static Co N	
			mm	tolerance μm	mm	tolerance μm	mm	tolerance mm								
SR 8UU	14	3	8	+22	15	0/-11	24	-0.2	12.3	1.5	0.5	1.2	0.5	343	245	15.6
SR 10UU	16	3	10	+13	19	0	30		15.5	1.5	0.5	1.2	0.5	637	461	28.8
SR 12UU	17	3	12	+27	23	-13	32		17.1	1.5	0.5	1.2	0.5	1,070	813	42
SR 16UU	24	3	16	+16	28		37		21.1	1.5	0.7	1.3	0.5	1,180	990	71
SR 20UU	32	3	20	+33	32	0	45	-0.3	26.8	2	0.7	1.5	0.5	1,260	1,170	99
SR 25UU	32	3	25	+20	37	-16	45		26.8	2	0.7	1.6	1	1,330	1,330	117
SR 30UU	65	3	30		45		65		45.1	2.5	1	2	1	2,990	3,140	205
SR 35UU	75	3	35	+41	52	0	70		50.1	2.5	1	2	1.5	3,140	3,530	329
SR 40UU	91	3	40	+25	60	-19	80	0	59.9	2.5	1	2	1.5	4,120	4,800	516
SR 50UU	120	3	50	+49	72	0	100		77.4	3	1	2.5	1.5	5,540	6,910	827
SR 60UU	120	3	60	+30	85	-22	100		77.4	3	1	2.5	2	5,980	8,230	1,240
SR 80UU	114	3	80	+58/+36	110	0/-25	100		77	3	1.5	2.5	2	7,840	12,200	2,050
SR100UU	114	3	100		130		100	77	3	1.5	2.5	2	8,430	14,700	2,440	

1N≐0.102kgf

SR-B TYPE

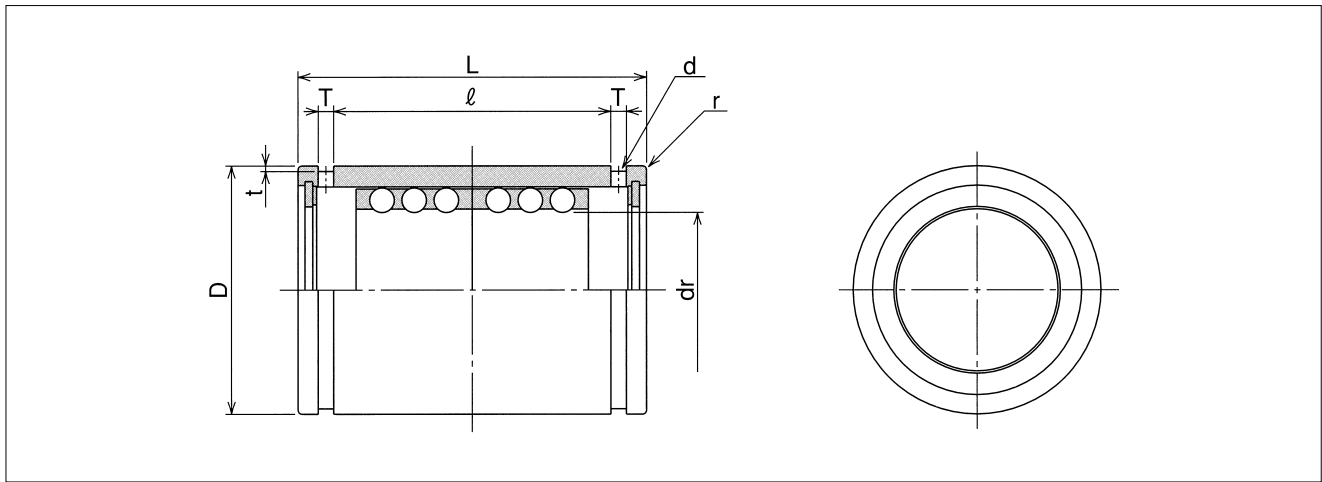
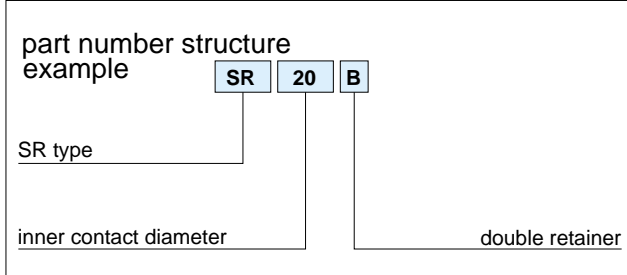

part number	maximum stroke mm	number of rows	major dimensions											basic load rating		mass g
			dr		D		L		\varnothing	T	t	d	r	dynamic C N	static Co N	
			mm	tolerance μm	mm	tolerance μm	mm	tolerance mm								
SR 8B	8	6	8	+22	15	0/-11	24	-0.2	17.1	1.5	0.5	1.2	0.5	549	490	16.8
SR 10B	8	6	10	+13	19	0	30		22.7	1.5	0.5	1.2	0.5	1,030	931	31.2
SR 12B	8	6	12	+27	23	-13	32		24.5	1.5	0.5	1.2	0.5	1,720	1,630	46
SR 16B	16	6	16	+16	28	-13	37		29.1	1.5	0.7	1.3	0.5	1,910	1,980	75
SR 20B	20	6	20	+33	32	0	45	-0.3	35.8	2	0.7	1.5	0.5	2,060	2,320	106
SR 25B	20	6	25		37	-16	45		35.8	2	0.7	1.6	1	2,170	2,670	125
SR 30B	44	6	30	+20	45	-16	65		53.5	2.5	1	2	1	4,800	6,270	220
SR 35B	54	6	35	+41	52	0	70		58.5	2.5	1	2	1.5	5,050	7,060	346
SR 40B	66	6	40		60	-19	80	68.3	2.5	1	2	1.5	6,710	9,560	540	
SR 50B	88	6	50	+25	72	-19	100	86.4	3	1	2.5	1.5	8,970	13,800	862	
SR 60B	88	6	60	+49	85	0	100	86.4	3	1	2.5	2	9,700	16,500	1,290	
SR 80B	76	6	80		+30	110	-22	100	86	3	1.5	2.5	2	12,700	24,300	2,110
SR100B	76	6	100	+58/+36	130	0/-25	100	-0.4	86	3	1.5	2.5	2	13,700	29,400	2,520

1N≐0.102kgf

SR-BUU TYPE

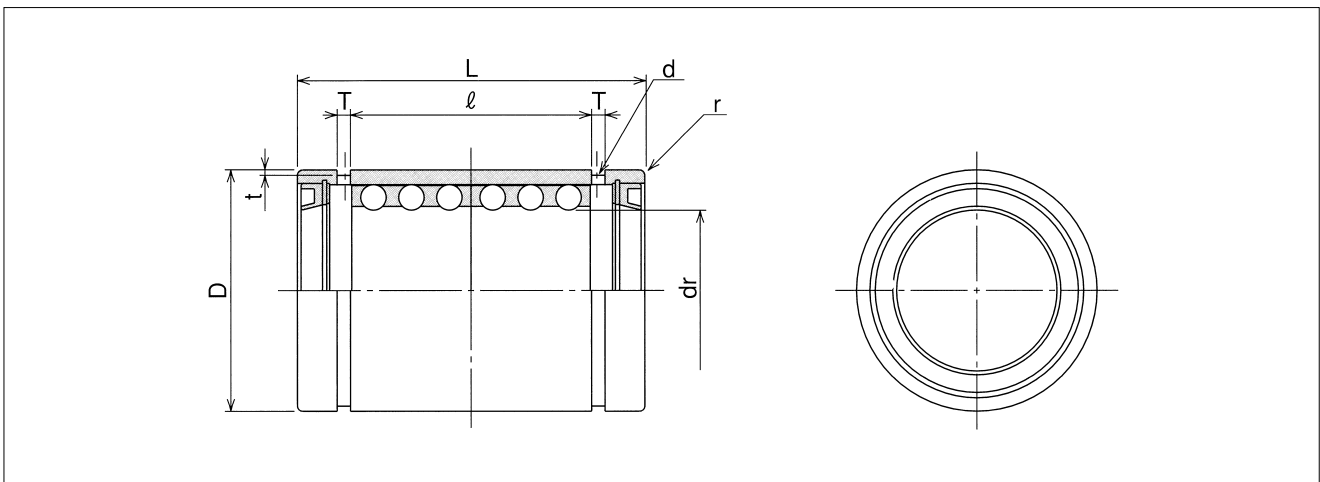
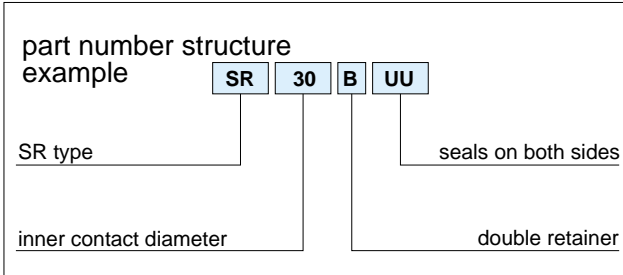

part number	maximum stroke mm	number of rows	major dimensions											basic load rating		mass g
			dr		D		L		ℓ	T	t	d	r	dynamic C N	static Co N	
			mm	tolerance μm	mm	tolerance μm	mm	tolerance mm								
SR 30BUU	27	6	30	+33/+20	45	0/-16	65	0 -0.3	45.1	2.5	1	2	1	4,800	6,270	220
SR 35BUU	37	6	35	+41	52	0	70		50.1	2.5	1	2	1.5	5,050	7,060	346
SR 40BUU	49	6	40		60	-19	80		59.9	2.5	1	2	1.5	6,710	9,560	540
SR 50BUU	70	6	50	+25	72	0	100		77.4	3	1	2.5	1.5	8,970	13,800	862
SR 60BUU	70	6	60	+49	85		100		77.4	3	1	2.5	2	9,700	16,500	1,290
SR 80BUU	58	6	80	+30	110	-22	100	0	77	3	1.5	2.5	2	12,700	24,300	2,110
SR100BUU	58	6	100	+58/+36	130	0/-25	100	-0.4	77	3	1.5	2.5	2	13,700	29,400	2,520

1N \approx 0.102kgf