

TWA TYPE

– Block Type –

(Inch Series)

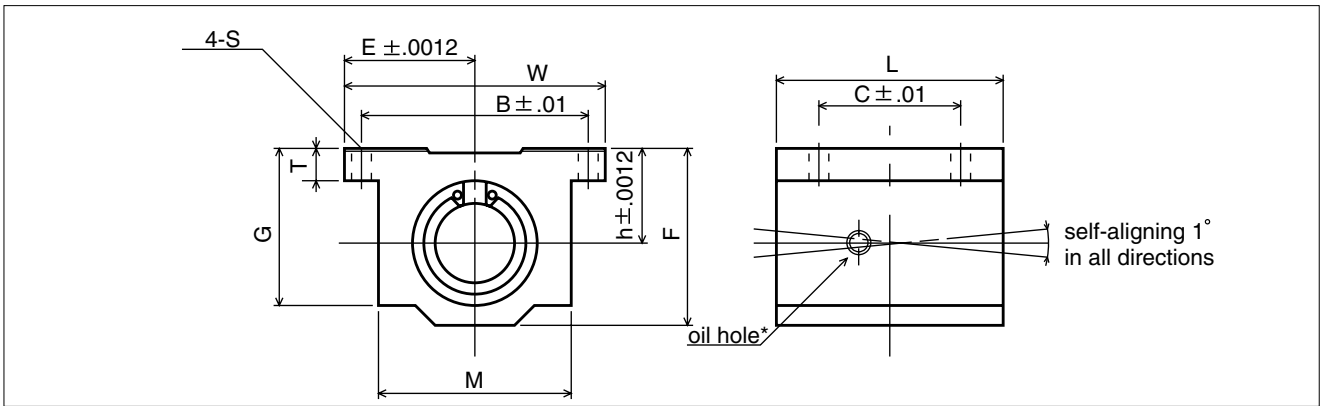
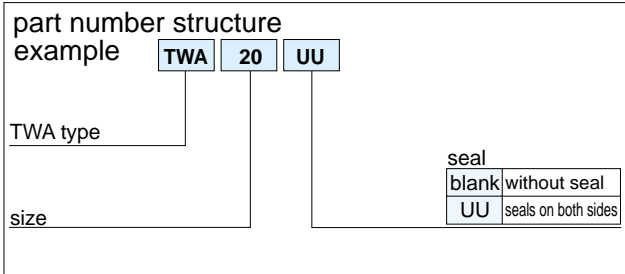
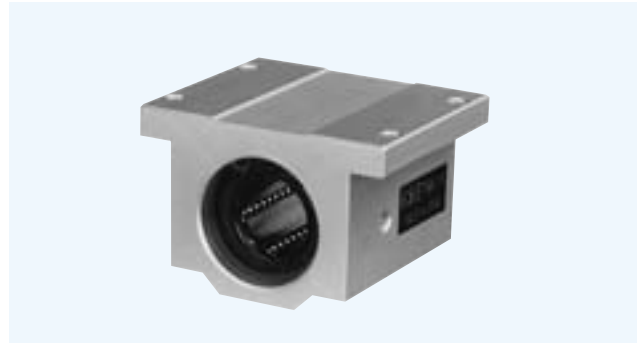

part number	nom. shaft dia. inch	major dimensions								mounting dimensions			basic load rating		mass lbs.
		h inch	E inch	W inch	L inch	F inch	T inch	G inch	M inch	B inch	C inch	S inch	C lbs.	Co lbs.	
TWA 4UU	1/4	.4370	.8125	1.625	1.188	.813	.188	.750	1.000	1.312	.750	.156	60	80	.090
TWA 6UU	3/8	.5000	.8750	1.750	1.313	.938	.188	.875	1.125	1.437	.875	.156	95	120	.120
TWA 8UU	1/2	.6870	1.0000	2.000	1.688	1.250	.250	1.125	1.375	1.688	1.000	.156	230	290	.248
TWA 10UU	5/8	.8750	1.2500	2.500	1.938	1.625	.281	1.437	1.750	2.125	1.125	.188	400	500	.465
TWA 12UU	3/4	.9370	1.3750	2.750	2.063	1.750	.313	1.563	1.875	2.375	1.250	.188	470	590	.553
TWA 16UU	1	1.1870	1.6250	3.250	2.813	2.188	.375	1.938	2.375	2.875	1.750	.219	850	1060	1.200
TWA 20UU	1-1/4	1.5000	2.0000	4.000	3.625	2.813	.438	2.500	3.000	3.500	2.000	.219	1230	1530	2.380
TWA 24UU	1-1/2	1.7500	2.3750	4.750	4.000	3.250	.500	2.875	3.500	4.125	2.500	.281	1480	1850	3.460
TWA 32UU	2	2.1250	3.0000	6.000	5.000	4.063	.625	3.625	4.500	5.250	3.250	.406	2430	3040	6.830

* Provided with push-in oil fitting for 1/4" to 1/2" sizes. Sizes from 5/8" to 2" offer a 1/4-28 tapped hole with a plug for adding a fitting if desired.

1inch = 25.4mm
1lbs ≈ 0.454kg
1lbs ≈ 4.448N

TWA-W TYPE

– Double-Wide Block Type –

(Inch Series)

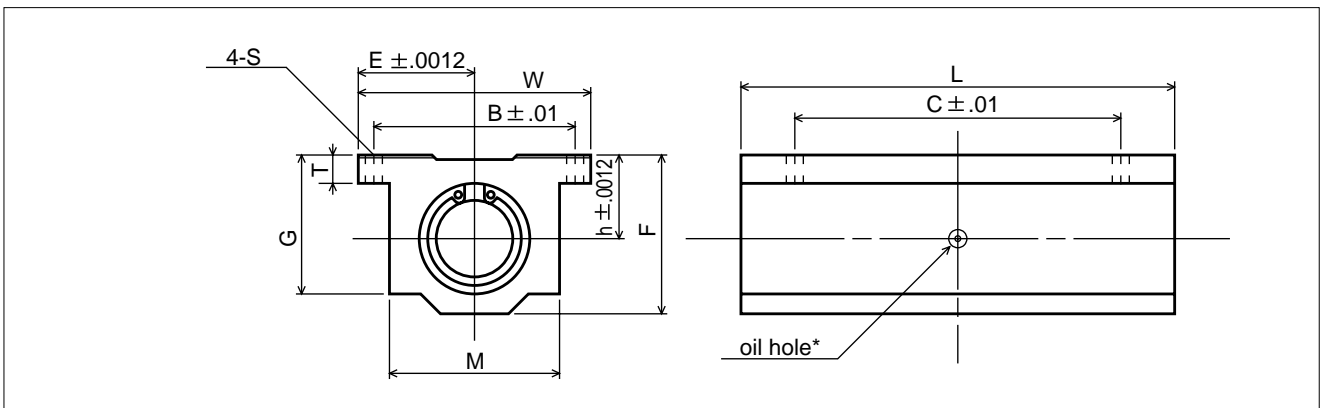
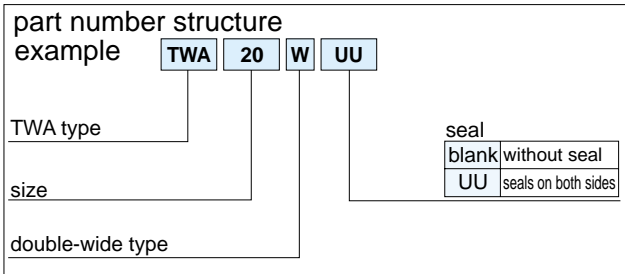

part number	nom. shaft dia.	major dimensions								mounting dimensions			basic load rating		mass
		h	E	W	L	F	T	G	M	B	C	S	C	Co	
		inch	inch	inch	inch	inch	inch	inch	inch	inch	inch	inch	lbs.	lbs.	
TWA 4WUU	1/4	.4370	.8125	1.625	2.500	.813	.188	.750	1.000	1.312	2.000	.156	96	160	.190
TWA 6WUU	3/8	.5000	.8750	1.750	2.750	.938	.188	.875	1.125	1.437	2.250	.156	150	240	.250
TWA 8WUU	1/2	.6870	1.0000	2.000	3.500	1.250	.250	1.125	1.375	1.688	2.500	.156	370	580	.510
TWA 10WUU	5/8	.8750	1.2500	2.500	4.000	1.625	.281	1.437	1.750	2.125	3.000	.188	640	1000	1.000
TWA 12WUU	3/4	.9370	1.3750	2.750	4.500	1.750	.313	1.563	1.875	2.375	3.500	.188	750	1180	1.200
TWA 16WUU	1	1.1870	1.6250	3.250	6.000	2.188	.375	1.938	2.375	2.875	4.500	.219	1360	2120	2.400
TWA 20WUU	1-1/4	1.5000	2.0000	4.000	7.500	2.813	.438	2.500	3.000	3.500	5.500	.219	1970	3060	5.000
TWA 24WUU	1-1/2	1.7500	2.3750	4.750	9.000	3.250	.500	2.875	3.500	4.125	6.500	.281	2370	3700	7.800

* Provided with push-in oil fitting for 1/4" to 1/2" sizes. Sizes from 5/8" to 2" offer a 1/4-28 tapped hole with a plug for adding a fitting if desired.

1inch = 25.4mm
 1lbs ≈ 0.454kg
 1lbs ≈ 4.448N

TWJ TYPE

— Clearance Adjustable Block Type —
(Inch Series)

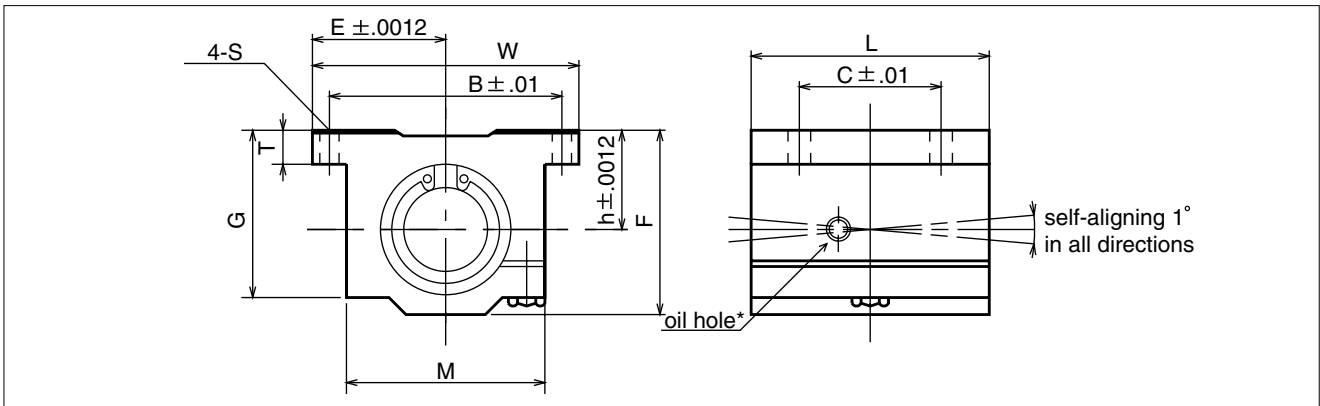
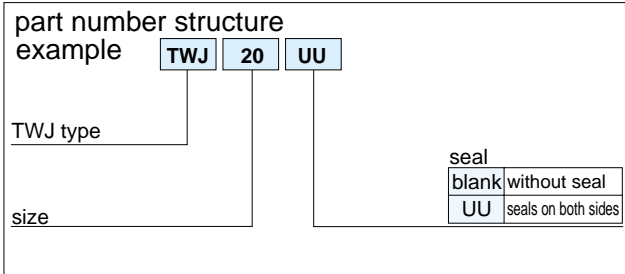
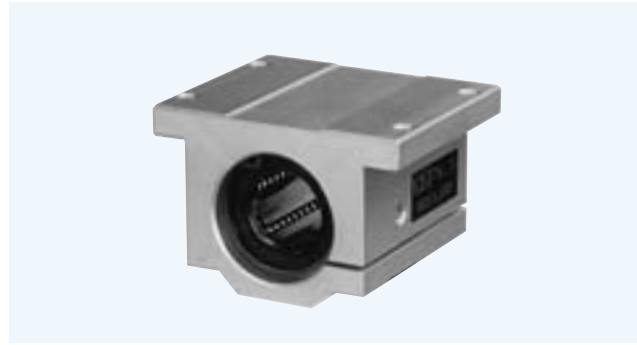

part number	nom. shaft dia. inch	major dimensions								mounting dimensions			basic load rating		mass lbs.
		h inch	E inch	W inch	L inch	F inch	T inch	G inch	M inch	B inch	C inch	S inch	C lbs.	Co lbs.	
TWJ 4UU	1/4	.4370	.8125	1.625	1.188	.813	.188	.750	1.000	1.312	.750	.156	60	80	.090
TWJ 6UU	3/8	.5000	.8750	1.750	1.313	.938	.188	.875	1.125	1.437	.875	.156	95	120	.120
TWJ 8UU	1/2	.6870	1.0000	2.000	1.688	1.250	.250	1.125	1.375	1.688	1.000	.156	230	290	.248
TWJ 10UU	5/8	.8750	1.2500	2.500	1.938	1.625	.281	1.437	1.750	2.125	1.125	.188	400	500	.465
TWJ 12UU	3/4	.9370	1.3750	2.750	2.063	1.750	.313	1.563	1.875	2.375	1.250	.188	470	590	.553
TWJ 16UU	1	1.1870	1.6250	3.250	2.813	2.188	.375	1.938	2.375	2.875	1.750	.219	850	1060	1.200
TWJ 20UU	1-1/4	1.5000	2.0000	4.000	3.625	2.813	.438	2.500	3.000	3.500	2.000	.219	1230	1530	2.380
TWJ 24UU	1-1/2	1.7500	2.3750	4.750	4.000	3.250	.500	2.875	3.500	4.125	2.500	.281	1480	1850	3.460
TWJ 32UU	2	2.1250	3.0000	6.000	5.000	4.063	.625	3.625	4.500	5.250	3.250	.406	2430	3040	6.830

* Provided with push-in oil fitting for 1/4" to 1/2" size. Sizes from 5/8" to 2" offer a 1/4-28 tapped hole with a plug for adding a fitting if desired.

1inch = 25.4mm
1lbs ≈ 0.454kg
1lbs ≈ 4.448N

TWJ-W TYPE

— Clearance Adjustable Double-Wide Block Type —

(Inch Series)

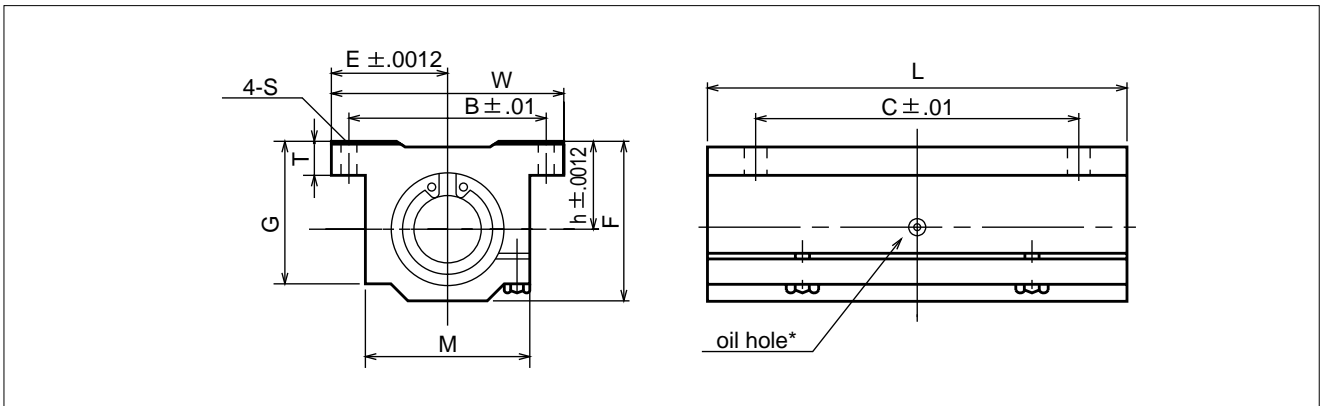
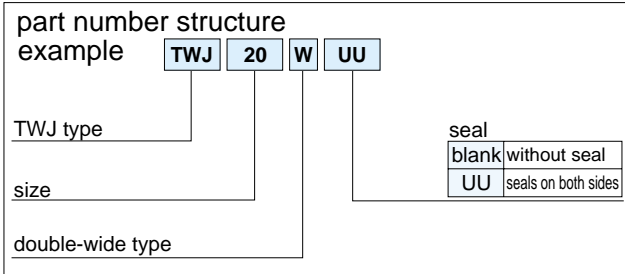
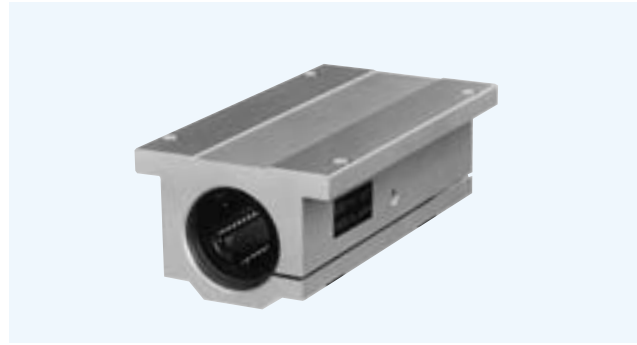

part number	nom. shaft dia. inch	major dimensions								mounting dimensions			basic load rating		mass lbs.
		h	E	W	L	F	T	G	M	B	C	S	C	Co	
		inch	inch	inch	inch	inch	inch	inch	inch	inch	inch	inch	lbs.	lbs.	
TWJ 4WUU	1/4	.4370	.8125	1.625	2.500	.813	.188	.750	1.000	1.312	2.000	.156	96	160	.190
TWJ 6WUU	3/8	.5000	.8750	1.750	2.750	.938	.188	.875	1.125	1.437	2.250	.156	150	240	.250
TWJ 8WUU	1/2	.6870	1.0000	2.000	3.500	1.250	.250	1.125	1.375	1.688	2.500	.156	370	580	.510
TWJ 10WUU	5/8	.8750	1.2500	2.500	4.000	1.625	.281	1.437	1.750	2.125	3.000	.188	640	1000	1.000
TWJ 12WUU	3/4	.9370	1.3750	2.750	4.500	1.750	.313	1.563	1.875	2.375	3.500	.188	750	1180	1.200
TWJ 16WUU	1	1.1870	1.6250	3.250	6.000	2.188	.375	1.938	2.375	2.875	4.500	.219	1360	2120	2.400
TWJ 20WUU	1-1/4	1.5000	2.0000	4.000	7.500	2.813	.438	2.500	3.000	3.500	5.500	.219	1970	3060	5.000
TWJ 24WUU	1-1/2	1.7500	2.3750	4.750	9.000	3.250	.500	2.875	3.500	4.125	6.500	.281	2370	3700	7.800

* Provided with push-in oil fitting for 1/4" to 1/2" size. Sizes from 5/8" to 2" offer a 1/4-28 tapped hole with a plug for adding a fitting if desired.

1inch = 25.4mm
1lbs ≈ 0.454kg
1lbs ≈ 4.448N

TWD TYPE

— Open Block Type —

(Inch Series)

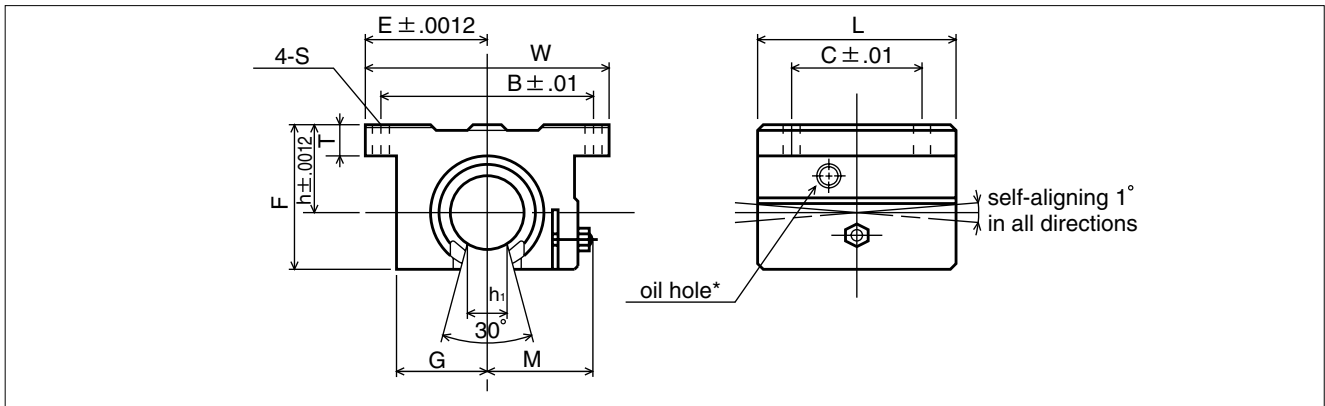
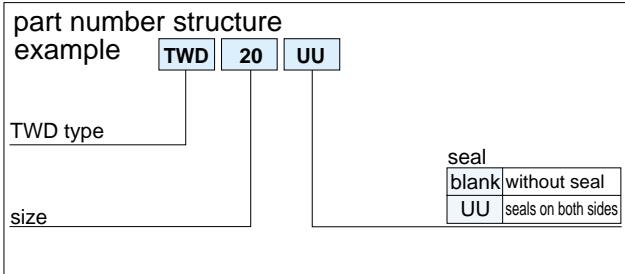

part number	nom. shaft dia. inch	major dimensions									mounting dimensions			basic load rating		mass lbs.
		h inch	E inch	W inch	L inch	F inch	T inch	G inch	M inch	h ₁ inch	B inch	C inch	S inch	C lbs.	Co lbs.	
TWD 8UU	1/2	.6870	1.000	2.000	1.500	1.100	.250	.688	.98	.260	1.688	1.000	.156	230	290	.188
TWD 10UU	5/8	.8750	1.2500	2.500	1.750	1.405	.281	.875	1.15	.319	2.125	1.125	.188	400	500	.365
TWD 12UU	3/4	.9370	1.3750	2.750	1.875	1.535	.315	.937	1.23	.386	2.375	1.250	.188	470	590	.452
TWD 16UU	1	1.1870	1.6250	3.250	2.625	1.975	.375	1.188	1.48	.512	2.875	1.750	.218	850	1060	1.010
TWD 20UU	1-1/4	1.5000	2.0000	4.000	3.375	2.485	.437	1.500	1.88	.569	3.500	2.000	.218	1230	1530	1.980
TWD 24UU	1-1/2	1.7500	2.3750	4.750	3.750	2.910	.500	1.750	2.12	.681	4.125	2.500	.281	1480	1850	2.950
TWD 32UU	2	2.1250	3.0000	6.000	4.750	3.660	.625	2.250	2.70	.933	5.250	3.250	.406	2430	3040	5.840

* Provided with push-in oil fitting for 1/4" to 1/2" size only. Sizes from 5/8" to 2" offer a 1/4-28 tapped hole with a plug for adding a fitting if desired.

1inch = 25.4mm
1lbs ≈ 0.454kg
1lbs ≈ 4.448N

TWD-W TYPE

– Double-Wide Open Block Type –
(Inch Series)

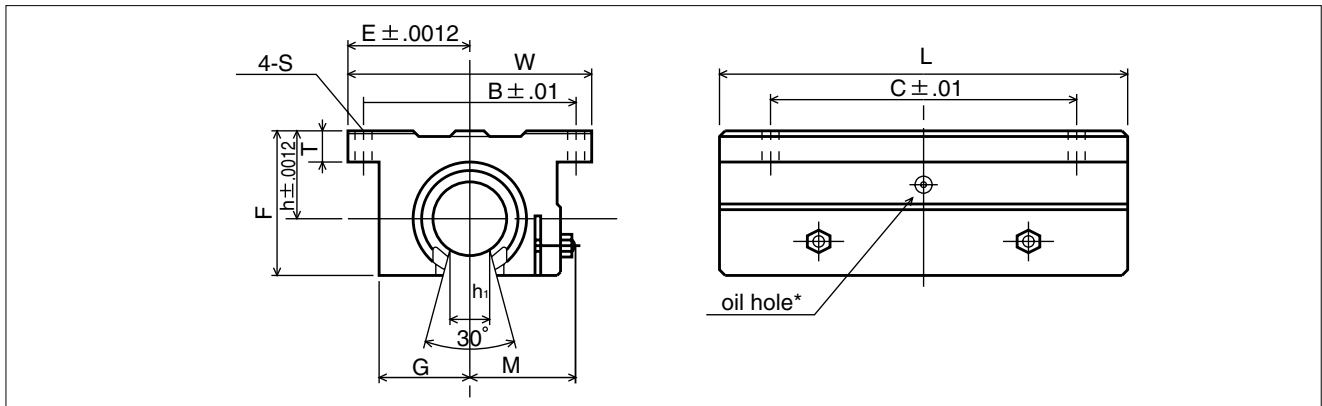
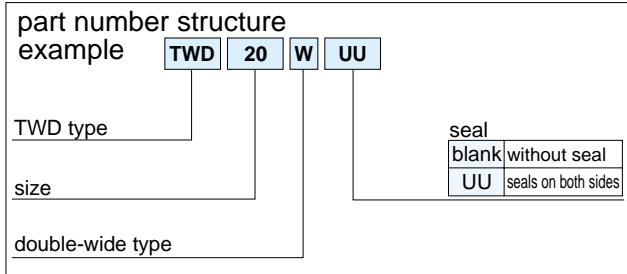
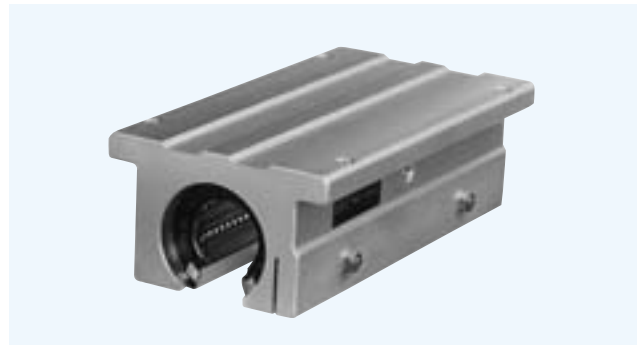

part number	nom. shaft dia. inch	major dimensions									mounting dimensions			basic load rating		mass lbs.
		h inch	E inch	W inch	L inch	F inch	T inch	G inch	M inch	h ₁ inch	B inch	C inch	S inch	C lbs.	Co lbs.	
TWD 8WUU	1/2	.6870	1.000	2.000	3.500	1.100	.250	.688	.98	.260	1.688	2.500	.156	370	580	.400
TWD 10WUU	5/8	.8750	1.2500	2.500	4.000	1.405	.281	.875	1.15	.319	2.125	3.000	.188	640	1000	.800
TWD 12WUU	3/4	.9370	1.3750	2.750	4.500	1.535	.315	.937	1.23	.386	2.375	3.500	.188	750	1180	1.000
TWD 16WUU	1	1.1870	1.6250	3.250	6.000	1.975	.375	1.188	1.48	.512	2.875	4.500	.218	1360	2120	2.000
TWD 20WUU	1-1/4	1.5000	2.0000	4.000	7.500	2.485	.437	1.500	1.88	.569	3.500	5.500	.218	1970	3060	4.200
TWD 24WUU	1-1/2	1.7500	2.3750	4.750	9.000	2.910	.500	1.750	2.12	.681	4.125	6.500	.281	2370	3700	6.700

* Provided with push-in oil fitting for 1/4" to 1/2" size. Sizes from 5/8" to 2" offer a 1/4-28 tapped hole with a plug for adding a fitting if desired.

1inch = 25.4mm
1lbs ≈ 0.454kg
1lbs ≈ 4.448N